

Remeha Gas 460 S

Gas-fired boilers

English
06/02/06

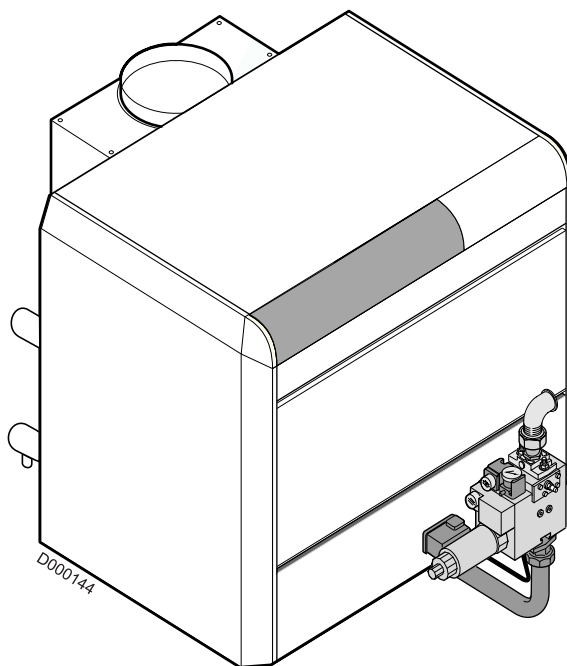

Technical
instructions

CE



300005247-001-B

remeha

Contents

Introduction	3
1 Regulations	3
2 Symbols used	3
Description	4
1 Introduction	4
2 Certifications	4
3 Main parts	5
4 Technical characteristics	7
5 Main dimensions	8
Operation	9
1 Furnace operation equipped with safety box RV 00 54 / 000 00	9
Adapting to another gas	11
2 Changing the ignition burner injector	11
3 Changing the burner injectors	12
4 Setting the injector pressure	13
5 Checking the minimum gas pressure switch setting	15
6 Attaching the label	16
Commissioning	17
1 Pressure settings and calibrated injector markings	17
2 Final checks before commissioning	18
Maintenance	19
1 Checking and cleaning the main components	19
Spare parts Gas 460 S	22
Warranty	33

Introduction

This product will be marketed in the following European Union member states:

GB - HU - ES

Directive 97/23/EC

Gas and oil boilers with a maximum operating temperature of 110°C and hot water tanks with a maximum operating pressure of 10 bar pertain to article 3.3 of the directive, and therefore, cannot be CE-marked to certify compliance with the directive 97/23 EC.



The boilers and hot water tanks are designed and manufactured in accordance with the sound engineering practice, as requested in article 3.3 of the directive 97/23/EC; it is certified by compliance with the directives 90/396/EC, 92/42/EC, 73/23 EC and 89/336/EC.

1 Regulations

 It is in any case imperative to conform to the local regulations in force.

 We would draw your attention to the danger of corrosion in boilers located in or close to premises in which the atmosphere may be polluted by chloride or fluoride compounds. For example: Hairdressing salons, industrial premises (solvents), refrigeration units. In this event, we cannot uphold the warranty.

2 Symbols used

	Caution danger	Risk of injury and damage to equipment. Attention must be paid to the warnings on safety of persons and equipment
	Specific information	Information must be kept in mind to maintain comfort
	Reference	Refer to another manual or other pages in this instruction manual

Description

1 Introduction

Gas 460 S boilers are made of cast iron:

- with atmospheric gas burners
- with 2 operating stages
- with electronic ignition via the ignition burner for hot water central heating
- with a useful output of between 119 and 380 kW

They are designed to be connected to a chimney.

The figure given after Gas 460 S indicates the number of sections which make up the boiler.

Gas 460 S boilers are delivered with a K control panel. They can be fitted with an optional RC4 and RC5 control unit (master-slave control unit options).

2 Certifications

2.1 Introduction

It is CE approved under the following number : 0085BL0187

The boilers are in compliance with the EC directives:

- Royal Decree dated 8th January 2004
- 90/396/EEC Gas Appliance Directive
- 73/23/EEC Low Voltage Directive
Reference Standard : EN 60.335.1
- 89/336/EEC Electromagnetic Compatibility Directive
Reference Standard : EN 50.081.1 ; EN 50.082.1 ; EN 55.014
- 92/42/EEC Efficiency Directive **,
Low temperature gas boiler

- Type B11 (B11_{BS} if fitted with the optional combustion products discharge control system).

France:

Performance class III boiler according to ATG B 84 recommendations.

Belgium:

The boilers comply with the specifications of the HR+ quality label.

The boilers should be fitted with a 160 VA circuit separation transformer (delivered with the documentation package).

2.2 User country

User country	ES		HU		GB
Category	II _{2H3P}		II _{2H3P}		II _{2H3P}
Gas type	G20	G31	G20	G31	G20
Distribution pressure (mbar)	20	37	25	50	20

 The boilers leave the factory operating with H natural gas.

3 Main parts

3.1 Boiler

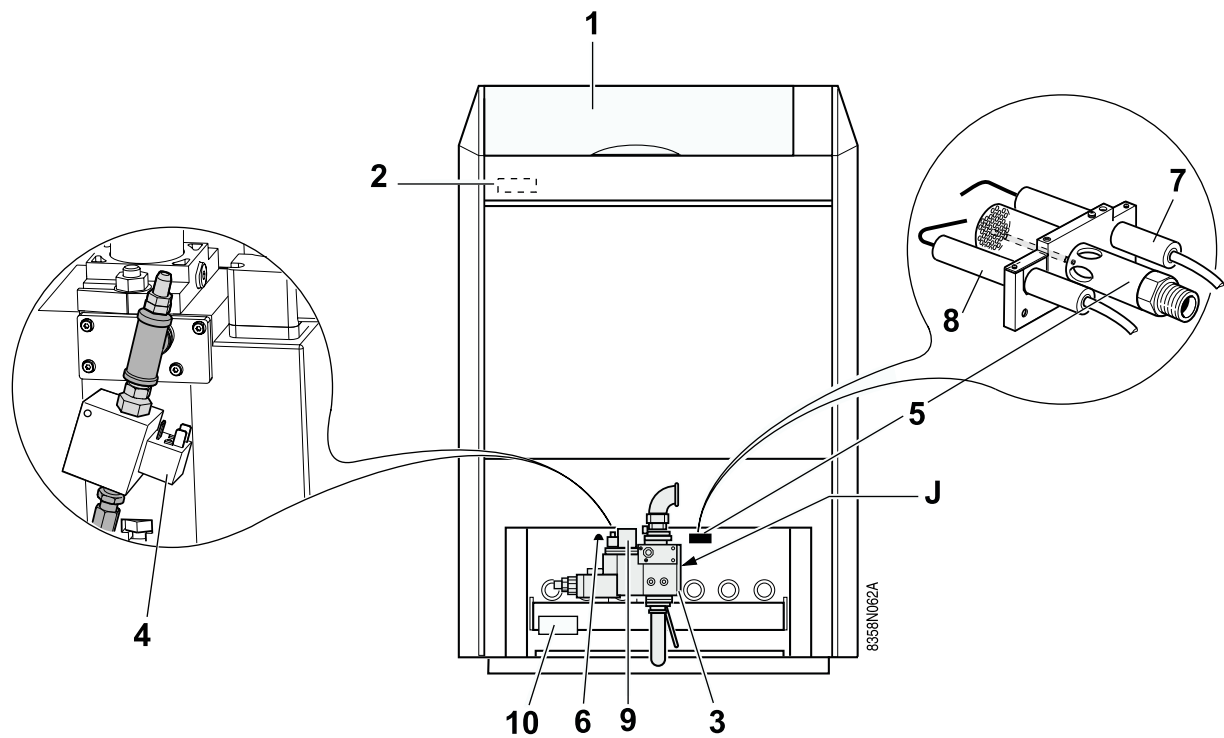

1 Control panel

2 Safety box

The safety control box is fitted to the control panel and controls the burner ignition, function and extinction sequences.

3 Multivalve gas unit:

It includes a safety valve and a 2-stage principal valve with filter and minimum gas pressure switch.

4 Ignition burner valve

5 Ignition burner

6 Flame inspection window

7 Ionisation probe: It detects flame presence on the ignition burner by flame ionisation.

8 Ignition electrode: This ensures ignition burner ignition using a high voltage spark.

9 Minimum gas pressure switch
(Minimum pressure: 12.5 mbar)

10 Ignition box

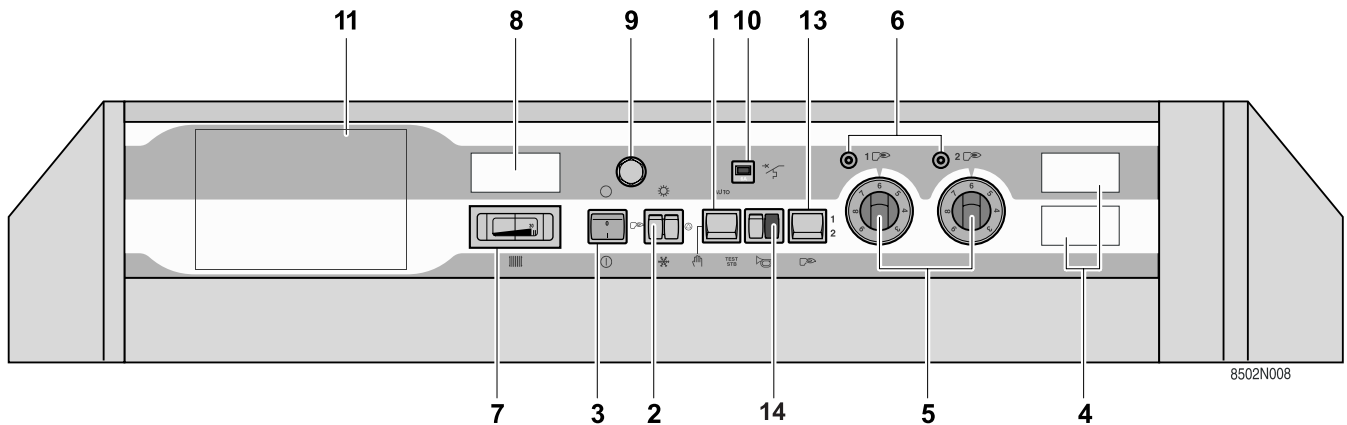

- 1 **3-position switch Auto / Manual** / TEST STB
 - The switch may be left on either position manual or automatic **AUTO**.
 - **STB TEST**: Temporary action to test the safety thermostat.
 - Press the TEST STB switch and set pump shut-off switch (2) to the "Summer" position .
- 2 **Switch Burner / Heating pump:**
 This button is used to control the burner and the heating pump.
 Both buttons are in "Winter" position: Heating and hot water production systems operate (if a hot water tank is included).
 Both buttons are in "Summer" position: The burner and the heating pump don't operate.
 If the boiler is fitted with a control unit, both buttons must be left on the Winter position.
- 3 **Main ON/OFF switch**
- 4 **Location for hour run meter for the first and second stage (optional)**
- 5 **Boiler thermostat (30 to 90 °C):**
 A factory-set stop limits the maximum temperature to 75 °C. The stop may be moved if necessary.
- 6 **Stage one or stage two indicators:**
 These only go on if the relevant thermostat or control unit require heating and if the safety contact is closed.
- 7 **Boiler thermometer**
- 8 **Location for flue gas thermometer (optional)**
- 9 **Safety thermostat with manual reset (set to 110 °C).**
- 10 **10 A Circuit-breaker:** with delayed action and manual reset.
- 11 Location for optional features or a **RC4/RC5** control unit
- 13 **Switch for selecting the number of burner stages**
- 14 **Burner alarm indicator + Reset button**

4 Technical characteristics

The boilers can operate on natural gases type H/L.

Boiler	Gas 460 S /		8	10	12	14	16	18	20
Useful efficiency	1st stage	kW	83-98	107-126	131-154	155-182	179-210	202-238	226-266
	2nd stage	kW	119-140	153-180	187-220	221-260	255-300	289-340	323-380
Power input	1st stage	kW	93.1-108.9	119.4-139.7	145.6-170.4	171.9-201.1	197.9-231.5	224-262.1	250.1-292.6
	2nd stage	kW	131.1-153	168.2-196.3	205.2-239.4	242.2-282.6	278.8-325.4		315.7-368.4
Number of sections		Part	8	10	12	14	16	18	20
Mass flue gas flow rate ⁽¹⁾		kg per sec	0.097	0.127	0.144	0.177	0.191	0.203	0.258
Flue gas temperature Tf Boiler temperature 80°C		°C	125	123	130	126	133	140	126
CO ₂	1st stage	%	3.9-4.9	3.8-4.8	4.3-5.3	4.0-5.0	4.5-5.5	5.0-6.0	4.0-5.0
	2nd stage		5.4-6.4	5.3-6.3	5.8-6.8	5.5-6.5	6.0-7.0	6.5-7.5	5.5-6.5
Ionisation current		µA	1.0						
Required depressurisation at the nozzle		daPa	0.7						
Minimum outlet temperature		°C	40						
Maximum outlet temperature		°C	90						
Maximum operating pressure		bar	6						
Electrical connection		V/Hz	230/50						
Electrical output		W	108 / 114 maximum						
Gas connection	20 mbar	inch	1"	1"	1"	1"1/4	1"1/4	1"1/4	1"1/2
Heating connection		inch	2"						
Internal diameter flue gas nozzle		mm	250	300	300	350	350	350	400
Water resistance ⁽¹⁾	Δ T = 10K	mbar	80	133	198	277	369	484	592
	Δ T = 15K		36	59	88	123	164	211	263
	Δ T = 20K		20	33	50	69	92	118	148
Water capacity*		l	61	76	91	106	122	137	154
Shipping weight		kg	668	807	934	1096	1227	1364	1476

⁽¹⁾ at 2nd stage

1 mbar = 10 mmCE = 10 daPa = 100 Pa

5 Main dimensions

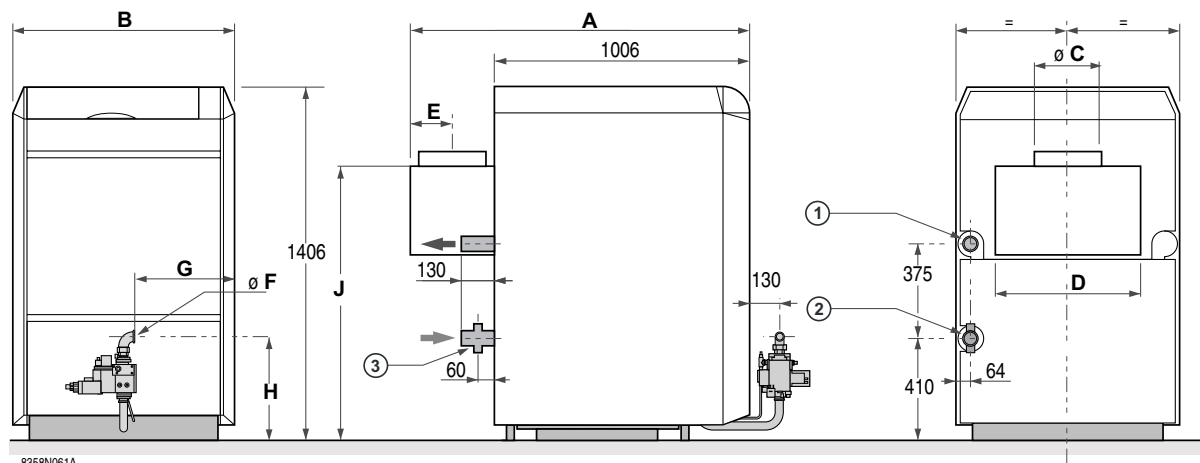

① Heating outlet R 2

③ Draining Rp 3/4

② Heating return R 2

Boiler Gas 460 S	/8	/10	/12	/14	/16	/18	/20
A (mm)	1362	1362	1362	1412	1412	1412	1462
B (mm)	970	1146	1322	1498	1674	1850	2026
Ø C (mm)	250	300	300	350	350	350	400
D (mm)	632	808	984	1160	1336	1512	1688
E (mm)	165	165	165	190	190	190	220
Ø F (mm) (20/25 mbar)	Rp1	Rp1	Rp1	Rp1 1/4	Rp 1 1/4	Rp 1 1/4	Rp 1 1/2
Ø F (mm) (300 mbar)				Rp 3/4			
G	447	535	623	704	792	880	963
H	445	445	445	454	454	454	507
J	1094	1094	1094	1194	1194	1194	1194

1 Furnace operation equipped with safety box RV 00 54 / 000 00

Operating principle

The boiler can operate at either 2nd stage or 1st stage depending on the thermal needs of the installation.

The ignition and burner surveillance sequences are ensured by the safety box.

Behaviour in normal conditions

The box closes the TCH contact when there is a requirement for heat. The safety control box runs an auto-check of around 1 second(s) by lighting the alarm warning light **VA**.

 **In the case of an offset alarm, it is necessary to use a timed relay in order to prevent an unjustified alarm signal.**

After a waiting time **tw**, the ignition transformer **TA** produces a series of sparks at the ignition electrode. After a pre-ignition period **tvz**, the ignition burner valve **VG** and the safety valve **VS** open. Formation of flame in ignition burner. The ionisation sensor **SF** shows a flame signal with a minimum ionisation current of 1 μ A and ignition is shut down. After a period of stabilisation **tstab**, the principal burner ignites at 1st stage **BR1** (or at 2nd stage if the 2nd stage thermostat **TCH2** is needed).

Behaviour in abnormal conditions

- If a flame is not detected before the safety time **ts**, the box makes 2 more ignition attempts. If, at the end of the last attempt, there is still no flame signal, the box goes into safety and the safety indicator comes on. To restart the heater, press the reset button on the safety box.
- If there is a loss of flame in normal operation, the box automatically repeats the start up sequence.

Resetting

The box is reset after going into safety by pressing the reset button. If the reset button does not work, wait at least 15 seconds before trying a second time. After activating the reset button, the warning light goes out and the safety control box restarts **after a waiting time of around 1 minute**.

Note 1: The box may be on safety on its first start up: press the reset button to release it.

Note 2: If the reset button is pressed in normal operation, the gas valves close and the box starts a new ignition sequence.

Normal operating cycle

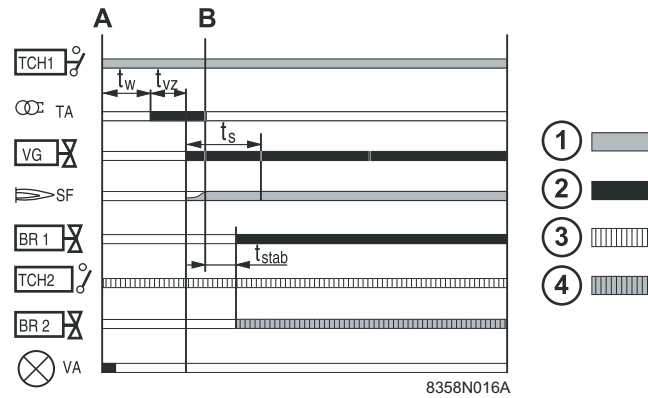

Operating cycle on safety (start up without flame signal)

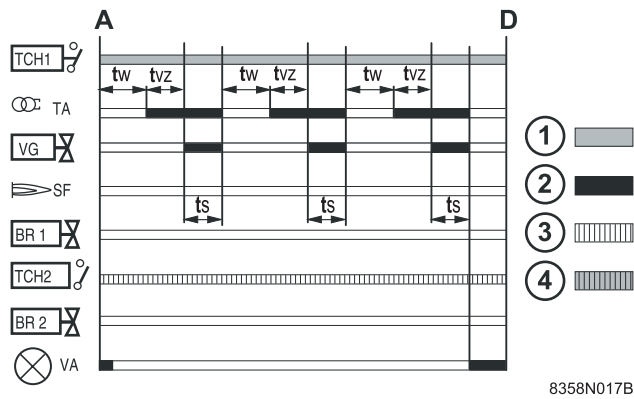

- ① Required input signals
- ② Box output signals
- ③ Thermostatic request at 2nd stage
- ④ Operation 2nd stage

- A** Start of operation
- B** Formation of flame in ignition burner
- BR1** 1st stage
- BR2** 2nd stage
- SF** Burner flame signal
- TA** Ignition transformer
- TCH1** Boiler thermostat 1 Speed
- TCH2** Boiler thermostat 2 Speed
- VA** Safety lockout warning light
- VG** Ignition burner valve + Safety valve **VS**
- ts** Safety time: maximum 10 seconds
- tstab** Flame stabilisation time: 5 seconds
- tvz** Pre-ignition time: 10 seconds
- tw** Waiting time: 0 seconds

Adapting to another gas

! These actions must be carried out by a qualified technician.

! Belgium: The operations required to switch from one gas to another must be carried out by a SERV'elite technician.

1 Changing gas

The boilers are factory-set to operate on natural gas H (G20 - 20 mbar). To convert it to natural gas L, use the gas L conversion kit (optional). Carry out the operations described below.

2 Changing the ignition burner injector

Operations to be carried out to convert from natural gas H to natural gas L and vice versa:

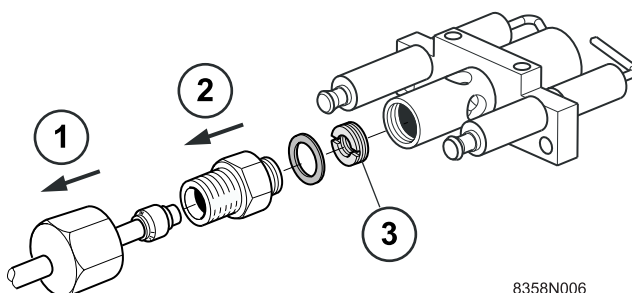

① Remove the gas supply pipe from the ignition burner (13 mm spanner).

② Remove the nozzle + seal.

③ Unscrew the nozzle using a screwdriver and screw in the new injector.

- Reassemble the parts
- Carry out a leak tightness check

	Natural gas H	Natural gas L
Nozzle marking	80	100
Nozzle diameter	0.80 mm	1.00 mm

3 Changing the burner injectors

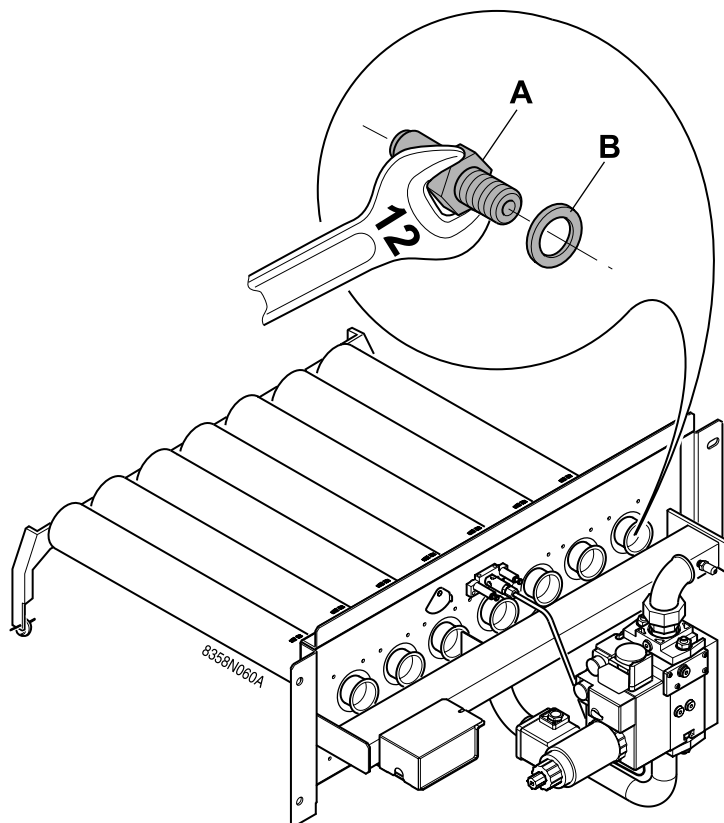

- Close the gas valve.
- Lift out the injector with a number 12 spanner assemble the new injectors with their new joint.

i First tighten the injectors by hand and carefully lock them using a spanner.

- Carry out a leak tightness check.

	Natural gas H	Natural gas L
Nozzle marking	390A	450A
Nozzle diameter	3.9 mm	4.5 mm

Setting the pressure 2nd stage

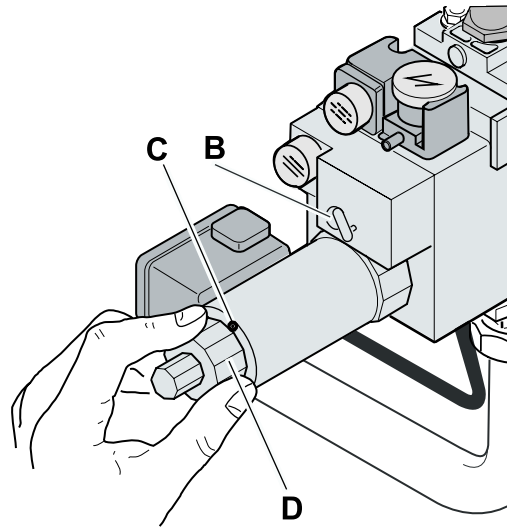

8358N008

The pressure must be set by a qualified professional.

The boiler must be commissioned after having checked the points covered in this chapter: Final checks before commissioning.

- Connect a manometer to the pressure outlet.
 - Run the boiler at 2nd stage, activating the thermostat(s).
 - Set the pressure at the injectors as follows:
 - Free the cylindrical split head screw **C** by around one turn. Fully unscrew the setting button **D** (anti-clockwise). Tighten the screw **C**.
 - Set the pressure at the injectors by turning the screw on the regulator **B**. By turning to the right, you increase and, by turning to the left, you decrease the principal flow.
- i** If you find you cannot tighten screw **B** any further before reaching the desired pressure, unscrew **B** again by a quarter turn and continue the setting by turning **D** after freeing the inhibitor screw **C**.
- On propane, the regulator **B** is fully tightened. It is not used.

Setting the pressure 1st stage

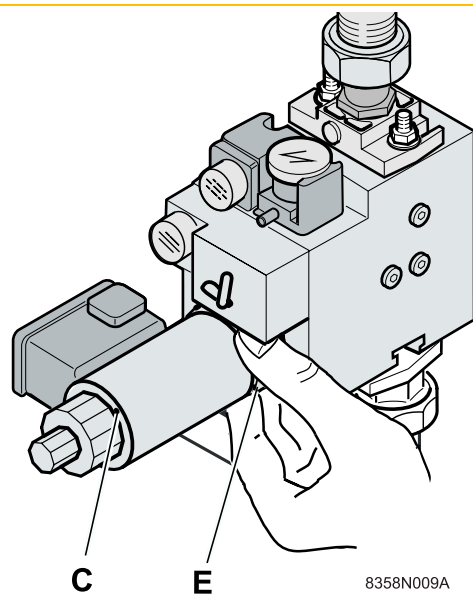

8358N009A

- Run the boiler at 1st stage by activating the burner on selector switch on the boiler control panel.
- Set the flow in such a way as to obtain pressure at the injectors (0.5 x Pressure 2nd stage):
 - Set the 1st stage flow with the ring **E**.
 - By turning to the right, you increase and, by turning to the left, you decrease the principal flow.
 - Tighten the inhibitor screw **C**.

Setting the start-up progressivity (or initial flow)

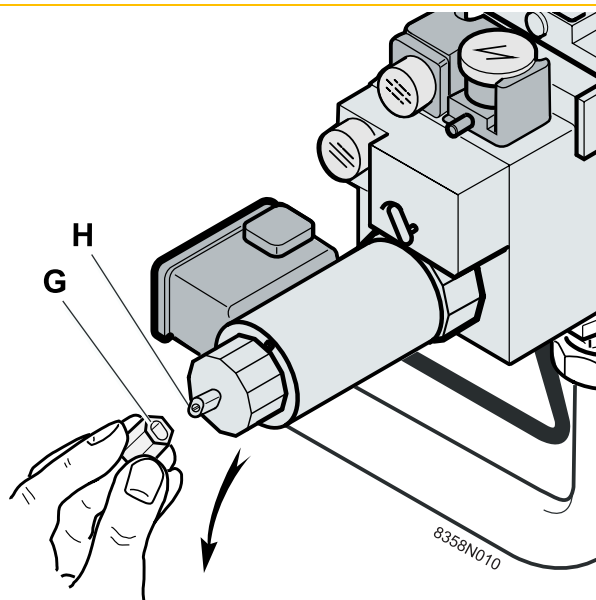

In the factory, the progressivity is set to minimum (low start-up pressure).

Depending on the installation conditions, adjust the progressivity setting in order to guarantee optimum boiler start-up.

- Unscrew the protection cap **G**. Use like a spanner to turn the setting rod **H** until you obtain the desired initial flow.
- Put the cap back in place.

5 Checking the minimum gas pressure switch setting

The minimum gas pressure switch on the safety valve is set in the factory to a value of 12.5 mbar, which corresponds to the setting for natural gas.

To operate on propane, set the start-up pressure to 20 mbar.

If there is a drop in the gas supply pressure, the minimum pressure switch shuts down the boiler.

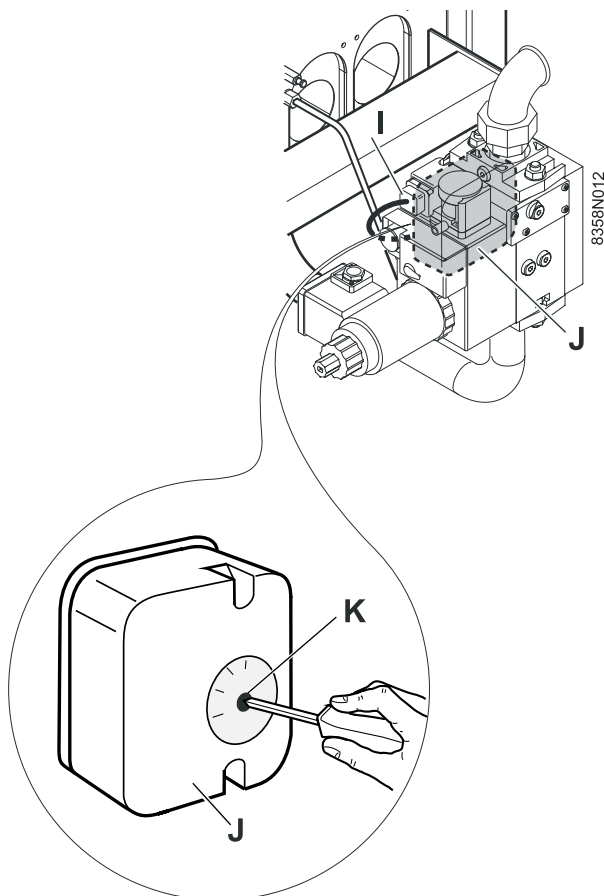

6 Attaching the label

Affix the label which indicates for which type of gas the boiler is fitted and set.

Commissioning

1 Pressure settings and calibrated injector markings

1.1 Table of pressure settings and injector markings + Flow table (15°C - 1013 mbar)

Boiler type Gas 460 S /			8	10	12	14	16	18	20
Useful efficiency									
1st stage		kW	83-98	107-126	131-154	155-182	179-210	202-238	226-266
2nd stage		kW	140	180	220	260	300	340	380
Power input									
1st stage		kW	93.1-108.9	119.4-139.7	145.6-170.4	171.9-201.1	197.9-231.5	224-262.1	250.1-292.6
2nd stage		kW	131.1-153	168.2-196.3	205.-239.4	242.2-282.6	278.8-325.4	315.7-368.4	352.4-411.3
Nozzle									
Diameter, principal burner injector Gas H		mm				3.9			
Diameter, principal burner injector Gas L		mm				4.5			
Diameter, ignition burner injector	Gas H	mm				0.8			
	Gas L	mm				1.0			
Gas flow rate									
Gas H	1st stage	m ³ /h	9.35-11.52	12.63-14.78	15.41-18.03	18.19-21.28	20.94-24.50	23.71-27.74	26.47-30.97
	2nd stage		13.88-16.19	17.80-20.77	21.71-25.33	25.63-29.91	29.51-34.43	33.40-38.98	37.29-43.52
Gas L	1st stage	m ³ /h	11.46-13.40	14.70-17.19	17.92-20.97	21.16-24.75	24.36-28.50	27.57-32.26	30.78-36.02
	2nd stage		16.14-18.83	20.70-24.16	25.25-29.46	29.81-37.78	34.32-40.05	38.85-45.34	43.38-50.62
Downstream gas pressure									
Gas H	1st stage	mmCE	Pressure 1st stage = 0.5 x 2nd stage pressure set						
	2nd stage		90-120						
Gas L	1st stage	mmCE	Pressure 1st stage = 0.5 x 2nd stage pressure set						
	2nd stage		74-100						

2 Final checks before commissioning

! The first start-up is to be performed by your installation engineer.

! Make the gas line setting before commissioning.

Check the following points before starting the heater:

Hydraulic circuit:

- ▶ Check that the installation and boiler are adequately filled with water and correctly irrigated and bled.
- ▶ Check that the hydraulic connections are leak tight.

Gas circuit:

- ▶ Check the adjustment of the gas line:
 - Connect a manometer to the pressure socket located on the manifold.
 - Check that the nozzle pressure and the start-up pressure match the pressures given in the relevant chapter: Pressure settings and calibrated injector markings.If necessary, adjust the pressure as shown in the relevant chapters: Setting the injector pressure.

Electrical connectors:

Check that the connectors under the control panel are correctly fitted:

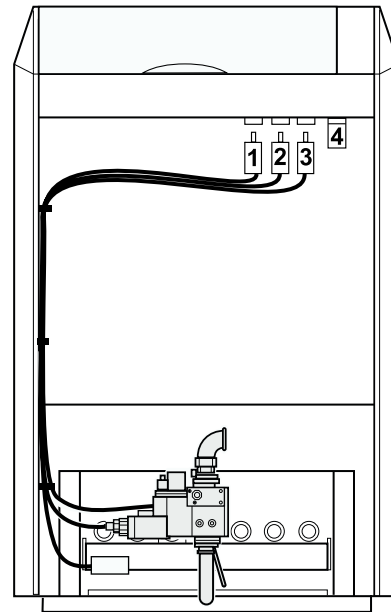

- 1 Ignition circuit
- 2 Gas pressostat
- 3 Gas valve circuit
- 4 Leak proofing system (Options RE 30)

1 Checking and cleaning the main components

1.1 Cleaning heater body

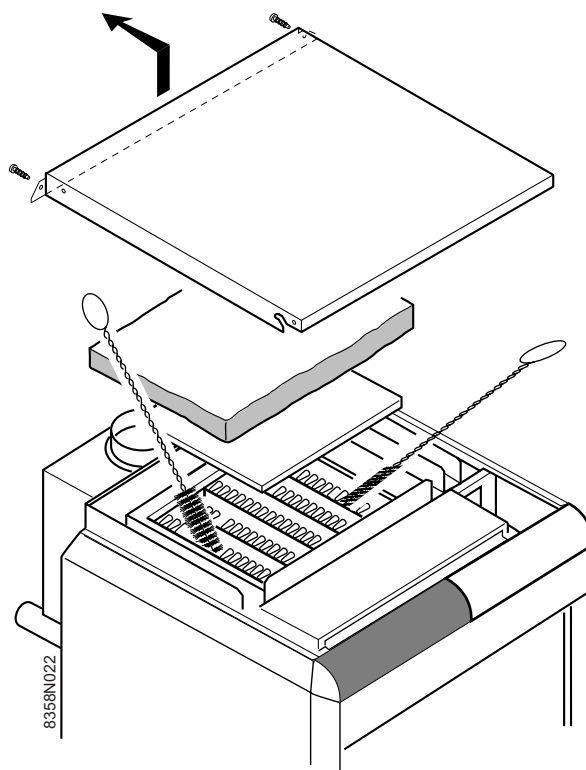

The extent of clogging on the heating body must be checked once a year.

If it is necessary to sweep the boiler, remove the burner drawer to prevent deposits and soot blocking the orifices in the gas trains.

With the burner out:

- Remove the upper casing of the boiler
- Take out the insulation
- Remove the sweeping hatch from the draught diverter
- If necessary, clean the boiler body using the special brush provided
- Clean the combustion chamber using a vacuum cleaner

1.2 Cleaning main burner and ignition burner

The main burner and the ignition burner injector with its filter must be regularly cleaned to ensure good performance. We recommend doing this at least once a year.

 **These actions must be carried out by a qualified technician.**

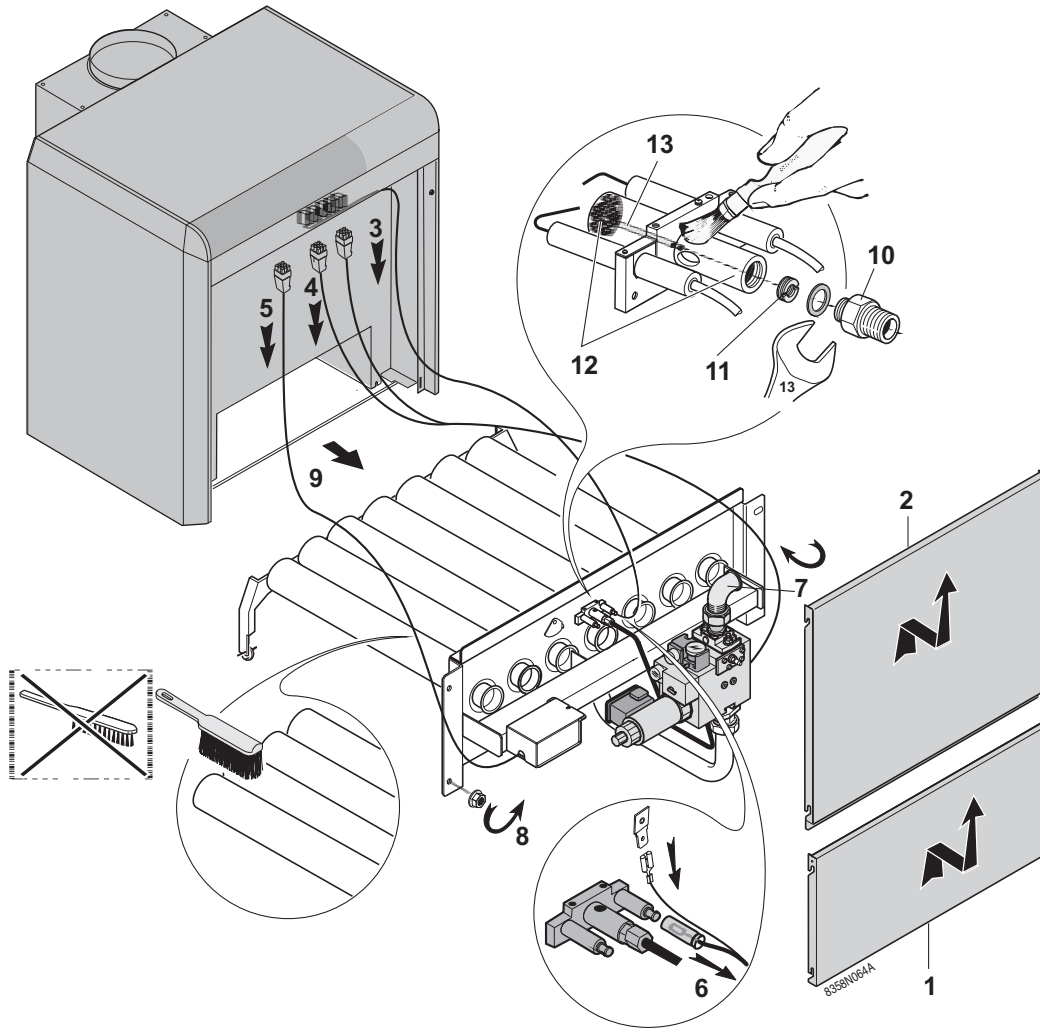

Main burner

Ignition burner

- Switch off the boiler electrical power supply
 - Cut the gas supply
- 1 Remove the lower cladding panel
 - 2 Remove the intermediate cladding panel
 - 3 Disconnect the valve connector
 - 4 Disconnect the gas pressure switch connector (and the leak proofing cyclical control system, if there is one) under the control panel
 - 5 Disconnect the ignition circuit
 - 6 Disconnect the ionisation cable and the ground conductor on the ionisation sensor side
 - 7 Unscrew the union joint on the gas inlet pipe
 - 8 Unscrew the 4 holding nuts on the burner drawer
 - 9 Take out the burner drawer
- Clean the burner trains (slits) using a soft brush, a short-handled brush or a vacuum cleaner.

- 10 Remove the gas supply pipe from the ignition burner (13 mm spanner)
- 11 Clean the injector
- 12 Clean the ignition burner
- 13 Clean the flame stabilisation pipe located inside the ignition burner

 **Do not use a metal brush.**

1.3 Painted surfaces

The painted surfaces can be cleaned with tepid or cold soapy water.
Wipe the painted surfaces with a soft cloth or a damp sponge.

Spare parts Gas 460 S

i The code number on the list next to the required piece must be stated when ordering replacement parts.

01/10/05 - 300005247-002-A

Boiler body

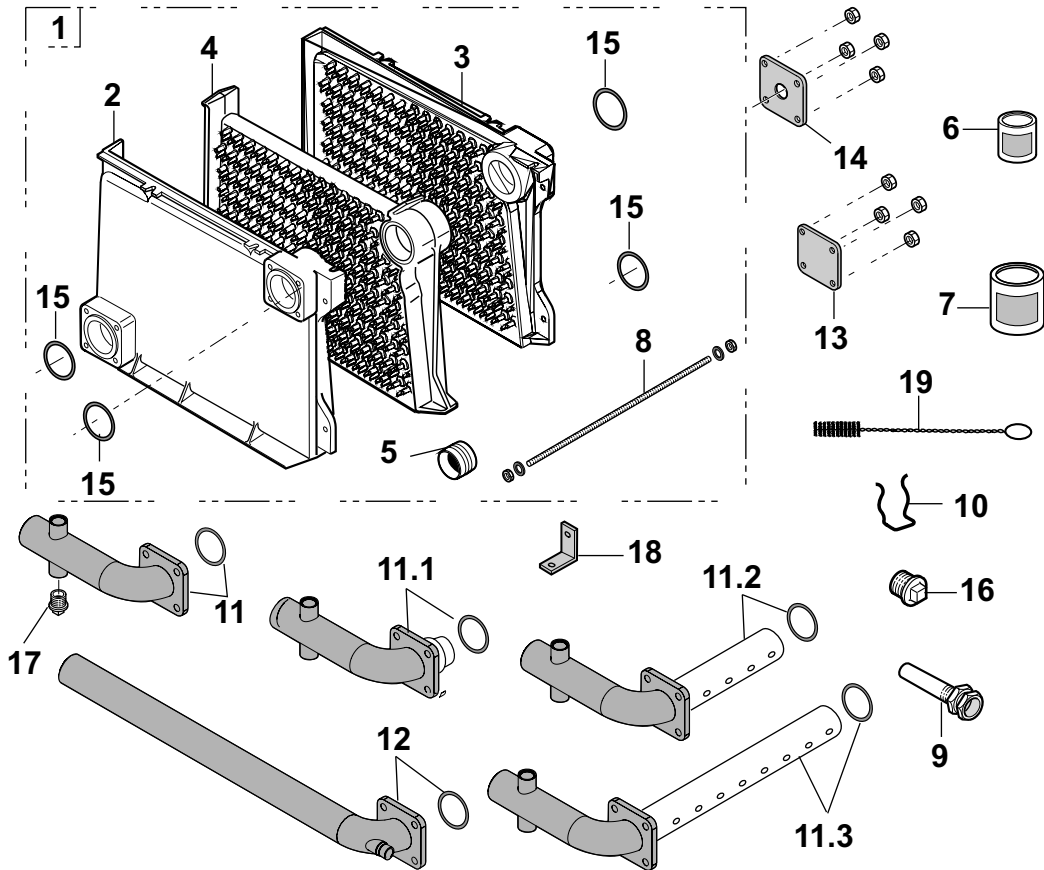

Base frame + Draught diverter

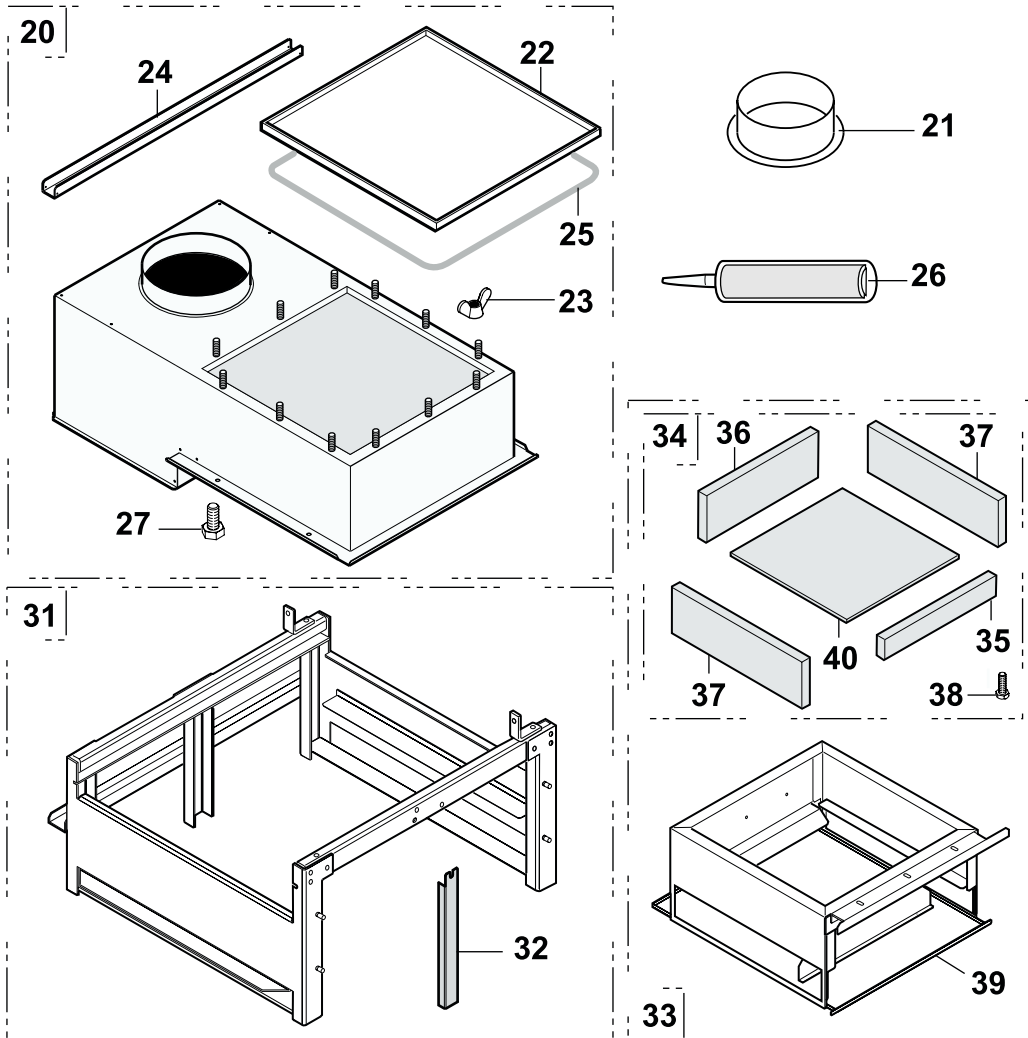

8358N098

Insulation

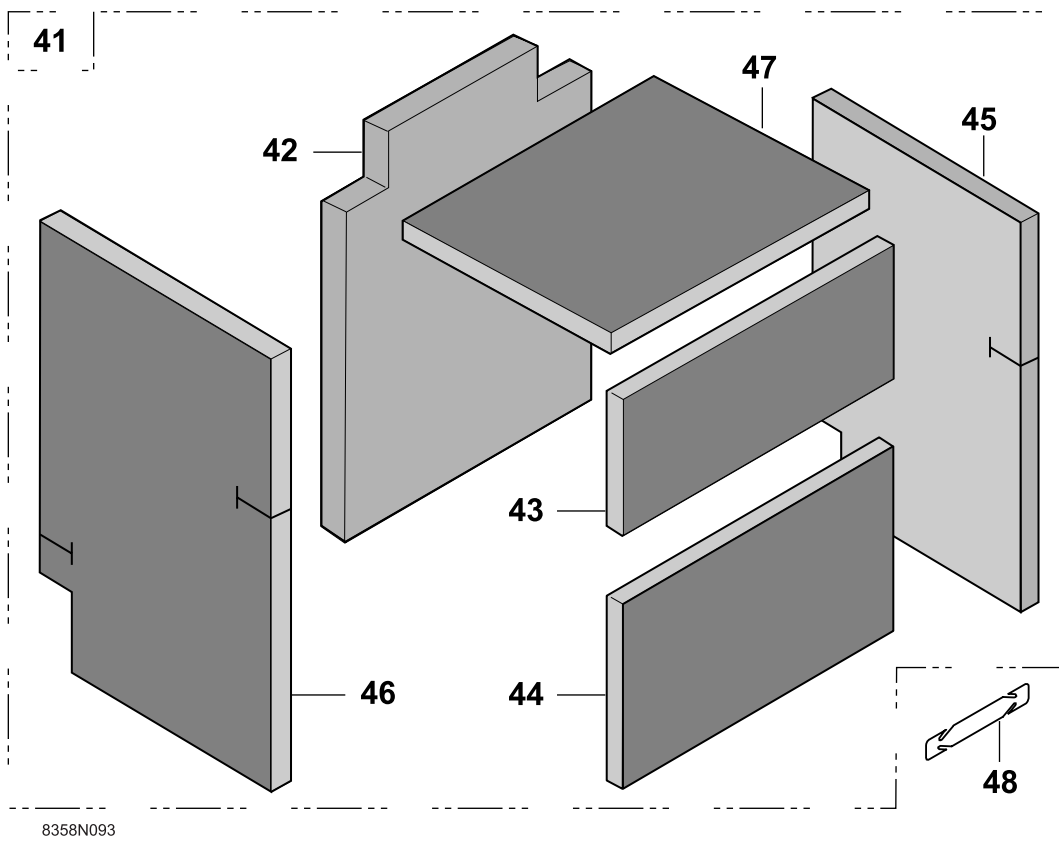

Control panel K

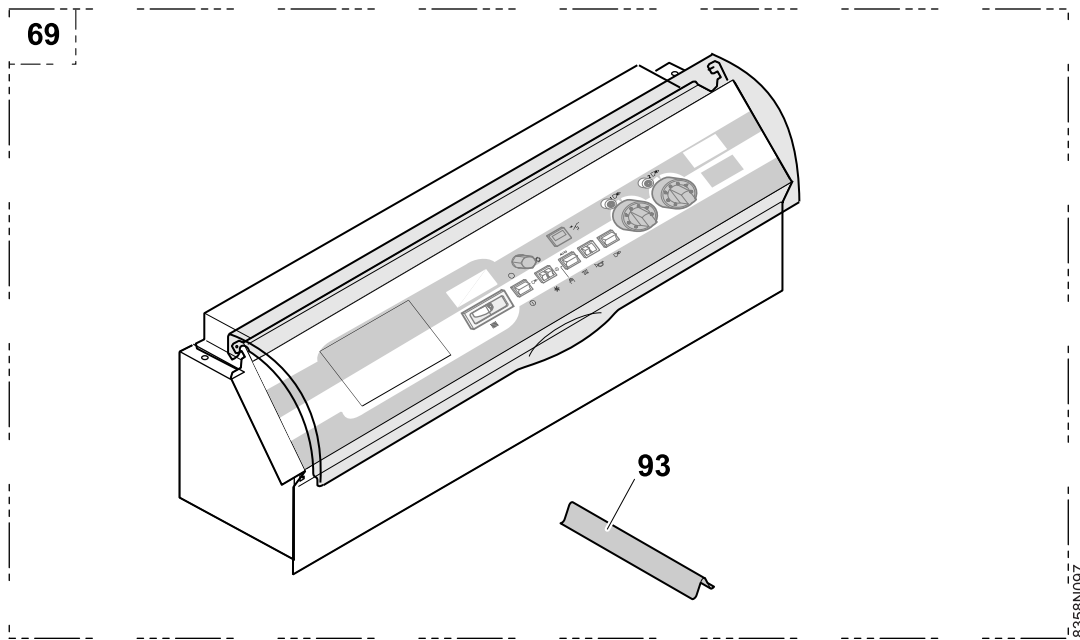

8358N097

Control panel K + Components

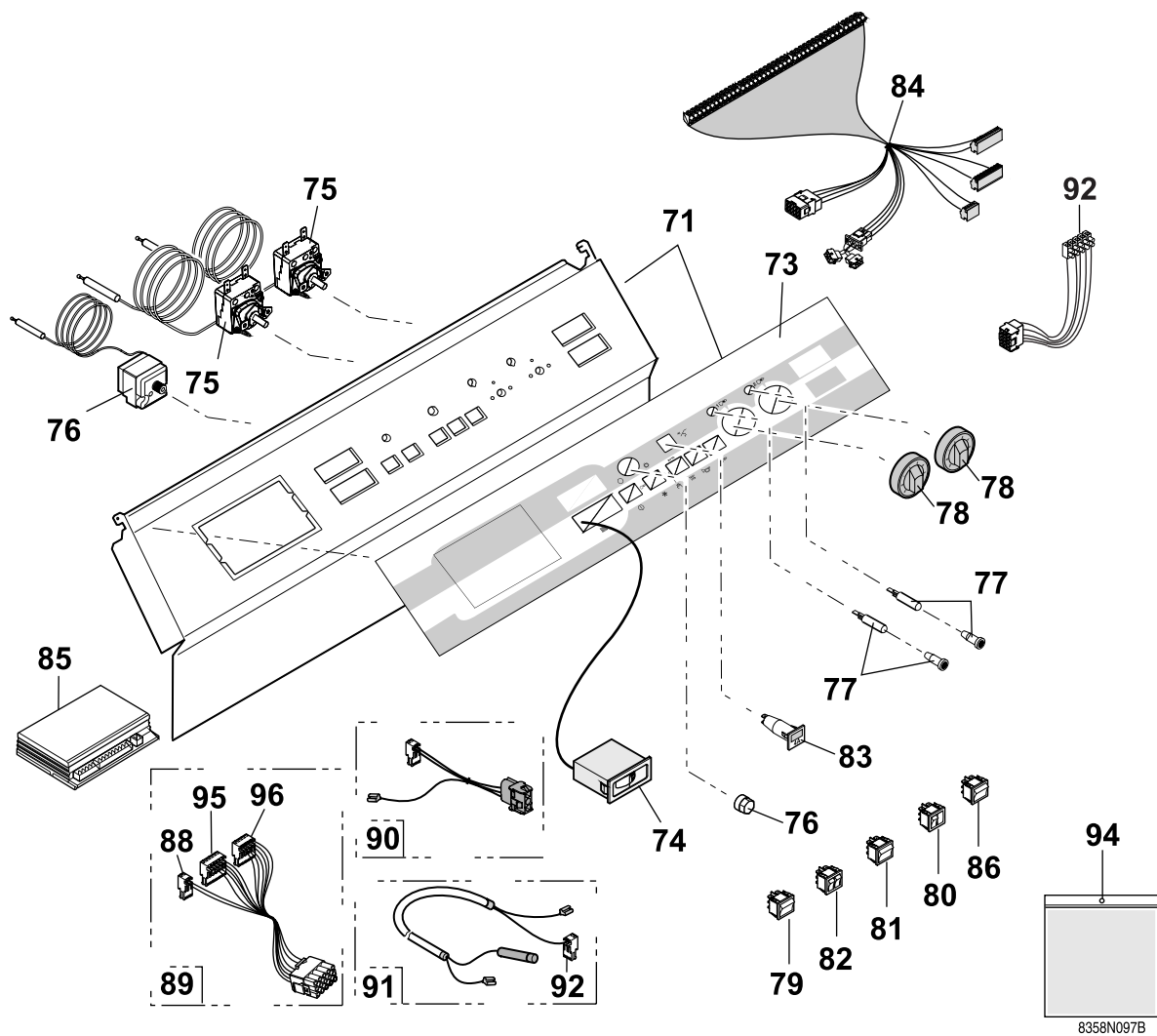

8358N097B

Metal casing for control panel K

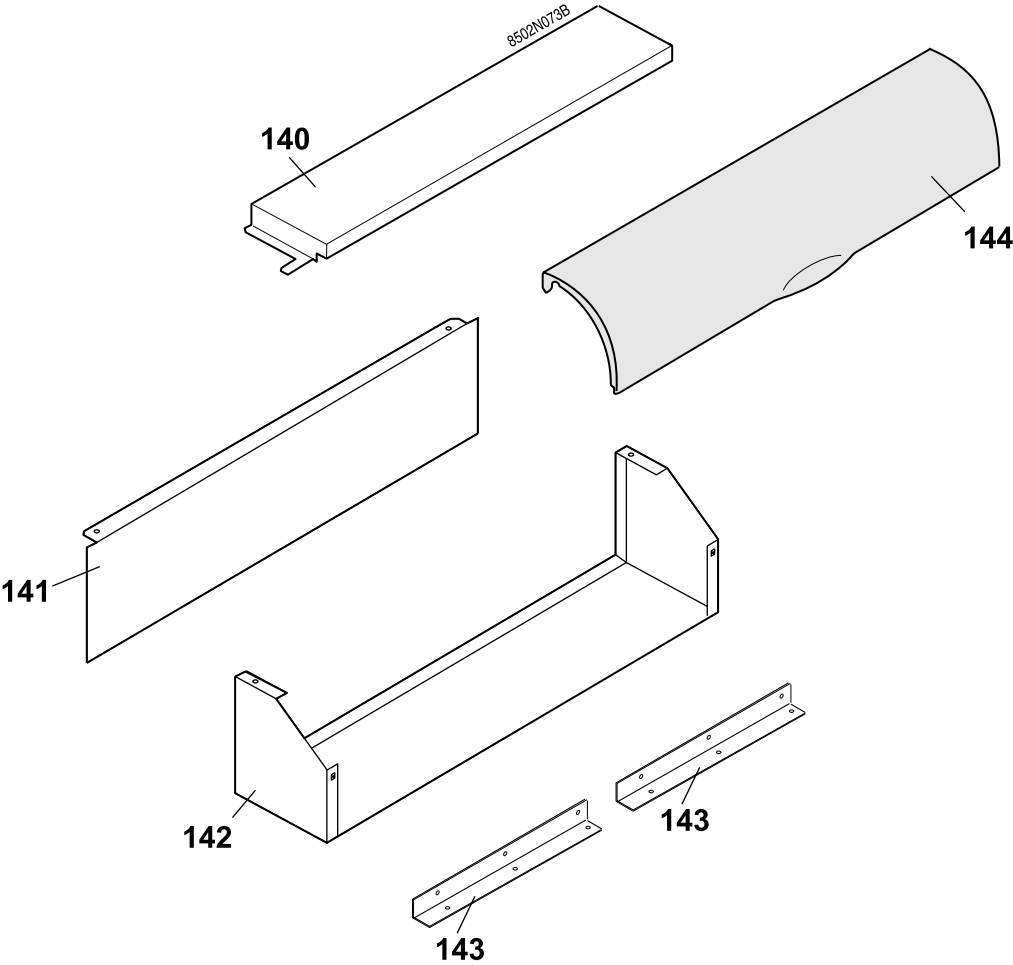

Gas line 20 mbar

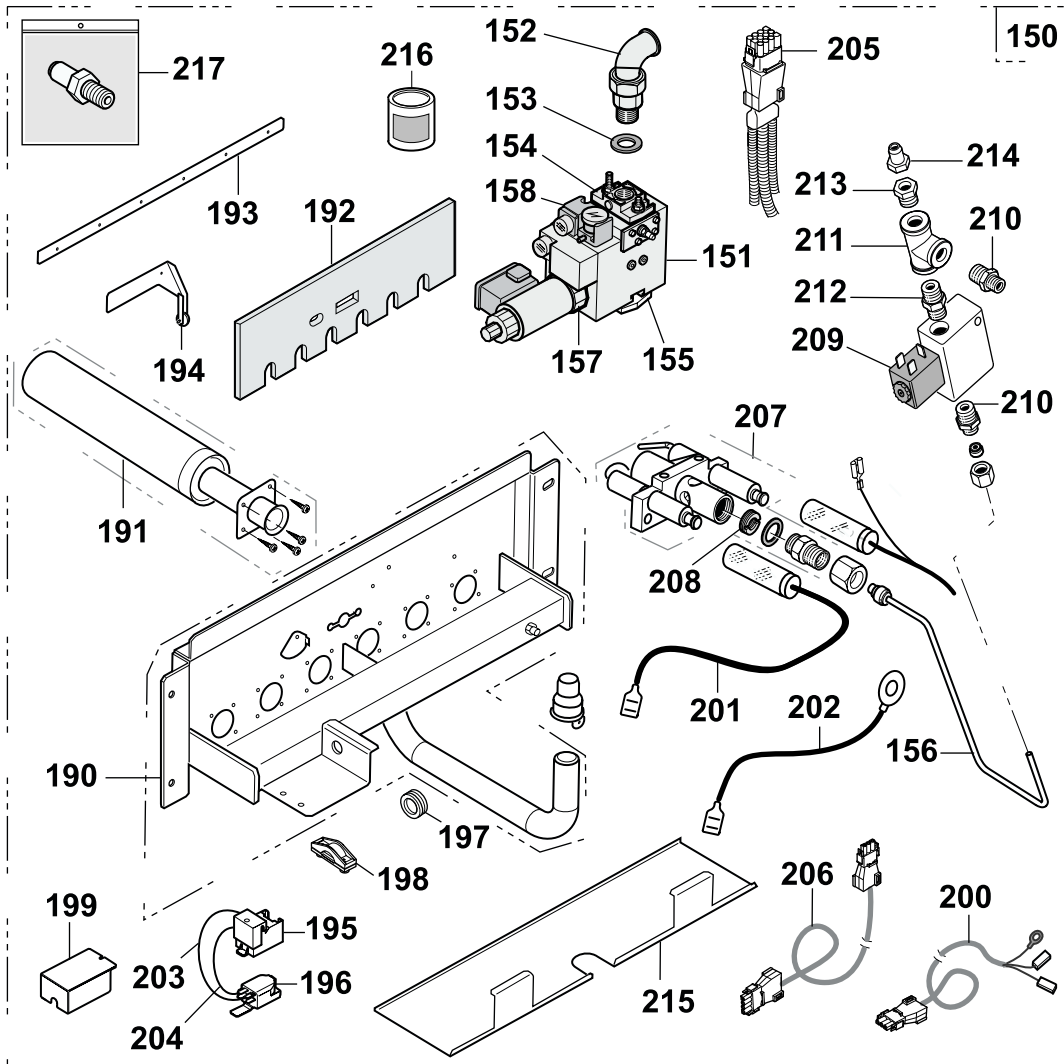

8358N100B

Circuit separation transformer

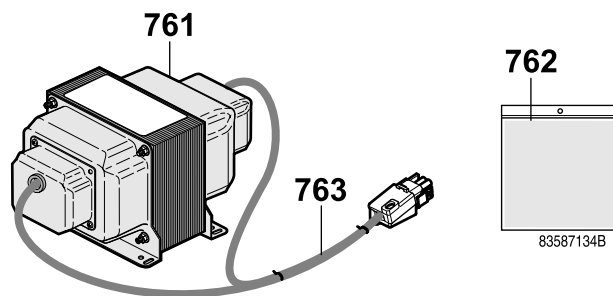

83587134B

Cladding

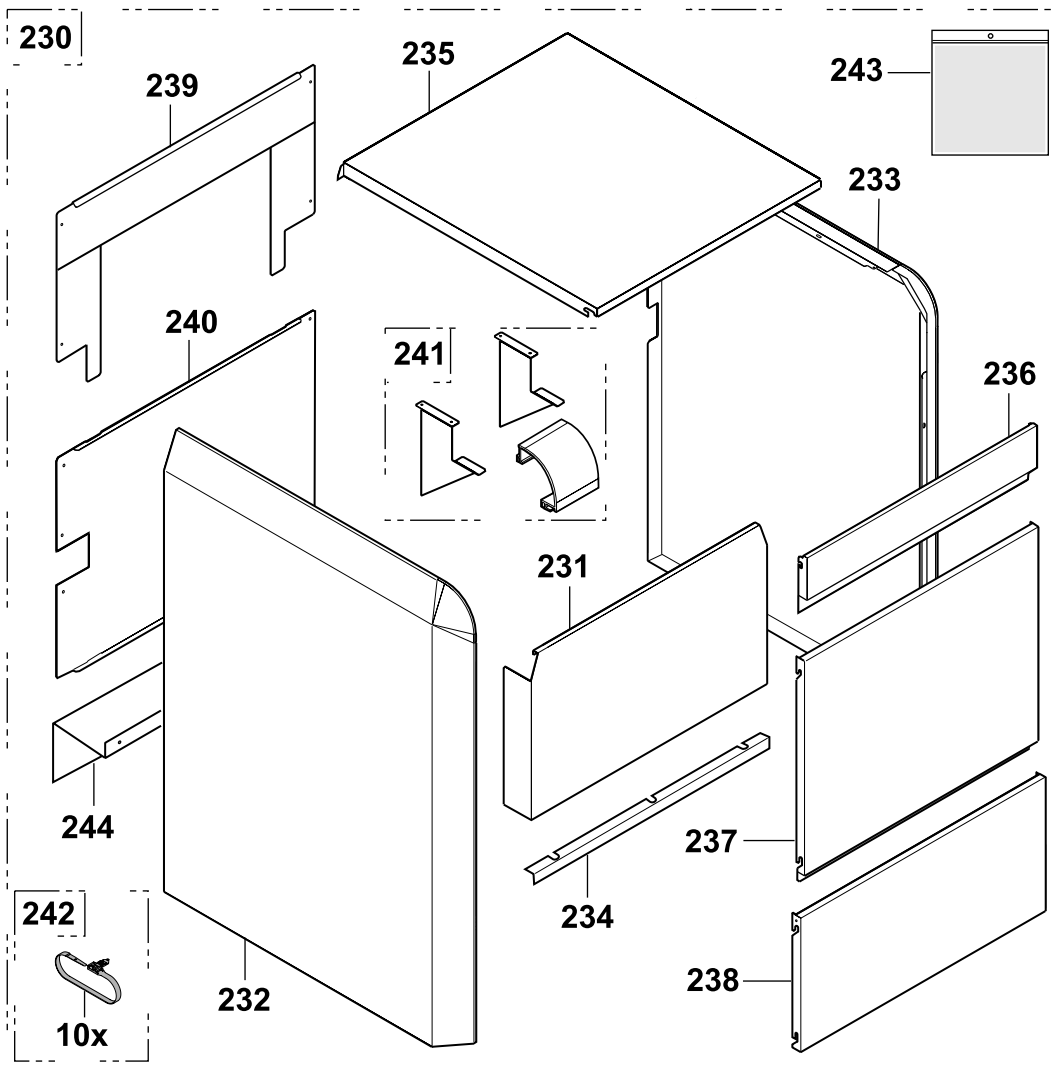

8358N098A

Markers	Code no.	Description
		BOILER BODY
1	8358-5500	Boiler body - 8 sections
1	8358-5502	Boiler body - 10 sections
1	8358-5504	Boiler body - 12 sections
1	8358-5505	Boiler body - 14 sections
1	8358-5506	Boiler body - 16 sections
1	8358-5507	Boiler body - 18 sections
1	8358-5508	Boiler body - 20 sections
2	8358-5509	Lateral section left
3	8358-5510	Lateral section right
4	8358-5511	Intermediate section
5	8116-0571	Nipple
6	8800-8966	Box of mastic (1 kg)
7	9430-5027	Putty for nipple 300g
8	8345-7020	Assembly rod LG670
8	8345-7022	Assembly rod Ø 10 x 870
8	8345-7024	Assembly rod Ø 10 x 1010
8	8345-7025	Assembly rod Ø 10 x 1195
8	8345-7026	Assembly rod Ø 10 x 1370
8	8345-7027	Assembly rod Ø 10 x 1550
8	8358-5512	Assembly rod M10 - 1730
9	9536-5611	Sensor tube 1/2"
10	9758-1286	Contact spring for thimble tube
11	8358-5554	Return pipe + Gasket - 8 sections
11.1	8358-5582	Return pipe + Gasket - 10 sections
11.2	8358-5560	Return pipe + Gasket - 12-16 sections
11.3	8358-5555	Return pipe + Gasket - 18-20 sections
12	8358-5553	Outlet pipe + Gasket
13	9758-1697	Plain square flange
14	9758-1119	Square flange with tapped hole 1/2"
15	9758-1630	Flange gasket
16	9495-0110	Plug 1/2"
17	9495-0140	Plug 3/4"
18	8345-0501	Locating lug
19	9750-5037	Brush
		BASE FRAME + DRAUGHT DIVERTER
20	8358-8501	Draught diverter complete - 8 sections
20	8358-8503	Draught diverter complete - 10 sections
20	8358-8505	Draught diverter complete - 12 sections
20	8358-8506	Draught diverter complete - 14 sections
20	8358-8507	Draught diverter complete - 16 sections

Markers	Code no.	Description
20	8358-8508	Draught diverter complete - 18 sections
20	8358-8509	Draught diverter complete - 20 sections
21	8116-8078	Nozzle Ø 250 - 8 sections
21	8345-8217	Nozzle Ø 300 - 10-12 sections
21	8345-8218	Nozzle Ø 350 - 14-18 sections
21	8123-8193	Nozzle Ø 400 - 20 sections
22	8358-5513	Sweeping plate - 8 sections
22	8358-5515	Sweeping plate - 10 sections
22	8358-5517	Sweeping plate - 12 sections
22	8358-5518	Sweeping plate - 14 sections
22	8358-5519	Sweeping plate - 16 sections
22	8358-5520	Sweeping plate - 18 sections
22	8358-5521	Sweeping plate - 20 sections
23	9587-0055	M6 wing nut
24	8358-8050	Rear upper cross-bar - 8 sections
24	8358-8052	Rear upper cross-bar - 10 sections
24	8358-8054	Rear upper cross-bar - 12 sections
24	8358-8055	Rear upper cross-bar - 14 sections
24	8358-8056	Rear upper cross-bar - 16 sections
24	8358-8057	Rear upper cross-bar - 18 sections
24	8358-8058	Rear upper cross-bar - 20 sections
25	8358-5561	Sweeping plate seal
26	9428-5095	Silicone filler tube
27	8358-5522	Fixing screw
31	8358-8739	Complete frame 8 sections
31	8358-8741	Complete frame 10 sections
31	8358-8743	Complete frame 12 sections
31	8358-8744	Complete frame 14 sections
31	8358-8745	Complete frame 16 sections
31	8358-8746	Complete frame 18 sections
31	8358-8747	Complete frame 20 sections
32	9758-1180	Central foot, rear
33	8358-8706	Complete combustion chamber - 8 sections
33	8358-8708	Complete combustion chamber - 10 sections
33	8358-8710	Complete combustion chamber - 12 sections
33	8358-8711	Complete combustion chamber - 14 sections
33	8358-8712	Complete combustion chamber - 16 sections
33	8358-8713	Complete combustion chamber - 18 sections

Markers	Code no.	Description
33	8358-8714	Complete combustion chamber - 20 sections
34	8358-8791	Complete combustion chamber insulation - 8 sections
34	8358-8793	Complete combustion chamber insulation - 10 sections
34	8358-8795	Complete combustion chamber insulation - 12 sections
34	8358-8796	Complete combustion chamber insulation - 14 sections
34	8358-8797	Complete combustion chamber insulation - 16 sections
34	8358-8798	Complete combustion chamber insulation - 18 sections
34	8358-8799	Complete combustion chamber insulation - 20 sections
35	9422-9236	Front insulation - 8 sections
35	9422-9238	Front insulation - 10 sections
35	9422-9240	Front insulation - 12 sections
35	9422-9241	Front insulation - 14 sections
35	9422-9242	Front insulation - 16-18-20 sections
36	9422-9277	Rear insulation - 8 sections
36	9422-9279	Rear insulation - 10 sections
36	9422-9281	Rear insulation - 12 sections
36	9422-9282	Rear insulation - 14 sections
36	9422-9283	Rear insulation - 16-18-20 sections
37	9422-9284	Side insulating material
38	8358-5557	Fixing screw
39	8358-1560	Painted tank - 8 sections
39	8358-1562	Painted tank - 10 sections
39	8358-1564	Painted tank - 12 sections
39	8358-1565	Painted tank - 14 sections
39	8358-1566	Assembled tank - 16 sections
39	8358-1567	Assembled tank - 18 sections
39	8358-1568	Assembled tank - 20 sections
40	9422-9286	Tank insulation - 8 sections
40	9422-9288	Tank insulation - 10 sections
40	9422-9290	Tank insulation - 12 sections
40	9422-9291	Tank insulation - 14 sections
40	9422-9292	Tank insulation - 16 sections
40	9422-9293	Tank insulation - 18 sections
40	9422-9294	Tank insulation - 20 sections
		BOILER BODY INSULATION
41	8358-5523	Insulating material for body - 8 sections
41	8358-5525	Insulating material for body - 10 sections

Markers	Code no.	Description
41	8358-5527	Insulating material for body - 12 sections
41	8358-5528	Insulating material for body - 14 sections
41	8358-5529	Insulating material for body - 16 sections
41	8358-5530	Insulating material for body - 18 sections
41	8358-5531	Insulating material for body - 20 sections
42	8358-4004	Rear insulation - 8 sections
42	8358-4006	Rear insulation - 10 sections
42	8358-4008	Rear insulation - 12 sections
42	8358-4009	Rear insulation - 14 sections
42	8358-4010	Rear insulation - 16 sections
42	8358-4011	Rear insulation - 18 sections
42	8358-4012	Rear insulation - 20 sections
43	8358-4014	Upper front insulation - 8 sections
43	8358-4016	Upper front insulation - 10 sections
43	8358-4018	Upper front insulation - 12 sections
43	8358-4019	Upper front insulation - 14 sections
43	8358-4020	Upper front insulation - 16 sections
43	8358-4021	Upper front insulation - 18 sections
43	8358-4022	Upper front insulation - 20 sections
44	8358-4024	Lower front insulation - 8 sections
44	8358-4026	Lower front insulation - 10 sections
44	8358-4028	Lower front insulation - 12 sections
44	8358-4029	Lower front insulation - 14 sections
44	8358-4030	Lower front insulation - 16 sections
44	8358-4031	Lower front insulation - 18 sections
44	8358-4032	Lower front insulation - 20 sections
45	8358-4033	Side insulation, right - 8-10-12 sections
45	8358-4034	Side insulation, right - 14-16-18-20 sections
46	8358-4035	Side insulation, left - 8-10-12 sections
46	8358-4036	Side insulation, left - 14-16-18-20 sections
47	8358-4038	Upper insulation - 8 sections
47	8358-4040	Upper insulation - 10 sections
47	8358-4042	Upper insulation - 12 sections
47	8358-4043	Upper insulation - 14 sections
47	8358-4044	Upper insulation - 16 sections
47	8358-4045	Upper insulation - 18 sections
47	8358-4046	Upper insulation - 20 sections
48	8406-8082	Fastening
		CONTROL PANEL K
69	200003771	Control panel

Markers	Code no.	Description
71	200003824	Front panel support + CMF facade cladding
73	9421-0705	Control panel front cover K
74	9536-5157	Flat thermometer
75	8500-0002	Thermostat adjustable from 30 to 90°C
76	8500-0032	Safety thermostat 110°C
77	9521-6281	Round green indicator
78	8555-5501	Setting button + Pin
79	9532-5027	Green S/S bipolar switch
80	9532-5102	Reset switch
81	8500-0034	Momentary bipolar switch
82	8500-0035	Bipolar switch
83	9534-0288	4A TS710/4A Circuit-breaker
84	8358-4900	Control panel harness K
85	200001996	Safety box RV 0054100000
86	9532-5103	Bipolar switch
88	8358-4907	1-5 connector, assembled DGAI. 73
89	8358-4904	Power supply harness
90	8358-4912	3 pin IT-AMP circuit
91	8358-4905	Ionisation sensor circuit
92	200003258	Harness for third party control unit
93	9758-1286	Spring for pocket
94	8502-5519	Fasteners
95	8358-4908	1-6 connector, assembled DGAI. 73
96	8358-4909	7-8 connector, assembled DGAI. 73
		METAL CASING FOR CONTROL PANEL K
140	8358-8720	Protection cap
141	8358-5559	Card supports
142	8358-5558	Control panel bracket
143	8502-5560	Piano hinges (2 items)
144	8387-5556	Flap
		GAS LINE - 20 MBAR
150	8388-8696	Gas line - 8 sections
150	8358-8698	Gas line - 10 sections
150	8358-8700	Gas line - 12 sections
150	8358-8701	Gas line - 14 sections
150	8358-8702	Gas line - 16 sections
150	8358-8703	Gas line - 18 sections
150	8358-8704	Gas line - 20 sections
151	9536-1561	Valve MB-ZRDLE 410B01

Markers	Code no.	Description
151	9536-1562	Valve MB-ZRDLE 412B01
151	9536-1563	Valve MB-ZRDLE 415B01
152	9496-0535	Union elbow 1"
152	9496-0536	Union elbow 1"1/4
152	9496-0537	Union elbow 1"1/2
153	9501-3064	Green seal 44x32x2
153	9501-3065	Green seal 56x42x2
153	9501-3066	Green seal 62x46x2
154	9754-9204	Clamp + Plug 1"
154	9754-9205	Clamp + Plug 1"1/4
154	9754-9213	Clamp + Plug 1"1/2
155	9754-9212	Gas flange with pressure socket 1"
155	9536-1003	Gas flange with pressure socket 1"1/4
155	9754-9214	Gas flange with pressure socket 1"1/2
156	8358-5583	Pilot burner pipe
157	9754-9216	Knob
158	9764-6000	Gas pressostat
190	8358-5563	Burner support - 8 sections
190	8358-5565	Burner support - 10 sections
190	8358-5567	Burner support - 12 sections
190	8358-5568	Burner support - 14 sections
190	8358-5569	Burner support - 16 sections
190	8358-5570	Burner support - 18 sections
190	8358-5571	Burner support - 20 sections
191	8358-5572	FURIGAS burner + Screw
192	8358-5573	Insulation, burner drawer - 8 sections
192	8358-5575	Insulation, burner drawer - 10 sections
192	8358-5577	Insulation, burner drawer - 12 sections
192	8358-5578	Insulation, burner drawer - 14 sections
192	8358-5579	Insulation, burner drawer - 16 sections
192	8358-5580	Insulation, burner drawer - 18 sections
192	8358-5581	Insulation, burner drawer - 20 sections
	8800-8961	Glue 1000 (100 ml can)
193	8358-8280	Burner stiffener - 8 sections
193	8358-8282	Burner stiffener - 10 sections
193	8358-8284	Burner stiffener - 12 sections
193	8358-8285	Burner stiffener - 14 sections
193	8358-8286	Burner stiffener - 16 sections
193	8358-8287	Burner stiffener - 18 sections
193	8358-8288	Burner stiffener - 20 sections
194	8358-8760	FURIGAS complete pad
195	9755-3151	Ignition transformer ANSTOS
196	9654-4002	Anti-parasite filter

Markers	Code no.	Description
197	9532-0579	Feed through
198	9532-0186	Cable clamp
199	8358-8228	Top cover
200	8358-4913	3 pin AMP cable - filter
201	8358-4906	Ignition transformer cable - spark plug
202	8358-4914	Earth wire
203	8358-4915	Black wire, filter - ignition transformer
204	8358-4916	Blue wire, filter - ignition transformer
205	8350-4911	Gas line connector
206	8350-4915	Gas pressure switch connector
207	8358-8601	Ignition burner
208	9758-0449	Ignition burner injector
209	9536-1580	Ignition burner valve
210	9494-8065	Nipple N245 1/4" x 1/8"
211	9492-6030	Tee 1/4"
212	9494-6035	Nipple N280 1/4"
212	9494-8055	Nipple N241 1/4" x 1/8"
214	9536-0220	Pressure socket
215	8358-8338	Flame non-return plate - 8 sections
215	8358-8340	Flame non-return plate - 10 sections
215	8358-8342	Flame non-return plate - 12 sections
215	8358-8343	Flame non-return plate - 14 sections
215	8358-8344	Flame non-return plate - 16 sections
215	8358-8345	Flame non-return plate - 18 sections
215	8358-8346	Flame non-return plate - 20 sections
		CIRCUIT SEPARATION TRANSFORMER
761	9654-1620	Circuit separation transformer
762	8358-8737	Screws
763	8358-4922	Cable conductor
		CLADDING
230	200003920	Cladding complete - 8 sections
230	200003921	Cladding complete - 10 sections
230	200003922	Cladding complete - 12 sections
230	200003923	Cladding complete - 14 sections
230	200003924	Cladding complete - 16 sections
230	200003925	Cladding complete - 18 sections
230	200003926	Cladding complete - 20 sections
231	8358-8618	Complete front cladding support - 8 sections
231	8358-8620	Complete front cladding support - 10 sections

Markers	Code no.	Description
231	8358-8622	Complete front cladding support - 12 sections
231	8358-8623	Complete front cladding support - 14 sections
231	8358-8624	Complete front cladding support - 16 sections
231	8358-8625	Complete front cladding support - 18 sections
231	8358-8626	Complete front cladding support - 20 sections
232	8358-6572	Lateral panel complete left
233	8358-6573	Lateral panel complete right
234	8358-8208	Holding bracket - 8 sections
234	8358-8210	Holding bracket - 10 sections
234	8358-8212	Holding bracket - 12 sections
234	8358-8213	Holding bracket - 14 sections
234	8358-8214	Holding bracket - 16 sections
234	8358-8215	Holding bracket - 18 sections
234	8358-8216	Holding bracket - 20 sections
235	8358-0621	Painted cover - 8 sections
235	8358-0623	Painted cover - 10 sections
235	8358-0625	Painted cover - 12 sections
235	8358-0626	Painted cover - 14 sections
235	8358-0627	Painted cover - 16 sections
235	8358-0628	Painted cover - 18 sections
235	8358-0629	Painted cover - 20 sections
236	200003470	Upper front panel - 8 sections
236	200003471	Upper front panel - 10 sections
236	200003472	Upper front panel - 12 sections
236	200003473	Upper front panel - 14 sections
236	200003474	Upper front panel - 16 sections
236	200003475	Upper front panel - 18 sections
236	200003576	Upper front panel - 20 sections
237	200003513	Inside front panel - 8 sections
237	200003514	Inside front panel - 10 sections
237	200003515	Inside front panel - 12 sections
237	200003516	Inside front panel - 14 sections
237	200003517	Inside front panel - 16 sections
237	200003518	Inside front panel - 18 sections
237	200003519	Inside front panel - 20 sections
238	8358-8947	Complete lower front panel - 8 sections
238	8358-8949	Complete lower front panel - 10 sections
238	8358-8951	Complete lower front panel - 12 sections
238	8358-8952	Complete lower front panel - 14 sections
238	8358-8953	Complete lower front panel - 16 sections
238	8358-8954	Complete lower front panel - 18 sections

Markers	Code no.	Description
238	8358-8955	Complete lower front panel - 20 sections
239	8358-8938	Upper rear panel - 8 sections
239	8358-8940	Upper rear panel - 10 sections
239	8358-8942	Upper rear panel - 12 sections
239	8358-8943	Upper rear panel - 14 sections
239	8358-8944	Upper rear panel - 16 sections
239	8358-8945	Upper rear panel - 18 sections
239	8358-8946	Upper rear panel - 20 sections
240	8358-8306	Lower back panel - 8 sections
240	8358-8308	Lower back panel - 10 sections
240	8358-8310	Lower back panel - 12 sections
240	8358-8311	Lower back panel - 14 sections
240	8358-8312	Lower back panel - 16 sections
240	8358-8313	Lower back panel - 18 sections
240	8358-8314	Lower back panel - 20 sections
241	8358-6583	Additional part - 8 sections
241	8358-6585	Additional part - 10 sections
241	8358-6587	Additional part - 12 sections
241	8358-6588	Additional part - 14 sections
241	8358-6589	Additional part - 16 sections
241	8358-6590	Additional part - 18 sections
241	8358-6591	Additional part - 20 sections
242	8358-5562	10 collar kit
243	8358-8629	Housing screws packet
244	8358-8327	Deflector, rear panel

NL Remeha B.V.
Postbus 32
7300 AA APELDOORN
Tel: +31 55 5496969
Fax: +31 55 5496496
Internet: nl.remeha.com
E-mail: remeha@remeha.com

E D.A.C. S.A.
Tomás A. Edison 29
Poligono Cogullada
50014 ZARAGOZA
Tel: +34 76 464076
Fax: +34 76 471311
Internet: www.dac.es
E-mail: dac@dac.es

GB Broag Ltd.
Remeha House
Molly Millars Lane
RG41 2QP WOKINGHAM, Berks.
Tel: +44 118 9783434
Fax: +44 118 9786977
Internet: uk.remeha.com
E-mail: boilers@broag-remeha.com

E Norte Comercial Organización S.A.
Bereteage Bidea, 19
48180 LOIU (Vizcaya)
Tel: +34 94 471 03 33
Fax: +34 94 471 11 52
E-mail: nco@nco.es

B J.L. Mampaey BVBA
Uitbreidingstraat 54
2600 ANTWERPEN
Tel: +32 3 2307106
Fax: +32 3 2301153
Internet: www.mampaey.be
E-mail: info@mampaey.be

IRL Euro Gas Ltd.
Unit 38, Southern Cross Business Park
Boghall Road, Bray, Co
WICKLOW
Tel: +353 12868244
Fax: +353 12861729
Internet: www.eurogas.ie
E-mail: sales@eurogas.ie

B Thema S.A.
6, Avenue de l'expansion
4460 GRACE-HOLLOGNE
Tel: +32 4 2469575
Fax: +32 4 2469576
Internet: www.thema-sa.be
E-mail: info@thema-sa.be

H Marketbau - Remeha Kft.
Gyár u. 2.
Ipari Park
2040 BUDAÖRS
Tel: +36 23 503 980
Fax: +36 23 503 981
Internet: www.remeha.hu
E-mail: remeha@remeha.hu

E Termibarna S.A.
C. Zamora 55-59
08005 BARCELONA
Tel: +34 3 3000204
Fax: +34 3 3009558

E Cuatrocesa S.A.
c) Sor Angela de La Cruz, 10
- 1º Oficina C
28020 MADRID
Tel: +34 91 658 18 88
Fax: +34 91 658 30 77

© Copyright

All technical and technological information contained in these technical instructions, as well as any drawings and technical descriptions supplied, remain our property and shall not be multiplied without our prior consent in writing..

Ours is a policy of continuous development. We reserve the right to alter specifications without prior notification

Subject to alterations