

BoilerMate II

**A central heating and mains pressure
hot water supply system incorporating
a thermal store.**

Design, Installation and Servicing Instructions

**PLEASE LEAVE THESE
INSTRUCTIONS ADJACENT TO
THE APPLIANCE.**

**ALL MODELS COMPLY WITH THE
BRITISH GAS SPECIFICATION FOR
INTEGRATED THERMAL STORES.**

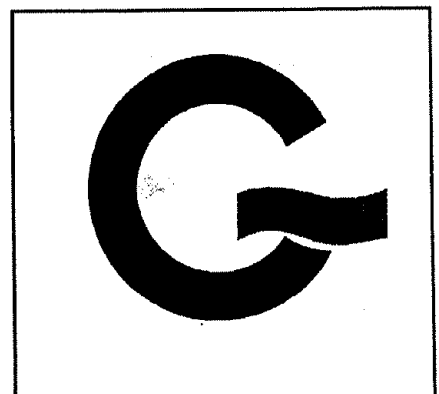

GLEDHILL BOILERMATE SPECIFICATION

DESCRIPTION	PAGES 2 - 5
SYSTEM DESIGN	PAGES 6 - 10
INSTALLATION	PAGES 11 - 15
COMMISSIONING	PAGES 16 - 17
PROBLEM SOLVING	PAGES 18 - 22
SERVICING	PAGES 23 - 24
APPENDICES	PAGES 25 - 29
PERFORMANCE SPECIFICATIONS	PAGES 30 - 31
SHORT PARTS LIST	PAGE 32
SALE & WARRANTY TERMS	PAGE 33

These instructions should be read in conjunction with the installation/servicing instructions issued by the manufacturer of the heat source being used.

Any installation must be in accordance with the relevant requirements of the Gas Safety Regulations, Local Building Regulations, I.E.E. Wiring Regulations and Byelaws of the Local Water Undertaking. It should be read in accordance with the relevant recommendations of the following:

BS 6798; BS 5449; BS 5546;
BS 5440:1; BS 5440:2; CP 331:3;
BS 6700; BS 5258 and BS 7593: 1992.

It must be installed by a competent person as stated in the Gas Safety Regulations.
Manufacturers notes must NOT be taken as over-riding statutory obligations.

BoilerMate is not covered by section G.3 of the 1985 Building Regulations and is therefore not notifiable to the Building Control Office.

Although the secondary supply (domestic) is at mains pressure, it is not necessary to fit an expansion chamber, pressure or temperature relief valve. BoilerMate is only suitable for use with a vented primary system.

This information is provided to assist generally in the selection of equipment.

Responsibility for selection and specification of our equipment must however remain that of our customer and any experts or consultants concerned with the installation (s).

PLEASE NOTE: THAT WE DO NOT THEREFORE ACCEPT ANY RESPONSIBILITY FOR MATTERS OF DESIGN SELECTION OR SPECIFICATION, FOR THE EFFECTIVENESS OF AN INSTALLATION OR UNIT CONTAINING ONE OF OUR PRODUCTS.

All goods are sold subject to our Conditions of Sale which are set out at the rear of this specification. In the interest of continuously improving the BoilerMate range, Gledhill Water Storage Ltd reserve the right to modify the product without notice, and in these circumstances this booklet, which is accurate at the time of printing, should be disregarded.

**A UK - WFBS LISTED PRODUCT
DEVELOPED IN CONJUNCTION WITH
BRITISH GAS PLC
GAS COUNCIL NO. 89-317-02**

**BRITISH PATENT NOS. 1358166, 2136099
BRITISH PATENT APPLICATIONS
PUBLISHED UNDER NOS. 2136099,
2153503, 2153504, 8516025**

DESCRIPTION

INTRODUCTION

The BoilerMate is used to provide improved space heating as well as a mains pressure hot water supply system for use with any boiler sited remotely. A report by the Cranfield Institute of Technology found that heat storage systems give a potential for energy savings of between 5% and 15%. A boiler of any output up to a maximum of 100,000 BTU can be linked to any suitable model of BoilerMate and the deciding factor is the hot water requirement (see Model Selection Data, page 5). The principle of BoilerMate is to separate the heat generator (e.g. the boiler) from heat emitters by a thermal store, which evens out the fluctuating demands for heating and hot water. Thus by storing energy produced when demand is low and discharging it when demand is high (i.e. during warm-up or when hot water is drawn off) a smaller boiler can be used. An important feature of this design is that hot water can be supplied directly from the mains at conventional flow rates without the need for temperature and pressure safety relief valves or expansion vessels.

THERMAL STORE

The thermal store contains primary water which is maintained at a temperature close to the boiler flow temperature in winter. The store temperature can be reduced in the summer-time by the user by means of the store temperature control on the front panel of the BoilerMate. It is efficiently insulated with rockwool insulation in a galvanised steel case to minimise standing losses.

DOMESTIC HOT WATER

COLD SUPPLY

BoilerMate models are designed to be fed directly from mains. They fulfil the requirements of Water Byelaw 91, and therefore **do not require a check valve** to be fitted to the supply pipe. The performance of the BoilerMate is directly related to the adequacy of the cold supply to the dwelling. This must be capable of providing for those services which could be required simultaneously and the maximum demand should be calculated. BoilerMate will operate at pressures as low as 1 bar which must be available when local demand is at its maximum, but the preferred range is between 2 and 3.5 bar. Between 1 and 2 bar simultaneous demand capability will be affected and a low resistance model (140, 180, 200, 220 or 125) should be specified.

As a general guideline, although a 15mm external service may be sufficient for the smaller dwelling with one bathroom, a 22mm service is preferred (25mm MDPE) and should be the minimum for larger dwellings.

If a water meter is fitted in the service pipe, it should have a nominal rating to match the anticipated maximum simultaneous hot and cold water demand, calculated in accordance with BS 6700. This could be 50 litres per minute in some properties.

If the incoming static mains water pressure exceeds 3.5 bar at any point in the 24 hour cycle then a pressure limiting valve set at 3.5 bar should be fitted downstream of the stop tap where the cold supply enters the property. Units must be fitted strictly in accordance with the requirements of the Local Water Undertaking who should be consulted prior to installation. In the event of any difficulty please contact us as the manufacturer. Equipment used in the system should be suitable for a working pressure of 10 bar.

SAFETY FITTINGS

It is not necessary to fit the control and safety equipment normally associated with mains pressure supply since the unit contains its own patented expansion chamber which is sealed for life. In the event of failure of this chamber, the system will relieve at the toilet ballvalve provided:

1. It is plumbed in accordance with Figure 1.
2. The property contains at least one ballvalve which complies with BS 1212 Part 2 or 3 pattern open to the system expansion.

3. BoilerMate is WBS listed. A non-return valve is NOT required. Should ancillary equipment fitted in the supply to these appliances require a non-return valve then this valve must be fitted directly after the branch to the drinking water tap (kitchen sink). "A check valve must **never** be fitted to the final cold inlet branch to the BoilerMate.

DOMESTIC FLOW RATE

Provided that the pipe sizing is adequate, the hot flow at the tap is determined by the local mains pressure, but should be up to 20 litres/min on Models 115 and 120, up to 26 litres/min on Models 140 and 125, up to 28 litres/min on Model 180, up to 30 litres/min on Model 200 and up to 35 litres/min on Model 220 according to the temperature set by the user and the amount of cold water blended in.

EXTERNAL EXPANSION VESSEL

This is not necessary with BoilerMate.

USE IN HARD WATER AREAS

The patented design of the heat exchange module is such that the turbulence through the coil slows down the formation of scale in even the hardest water conditions, at normal operating pressures. Where the water can be considered hard, it is recommended that an effective proprietary in-line scale inhibitor is installed. It is important that where the supply to the BoilerMate is in 22mm the in-line descaler is also 22mm. In practice the servicing requirements can be considered similar to those needed for instantaneous or 'combi' appliances.

The installation of the scale inhibitor should be in accordance with the manufacturers instructions and with the Water Byelaws.

Alternatively, periodic on-site descaling can be conveniently carried out using a special valve obtainable from ourselves. See Page 23 for full instructions.

The advice of a specialist Water Treatment Company should be sought if in doubt.

DESCRIPTION

Figure 1

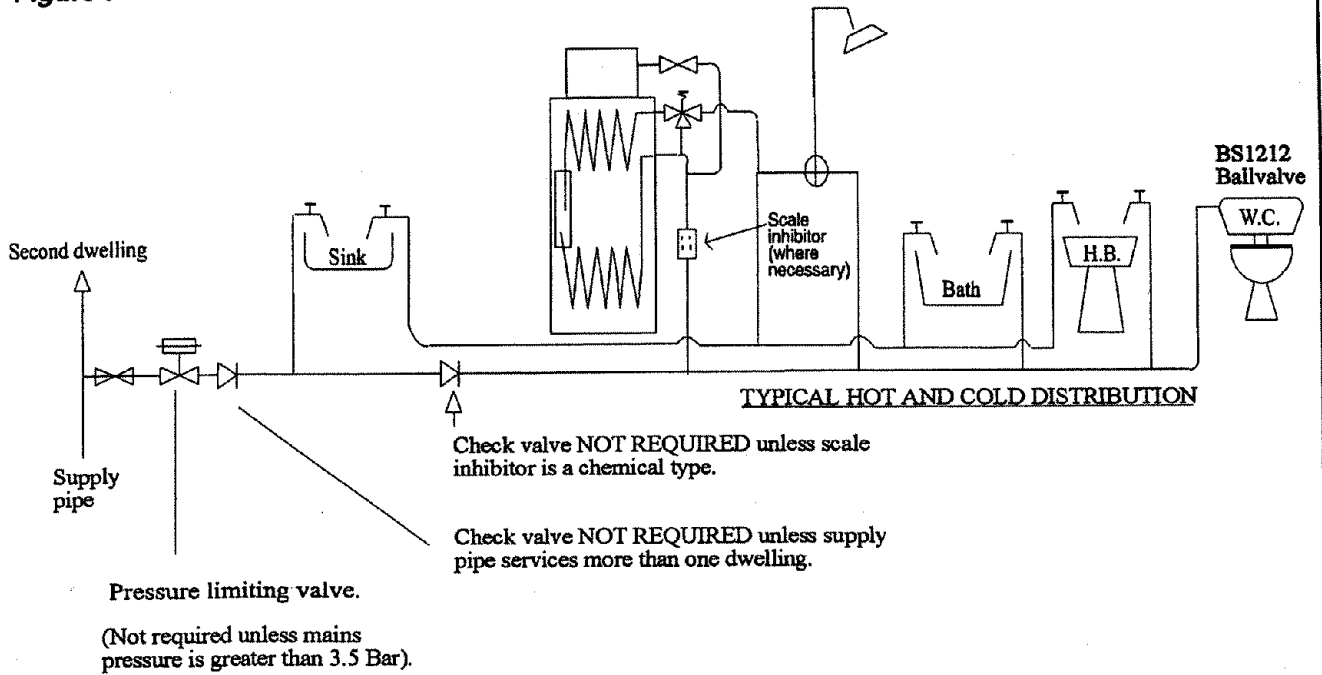

Note:

The cold feed to the BoilerMate should approach from below to avoid heat creepage during idle periods.

CONTROLS

Figure 2

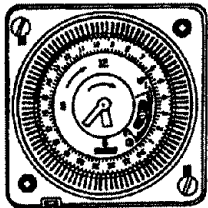

ELECTRO-MECHANICAL CLOCK

Figure 3

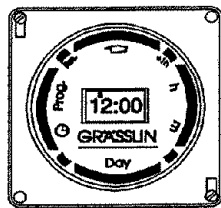

DIGITAL CLOCK
DIGITAL CLOCK

PACKAGED CONTROL SYSTEM

BoilerMate is supplied as standard with an electro-mechanical clock to control the space heating (see Figure 2). A seven day digital clock is available as an alternative (see Figure 3). The clock/programmer, together with a room thermostat, if fitted, controls the heating system pump. If required a kit is available to site the clock/programmer remotely or a no clock option is available for use with any 2 channel clock (see page 27). The boiler is controlled by the store thermostat.

FIGURE 4

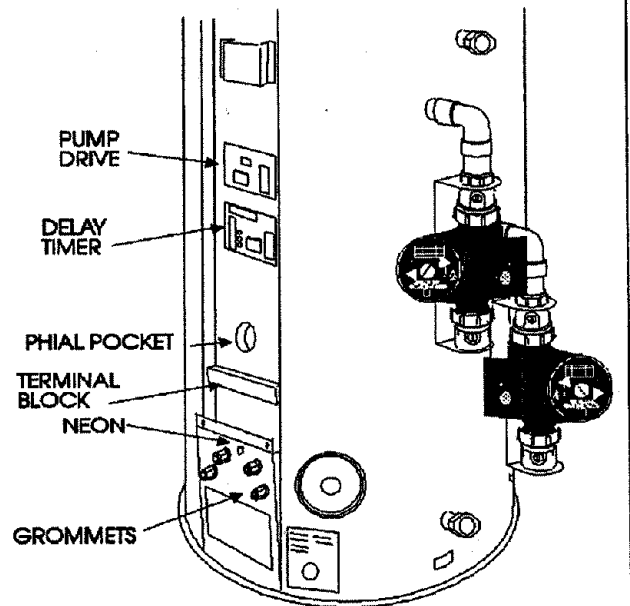

STORE THERMOSTAT

Store thermostat is the principal control mechanism and the correct type is therefore important. This will be supplied as part of the control package.

DESCRIPTION

PACKAGED CONTROL SYSTEM

Figure 5

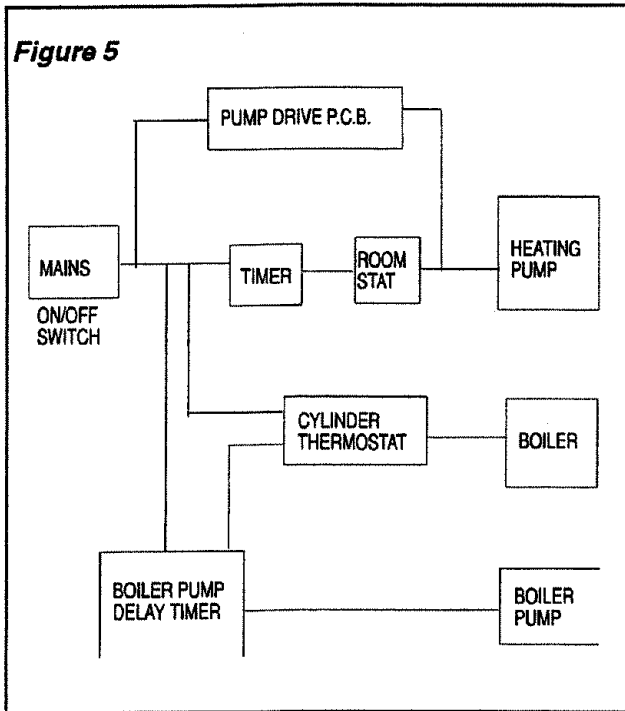

ELECTRICAL IMMERSION HEATER

If an electric immersion heater is fitted it must:

- a. be set to operate at 80 °C
- b. be wired to its own power source by a 13amp fuse and **not through the cylinder terminal block or time clock** which should be protected with a 3 amp fuse.

DELAY TIMER

A delay timer is pre-wired into the BoilerMate wiring loom.

The delay timer is activated by the switched live from terminal 7 and the link between terminals 4 and 8. This aids system economy by removing all the hot water from the boiler each time it shuts down.

PUMP DRIVE P.C.B.

This is pre-wired into the BoilerMate wiring loom. Its purpose is to prevent the heating pump from becoming seized during the summer period. It does this by automatically switching the pump on for a few seconds approximately every 40 hours.

DESCRIPTION

MODEL SELECTION DATA - CIRCULAR PATTERNS

MODEL	STORE CAPACITY APPROX	HOT WATER FLOW RATE	DIMENSIONS OF THERMAL STORE OVER INSULATION	MINIMUM CUPBOARD SIZE	TAPPINGS	SUGGESTED DWELLING TYPE	
	Litres	l/m	height x diameter	width x depth			
FE 120	120	20	1500 x 500	700 x 600	All connections on the models 120, 140, 180 are for 22mm pipe unless specified differently at time of order. All connections are for 28mm pipe on the model 200, 220 unless specified differently at time of order. Two & a quarter inch IHB tapping supplied as standard. Half inch Fern BSP for drain supplied as standard. Units will be supplied with all tappings on the right hand side unless specifically requested handed.	2/3 bedroom house with one bathroom and/or shower	**
FE 140	120	32	1500 x 500	700 x 600		2/3 bedroom house with one bathroom and separate en-suite shower room	**
FE 180	150	32	1520 x 550	750 x 600		2/3/4 bedroom house with one bathroom and one or two separate en-suite shower rooms	**
FE 200	180	32	1730 x 550	750 x 600		3/4 bedroom house with one bathroom and up to 3 separate en-suite shower rooms or 2 bathrooms & 2 separate en-suite shower rooms	**
FE 220	200	35	1870 x 550	750 x 600		3/5 bedroom house with two bathrooms and up to 3 separate en-suite shower rooms	***

GUIDE TO MODEL SELECTION DATA - RECTANGULAR PATTERNS

MODEL	STORE CAPACITY APPROX	HOT WATER FLOW RATE	DIMENSIONS OF THERMAL STORE OVER INSULATION	MINIMUM CUPBOARD SIZE	TAPPINGS	SUGGESTED DWELLING TYPE	
	Litres	l/m	height x width x depth	width x depth			
FE 115	120	20	1780 x 320 x 545	550 x 600	All connections are for 22mm pipe. Two & a quarter inch IHB tapping supplied as standard. Half inch Fern BSP for drain supplied as standard. Units will be supplied with all tappings on the right hand side unless specifically requested handed.	2/3 bedroom house with one bathroom and/or shower	**
FE 125	120	32	1780 x 320 x 545	550 x 600		2/3 bedroom house with one bathroom and separate en-suite shower room	**

NOTES:

1. All BoilerMates meet the requirements of the British Gas Specification for Integrated Thermal Stores.

** Cat SC2

*** Cat SC3

2. Models 140, 180, 200, 220 and 125 have low resistance, high flow rate heat exchangers. They are particularly suited to areas where the water pressure is lower than normal.

3. The flow rates shown are with the Brawa-mix valve set to give 35 °C rise and assume normal pressure and an adequate flow to the appliance.

4. All units are supplied complete with an integral feed and expansion tank. This is easily removed from any circular model and repositioned remotely up to 6m above the base of the store if necessary. It will fit in any space greater than 500mm high by 500mm square,

which includes the necessary allowance for ballvalve servicing.

5. Please ask for details if the BoilerMate is for use with a central boiler (CB) installation.

6. Any pattern of BoilerMate can be specified 'ET' for use with dual boilers (see page 9).

7. With integrated thermal storage, it is important to recognise that hot water and heating loads can be supplied simultaneously.

SYSTEM DESIGN

Figure 6

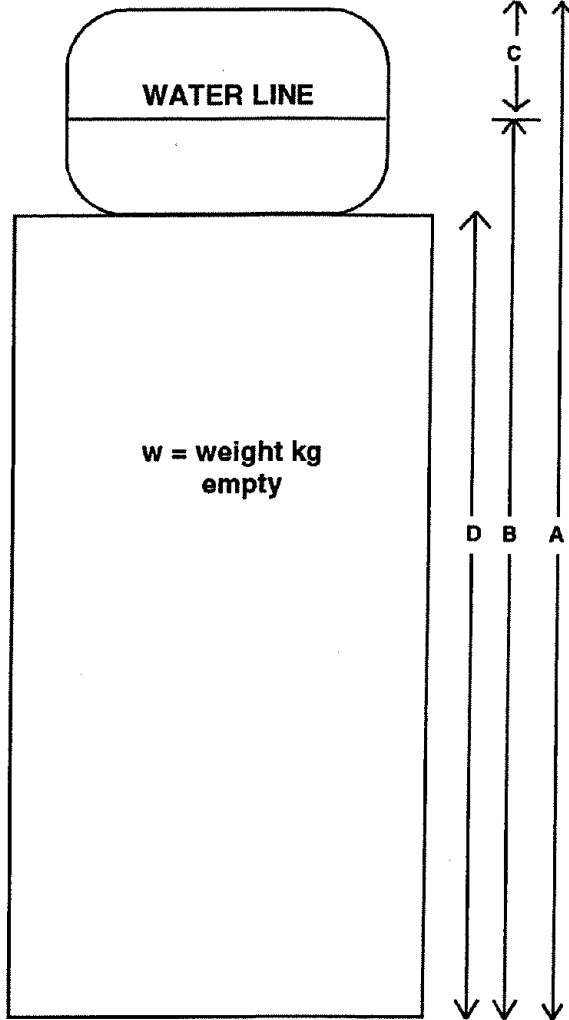

MODEL	A	B	C	D	W
120	1500	1350	150	1250	49
140	1500	1350	150	1250	53
180	1520	1360	160	1250	55
200	1730	1570	160	1460	61
220	1870	1710	160	1600	67
115	1780	1600	180	-	60
125	1780	1600	180	-	63

METHOD OF SIZING

The efficiency of this system is such that special design criteria apply when calculating the boiler size. It is only necessary to calculate the heating requirements in accordance with BS 5449 and add the following allowances for hot water which are approximately half the traditional allowances.

- Up to 1 bathroom & shower - 1.5kW
- Up to 2 bathrooms & 2 showers - 3.0 kW
- Up to 3 bathrooms & 2 showers - 4.0 kW

The primary pipes should be sized to achieve a 6 ° C temperature rise across the boiler, but in any case should be not less than 22mm.

HEAT SOURCE - SYSTEM DESIGN

BOILER SITED BELOW BOILERMATE

Any boiler can be used when the flow to the BoilerMate rises continuously without valves. No part of the flow should contain a valve, as this forms the open vent should the boiler thermostat fail. The recommended control system to give the most energy efficient operation is shown in Figure 7.

Figure 7

BOILER SITED BELOW BOILERMATE

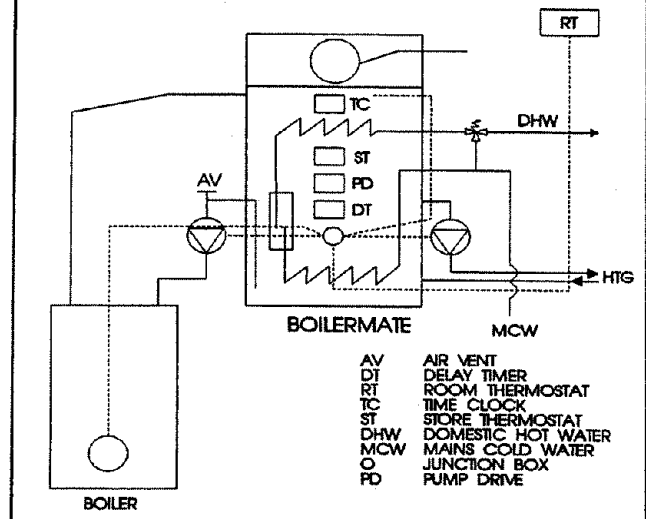

BOILERMATE is supplied as a factory fitted and pre-wired package consisting of:

- a. Pump between boiler and thermal store.
- b. Pump for radiator circuit.
- c. Store thermostat.
- d. Central heating timer.
- e. Junction box.
- f. Thermostatic mixing valve.
- g. Boiler pump delay timer P.C.B.
- h. Pump drive P.C.B.

SYSTEMS WITH DIPPED FLOW & RETURN AND BOILERS WITH OVERHEAT THERMOSTAT

If the flow and return between the boiler and the thermal store (BoilerMate) are dipped the boiler should be fitted with an overheat thermostat. In these circumstances manual air vents should be fitted as in Figure 8. In situations where headroom is restricted (eg. in a flat) the boiler manufacturer's instructions with regard to minimum head must be followed.

In the case of the Baxi Solo 2, however, the boiler may be installed in accordance with Figure 8A. The F&E cistern may be left attached to the store, and the whole BoilerMate raised on a stillage.

Refer to Figure 6 for water levels.

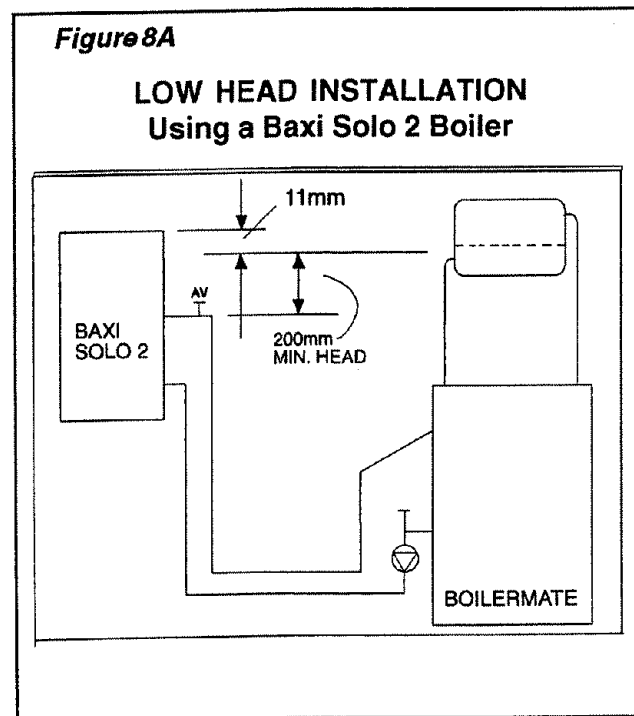
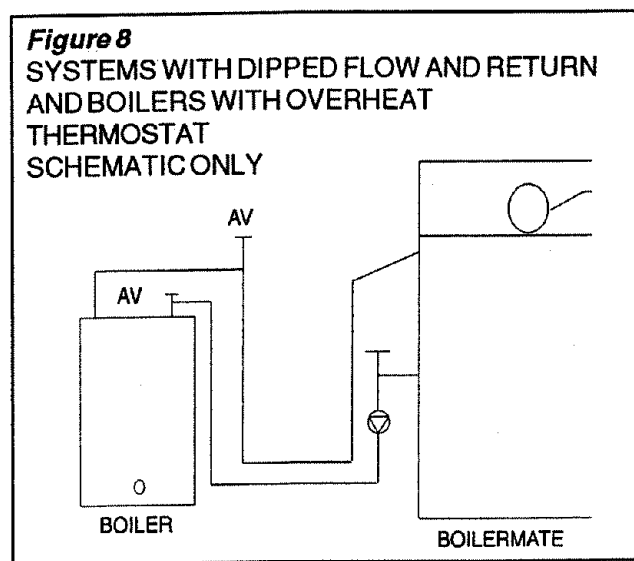
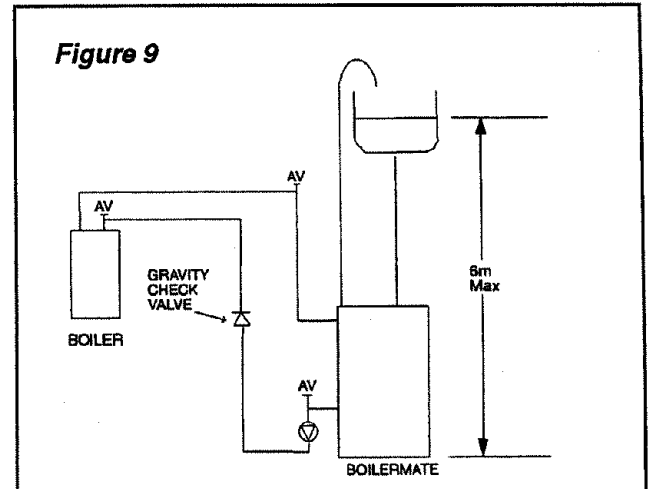

Figure 9 shows an alternative layout using a BoilerMate with the F & E cistern remotely situated.



If the boiler is higher than the BoilerMate (as in Figure 9) a gravity check valve is necessary as shown to prevent gravity circulation from the BoilerMate to the boiler during dormant periods.

SYSTEMS WITH DIPPED FLOW & RETURN AND BOILERS WITHOUT OVERHEAT THERMOSTAT

Where a boiler of a type which does not have an overheat thermostat is fitted so that the flow and return between the boiler and the thermal store are dipped, special criteria apply.

In order to comply with British Standards, the expansion pipe must rise continuously from the boiler. See Figure 10 overleaf.

Plastic Pipework

This appliance is suitable for use with plastic pipework as long as the material is recommended for the purpose by the manufacturer and is installed fully in accordance with their recommendations.

We recommend the use of barrier pipe, which will mean the system can have BritishGas service cover in regions offering this service.

SYSTEM DESIGN

Figure 10

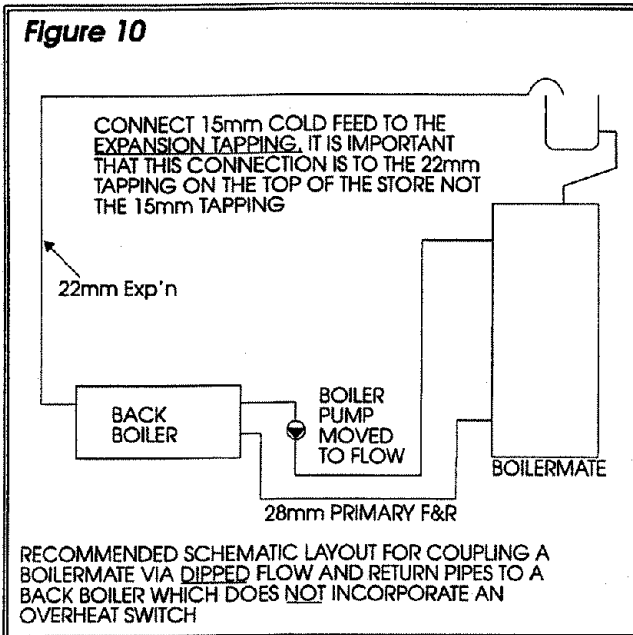

Figure 10 illustrates a method of coupling a back boiler without an overheat switch to a BoilerMate in a situation with limited headroom (eg. in a flat). The cold feed is connected to the expansion tapping, and the expansion pipe is run directly from the boiler.

The pump is moved to the boiler flow to avoid pumping over. The flow and return pipes are increased to 28mm to minimise the pressure reduction at the boiler when the pump is running.

If an electric immersion heater is fitted into a BoilerMate plumbed in this way it should be of a type fitted with a thermal cut-out (eg. Redring model 30/302201). The cold feed tapping should be plugged. In these circumstances, the open vent from the boiler to the feed and expansion tank should be a minimum of 22mm diameter copper tube or equivalent and should rise continuously from the boiler to discharge above the feed and expansion cistern. The feed pipe should not be less than 15mm copper tube or equivalent.

GENERAL NOTES FOR GUIDANCE ON SYSTEM DESIGN

If summer heating of a bathroom radiator or towel rail is required, then it **must** be piped in accordance with Figure 11.

This involves moving the boiler pump so that the radiator return can be teed in upstream of the pump. Any other way would degrade the flow temperature into the BoilerMate, and is incorrect.

It must be remembered that the heating of such a radiator will be intermittent i.e. it will only heat up whilst the boiler is actually firing.

The radiator lockshield valve should be throttled down so that it does not draw an excessive flow out of the flow to the BoilerMate.

Figure 11

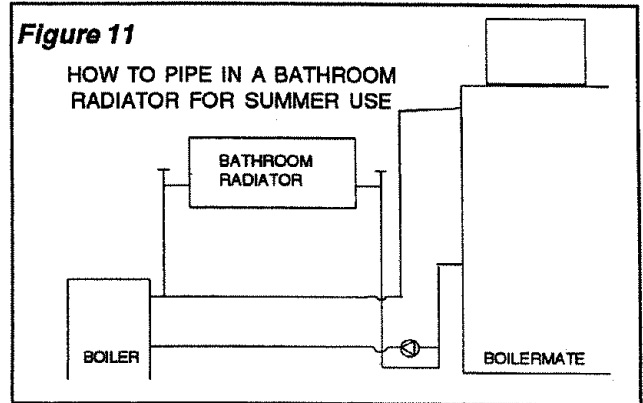

The radiator circuit in Figure 7 is controlled by the heating circuit pump through the action of the room thermostat and time clock.

For fuel economy and best boiler performance, the system should be designed so that gravity circulation does not take place in the heating system when the pump is not running. It is often necessary to fit a check valve to be certain of preventing this.

If the boiler is fitted at a higher level than the BoilerMate, it may be necessary to fit a gravity check valve on the primary circuit to prevent reverse circulation during dormant periods.

All units come complete with their own feed and expansion tank. The water level in this tank should be at least 250mm above the highest point on the radiator circuit. The F & E cistern may be detached from any circular model and fitted remotely up to 6m above the base of the thermal store.

The overflow/warning pipe should be installed in a material suitable for Feed and Expansion cisterns in accordance with BS 5449.

A by-pass is **not needed** in the circuit between boiler and thermal store as the latter performs this function. It may be necessary, however, to fit one on the heating circuit if TRV's are fitted on all radiators.

A METHOD OF COUPLING GAS & SOLID FUEL BOILERS TO BOILERMATE

Many of your customers would like their solid fuel open fire or boiler to make a useful contribution to their automatic gas-fired central heating system.

Until now, this has required a whole array of controls, and installers have been deterred, either by the cost, or the complexity, or both. Where BoilerMate is used as the heart of the system there is no problem. BoilerMate is the neutral point of the installation and can therefore accept heat from more than one source without upsetting the other. The heat from the secondary source can be fed to the BoilerMate either by gravity or pumped circulation.

If it is required to use heat from a solid fuel boiler then this must be piped in conjunction with a gas (or other automatic) boiler, so as to ensure that the store will be maintained at full temperature.

Figure 12 is a suggested method of doing this.

The high limit thermostat on the solid fuel boiler flow pipe should be wired across BoilerMate terminals 4 and 10. It should close on temperature rise, and be set to (say) 90°C. This will then switch on the heating pump, thus dispersing the excess heat into the radiators.

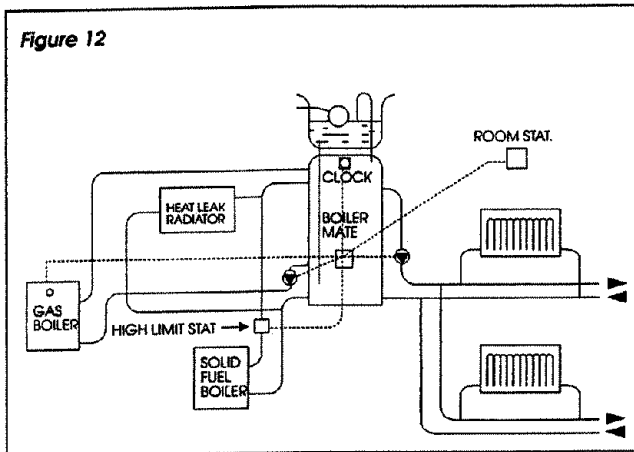

To order BoilerMate for dual boiler use specify model 'ET'. Price and delivery will be confirmed by our Technical Sales Office.

TAPS & VALVES

Hot and cold taps and mixing valves used with the unit must be suitable for operating at 10 bar pressure. **Aerated taps are recommended to prevent splashing.**

PIPE SIZING

To achieve even distribution of the available supply, it is important in any mains pressure system that piping in the dwelling should be sized in accordance with BS 6700 particularly in large or multi bathroomed properties, however the rule of thumb guidelines following this paragraph should be adequate for most typical domestic property types.

1. A 15mm external service may be sufficient for the smaller 1 bathroom dwelling (depending on the flow rate available), but the minimum size for larger dwellings is 22mm (25mm MDPE).
2. The internal cold feed from the stop tap to the BoilerMate should be run in 22mm tubing. The hot draw off should also be run in 22mm as far as the branch to the bath tap.
3. **The tee-offs to basins/sinks should be in 10mm:** the tee-offs to the bath and showers should be in 15mm.

4. Tee-offs to taps in existing property which are in 15mm **should be restricted** to balance flow to each outlet.

5. Best results are achieved by fitting appropriate flow regulators to each hot and cold outlet (see page 28).

6. **Any surface pipework in the BoilerMate cupboard should be insulated to reduce standing losses and cupboard temperatures.**

SHOWERS

Either thermostatic or manual showers and mixer valves can be used as long as both hot and cold are mains fed, however thermostatic valves will provide better control. The hot water supply to a shower mixing valve should be fed directly from the BoilerMate and where practical should be the first draw-off point on the hot circuit. The cold supply to a shower mixing valve should be fed directly from the rising main via an independent branch.

Showers - Fixed Head Type:

No anti-syphonage arrangements are necessary.

Showers - Loose or Flexible Head Type:

If a loose head shower with flexible hose is to be used over a bath, the hose must be fixed so that the head cannot fall closer than 25mm (as specified in Byelaw 16 of the Water Supply Byelaws) above the top edge of the bath in order that the head is prevented from being immersed in bath water, or the shower must incorporate or be fitted with an anti-syphonage device at point of flexible hose connection.

BIDETS

The supply of hot and cold mains water direct to bidet is permitted provided that this bidet is of the over-rim flushing type and that a type 'A' air gap is incorporated. It must not include either an ascending spray or provision to attach a hand spray.

SYSTEM DESIGN

SCHEMATIC PLUMBING AND HEATING LAYOUT FOR BOILERMATE IN A TYPICAL HOUSE WITH BATH AND SEPARATE SHOWER

Heating

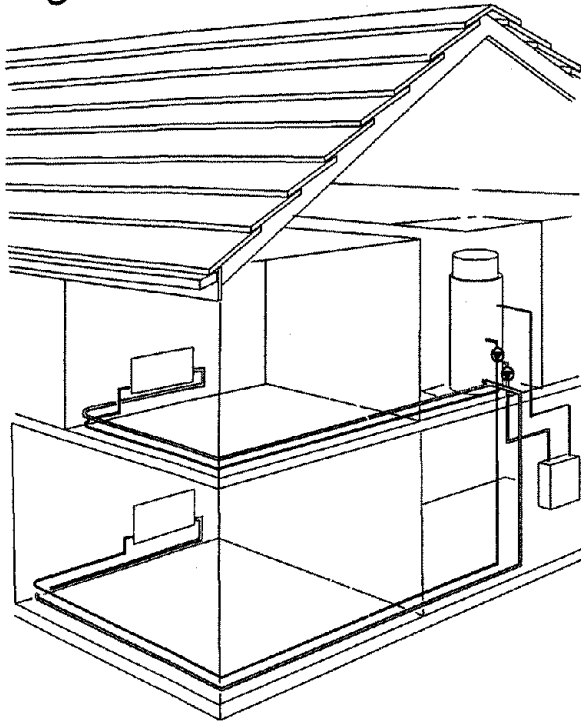

NOTES

The flow and return from the boiler always run directly to the BoilerMate and the flow should rise continuously to facilitate venting.

Where this is not possible, refer to pages 7&8.

The heating circuit is taken from the BoilerMate, and is piped in the conventional manner.

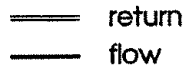

Plumbing

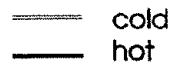
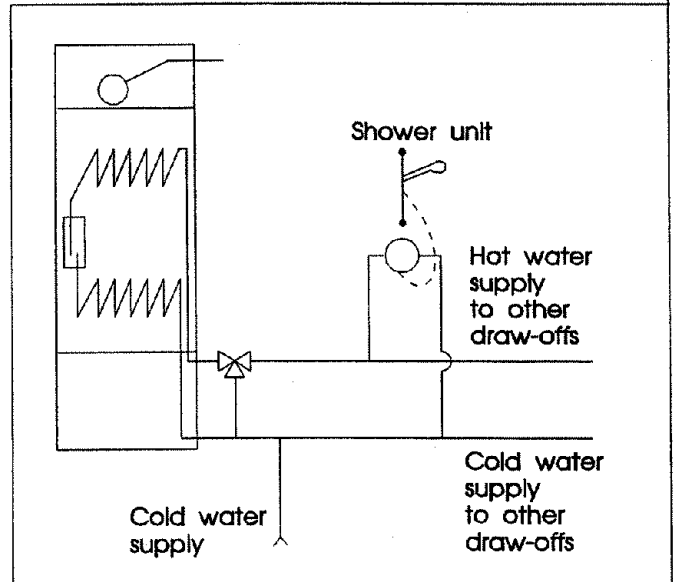
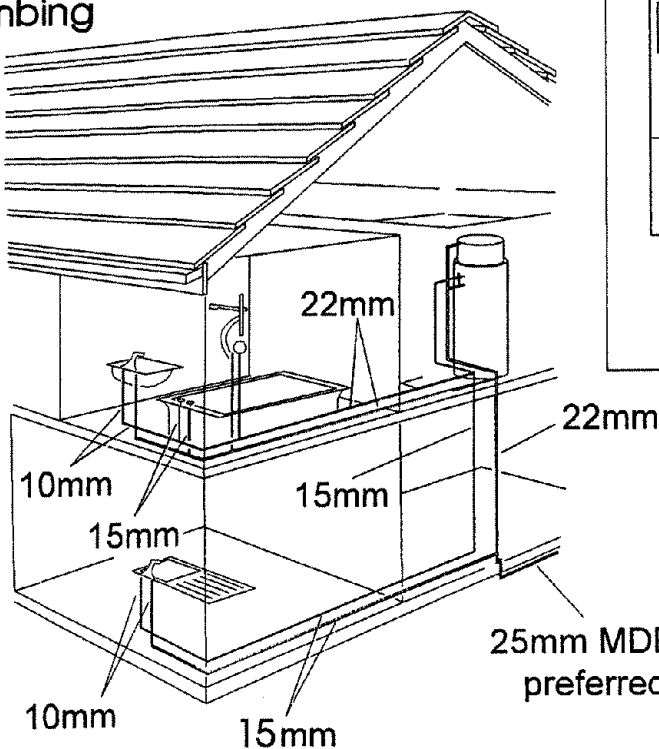

INSTALLATION INSTRUCTIONS

IMPORTANT NOTES

- a) It is important that the appliance is installed on a level and even floor or if raised above the base should be continuously supported. If the support is timber, it shall be marine ply, type C4 chipboard to B.S.5669 or other material which will not deteriorate if exposed to moisture. Details of the appliance weight when full is provided in Table 1.1 of technical specifications.

NOTE:

1. INSTALLERS ARE ADVISED THAT COMBINED FEED AND VENT PIPES MUST NOT BE USED IN BOILERMATE INSTALLATIONS.

2. IT IS RECOMMENDED IN ACCORDANCE WITH APPROVED DOCUMENT L OF THE BUILDING REGULATIONS THAT SURFACE PIPEWORK IN THE BOILERMATE CUPBOARD BE INSULATED TO REDUCE STANDING LOSSES AND TO PREVENT UNNECESSARILY HIGH CUPBOARD TEMPERATURES. MORE HEAT IS LOST FROM THE FIRST METRE OF PIPEWORK THAN FROM THE STORE.

3. NOT WITHSTANDING THE ABOVE, CUPBOARD TEMPERATURES ARE NORMALLY HIGHER THAN IN A CONVENTIONAL SYSTEM AND THE DESIGN OF BOTH THE CUPBOARD AND THE DOOR SHOULD TAKE THIS INTO ACCOUNT.

PLUMBING CONNECTIONS

NB: The water connections on a BoilerMate are reversed when compared with a conventional system i.e. the heating flow and return are taken directly from the thermal store and the domestic water is taken to and from the coil.

COMBINED FEED & EXPANSION CISTERN

- It is most important to adjust the fitted ballvalves whilst the system is cold to give a water level of 50mm above the feed outlet to the primary system to allow adequate room for expansion (this is marked by a corrugation in the wall of the tank).
- Sufficient space should be left above the unit to allow access to the ballvalve for servicing and adjustment.
- A 22mm compression fitting is provided as standard in the feed and expansion cistern for the overflow/warning pipe, which should be no less than 20mm internal diameter.

This should be fitted to discharge clear of the building and be situated so that any overflow can be easily observed.

The warning pipe should be installed in either high temperature uPVC or copper and should not have any other connections to it.

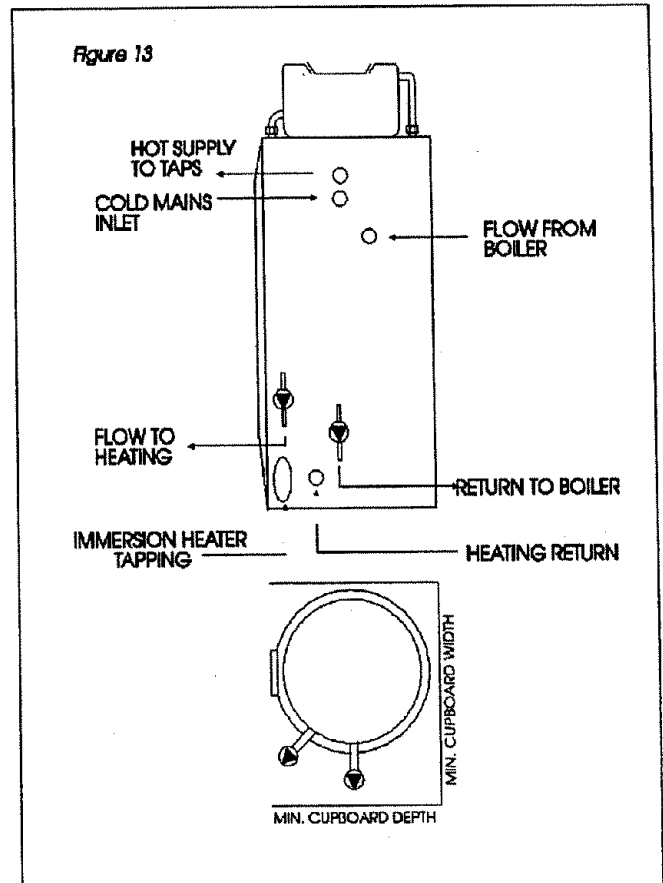

All BoilerMates are for vented primary systems only. A sealed system primary unit is not available.

PLUMBING CONNECTIONS

Make all water connections in accordance with the labelling on the thermal store and associated pipework. If the incoming static mains water pressure exceeds 3.5 bar at any point in the 24 hour cycle then a pressure limiting valve set at 3.5 bar should be fitted downstream of the stop tap where the cold supply enters the property. If a boiler is fitted above the thermal store, a gravity check valve should be incorporated in the connecting pipework leading from the BoilerMate to the boiler, i.e. the boiler return.

All factory made joints should be checked after installation in case they have loosened during transit.

INSTALLATION

PRIMARY TEMPERATURE

The system operates on the normal primary flow temperature of the boiler and any traditional hot water radiator or convector can be used with the system.

DOMESTIC HOT WATER TEMPERATURE

A Brawa-Mix valve is fitted for the control of domestic hot water by the user.

The DHW flow rates shown on pages 2 and 5 are for water raised through 35°C.

To increase or decrease the temperature rotate the valve head as shown in Figure 14.

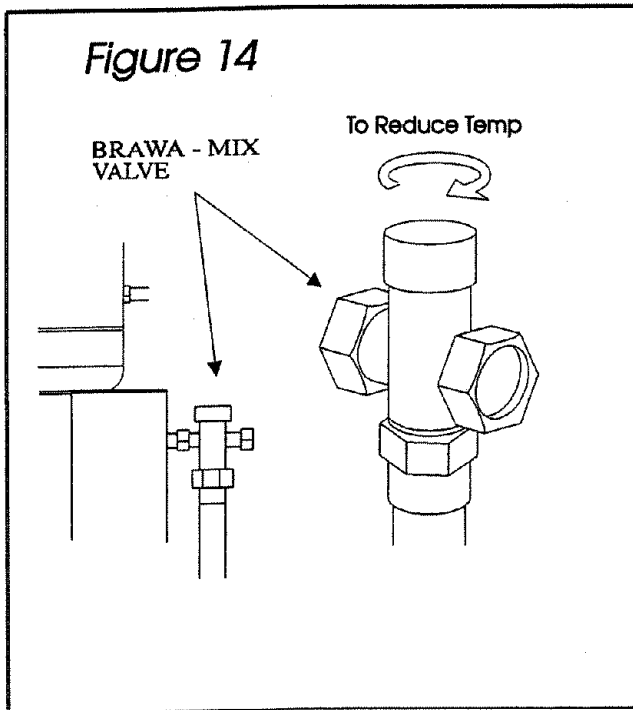

BOILER THERMOSTAT SETTING

This should always be set to maximum to give the best hot water service and to achieve the highest efficiency by reducing boiler cycling.

RANGE RATED APPLIANCES

Where a range rated boiler is used it should always be set at the **highest** output. System efficiency will not be impaired, while the recovery rate is improved.

PUMP SETTINGS

The pumps in the control package must be set in the following way:

- a. The pump (lower) between boiler and BoilerMate should be set to as high a level as possible consistent with low noise levels so that the temperature difference across the boiler is approximately 6°C.
- b. The pump on the heating circuit must be set by the installer to give a temperature difference across the radiator circuit of 11°C in the usual way.

THE GLEDHILL BOILERMATE INSTALLATION INTEN EASY STEPS

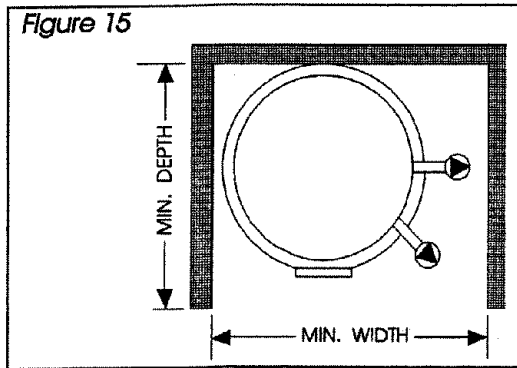

BoilerMate installation is easier and quicker than conventional vented systems because there is no secondary feed tank to bother with.

1. Inspect the position in which BoilerMate is to be fitted and check that the internal depth is at least 600mm and the width 700mm for models 120 and 140 and 750mm for models 180, 200 and 220.

2. Plan the pipe connections. Each fitting on BoilerMate has its own label. You need to connect the following pipes:

- Pumped flow and return pipes, from the body of the BoilerMate to the boiler.
- Pumped flow and return pipes from the body of the BoilerMate to the radiators.
- Cold mains water supply connections to the inlet side of the domestic hot water heating coil and to the ballvalve in the F & E cistern.
- Domestic hot water supply pipe from the delivery of the DHW mixing valve to the taps.
- Overflow warning pipe from the F & E cistern to discharge in a conspicuous position externally.

3. If you are fitting the cistern remotely, check the route of the 22mm diameter open safety vent pipe and of the 15mm diameter feed and expansion pipe from the BoilerMate to cistern position. Also check the route of the overflow warning pipe. All the BoilerMate connections are clearly labelled.

When you have decided where the pipes are to run, check the space required for them inside the BoilerMate compartment.

4. Decide at what stage in your installation work you are going to fit the BoilerMate. We would suggest that in most cases the BoilerMate should be fitted first and pipes run from it to the boiler, radiators and domestic hot water supply system subsequently in that order.

5. Remember that a by-pass is not needed for any boiler as the thermal store acts as the by-pass itself.

6. Carry out the rest of the installation work, ie boiler, radiators and hot water supply pipework. Connect the cold water supply pipework.

7. Fill the BoilerMate, radiators, boiler and pipework with water through the F & E cistern. Adjust the ballvalve so that when cold there is just enough water in the cistern to float the ball. Flush the system out, fill again and vent.

8. Fill the domestic hot water heating coil with water and establish a flow through to the taps etc. Check that flow through all hot and cold water taps etc. is stopped when the mains water stop valve is closed.

9. The system now requires to be electrically connected.

10. The system is now ready to be commissioned.

INSTALLATION

WIRING THE SYSTEM

See Figure 16

Because BoilerMate is pre-wired to a central control panel, plumbers are well able to complete the electrical installation provided they adhere strictly to the IEE Regulations. Do not attempt the electrical work unless you are competent to carry it out to the above standards.

ISOLATOR

Connection to the electrical supply must allow complete electrical isolation by installing a fused double pole switch having 3mm separation on both sides. The isolating switch must only serve the heating and hot water system, together with its controls"

TO WIRE THE BOILERMATE

Before commencing, ensure that the power source to which it is intended to connect the system is isolated.

1. Remove thermostat knob and pointer.
2. Remove white cover plate (4 screws) and connector block cover (pull off).
3. From a 3 amp fused and switched connection unit bring a live, neutral and earth to the BoilerMate connector block.
Live to terminal 1.
Neutral to terminal 2.
Earth to terminal 3.
4. Leave in link 1 joining BoilerMate terminals 4 and 8.
5. Take a live from BoilerMate terminal 7 to boiler switched live input.
6. Take a neutral from BoilerMate terminal 5 to boiler neutral.
7. Take an earth from BoilerMate terminal 6 to boiler earth.
8. If the boiler needs a permanent live *other than for a pump over-run*, then this should be taken from terminal 4.
9. The link between 9 and 10 should be removed if a room thermostat is to be fitted.
10. If a Maxol 600, a Maxol Morocco or a Maxol Microturbo 40 is used refer to Appendix 3, Page 27.

11. If a Baxi Solo 2 is used, then its integral frost thermostat should be ignored. If frost protection is required, then a separate frost thermostat should be wired across terminals 4 and 7 on the BoilerMate terminal block, and set to 5°C.

When using the Baxi Solo 2 boiler a permanent live supply should not be provided from the BoilerMate terminal block. Instead a link should be provided from the 'L' to the 'S/L' terminal on the boiler. In the few situations where boilers do require a permanent live it is most important that extra care is taken in the wiring of the permanent and switched live supplies. If adequate separation is not provided the switched live circuit can be affected resulting in the neon and boiler pump running permanently.

Figure 16

BOILERMATE WIRING DIAGRAM

(For Remote Fixing of the Clock, see Appendix 1, page 25)

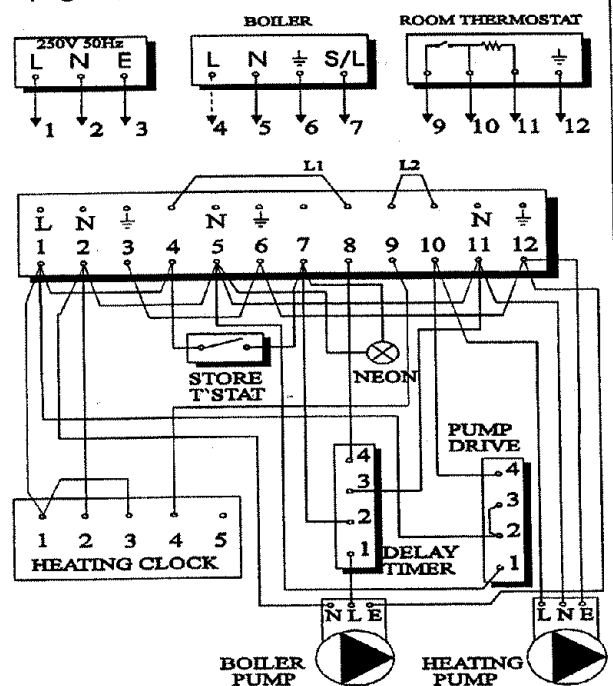

Boiler permanent live is not normally required. See note 8

Figure 17
FLOW DIAGRAM

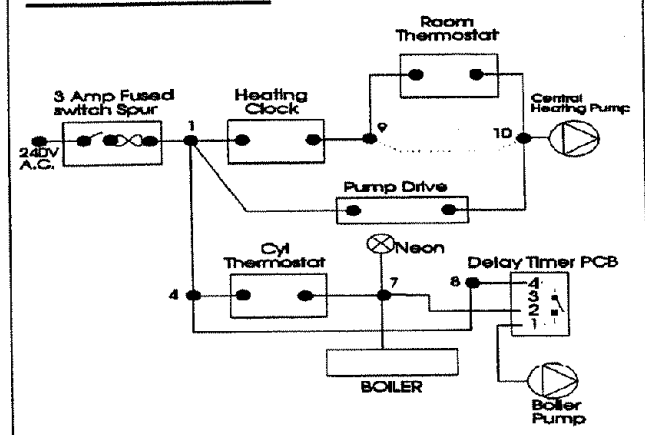

When the wiring is completed, replace the front panel and the store thermostat knob and pointer.

Set the pointer to the maximum temperature.

TO WIRE IN A ROOM THERMOSTAT TO BOILERMATE

1. Remove link 2 joining BoilerMate terminals 9 and 10.
2. From BoilerMate terminal 9 take a live to the live connection on room thermostat.
3. From room thermostat switched live connection take a live to BoilerMate terminal 10.
4. Connect BoilerMate terminal 11 to room thermostat neutral.
5. Connect BoilerMate terminal 12 to room thermostat earth (if required).

FROST PROTECTION

Where frost protection is required for the boiler only, a frost thermostat should be wired across terminals 4 and 7. Where frost protection is required for the whole house, or where a base temperature is required during cold weather, a frost thermostat should be wired across terminals 4 and 9. Ensure that this thermostat is set to +1 or +2°C, and the room thermostat set down to the required temperature. If a Baxi Solo 2 is used, see paragraph 11 on previous page.

An alternative to fitting a frost thermostat would be to set the programmer to constant during the cold weather period.

DELAY TIMER

A delay timer is pre-wired into the BoilerMate wiring loom. The delay timer is activated by the switched live from terminal 7 and the link between 4 and 8. This aids system economy by removing all the hot water from the boiler each time it shuts down.

COMMISSIONING

COMMISSIONING THE SYSTEM

It is essential that the system functions properly for optimum performance. To achieve this, the system should be commissioned in accordance with good practice and generally in accordance with the requirements of BS 6798, BS 5449 and BS 7593: 1992. Ensure that the float is correctly adjusted to close the ball valve at the water level line inside the F&E cistern. Fill the system and flush cold.

Refill the system.

Add a cleanser such as Sentinel X300 to ensure that flux residues and installation debris are removed from the system. **When determining the quantity of cleanser required, be sure to allow for the increased volume of water in the primary circuit due to the thermal store.**

Commission the boiler.

If the boiler is range rated, then adjust to the maximum heat input. Set the pump between boiler and BoilerMate (lower mounted pump) to give a high flow rate. A temperature difference across the boiler of say 6°C is near the optimum. In practice, the highest pump setting that does not produce system noise gives the best BoilerMate performance but the temperature difference should not be above 10°C.

To ensure full cleansing, circulation to all parts of the system should continue for a minimum of 1 hour.

Flush the system hot having checked that there is no overflow when the system is up to temperature.

Refill the system.

Although the standard BoilerMate has no special water treatment requirements, the radiators and other parts of the circuit will benefit from the application of a corrosion and scale inhibitor, such as Sentinel X100, a multi-metal corrosion and scale inhibitor manufactured by BetzDearborn. **When determining the quantity of inhibitor required, be sure to allow for the increased volume of water in the primary circuit due to the thermal store.**

Set boiler thermostat to maximum.

With the central heating system off, let the system heat up (with a 30,000 Btu boiler 1.5 hours approximately). Turn on the space heating system and adjust the space heating pump speed to give a temperature difference of 11°C.

Check that the space heating system controls are functioning correctly ie: **CLOCK AND ROOM THERMOSTAT.**

Switch off space heating system.

Ensure that the store thermostat is set to maximum.

Ensure that the boiler thermostat is set to maximum. Establish that the temperature difference between the flow and return at the boiler is not more than 10°C, and preferably (say) 6°C.

If it is more than 10°C, and the pipes are sized correctly, then there is some restriction in the primary flow or return pipe. Check that in accordance with good practice, air vents have been fitted at high points. Increase the pump setting if necessary. Check for obstructions in the pipework.

FINAL SETTING OF STORE THERMOSTAT

Ensure that the heating clock is set to " off ".

Refire the boiler by running a little water, wait for the boiler to switch off. If the commissioning light is still lit at this stage then immediately turn the temperature control down slowly until the commissioning light at the bottom of the panel goes out.

Turn the control finger one more hole down and insert a plastic peg immediately above it and push home hard to prevent accidental 'decommissioning'. Spare pegs are stored at the top of the panel.

IMPORTANT DO'S AND DON'TS

DO

Check the incoming mains water pressure. If it exceeds 3.5 bar at any point in the 24-hour cycle then a pressure limiting valve set at 3.5 bar should be fitted where the cold supply enters the property, see page 3.

DO

Check that all connections are in accordance with the labelling on the thermal store.

DO

Adjust the ball valve so that there is just enough water in the F&E cistern to float the ball when cold.

DO

Make sure there is adequate clearance above the F&E cistern to service the valve.

DO

Ensure that range-rated appliances are set at the **highest** output and the **boiler thermostat is set to maximum for all boilers.**

DO

Ensure that the water level in the expansion cistern is at least 250mm above the highest point on the radiator circuit.

DO

Insulate any exposed pipework in the BoilerMate cupboard.

DO

Plumb the overflow warning pipe in 20mm minimum internal diameter tubing to discharge in a conspicuous external position, using high temperature uPVC or copper.

COMMISSIONING

DO

Check the pump settings

1. The pump between boiler and BoilerMate (the lower pump) should be set as high as possible (consistent with not creating noise) so as to give a small temperature difference across the boiler, say 6°C.
2. The pump on the radiator circuit (the higher pump) must be set so as to give a temperature difference across the radiator circuit of 11°C in the usual way.

DON'T

Use a combined feed and vent on BoilerMate installations.

DON'T

Use a BoilerMate on sealed primary systems.

DON'T

Use tube smaller than 28mm between boiler and BoilerMate when the boiler exceeds 60,000 Btu (17kW) output.

DON'T

Use dipped flow and return pipes between boiler and BoilerMate unless:

1. The boiler is fitted with an overheat switch, **OR**
2. The boiler is directly vented to a feed and expansion cistern. (See page 8 System Design).

PROBLEM SOLVING

FAULTS AND THEIR CAUSES

Any faults in the system design and malfunctions of system components will generate customer complaints. These complaints can be grouped into the following three main categories:

The system is noisy.
Hot water service is unsatisfactory.
Space heating is unsatisfactory.

1. CAUSES OF 'NOISY SYSTEM'

- a. Noisy pump operation:
Check speed setting - if necessary, reduce pump speed.
Cavitation on account of insufficient static head on suction side (see System Design).
- b. Noisy boiler operation:
Check the water flow through the boiler by measuring the temperature differential across it whilst the boiler is on full gas rate. If the flow is unsatisfactory, contact the boiler manufacturer.
- c. Noisy when hot water tap is opened:
Water hammer - Loose pipework and/or tap washers.

2. CAUSES OF 'UNSATISFACTORY HOT WATER SERVICE'

- a. Check boiler thermostat - this should be set at maximum.
- b. Check that the boiler flow temperature is adequate.
- c. Check thermostatic mixing valve - if necessary, adjust to deliver hotter or cooler water as needed.
- d. Check that the space heating load is not greater than the boiler output.
- e. If a radiator is fitted across the primary flow and return for summer use, check that this is correctly connected (see Figure 11, Page 8).

If 'a' to 'e' are correct **THEN IT IS LIKELY THAT THE HEAT EXCHANGER PERFORMANCE IS IMPAIRED EITHER:**

i) **INTERNALLY** by hard water scale

or

ii) **EXTERNALLY** by contaminants such as flux residue etc.

Both problems can be resolved quite simply, see pages 23/24 for details, or refer to a reputable water treatment company such as BetzDearborn (Sentinel) - Tel: 0151 495 1861, or Fernox Tel: 01799 550 811.

3. CAUSES OF 'UNSATISFACTORY SPACE HEATING'

- a. Check boiler thermostat. This should be set at maximum.
- b. Check operation and setting of room thermostat.
- c. If some rooms are not being heated properly, then increase the pump speed and if necessary balance the system.
- d. If radiators get warm when heating is off, then install gravity check valve in the heating circuit.

4. OVERFLOW FROM FEED & EXPANSION CISTERN

- a. Check that the controlled level of the cistern is no higher than the swaged indentation. Adjust if necessary.
- b. If a replacement ball valve is required, this should be obtained only from Gledhill Water Storage Ltd.

PROBLEM SOLVING

BOILERMATE FAULT FINDING

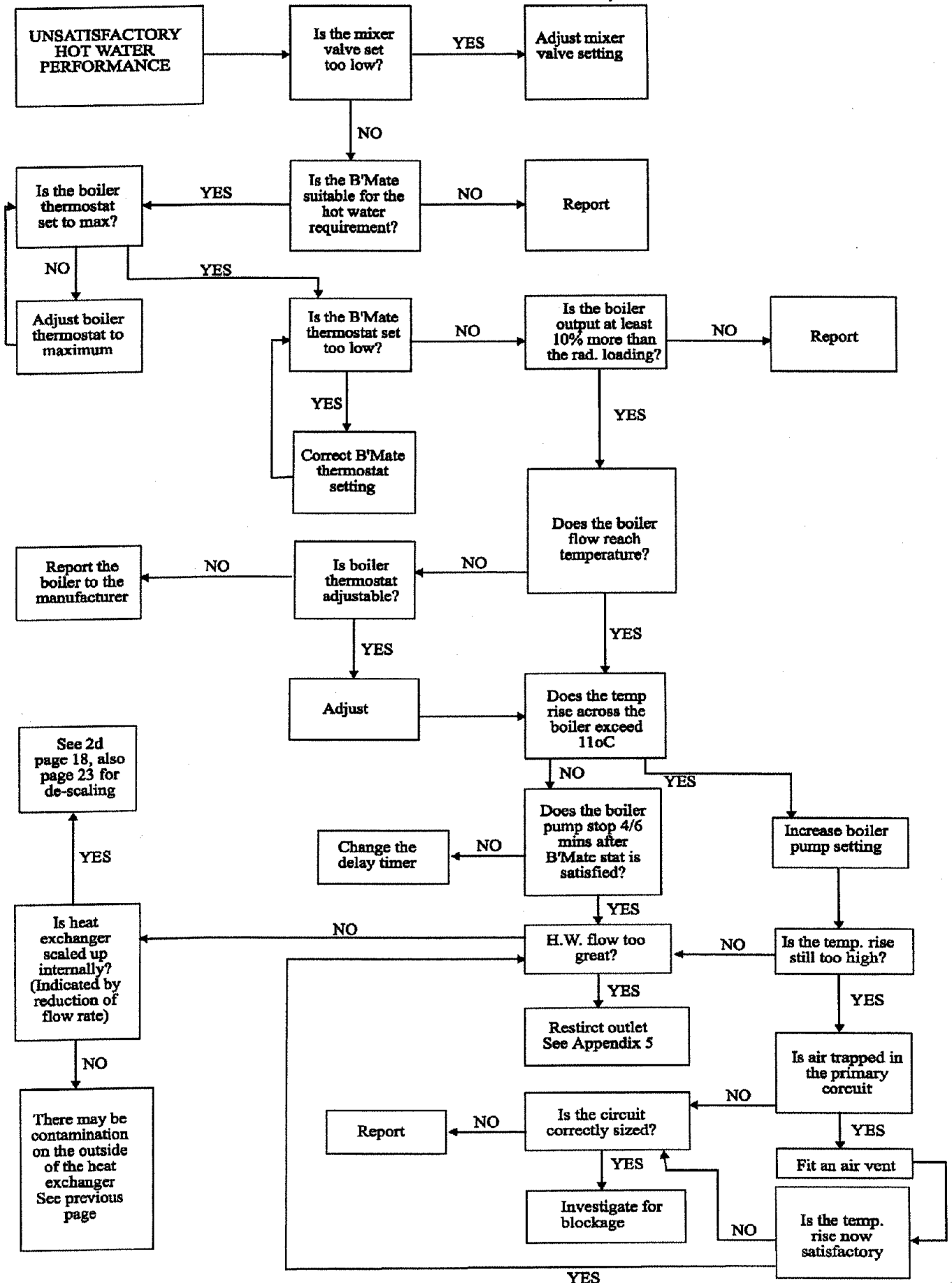

PROBLEM SOLVING

BOILERMATE FAULT FINDING

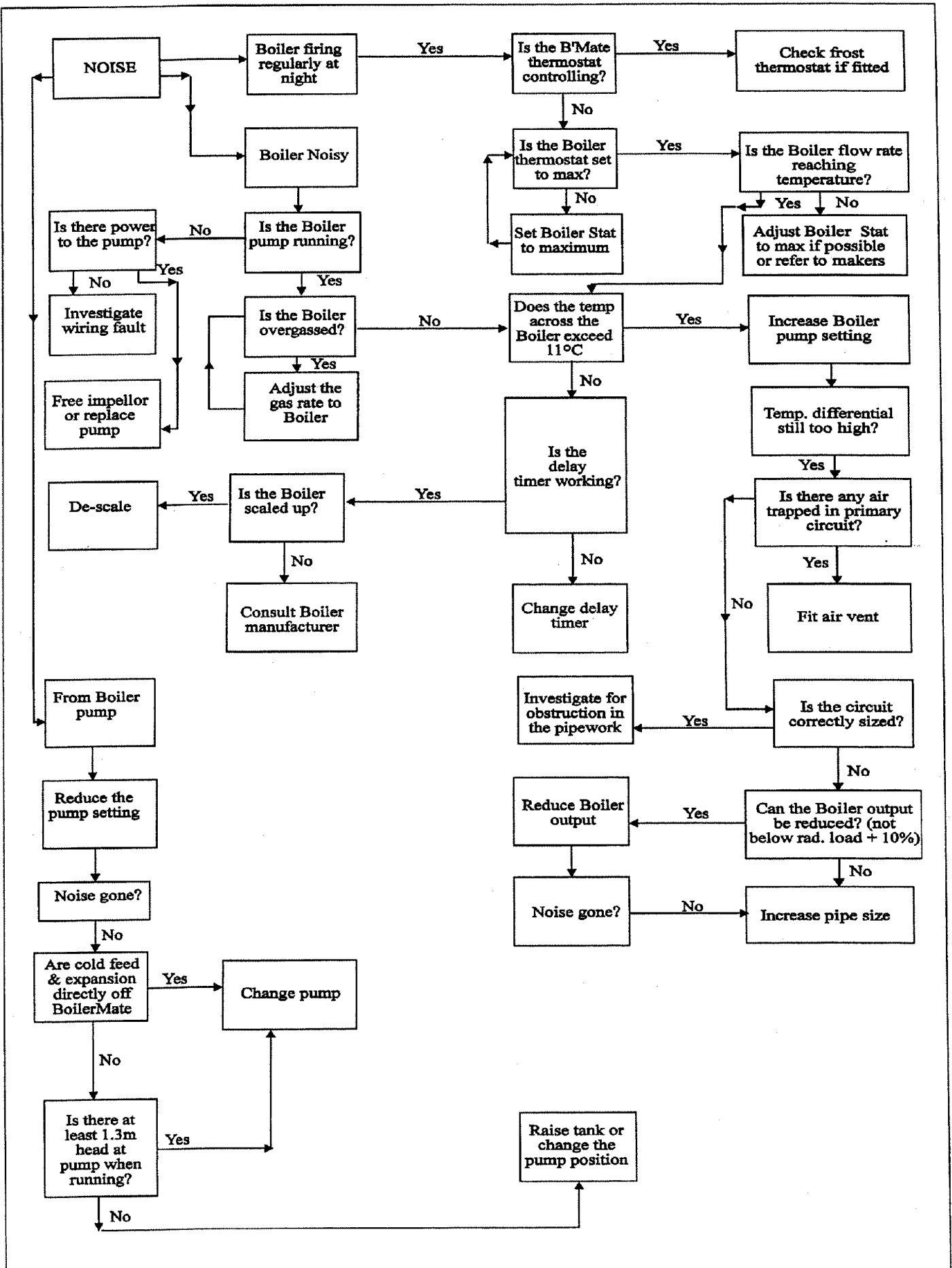

PROBLEM SOLVING

BOILERMATE FAULT FINDING

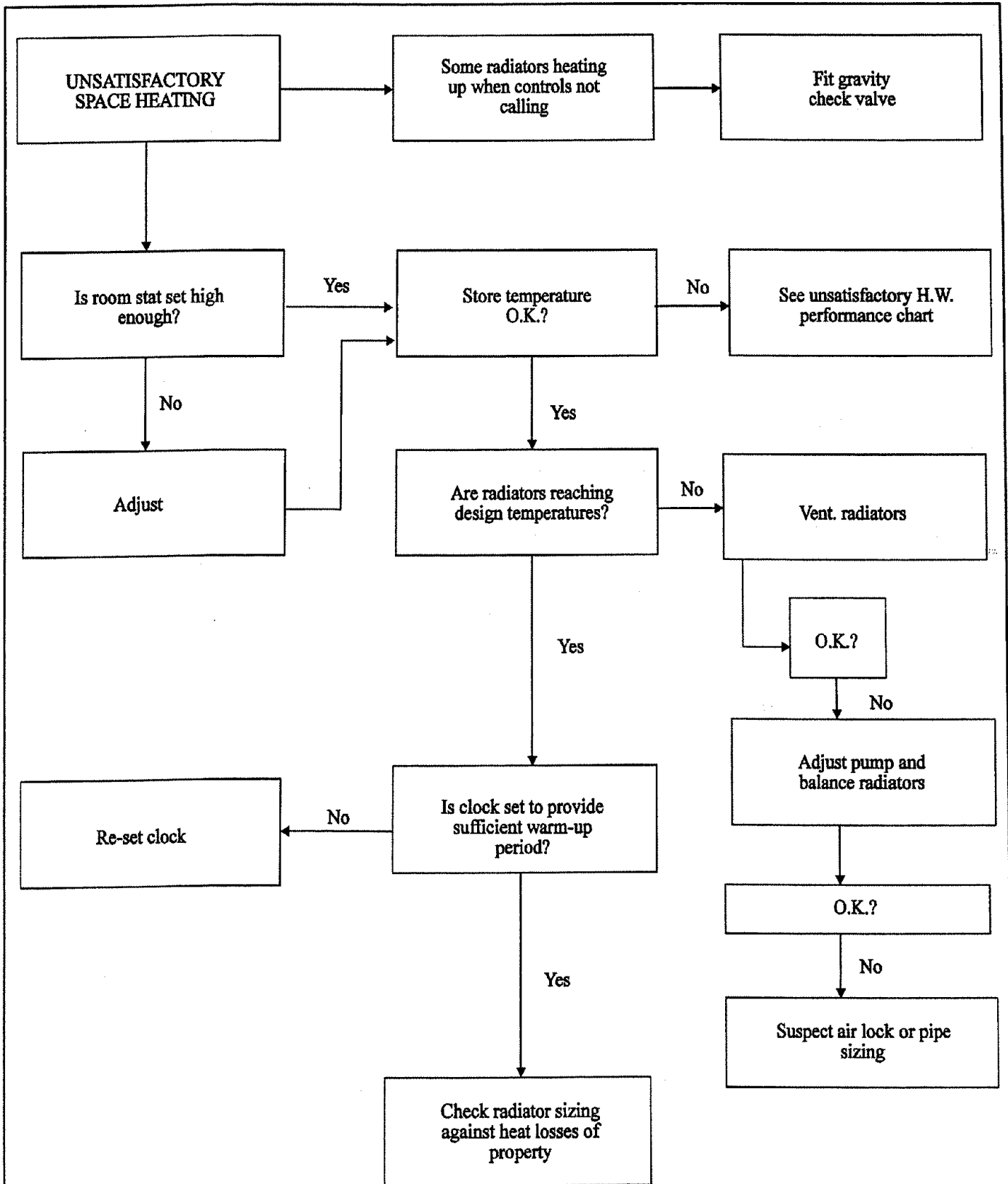

PROBLEM SOLVING

BOILERMATE ELECTRICAL FAULT FINDING CHART

For "QUICKFIX" see Appendix 4, Page 28

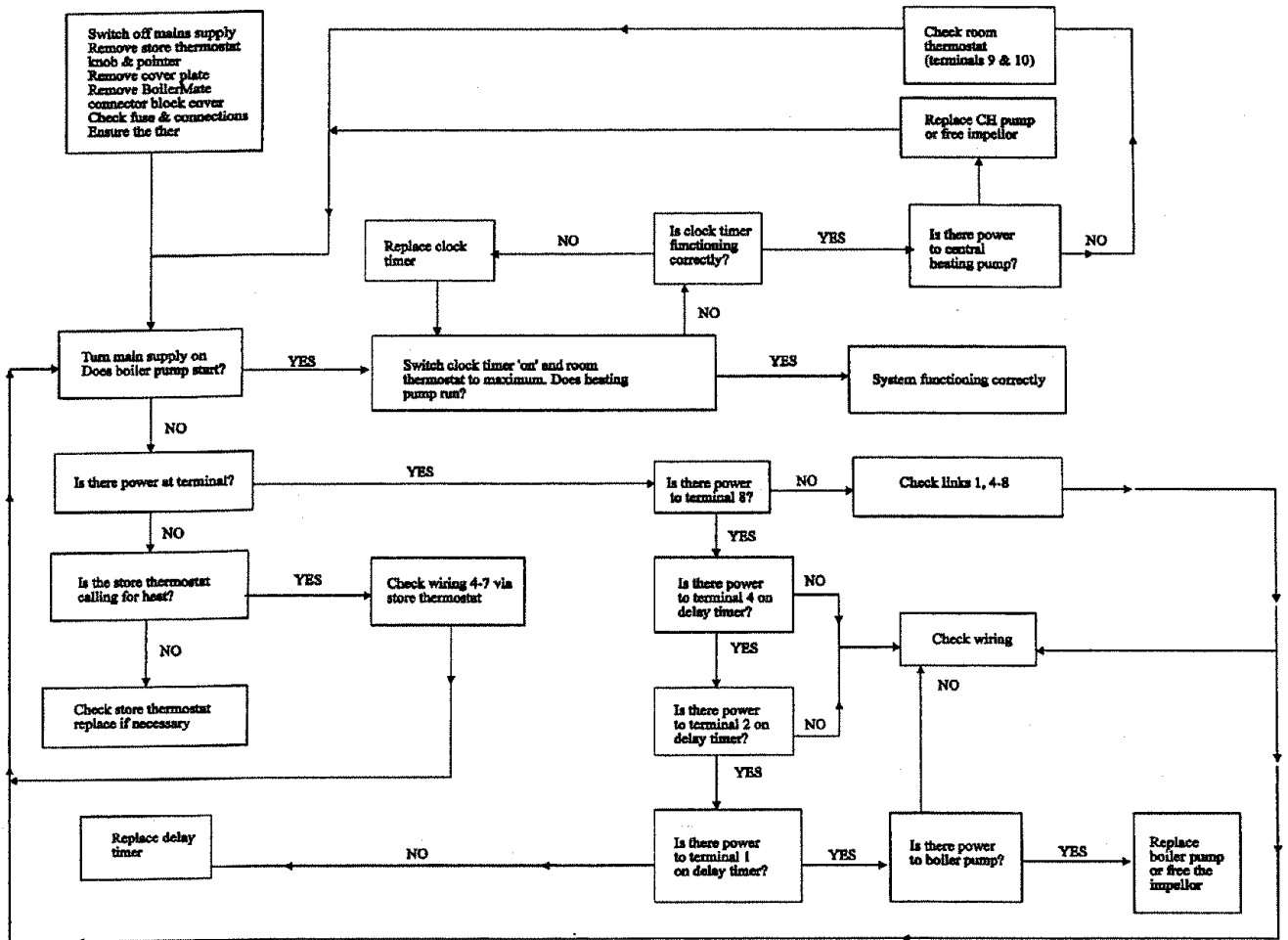

To test pump drive:-

Turn off the power to the system

Switch clock to permanent 'off'

Remove test link from pump drive P.C.B.

Turn on power (with clock still 'off')

Heating circuit pump will cycle on for 5 seconds, off at 10 second intervals.

Turn off power and replace test link

Turn on power and set clock as required

Note:

Failure of the pump drive will not affect the normal functioning of the pump under the control of the clock and the room thermostat.

Figure 18

PUMP DRIVE P.C.B.

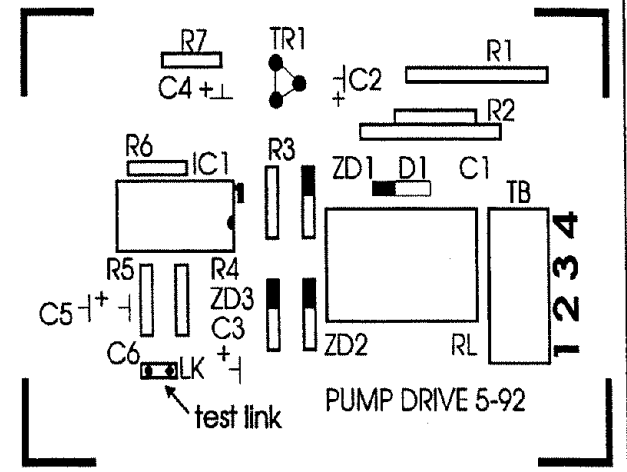

In situations where scale inhibitors have not been fitted and the hot water service has deteriorated a BoilerMate can be descaled very easily with equipment available from Gledhill.

You can now do the whole job easily and efficiently on site - and do it under the hour.

The operation is carried by a VORTEX DECALOMAT-3 Descaling Unit which removes the scale chemically. By simply replacing the thermostatic mixing valve on the hot water outlet with the special adaptor valve supplied, descaling solution is pumped through the secondary coil (see Figure 19). After approximately 45 minutes the job is done and the mixer valve is put back in place. The solution is made up of 2kg of either Sentinel ScaleCleen or Fernox DS-3 descaling powder dissolved in 20 litres of water (preferably warm but not exceeding 70°C). The powders are manufactured with a colour indicator which changes as the active ingredients are used up.

TO DE-SCALE BOILERMATE USING DECALOMAT-3

1. Before descaling turn the boiler off and run the hot water tap until the thermal store is below 40°C.
2. Turn off mains water supply at stop tap supplying the BoilerMate.
3. Open a hot tap on the hot water system.
4. Break the three unions securing the oventrop MV to the BoilerMate and remove the oventrop MV making sure a container is in place to collect spillage.

5. Attach the adaptor to the BoilerMate - two unions and washers.
6. Close all hot taps on the DHW system.

To charge Decalomat-3

7. Unscrew the large cap adjacent to the carrying handle.
8. Make sure that the hoses are connected together with the brass nipple.
9. Partly fill the Decalomat-3 with 20 litres of Sentinel ScaleCleen solution or Fernox DS-3 solution (the solution should be 2kg of powder dissolved in water).

NOTE: This solution is ACIDIC and MUST be handled with CARE. It is a wise precaution to do the mixing, filling and emptying outside the premises..

Observe the manufacturers handling instructions.

10. Replace the filling cap on the Decalomat-3.
 11. Break the joint between the hose (keeping both hoses above the level of the Decalomat-3) retaining the brass joining piece.
 12. Attach the hoses to the adaptor (ensure that the unions are finger tight on the 3/4" BSP male connectors to the adaptor).
 13. Loosen the filling cap on the Decalomat - 3 to allow carbon dioxide formed in the descaling process to escape.
 14. Plug in the Decalomat-3 to a 240V 50Hz electric supply.
- The pump in the Decalomat will now circulate the coloured descaling solution through the heat exchanger coil of the BoilerMate. Depending on the degree of scale formation within the coil, the following may be observed:

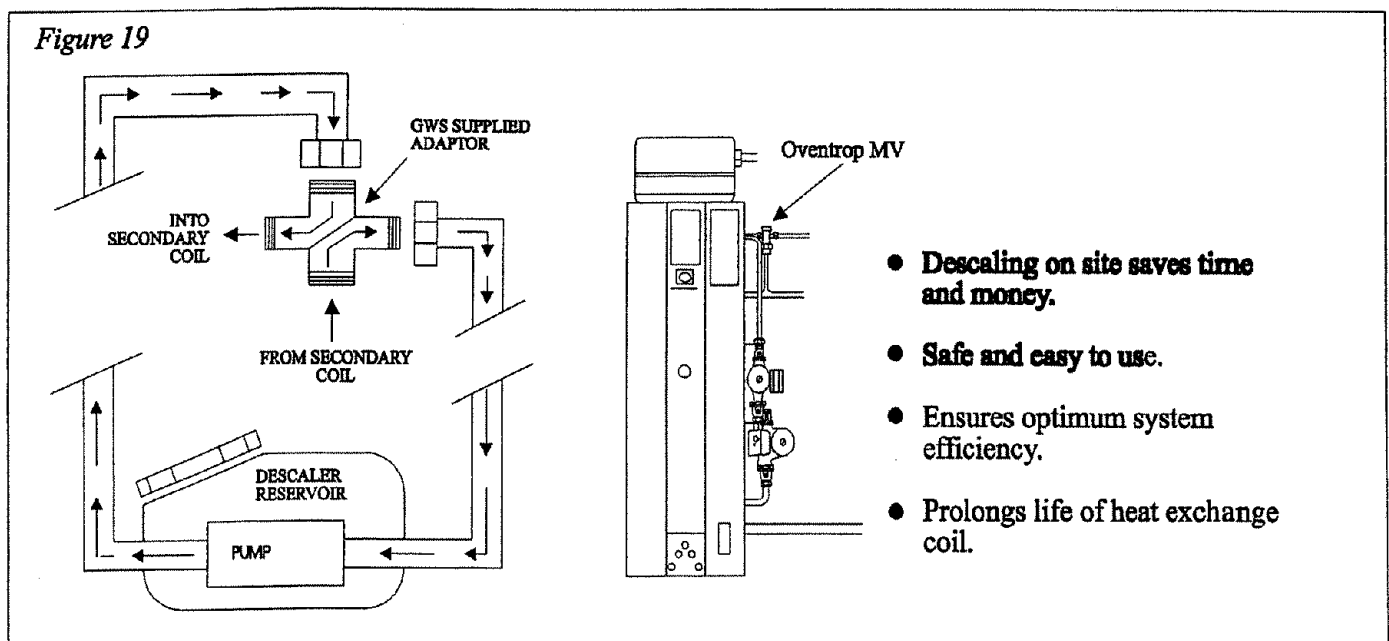

SERVICING

WITH SENTINEL SCALECLEEN

1. The red solution will be observed in one of the transparent plastic tubes, foam and an orange/yellow liquid may be seen in the other tube.
2. Flow of the red liquid may initially be intermittent due to:
 - a). Gas formation in the coil as the Sentinel ScaleClean attacks the scale.
 - b). Degree of blockage - this stage may exist for about half an hour.
3. Continuous flow will begin with the red Sentinel ScaleClean solution in one pipe and a foaming solution in the other.
4. If after some time, the colour in both pipes has turned to yellow (no gas bubbles are observed), the Sentinel ScaleClean is now exhausted and requires changing.
5. When the solution in both tubes remains red or orange and no gas bubbles are observed, the coil has been descaled.

WITH FERNOX DS-3

1. The yellow solution will be observed in one of the transparent plastic tubes, foam and a greenish blue liquid may be seen in the other tube.
2. Flow of the yellow liquid may initially be intermittent due to:
 - a). Gas formation in the coil as the Fernox DS-3 attacks the scale.
 - b). Degree of blockage - this stage may exist for about half an hour.
3. Continuous flow will begin with the yellow Fernox DS-3 solution in one pipe and a foaming solution in the other.
4. If after some time, the colour in both pipes has turned to green (no gas bubbles are observed), the Fernox DS-3 is now exhausted and requires changing.
5. When the solution in both tubes is still yellow and no gas bubbles are observed, the coil has been descaled.

TO REMOVE DECALOMAT-3

1. Unplug Decalomat - 3 from electrical supply.
2. Tighten the filling cap on the Decalomat - 3.
3. Remove the two hoses from the adaptor.
4. Join hoses with brass connector piece.
5. Remove adaptor.
6. Replace Oventrop mixing valve - **ensuring that it is the correct way round.**
7. Open a hot tap - preferably to a porcelain sink.
8. Turn on the mains water supply to BoilerMate.
9. Allow the system to flush via the open hot tap for some minutes, then flush out system at each hot tap.

APPENDIX 1

REMOTE FIXING OF THE GRASSLIN DIGITAL PROGRAMMED TIMER OR THE ELECTRO-MECHANICAL CLOCK/TIMER.

A Remote Fixing Kit is available for this purpose, consisting of:

1. Backplate - complete with terminal strip.
2. Clock cover (surface mounting) complete with 2 No. retaining screws.
3. Terminal strip cover.
4. Opaque dust cover.

Procedure

(This work must be carried out by a qualified person)

First switch off the power to the BoilerMate. Remove the transparent dust cover from the clock. Remove the flush mounted clock by turning the two plastic screws 1/4 turn anti-clockwise. The clock may now be withdrawn. Remove the spade connectors from the clock terminals.

Remove the clock wires from the main terminal strip of the BoilerMate. These are from terminals 1, 2 and 9 and are shown as broken lines on the wiring diagram.

Mount the backplate in the required remote position, using 3 No. 6 gauge round head screws.

Connect the backplate to the main BoilerMate terminal. Refer to the wiring diagram. Do not forget to link terminals 1 and 3 of the backplate.

Remove the clock module from its flush mounting casing. This casing, together with the opaque dust cover can now be used to blank off the hole in the BoilerMate front panel.

Mount the clock module onto the backplate, using the two locating pins. Press the clock home to engage its terminals into the terminal block.

Slide the terminal strip cover into position. (Note that knock-outs are provided for surface wiring).

Fit the clock cover (surface mounting) and secure with the two screws provided.

Switch on the power and check out. Programme the clock to required heating cycle. Fit transparent dust cover.

Figure 20

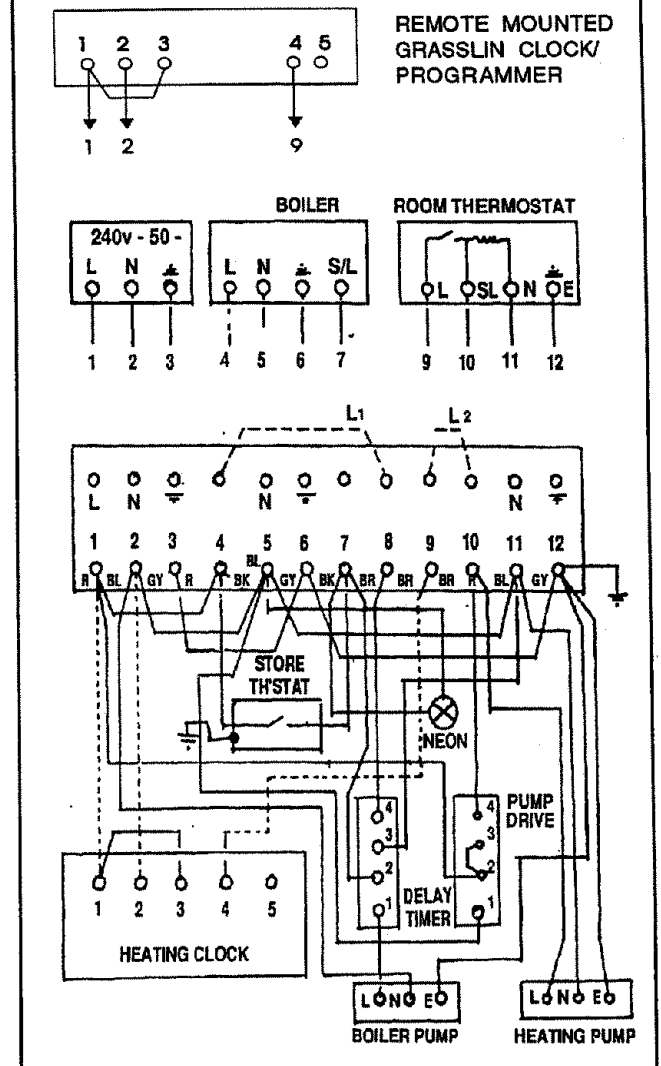

Boiler permanent live is not usually required, unless needed for some purpose other than for a pump over-run.

APPENDIX 2

OVERNIGHT SHUTDOWN

The most effective service from a thermal storage system is when the boiler is on demand for twenty four hours. In special circumstances the system can be wired to isolate the boiler overnight by reference Figure 21.

Figure 21

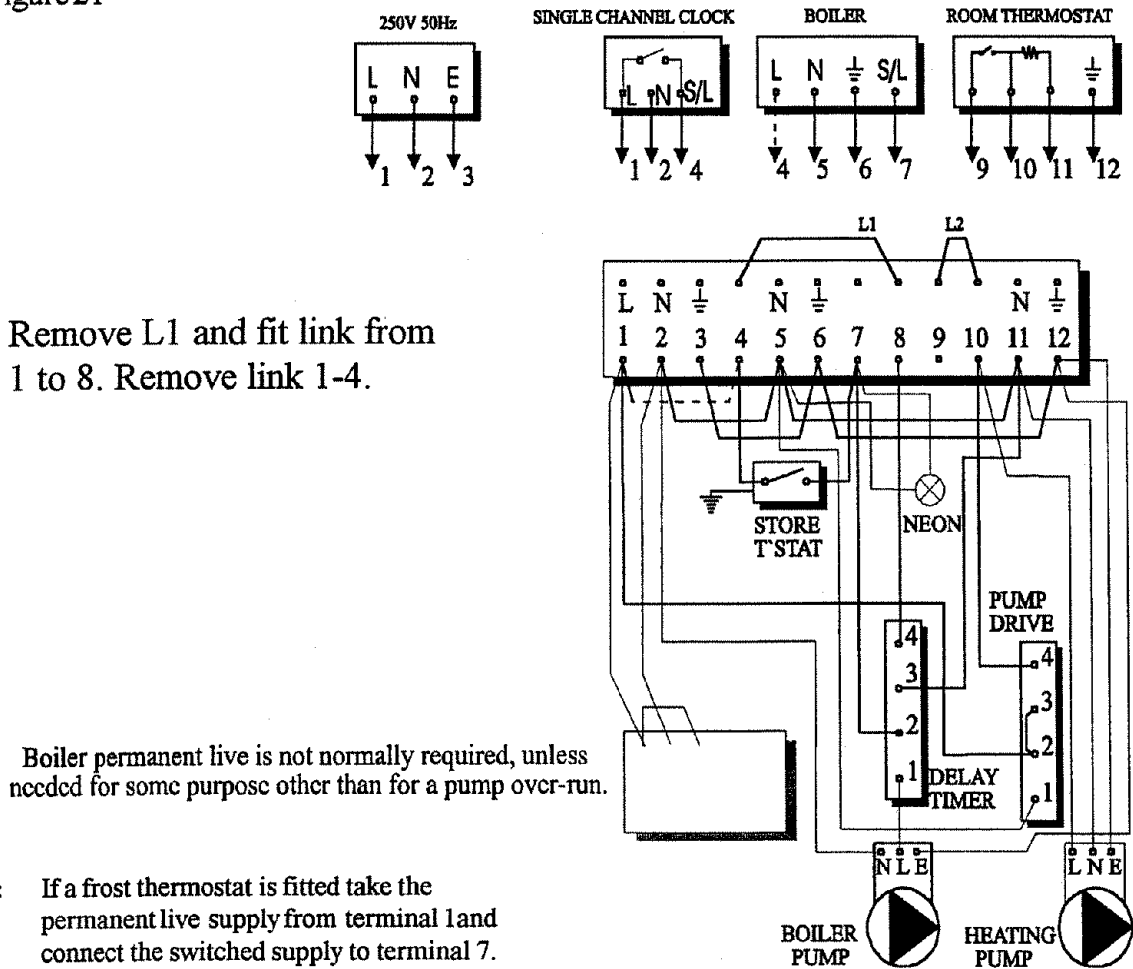

REMOTE PROGRAMMER

If the BoilerMate is supplied as a no clock option the remote programmer/clock should be wired as follows:-

BOILERMATE WITH A REMOTE 2-CHANNEL PROGRAMMER

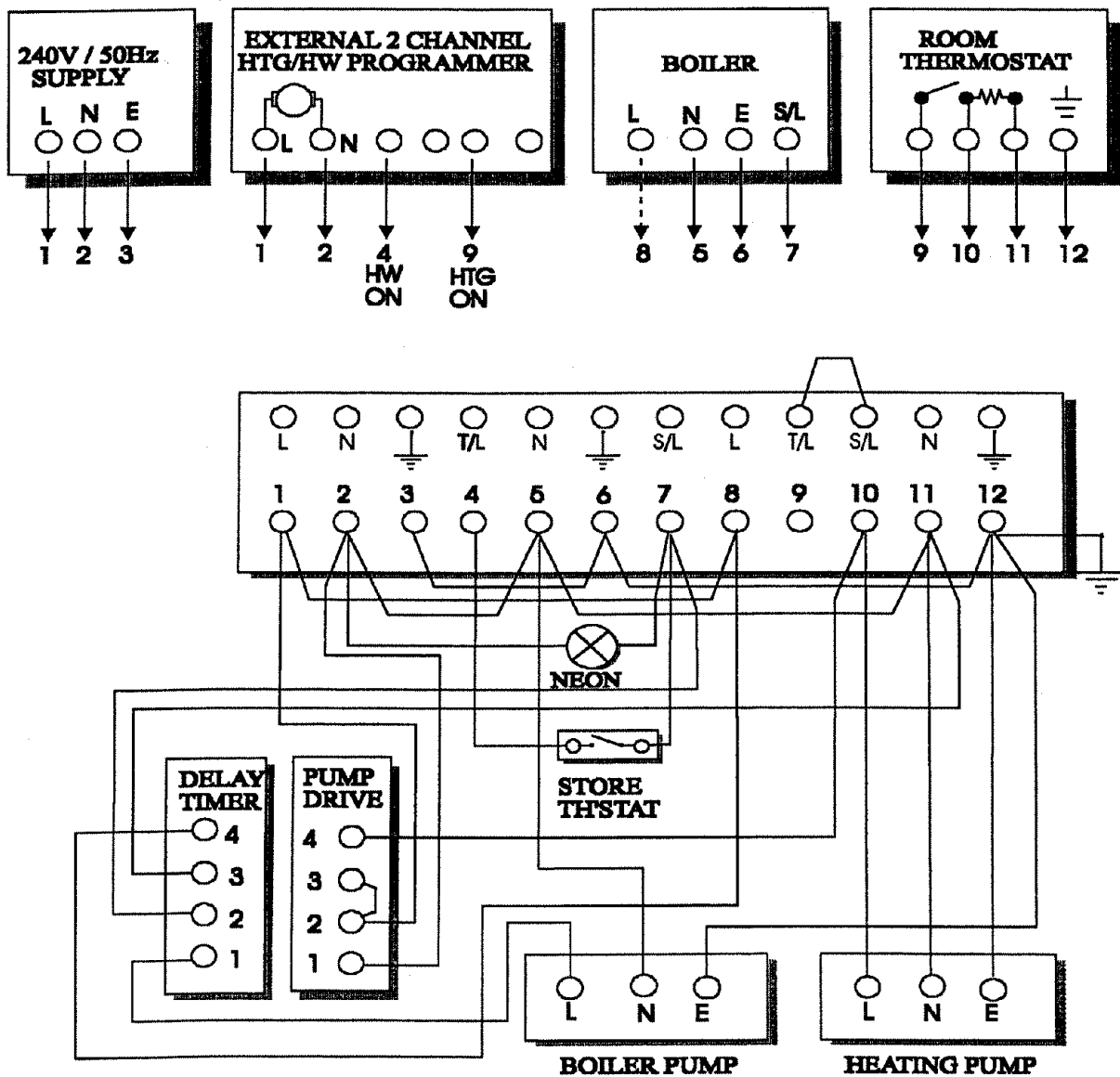

NOTES:

- 1) The connection from 8 to boiler L is not normally required unless the boiler requires a permanent live for some purpose *other than* for a pump over-run.
- 2) Remove the link 9-10 if a room thermostat is to be fitted.

APPENDIX 3

MAXOL BOILER CONNECTIONS

Figure 22

MAXOL 600 OR MOROCCO

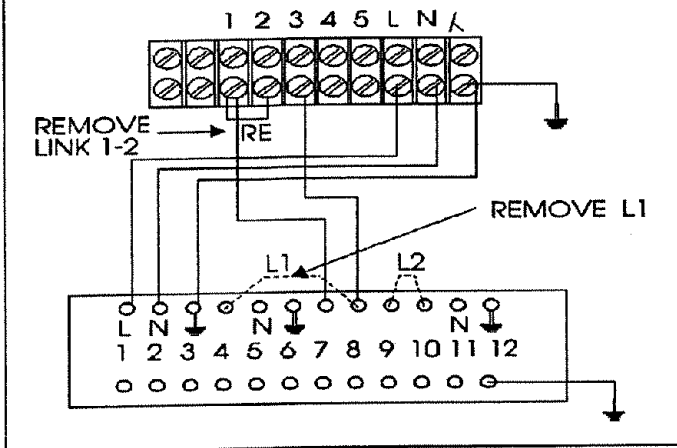
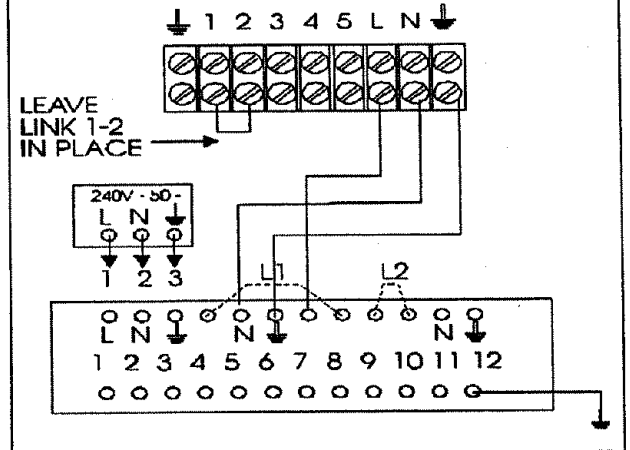
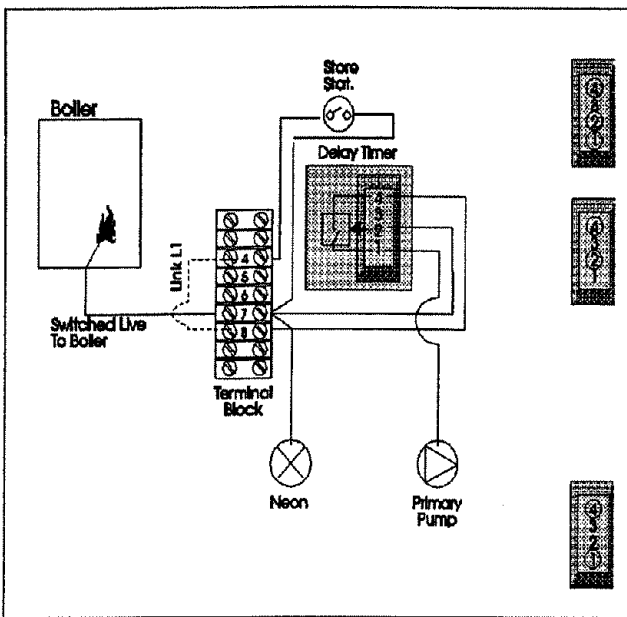

Figure 23

MAXOL MICRO TURBO 40



BOILERMATE PRIMARY CIRCUIT CONTROL



BOILERMATE HEATING PUMP CIRCUIT

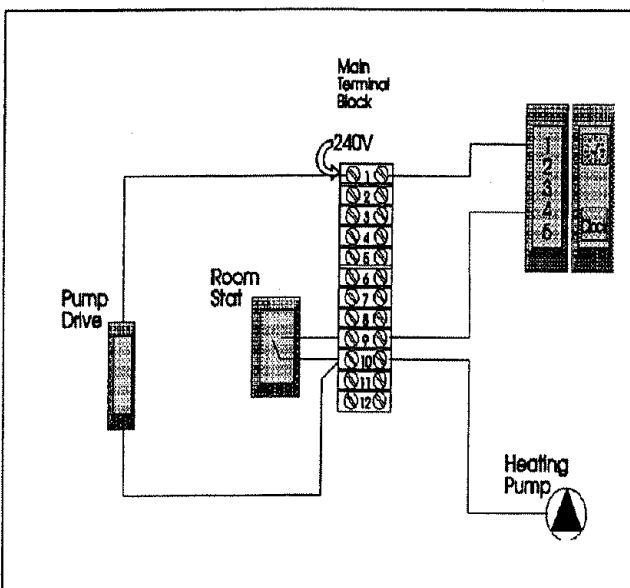

TO TEST THE PUMP DRIVE:-

TURN OFF THE POWER TO THE SYSTEM.
 SWITCH CLOCK TO PERMANENT 'OFF'.
 REMOVE TEST LINK FROM PUMP DRIVE P.C.B.
 TURN ON POWER (WITH CLOCK STILL 'OFF').
 HEATING CIRCUIT PUMP WILL CYCLE AT 10 SECOND INTERVALS.
 TURN OFF POWER AND REPLACE TEST LINK.
 TURN ON POWER AND SET CLOCK AS REQUIRED.

NOTE:

FAILURE OF THE PUMP DRIVE WILL NOT AFFECT THE NORMAL FUNCTIONING OF THE PUMP UNDER THE CONTROL OF THE CLOCK AND THE ROOM THERMOSTAT.

PRIMARY PUMP NOT RUNNING

IF TERMINALS 1, 2, 4 ARE LIVE THE PUMP NEEDS CHECKING.

IF TERMINALS 2 AND 4 ARE LIVE THEN THE DELAY TIMER IS FAULTY AND NEEDS CHANGING.

QUICKFIX

IF YOU HAVE NO SPARE TEMPORARILY LINK 1 AND 4.

PRIMARY PUMP RUNS CONTINUOUSLY (NEON EXTINGUISHED)

IF TERMINALS 1 AND 4 ARE LIVE AND THE PUMP CONTINUES TO RUN EVEN THOUGH POWER HAS BEEN OFF, ON 2, FOR MORE THAN 5 MINUTES:

DELAY TIMER FAULTY

HEATING PUMP WILL NOT RUN

CHECK LIVE IN AT TERMINAL 1.
 CHECK ROOMSTAT AND CLOCK ARE ON.

1. IS 9 LIVE?

DIAGNOSIS

IF NOT, THEN CLOCK IS FAULTY.

QUICKFIX

LINK TERMINALS 1 AND 9 AND USE ROOM STAT TO TURN HEATING ON AND OFF.

2. IS 10 DEAD? (AND 9 LIVE)

DIAGNOSIS

ROOM STAT IS FAULTY.

QUICKFIX

LINK 9 AND 10 AND USE CLOCK TO CONTROL THE HEATING.

3. IS 10 LIVE?

DIAGNOSIS

NEED TO REPLACE THE HEATING PUMP.

APPENDIX 5

WATER SAVINGS

WATER RELATED COSTS CAN BE REDUCED BY GOOD PLUMBING PRACTICE.

TAPS & MIXERS

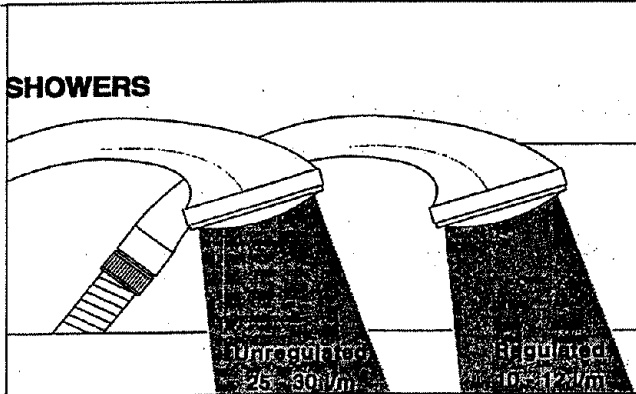
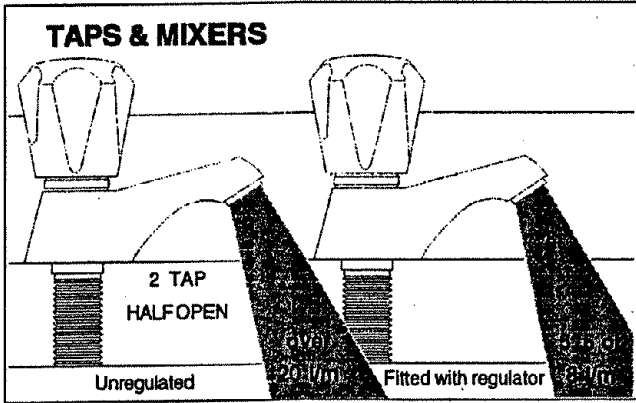

Vast quantities of water are needlessly run off to waste due to Taps, Mixers and Showers discharging flow rates far in excess of the rates required for them to perform their duties.

The contrasting flow rates shown on this leaflet clearly illustrate the savings that can be made whilst still providing a good performance.

British made AQUAFLOW REGULATORS provide constant flow rates by automatically compensating for supply pressure changes between 1 bar & 10 bars.

To facilitate installation into the wide range of plumbing equipment which is encountered in the U.K, FOUR FIXING OPTIONS are available:-

OPTIONS FOR SHOWERS

1. MXF "DW" RANGE - For fitting behind Fixed Shower Heads or onto Flexible Hoses for Handshowers (preferably onto the inlet end when lightweight hoses are used).
2. COMPRESSION FITTING RANGE. "In Line" regulators as in Option 4 for Taps & Mixers.

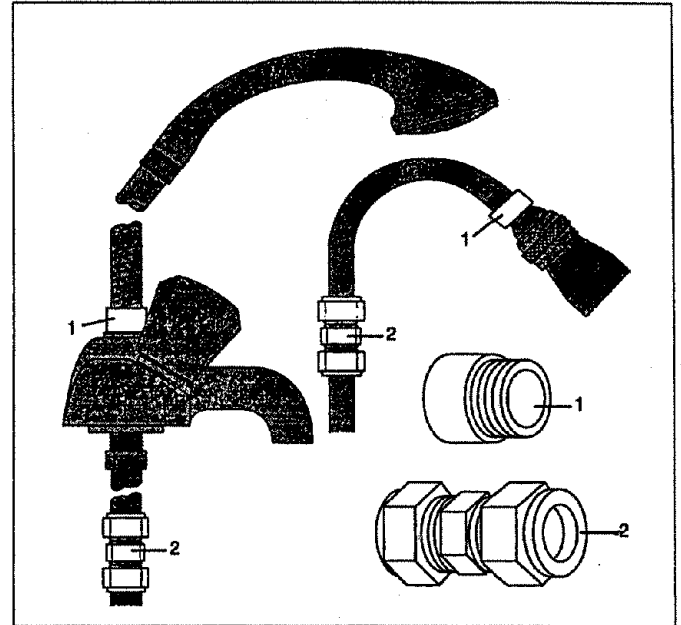

4 FIXING OPTIONS FOR TAPS & MIXERS

1. MK RANGE - Combined Regulators & Aerator for screwing onto Taps & Mixers with internal or external threads on their noses. Anti Vandal models also available.
2. MR05-T RANGE - Internal Regulators. Push fit into Tap or Mixer seats. Produced in three sizes - 12.5mm (BS1010), 12mm & 10mm, Flangeless models also available for Taps with Low Lift washers.
3. MXF STANDARD RANGE - Screw on tail models for Taps & Mixers. Fix onto the tails before fitting the tap connectors. Available in 3/8", 1/2", 3/4" and 1" BSP.
4. COMPRESSION FITTING RANGE - "In Line" regulators housed in 15mm & 22mm CXC COUPLERS & ISOLATING VALVES. " " UK WFBs LISTED BY THE WATER RESEARCH CENTRE. Isolation valves available for slotted screwdriver operation or with coloured plastic handles. Now available also in plastic bodied push-fit couplers & valves.

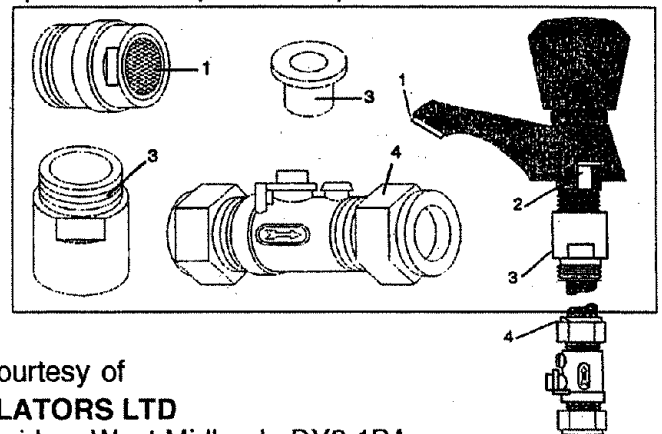

Information by courtesy of
AQUAFLOW REGULATORS LTD
 Haywood House, 40 New Road, Stourbridge, West Midlands DY8 1PA
 Telephone (01384) 442611 Fax: (01384) 442612

PERFORMANCE SPECIFICATION

BOILERMATE / / PERFORMANCE WHEN TESTED IN ACCORDANCE WITH THE BRITISH GAS SPECIFICATION FOR DIRECT INTEGRATED THERMAL STORES

These tests are carried out at flow rates of 18 litres/minute and 30 litres/minute but certain units have outputs that fall between these criteria, these are shown below as SC2+ and represent the same temperature rise at an enhanced flow rate.

	120 115	140 125	180	200	220
CLASSIFICATION	SC2	SC2+	SC2+	SC2+	SC3
MAXIMUM RECOMMENDED RADIATOR CAPACITY (kW)	9	9	17	20	26
OPTIMUM RECOMMENDED BOILER SIZE (kW)	14.6	14.6	20.5	23.4	29.3
NOMINAL FLOW RATE (LITRES/MIN)	18	22	25	27	30
HEAT EXCHANGER RATING AT NOMINAL FLOW RATE	56.3	56.9	64.8	67.1	92.4
MAXIMUM SECONDARY WORKING PRESSURE	3.5	3.5	3.5	3.5	3.5
MAXIMUM PRIMARY HEAD	6M	6M	6M	6M	6M

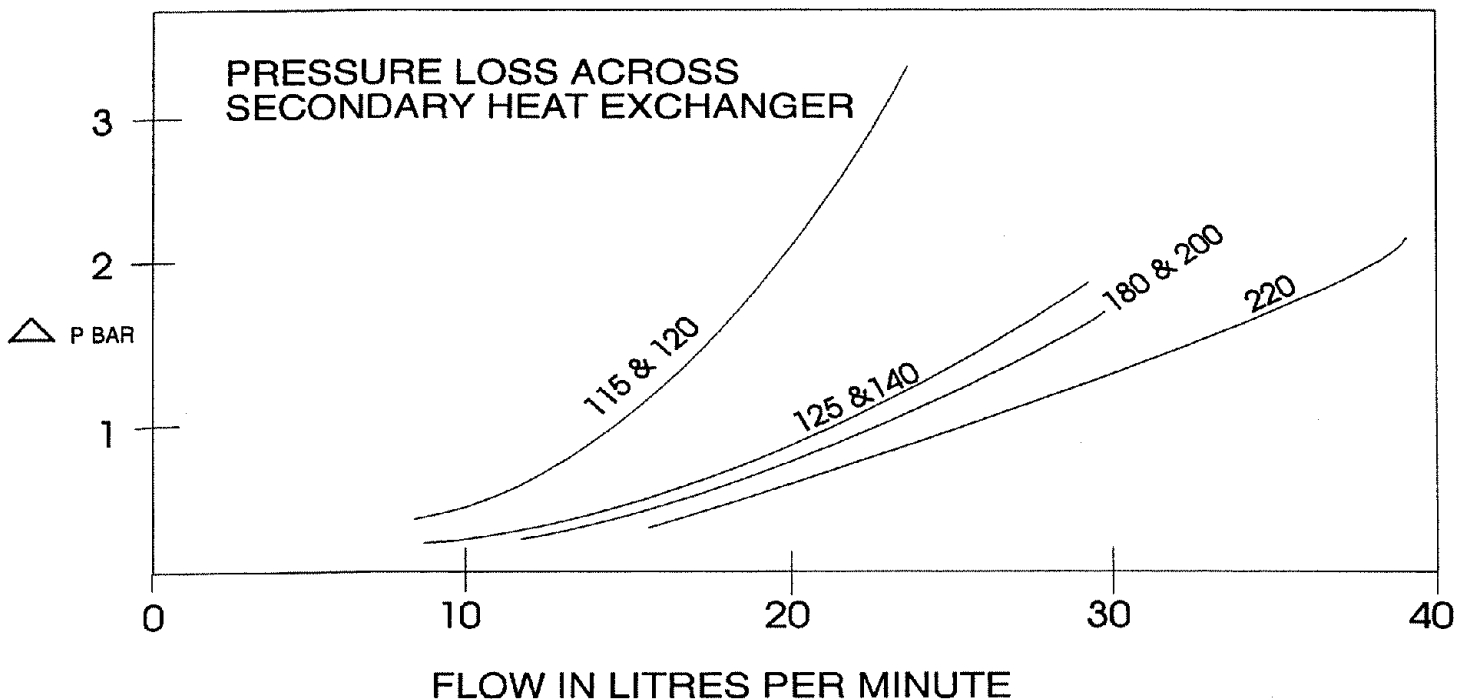

PERFORMANCE SPECIFICATION

DRAW-OFF PROFILES AT 18 LITRES/MINUTE *

WITHOUT MIXER VALVE _____

MIXER VALVE SET TO 55 C.....

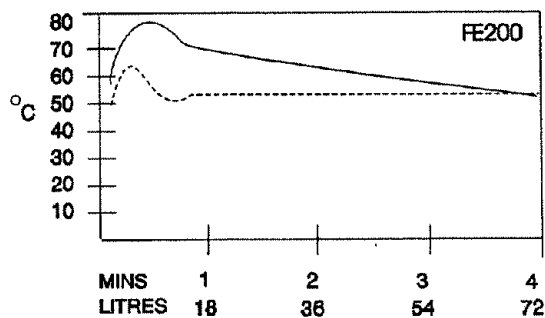
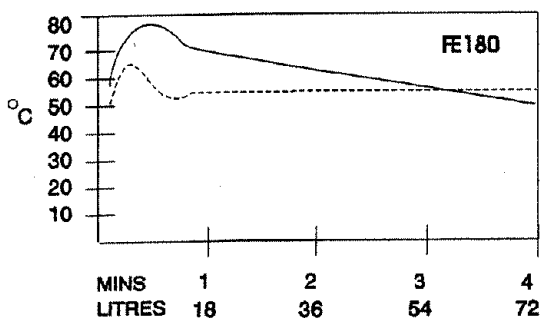
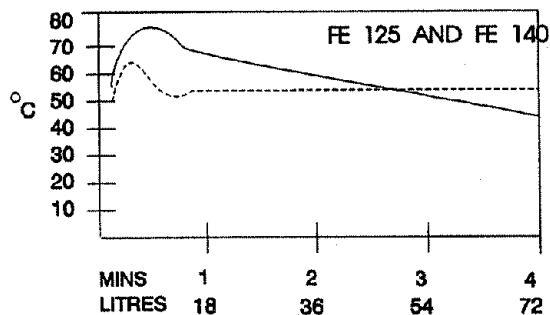
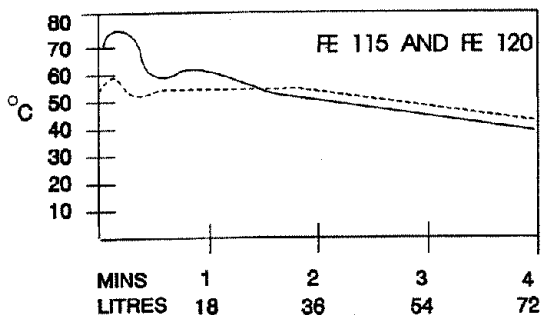

DRAW-OFF PROFILE AT 30 LITRES/MINUTE *

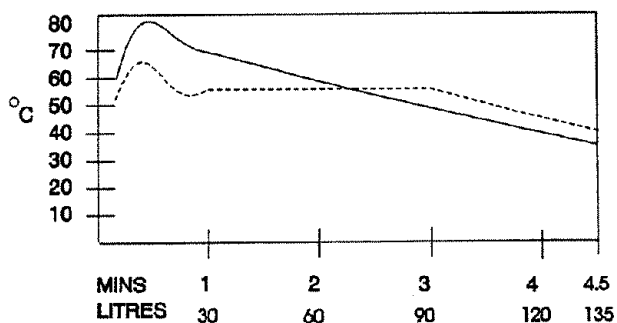

* As specified by the British Gas Performance Specification for Integrated Thermal Stores for Heating and Hot Water and Buffer Stores

Position of Data Badge: Front - Bottom

Key No.	G.C. Part No.		Number Off	Maker's Part No.
1	370 505	Ballvalve to BS 1212 Pt 2	1	FT 207
2	370 506	Ballvalve Float	1	FT 429
3	385 872	Water Mixing Valve - Brawa	1	XC 007
4	370 507	3/4" Spare Ring Gasket 3 Per Set - For Mixing Valve	1	XC 008
5	384 288	Pump - Grundfos UPS 15/50 130mm	1	XB001
6	370 508	22mm Pump Gate Valve - Special	1	XB 002
7	370 509	28mm Pump Gate Valve - Special	1	XB 032
9	370 502	Pump Delay Timer Printed Circuit Board	1	XB 041
12	385 873	Electro-Mechanical Heating Time Clock - Grasslin MIL72ESTUZH	1	XB 215
13	385 874	Digital Heating Time Clock - Grasslin MIL72EDIGI12	1	XB 216
14	370 510	Wall Mounting Clock Conversion Kit Grasslin	1	XB 217
16	370 512	White Polypropalene F & E Tank Cover	1	XB 069
17	370 513	Green Neon "Calling for Heat" Indicator	1	XB 100
19	370 515	Terminal Block Insulating Cover	1	XB 030
20	370 516	Pump Drive P.C.B.	1	XB 104
21	370 517	Hawco Capillary Thermostat	1	XB 117
22	370 518	Hawco Thermostat Knob	1	XB 118
LITERATURE				
23	370 519	Installation Instructions	1	XB 119

Gledhill (Water Storage) Ltd

AMD, MAY 2006

CONDITIONS OF SALE & WARRANTY TERMS

1. We only do business upon the Conditions which appear below and no other. Unless we so agree in writing these Conditions shall apply in full to any supply of goods by us to the exclusion of any Conditions or terms sought to be imposed by any purchaser. These Conditions of Sale and Warranty Terms override those which are contained on the Invoice Forms and all Sales are now subject to these Conditions of Sale and Warranty terms only.

2. PRICE

Once an order or call off has been accepted the price will be held for three months but if delivery is extended beyond that period at the customer's request, then we reserve the right to amend the price when necessary. The company reviews its pricing annually to adjust for changes in our cost base. We reserve the right to alter prices at any time for severe movements in raw materials (mainly copper and steel). If there is to be a change we will give customers at least thirteen weeks notice but anything delivered after that date will be at the revised price. An order may not be cancelled or varied after acceptance without the written consent of the company. Such cancellation or variation shall be subject to such reasonable charges as may be appropriate.

3. SPECIFICATION

The goods are supplied in accordance with the Specifications (if any) submitted to the Purchaser and any additions and alterations shall be the subject of an extra charge. Any goods not so specified shall be in accordance with our printed literature or the literature of any of our component suppliers (subject to any modifications made since publication). If we adopt any changes in construction or design of the goods, or in the specification printed in our literature, the Purchaser shall accept the goods so changed in fulfilment of the order.

4. PAYMENT

The invoice price of goods shall be payable within 30 days of despatch by us of our invoice for the goods or such longer time as may be stated by our quotation or invoice. If we receive payment in full on or before the due date we will allow an appropriate settlement discount except where we have quoted a special net price. If payment is not received in full on or before the due date we shall be entitled in addition to the invoice price to:

- (i) payment of a sum equal to any increase in the copper price supplement applicable to the particular goods sold between the date of receipt of order and the date of receipt of payment in full; and
- (ii) interest on any part of the invoice price unpaid after the due date at the rate of 3% per annum over the base rate for the time being of HSBC Bank plc.

5. TIME

We give estimates of delivery dates in good faith and time of delivery is not nor shall be made of the essence of any contract nor shall we be liable for any loss or damage occasioned by delay in delivery.

6. DELIVERY

We deliver free normally by our own vehicles within 25 miles of any of our manufacturing depots. Delivery to any place more than 25 miles from one of our manufacturing depots is subject to our quoted delivery charges. We reserve the right to make delivery of goods contained in one order by more than one consignment and at different times. Where a period is agreed for delivery and such period is not extended by our Agreement, the Purchaser shall take delivery within that period. If the Purchaser fails to take delivery, we shall be entitled at the Purchaser's risk and expense to store the goods at the Purchaser's premises or elsewhere and to demand payment as if they had been despatched. Off loading at point of delivery shall be the responsibility of and be undertaken by the Purchaser.

7. SHORTAGES OR DAMAGE

Goods must be inspected before signature of delivery note and any damage, shortage or discrepancy noted on the delivery note and the goods returned on the same vehicle. The buyer must also give us immediate written notice of the damage, shortage or discrepancy so that we may prompt investigation.

8. RETURN OF GOODS

Goods may not be returned to the Company except by prior written permission of an authorised officer of the Company and such return shall be subject to payment by the Purchaser of handling and re-stocking charges, transport and all other costs incurred by the Company.

9. COMPANY LIABILITY

All our goods are made of the best materials from reputable manufacturers and where stated are manufactured to the appropriate British Standard. Complaints must be given to us immediately, before any action is taken, as responsibility cannot be accepted if repairs or renewals are attempted on site without our written authority.

Defects caused by corrosion or scale deposits are not covered by this guarantee save as expressly provided in paragraph (4) of this Condition 9.

Where we agree to rectify any defect, we reserve the right to undertake the work on our own premises.

The following guarantee covers faulty materials and manufacture for the stated period, **provided that:-**

- The unit has been installed in accordance with our installation and service instructions and all relevant codes of practice and regulations in force at the time of installation.
- That all necessary Inlet controls and safety valves have been fitted correctly.
- It has only been used for the storage of potable water supplied from the public mains.
- Where appropriate the unit has been regularly maintained as detailed in the installation and service instructions.

(1) **Domestic and Commercial Open Vented Cylinders and Tanks.**

If the copper cylinder or tank or any integral pipework proves to be defective either in materials or workmanship, we will either repair or supply replacement at our option with the closest substitute in the case of any obsolete product to any address in Great Britain.

- (a) free of all charge during the first year after delivery by us.
- (b) thereafter at a charge of one-tenth of the then current list price and any copper price supplement and delivery charge during the second year after delivery by us and increasing by a further one-tenth on the second and subsequent anniversary of delivery by us.

AND FURTHER we will meet the contractors/installers reasonable costs in removing and replacing any defective Open Vented Copper Cylinder or Tank with defective integral pipework as follows:

(i) in the case of vessels of less than 80 imperial gallons capacity up to a maximum of one-half of the extent of our liability in regard to the replacement product expressed in (1) (a) and (b) above

ii) in the case of vessels larger than 79 imperial gallons capacity up to a maximum of one-quarter of the extent of our liability in regard to the replacement product as expressed in paragraphs (1) (a) and (b) above.

(2) **Domestic Mains Fed Products**

If the copper storage vessel itself or any integral pipework as part of the storage vessel assembly proves to be defective either in materials or workmanship, we reserve the right to either repair or supply replacements or the closest possible substitute in the case of any obsolete product and will collect and deliver to any address in England, Wales and Scotland (excluding all Scottish Islands).

(a) free of all charge during the first year after delivery by us.

(b) thereafter at a charge of one-fifth of the then current list price or any copper price supplement and delivery charge during the second year after delivery by us increasing by a further one-fifth on the second and subsequent anniversary of delivery by us.

AND FURTHER we will meet the contractors/installers reasonable costs in removing and replacing any defective copper storage vessel or storage vessel with defective integral pipework from the Domestic Mains Pressure Range of products up to a maximum of one-third of the extent of our liability in regard to the replacement product expressed in (2) (a) and (b) above.

(3) **Integrated Boiler and Storage Vessel Products and Stand Alone Boilers**

In the case of the GulfStream range of products and the Gledhill boiler range of products, Gledhill guarantees the heat exchanger (boiler) for material and construction faults for two years and FURTHER we will meet the installer/contractors reasonable costs in removing and replacing any DEFECTIVE heat exchanger up to a MAXIMUM of one third of the extent of our liability in regard to the replacement product.

THE RESPONSIBILITY FOR THE EXECUTION OF THIS GUARANTEE LIES WITH THE INSTALLER.

The guarantee becomes null and void if the appliance is used incorrectly, or in the event of proven negligence or incorrectly implemented repairs **OR FAILURE TO CARRY OUT THE RECOMMENDED INSPECTION/MAINTENANCE.** The guarantee also becomes null and void if changes are made to the appliance without our knowledge, or if the serial number on the appliance is removed or made illegible.

The annual service must be carried out by a competent installer in accordance with the advice given by Gledhill and using Gledhill approved parts.

(4) **Components of our products other than Storage Vessels and Integral Pipework.**

We will either extend to the purchaser the same terms of warranty as we are given by the manufacturer of the component or if the manufacturer does not give any warranty, replace free of charge any component which becomes defective within twelve months after the date of the delivery by us and is returned to us at the purchaser's expense but we shall not meet the cost of removal or shipping or return of the component or any other cost charges or damages incurred by the purchaser.

If the appliance manufactured by Gledhill incorporates a factory fitted scale inhibitor then during the period of three years from the date of delivery Gledhill will replace, free of charge, any plate heat exchanger fitted in the appliance as original equipment in which scale formation occurs that materially reduces the effectiveness of the plate heat exchanger. This guarantee does not extend to any other component installed within the Gledhill appliance or elsewhere in the Purchaser's domestic water system.

(5) **General**

In the case of goods manufactured solely in accordance with our specification and designs and in respect of any installation work carried out by or on our behalf, our entire liability and the purchaser's sole remedies (subject to (1-4) above) and shall be as follows:

(a) we accept liability for death or personal injury to the extent that it results from our negligence that of our employees agents or subcontractors.

(b) subject to paragraph (d) below, we accept liability for direct physical damage to tangible property to the extent that such damage is caused by our negligence that of our employees agents or subcontractors.

(c) our total liability to the purchaser over and above any liability to replace under (1 - 4) above (whether in contract or in tort including negligence) in respect of any one cause of loss or damage claimed to result from any breach of our obligations hereunder, shall be limited to actual money damages which shall not exceed £20,000 provided that such monetary limit shall not apply to any liability on the part of ourselves referred to in paragraph (a) above.

(d) except as provided in paragraph (a) above but otherwise notwithstanding any provision herein contained in no event shall we be liable for the following loss or damage howsoever caused and even if foreseeable by us or in our contemplation :-

(i) economic loss which shall include loss of profits, business revenue, goodwill or anticipated savings.

(ii) damages in respect of special indirect or consequential loss or damage (other than death, personal injury and damage to tangible property).

(iii) any claim made against the purchaser by any other party (save as expressly provided in paragraph (b) above).

(e) except in respect of our liability referred to in paragraph (a) above no claim may be made or action brought (whether in contract or in tort including negligence) by the purchaser in respect of any goods supplied by us more than one year after the date of the invoice for the relevant goods.

(f) nothing in these Conditions shall confer on the purchaser any rights or remedies to which the purchaser would not otherwise be legally entitled.

(6) Notwithstanding any other provision contained herein the Purchaser's hereby agree to fully indemnify us against any damages losses costs claims or expenses incurred by us in respect of any claim brought against us by any third party for :-

(a) any loss injury or damage wholly or partly caused by any goods supplied by us or their use.

(b) any loss injury or damage wholly or partly caused by the defective installation or sub-standard workmanship or materials used in the installation of any goods supplied by us.

(c) any loss injury or damage in any way connected with the performance of this contract.

PROVIDED that this paragraph (6) will not require the Purchaser to indemnify us against any liability for our own acts of negligence or those of our employees agents or sub-contractors.

FURTHER in the case of goods supplied by us which are re-sold to and installed by a third party by the Purchaser it will be the sole responsibility of the Purchaser to test the goods immediately after their installation to ensure that inter alia they are correctly installed and are in proper working order, and are not likely to cause any loss injury or damage to any person or property.

10. VARIATION OF WARRANTY AND EXCLUSION

Should our warranty and exclusion be unacceptable we are prepared to negotiate for variation in their terms but only on the basis of an increase in the price to allow for any additional liability or risk which may result from the variation.

Purchasers are advised to insure against any risk or liability which they may incur and which is not covered by our warranty.

11. RISK AND RETENTION OF TITLE

(a) goods supplied by us shall be at the Purchaser's risk immediately upon delivery to the Purchaser or into custody on the Purchaser's behalf or to the Purchaser's Order. The Purchaser shall effect adequate insurance of the goods against all risks to the full invoice value of the goods, such insurance to be effective from the time of delivery until property in the goods shall pass to the Purchaser as hereinafter provided.

(b) property in the goods supplied hereunder will pass to the Purchaser when full payment has been made by the Purchaser to us for :-

(i) the goods of the subject of this contract.

(ii) all other goods the subject to of any other contract between the Purchaser and us which, at the time of payment of the full price of the goods sold under this contract, have been delivered to the Purchaser but not paid for in full.

(c) until property in the goods supplied hereunder passes to the Purchaser in accordance with paragraph (2) above.

(i) the Purchaser shall hold the goods in a fiduciary capacity for us and shall store the same separately from any other goods in the Purchaser's possession and in a manner which enables them to be identified as our goods.

(ii) the Purchaser shall immediately return the goods to us should our authorised representative so request. All the necessary incidents associated with a fiduciary relationship shall apply.

(d) the Purchaser's right to possess the goods shall cease forthwith upon the happening of any of the following events, namely :-

(i) if the Purchaser fails to make payment in full for the goods within the time stipulated in clause 4 hereof.

(ii) if the Purchaser, not being a company, commits any act of bankruptcy, makes a proposal to his or her creditors for a compromise or does anything which would entitle a petition for a Bankruptcy Order to be presented.

(iii) if the Purchaser, being a company, does anything or fails to do anything which would entitle an administrator or an administrative receiver or a receiver to take possession of any assets or which would entitle any person to present a petition for winding up or to apply for an administration order.

(e) the Purchaser hereby grants to us an irrevocable licence to enter at any time any vehicle or premises owned or occupied by the Purchaser or in the possession of the Purchaser for the purposes of repossessing and recovering any such goods the property in which has remained in us under paragraph (2) above. We shall not be responsible for and the Purchaser will indemnify us against liability in respect of damage caused to any vehicle or premises in such repossession and removal being damaged which it was not reasonably practicable to avoid.

(f) notwithstanding paragraph (3) hereof and subject to paragraph (7) hereof, the Purchaser shall be permitted to sell the goods to third parties in the normal course of business. In this respect the Purchaser shall act in the capacity of our commission agent and the proceeds of such sale :-

(i) shall be held in trust for us in a manner which enables such proceeds to be identified as such, and :

(ii) shall not be mixed with other monies nor paid into an overdrawn bank account.

We, as principal, shall remunerate the Purchaser as commission agent a commission depending upon the surplus which the Purchaser can obtain over and above the sum stipulated in this contract of supply which will satisfy us.

(g) in the event that the Purchaser shall sell any of the goods pursuant to clause (6) hereof, the Purchaser shall forthwith inform us in writing of such sale and of the identity and address of the third party to whom the goods have been sold.

(h) if, before property in the goods passes to the Purchaser under paragraph (2) above the goods are or become affixed to any land or building owned by the Purchaser it is hereby agreed and declared that such affixation shall not have the effect of passing property in the goods to the Purchaser.

Furthermore if, before property in the goods shall pass to the Purchaser under paragraph (2) hereof, the goods are or become affixed to any land or building (whether or not owned by the Purchaser), the Purchaser shall:-

(i) ensure that the goods are capable of being removed without material injury to such land or building.

(ii) take all necessary steps to prevent title to the goods from passing to the landlord of such land or building.

(iii) forthwith inform us in writing of such affixation and of the address of the land or building concerned.

The Purchaser warrants to repair and make good any damage caused by the affixation of the goods to or their removal from any land or building and to indemnify us against all loss damage or liability we may incur or sustain as a result of affixation or removal.

(i) in the event that, before property in the goods has passed to the Purchaser under paragraph (2) hereof, the goods or any of them are lost, stolen, damaged or destroyed :-

(i) the Purchaser shall forthwith inform us in writing of the fact and circumstances of such loss, theft, damage or destruction.

(ii) the Purchaser shall assign to us the benefit of any insurance claim in respect of the goods so lost, stolen, damaged or destroyed.

12. NON-PAYMENT

If the Purchaser shall fail to make full payment for the goods supplied hereunder within the time stipulated in clause 4 hereof or be in default of payment for any other reason then, without prejudice to any of our other rights hereunder, we shall be entitled to stop all deliveries of goods and materials to the Purchaser, including deliveries or further deliveries of goods under this contract. In addition we shall be entitled to terminate all outstanding orders.

13. RISK

All goods sold by us shall be at the sole risk of the Purchaser from the date of despatch by us of the invoice for their price.

14. VALUE ADDED TAX

All prices quoted are exclusive of Value Added Tax which will be charged at the rate ruling at the date of despatch of invoice.

15. TRADE SALES ONLY

We are only prepared to deal with those who are not consumers within the terms of the Unfair Contract Terms Act 1977, the Sale of Goods Act 1979 and the Supply of Goods and Services Act 1982. Accordingly any person who purchases from us shall be deemed to have represented that he is not a consumer by so purchasing.

16. JURISDICTION

The agreement is subject to English/Scottish law and any dispute arising hereunder shall be settled in accordance therewith dependent upon the location.