

# Glow-worm

## Instructions for Use Installation and Servicing

To be left with the user

*SWIFT*  
*FLOW*

75e

G.C. No. 47 313 16

Fanned Flue Combination Boiler

*With Honeywell gas control*



This is a Cat I<sub>2H</sub> Appliance

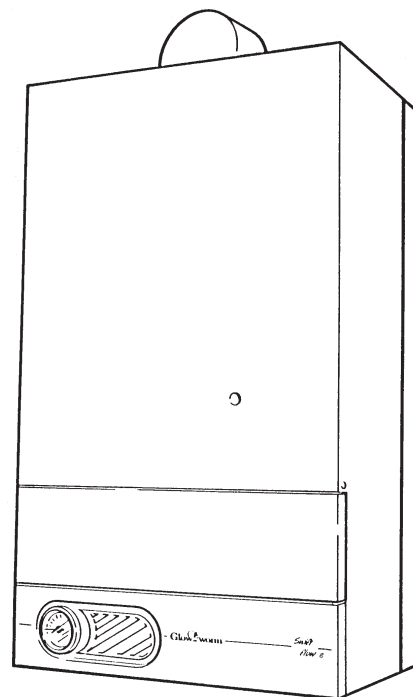

5226

*The instructions consist of three parts, User, Installation and Servicing Instructions, which include the Guarantee Registration Card. The instructions are an integral part of the appliance and must, to comply with the current issue of the Gas Safety (Installation and Use) Regulations, be handed to the user on completion of the installation.*

### Guarantee Registration

Thank you for installing a new Glow-worm appliance in your home.

Glow-worm appliances' are manufactured to the very highest standard so we are pleased to offer our customers' a Comprehensive First Year Guarantee.

In the center pages are to be found your Guarantee Registration Card, which we recommend you complete and return as soon as possible.

If this card is missing you can obtain a copy or record your registration by telephoning the Heatcall Customer Service number 01773 828100.

Our Guarantee gives you peace of mind plus valuable protection against breakdown by covering the cost of:

- All replacement parts**
- All labour charges**
- All call-out charges**

REGISTER YOUR GLOW-WORM APPLIANCE  
FOR 1ST YEAR GUARANTEE PROTECTION

**CALL 0181 380 2555**

**HEATCALL**  
One Contact Local Service

Customer Services:  
Tel: (01773) 828100  
Fax: (01773) 828070

Hepworth Heating Ltd.,  
Nottingham Road, Belper, Derbyshire. DE56 1JT  
General/Sales enquiries:  
Tel: (01773) 824141 Fax: (01773) 820569

# Important Information

## Testing and Certification

This boiler is tested and certificated for safety and performance. It is therefore important that no alteration is made to the boiler, without permission, in writing, from Hepworth Heating Ltd.

Any alteration not approved by Hepworth Heating Ltd., could invalidate the certification, boiler warranty and may also infringe the current issue of the Statutory Requirements, see Section 1.4.

## CE Mark

This boiler meets the requirements of Statutory Instrument No. 3083 The boiler (Efficiency) Regulations, and therefore is deemed to meet the requirements of Directive 92/42/EEC on the efficiency requirements for new hot water boilers fired with liquid or gaseous fuels.

Type test for purposes of Regulation 5 certified by: Notified body 0087.

Product/production certified by: Notified body 0087.

The CE mark on this appliance shows compliance with:

1. Directive 90/396/EEC on the approximation of the laws of the Member States relating to appliances burning gaseous fuels.
2. Directive 73/23/EEC on the harmonization of the Laws of the Member States relating to the electrical equipment designed for use within certain voltage limits.
3. Directive 89/336/EEC on the approximation of the Laws of the Member States relating to electromagnetic compatibility.

## Substances Hazardous to Health

The adhesives and sealants used in this appliance are cured and give no known hazard in this state.

INSULATION PADS/CERAMIC FIBRE, GLASSYARN, MINERAL WOOL

These can cause irritation to skin, eyes and the respiratory tract.

If you have a history of skin complaint you may be susceptible to irritation. High dust levels are usual only if the material is broken.

Normal handling should not cause discomfort, but follow normal good hygiene and wash your hands before eating, drinking or going to the lavatory.

If you do suffer irritation to the eyes or severe irritation to the skin seek medical attention.

CONTENTS	DESCRIPTION	SECTION	PAGE No.
<b>INSTRUCTIONS FOR USE</b>	Introduction		3
	Clock Settings		4
	Lighting the Boiler		5
<b>INSTALLATION INSTRUCTIONS</b>	General Data	1	6
	Boiler Position	2	8
	Flue and Ventilation	3	9
	Heating System	4	11
	Domestic Hot Water System	5	14
	Installation Preparation	6	14
	Flue Preparation	7	16
	Gas and Water Connections	8	17
	Electrical Connections	9	18
	Boiler Fixing	10	20
	Commissioning	11	21
<b>SERVICING INSTRUCTIONS</b>	General Data	1	25
	Servicing	2	26
	Fault Finding	3	27
	Replacement Parts	4	34
	Spare Parts	5	46

# Instructions for Use

## Introduction

Please read these instructions and follow them carefully for the safe and economical use of your Combination boiler.

This boiler must have been installed by a competent person in accordance with the rules in force in the countries of destination.

Once the pilot has been lit and the controls set, the boiler is automatic in operation.

The Swift-flow combination boiler is able to provide room heating as part of a central heating system and domestic hot water direct from the cold water supply, without the need for secondary storage.

The boiler can be fitted with one of two makes of clock, which look like this:-

Clock / Timer

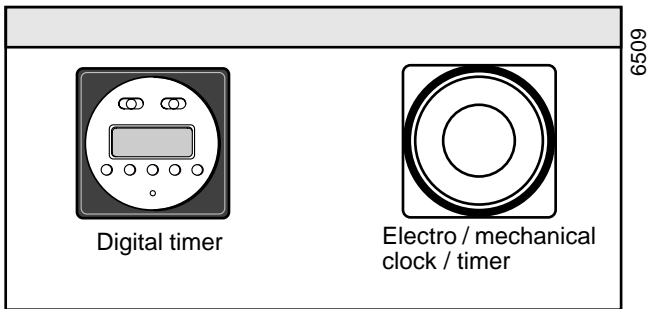

### IMPORTANT NOTICE:

This boiler is for use only on G20 gas.

## Gas Leak or Fault

If a gas leak or fault exists or is suspected, turn the boiler off and consult your local gas company or your local installation/ servicing company.

## Domestic Hot Water Temperature

NOTE. The mains water temperature in the winter is lower than in the summer.

The water temperature can be increased or reduced by adjusting the flow rate at the hot water draw off tap.

## Boilers Installed in Compartments

If the boiler has been fitted into a compartment or cupboard, do not obstruct the compartment air supply vents.

Do not use the compartment for storage.

## Electrical Supply

WARNING. The boiler must be earthed.

The boiler must be connected to a 230V~50Hz permanent supply.

Connection of the whole electrical system of the boiler and any heating system controls to the electrical supply, must be through one common isolator.

Isolation should preferably be by a double pole switched fused spur box. The fused spur box should be readily accessible and preferably adjacent to the appliance. It should be identified as to its use.

Alternatively a fused 3A 3 pin plug and shuttered unswitched socket may be used.

The colours of three core flexible cable are, blue - neutral, brown - live, green and yellow - earth.

As the markings on your plug may not correspond with these colours continue as follows:-

The wire coloured blue must be connected to the terminal marked "N" or "Black".

The wire coloured brown must be connected to the terminal marked "L" or "Red".

The wire coloured green and yellow must be connected to the terminal marked "E" or "Green" or the earth symbol  $\perp$ .

PVC flexible cable having a conductor size of 0.75mm<sup>2</sup> (24/0.20mm) must be used within the boiler casing to connect to the boiler.

## Electrical Supply Failure

The boiler will not work without an electrical supply.

Normal operation of the boiler should resume when the electrical supply is restored.

Note. The boiler safety cutoff may have operated, please refer to the following section to reset.

Reset any external controls, to resume normal operation of the central heating.

The digital timer, has a lithium battery back up and will not need resetting.

## Boiler Safety Cutoff Reset Button

The boiler is fitted with a safety cutoff device to prevent damage through overheating.

Should the main burner go out during a demand the red neon on the Reset Button will light.

In certain circumstances the red neon light may not come on, due to no system demand. It is suggested that a hot water draw off tap be opened to create a demand, the neon should then come on.

Allow the boiler and system to cool down waiting at least a minimum of four minutes before pressing the Reset button.

If the problem persists, turn the boiler off and consult the local gas company or your installation/ servicing company.

# Instructions for Use

## Setting Instructions for Electro/mechanical Clock - if fitted

This clock has a twenty four hour dial, that is, 1pm is 13.

To set the time, turn the whole face clockwise until the pointer is against the time of day.

To set any "Off" time, push the tappets outwards.

To set any "On" time, push the tappets inwards.

Time can be set either "On" or "Off" in fifteen minute segments.

Note. The clock supplied could be fitted with an override device, see diagram 1, which switches the clock programme "On" or "Off" permanently.

The switch will need to be repositioned to resume programmed working.

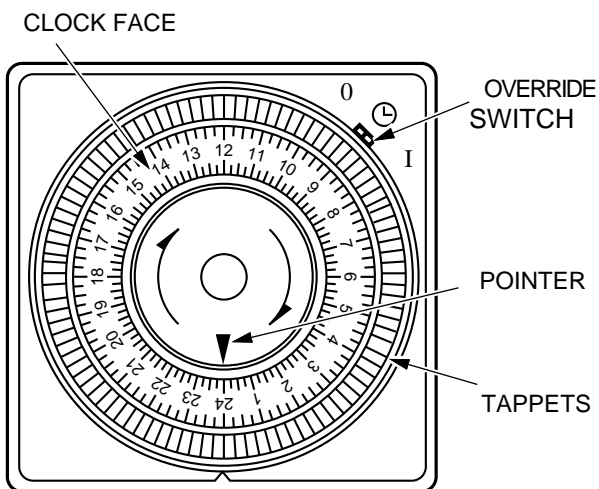

4956

- 0 CONSTANT OFF
- P PROGRAMMED
- I CONSTANT ON

Diagram 1

## Setting Instructions for the 7 Day Digital Clock/Timer

This is a 24 hour clock/timer, that is 1pm is 13:00, and has 8 "ON" and 8 "OFF" daily switching actions.

It is fitted with a lithium battery back up which protects the programme in the event of an electrical failure. The battery should have a life of several years.

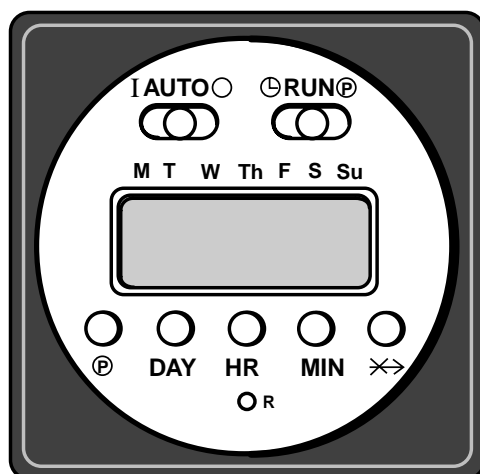

5673

Diagram 2

## Setting the Clock

1. With both AUTO and RUN switches set to the central position, press R reset button, the display will flash.
2. Set RUN switch to .
3. Set day of week by pressing button DAY.
4. Set time of day by pressing buttons HR and MIN.
5. Set RUN switch to the central position, colon will flash, this indicates the clock is set.

With the clock set, the factory preset programme shown below will operate.

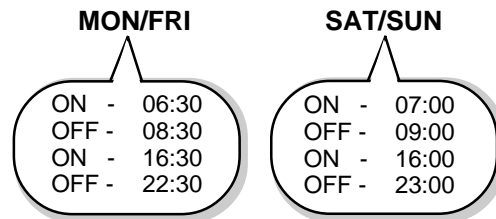

## Setting Timed Programmes

With the clock set to the correct time, see SETTING THE CLOCK paragraphs 1-4, and then continue as follows:

1. Set RUN switch to , the display will indicate the 1st (ON) preset programme and the symbol .
2. Set day of week to be programmed by pressing the DAY button.

Note: The days can be selected individually or as groups:

Mon-Fri., Mon-Sat., Mon-Sun., Sat/Sun.

An arrow will be displayed under the day or days selected.

3. Set time of day by pressing the buttons HR and MIN.
4. Press button to confirm programmes, the display will indicate the 2nd (OFF) preset programme and subsequently, 3rd, 4th, 5th, 6th, 7th, 8th.
5. Repeat procedures 2, 3 and 4 until desired programmes are set.

Note. It is not a requirement to use the 8 on/off programmes.

6. Set the RUN switch the central position, your appliance will now operate at the programmed times.

General Notes.

With the AUTO switch in the I position the central heating will operated constantly ON.

With the AUTO switch in the O position the central heating will not operate.

Soft Override button indicated by the symbol , this function will override the current central heating programme for the next available.

ON time programmes are indicated by the symbol .

# Instructions for Use

## To Light the Boiler

1. Check that all five isolating valves are open, the slots in line with the length of the valve, see diagram 3.
2. Open the door, by pushing at the side opposite to the hinge.
3. CAUTION. A sealed pressurised system must be filled and pressurised by a competent person.

Only operate the boiler when you are sure that the system has been filled and pressurised. Check this by looking at the pressure gauge "A", diagram 4, it should read 0.7bar minimum.

4. Check reset button neon, refer to previous instructions on page 3.
5. Open a hot water tap, check that water flows, then close it.
6. If you are in any doubt about the boiler being filled with water contact your installation/servicing company or the local gas company.
7. Check that the electrical supply to the boiler is ON at the external isolator.
8. Set switch "C", clock/timer (if fitted) and any remote controls as required.

Close the door.

In certain circumstances, a surge in water pressure may cause the appliance to operate momentarily, this will be indicated by the pump starting and the fan speed increasing. This is quite normal.

## Central Heating Selector Switch

For central heating set switch "C" to "On" as shown in diagram 4. The main burner will light.

When the heating is controlled by a room thermostat and/or a time switch, switch "C" must be set "On".

If a hot water tap is opened while the boiler is on for heating, the burner flame will increase in size and priority will be given to hot water.

When the hot water tap is closed, the main burner flames will decrease in size but will remain alight until the boiler controls or any heating controls switch it off.

Which ever position switch "C" is in domestic hot water will be available.

## To Turn the Central Heating Off

To turn the heating off for short periods, set switch "C" to "Off" as shown in diagram 4.

To turn on again set switch "On", see diagram 4.

## To Turn the Boiler Off

To turn the boiler off, isolate the boiler from the electrical supply.

To turn on again following the operating instructions.

## Domestic Hot Water Temperature

NOTE. The mains water temperature in the winter is lower than in the summer.

The water temperature can be increased or reduced by adjusting the flow rate at the hot water draw off.

## Maintenance and Servicing

To ensure the continued efficient and safe operation of the appliance it is recommended that it is checked and serviced as necessary at regular intervals. The frequency of servicing will depend upon the particular installation conditions and usage, but in general once a year should be enough.

If this appliance is installed in a rented property there is a duty of care imposed on the owner of the property by the current issue of the Gas Safety (Installation and Use) Regulations, Section 35.

Servicing/maintenance should be carried out by a competent person in accordance with the rules in force in the countries of destination.

To obtain service, please call your installer or Heatcall (Glow-worm's own service organisation) using the telephone number behind the controls access door, see diagram 4.

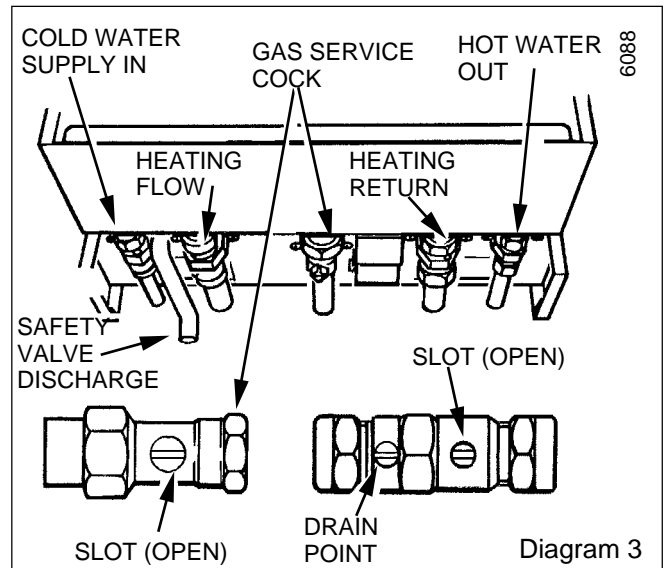

Diagram 3

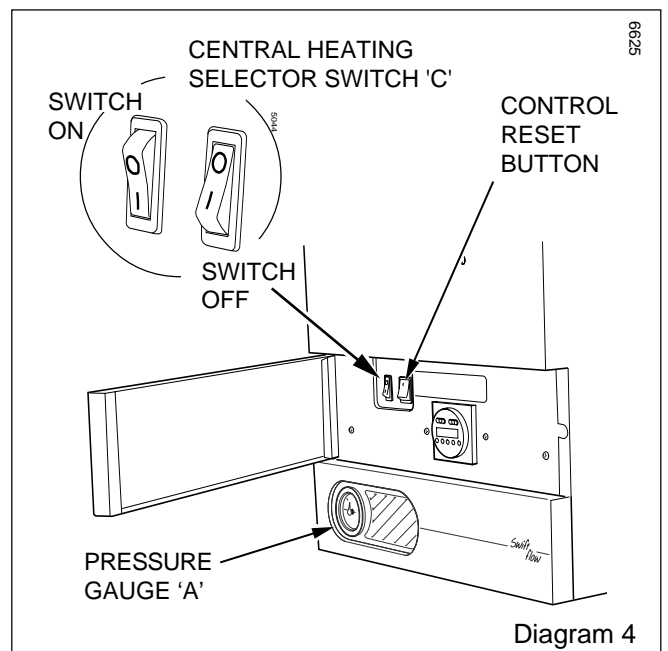

Diagram 4

# Instructions for Use

## Clearances

The boiler requires a clearance in front, below and at the sides of the casing for safety, servicing and maintenance access, see diagram 2.1.

## Protection Against Freezing

If the boiler is to be out of use for any long periods during severe weather, it is recommended that the whole system, including the combination boiler, should be drained to avoid the risk of freezing.

If in doubt, contact you installation/servicing company for advice.

## Draining and Filling

**CAUTION.** This boiler works in a pressurised system which must only be drained, refilled and pressurised by a competent person.

Note: If the pressure gauge indicates a loss of system pressure, that is, less than 0.7bar, YOU MUST CONTACT YOUR INSTALLER.

## Pressure Relief Safety Valve

**CAUTION.** A pressure relief safety valve and discharge pipe is fitted to the boiler. This valve must not be touched. Should there be any discharge from the pipe, turn the boiler off, isolate from the electrical supply and contact your installation/servicing company.

## Cleaning

**WARNING.** This appliance contains metal parts (components) and care should be taken when handling and cleaning with particular regard to edges.

The boiler casing can be cleaned using a mild liquid detergent with a damp cloth, then a dry cloth to polish.

Do not use any form of abrasive or solvent cleaner as you may damage the paint work

## Boiler Casing

**CAUTION.** Do not remove or adjust the casing in any way, as incorrect fitting may result in incorrect operation or failure to operate at all. If in doubt seek advice from the local gas company or your installation/servicing company.

## Replacement Parts

If replacement parts are required apply to your local supplier or British Gas.

Please quote the name of the appliance.

# 1 General

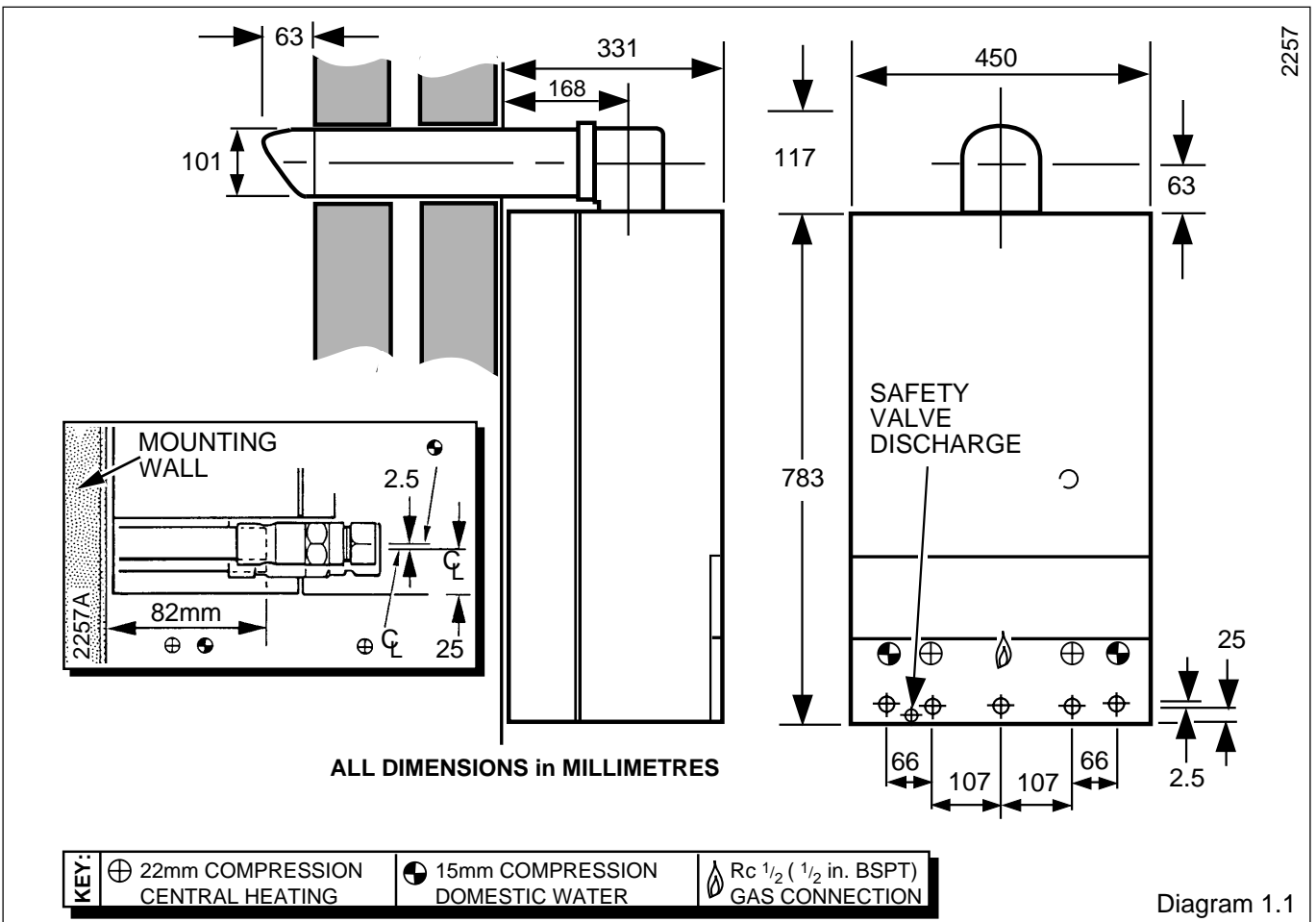

# 1 General

## 1.1 Installation

Materials and equipment should be fit for their purpose and of suitable quality and workmanship.

## 1.2 Important Notice

This boiler is for use only on natural gas, G20.

## 1.3 Sheet Metal Parts

WARNING. When installing or servicing this boiler care should be taken when handling the edges of sheet metal parts to avoid any possibility of personal injury.

## 1.4 Requirements

The installation of this boiler must be carried out by a competent person in accordance with the rules in force in the countries of destination.

Manufacturer's instructions, supplied.

Manufacturer's instructions must not be taken as overriding statutory requirements.

## 1.5 Data Label

The data label is on the inner case cover.

## 1.6 Data

See tables 1 and 2

TABLE 1 75e		C.H. MAX	D.H.W. MAX	MIN
NOMINAL	kW	18.2	27.5	10.7
HEAT INPUT(NETT)	Btu/h	62,000	93,750	36,576
NOMINAL	kW	16.12	22.0	8.79
HEAT OUTPUT	Btu/h	55,000	75,000	30000
BURNER PRESSURE	mbar	8.0	15.6	2.4
	in.wg	3.4	6.3	1.0
APPROX. GAS RATE	m <sup>3</sup> /h	2.0	2.6	1.2
	ft <sup>3</sup> /h	69.5	92.5	42.1

## 1.7 Gas Supply

The gas installation shall be in accordance with the rules in force in the countries of destination.

The supply from the governed meter must be of adequate size to provide a steady inlet working pressure of 20mbar (8in wg) at the boiler.

## 1.8 Electrical Supply

WARNING. This boiler must be earthed.

All system components shall be of an approved type.

The electrical installation shall be in accordance with the rules in force in the countries of destination.

Connection of the whole electrical system of the boiler and any heating system controls to the electrical supply, must be through one common isolator.

Isolation should be by a double pole switched fused spur box, having a minimum contact separation of 3mm in each pole. The fused spur box should be readily accessible and preferably adjacent to the appliance. It should be identified as to its use.

Alternatively, a fused 3A 3pin plug and unswitched socket may be used, provided they are not used in a room containing a bath or shower.

The mains supply cable and other cables connected to the boiler must be the PVC flexible type of at least 0.75mm<sup>2</sup> (24/0.20mm).

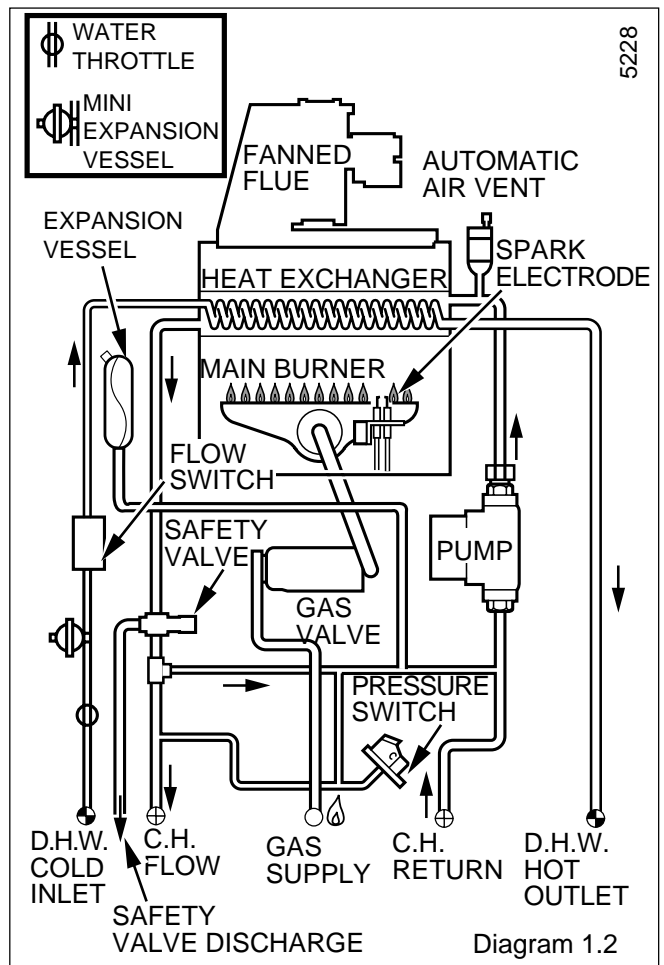

# 1 General

**TABLE 2**

<b>Lift Weight</b>	37.0kg (81.4lb)	<b>* D.H.W working pressure</b>	0.5 to 10bar (7.25 to 188lbf/in <sup>2</sup> )
<b>Total Weight</b>	50.4kg (111lb)	<b>■ Maximum Heating system water content using fitted expansion vessel.</b>	119 litres (26.2 gallons) with a cold fill pressure of 0.7bar
<b>● Gas connection</b>	Rc <sup>1</sup> / <sub>2</sub> (1/2in BSPT)	<b>Electrical supply</b>	230V~50Hz
<b>● Heating and return</b>	22mm compression	<b>Electrical rating</b>	154W fused 3A
<b>● Domestic hot water</b>	15mm compression	<b>Internal Fuse rating</b>	1) Type T2A 2) Type T630mA
<b>Safety valve</b>	Preset 3bar (43.5lbf/in <sup>2</sup> )		
<b>Safety valve discharge</b>	15mm copper		
<b>Water content</b>	1.74 litres (0.38 gallon)		
<b>■ Expansion vessel capacity</b>	8 litres (1.76 gallons)		
<b>Heating cold fill pressure minimum</b>	0.7bar (10.1lbf/in <sup>2</sup> )		

- Ball valves are fitted in water and gas connections, plus a drain point on all water connections.
- \* Boiler starts at an inlet pressure of 0.5bar but requires 0.8bar for maximum output.
- For larger systems use an additional expansion vessel, see Section 4.

# 2 Boiler Position

## 2.1 Location

This boiler must be installed in accordance with the rules in force in the countries of destination.

This boiler is not suitable for fitting outside.

Any electrical switch must be positioned so that it cannot be touched by a person using the bath or shower.

The boiler must be mounted on a flat wall which is sufficiently robust to take its weight, refer to

Section 1, "Data".

If the location of the boiler or any part of the system is subject to severe cold weather conditions, it is recommended that a frost thermostat is fitted. Any part of the system that may be vulnerable to freezing must be protected.

If the boiler is to be fitted into a cupboard, compartment or unusual location, special procedures are necessary.

Make sure that the cupboard or compartment air vents are positioned to be clear of obstructions at all times, refer to Section 3, Cupboard/Compartment Ventilation.

## 2.2 Clearances

The boiler should be positioned so that at least the minimum operational and servicing clearances are provided, see diagram 2.1. Additional clearances may be required around the boiler for installation.

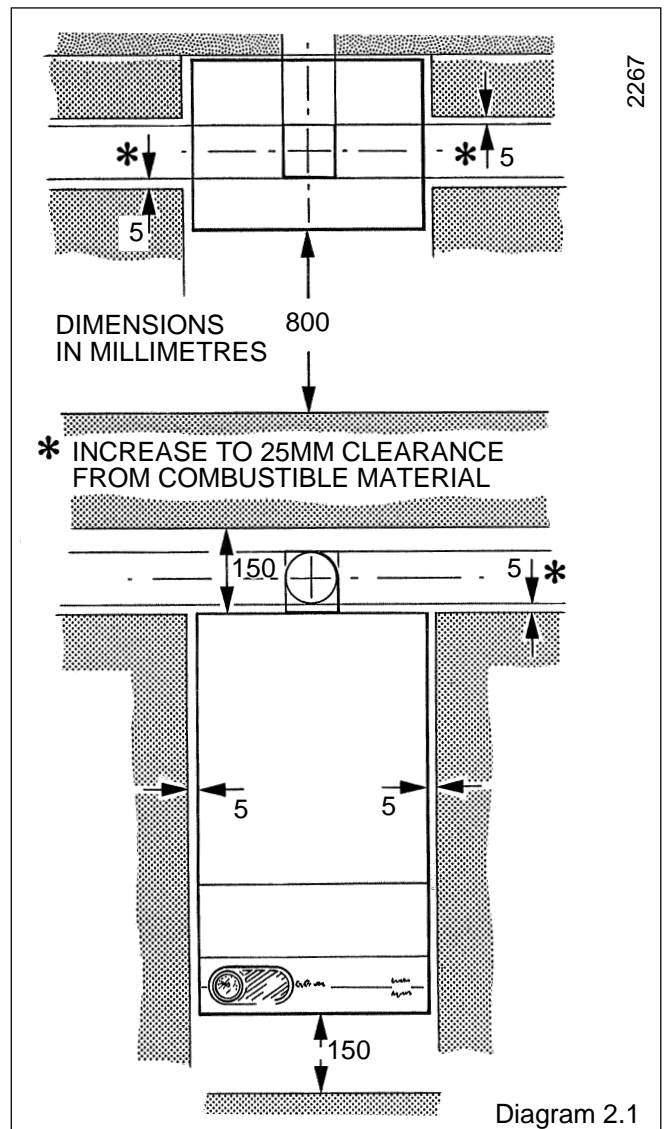



## 3 Flue and Ventilation

### 3.1 Flue

The flue must be installed in accordance with the rules in force in the countries of destination.

### 3.2 Flue Position and Length

The air and flue ducting connect to the top of the boiler using the elbow which can be positioned in one of three possible directions:

Rearward, left or right.

The standard flue is able to provide the duct length range shown in diagram 3.1 for a rear flue or diagram 3.2 for a side flue.

If a longer flue duct is required, do not extend the ductings.

A 1, 2 and 3metre flue system and elbow/ terminal kit must be used and can be supplied.

This is able to provide the duct length range shown in diagram 3.3 for rear flue or diagram 3.4 for a side flue.

A Flue Bend Kit or Vertical Flue Kit can be supplied with instructions.

To make a neat finish to the flue outlet a flue collar kit, part No. 443286, with instructions, is available.

The use of this collar will mean that the flue lengths will need to be altered, full instructions are given in the kit.

### 3.3 Terminal Position

The minimum acceptable siting dimensions for the terminal from obstructions, other terminals and ventilation openings are shown in diagram 3.5.

The terminal must be exposed to the external air, the position allowing free passage of air across it at all times.

Car port or similar extensions of a roof only, or roof and one wall, require special consideration with respect to any openings, doors, vents or windows under the roof. Care is required to protect the roof if made of plastic sheeting. If the car port comprises of a roof and two or more walls seek advice from the local gas undertaking before installing the boiler.

If the terminal is fitted within 600mm below plastic guttering, an aluminium shield 1500mm long should be fitted immediately beneath the guttering or eaves. If the terminal is fitted within 450mm below painted eaves or a painted gutter, an aluminium shield 750mm long should be fitted immediately beneath the guttering or eaves.

### 3.4 Timber Frame Buildings

If the boiler is to be installed in a timber frame building seek advice from the local gas undertaking or from Hepworth Heating Ltd.

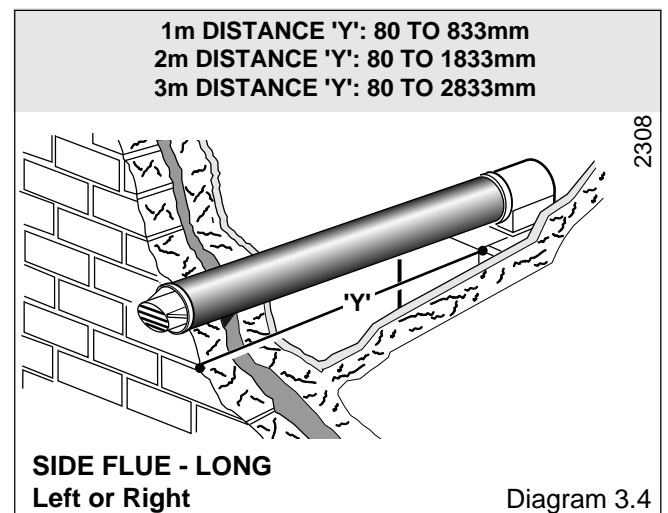
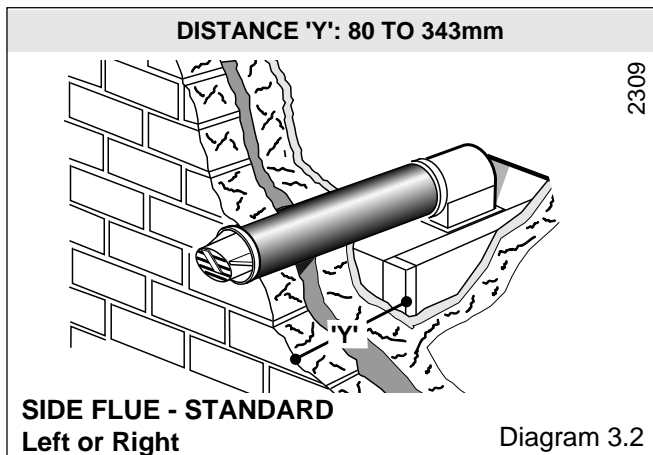
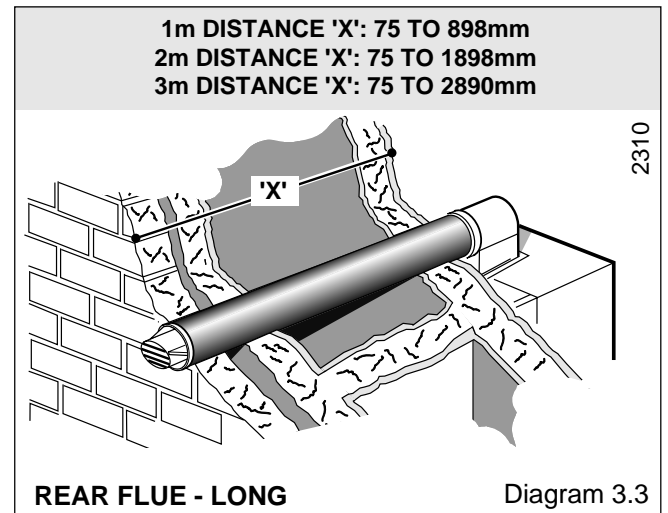
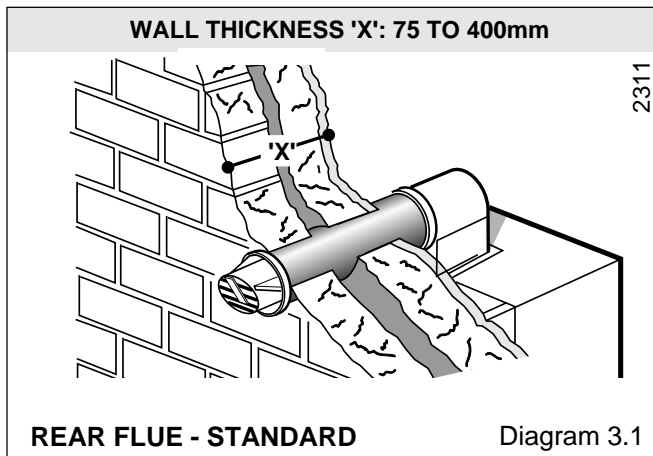

## 3 Flue and Ventilation

### 3.5 Terminal Guard

A terminal guard is required if persons could come into contact with the terminal or the terminal could be subject to damage.

If a terminal guard is required, it must be positioned to provide a minimum of 50mm clearance from any part of the terminal and be central over the terminal.

The guard should be similar to that shown in diagram 3.5 and can be bought from:

*Tower Flue Components Ltd.  
Morley Road  
Tonbridge  
Kent  
TN9 1RA*

their type K3

### 3.6 Room Ventilation

Ventilation must be provided in accordance with the rules in force in the countries of destination. The boiler is room sealed, so where the boiler is fitted in a room or space, a permanent air vent is not required.

### 3.7 Cupboard/Compartment Ventilation

If the boiler is to be fitted in a cupboard or compartment, permanent high and low level air vents must be provided for ventilation. The vents must have at least the effective areas shown in Table 2.

Position of Air Vent	Air from Room or Internal space	Air Direct from Outside
High Vent	248cm <sup>2</sup> 38in <sup>2</sup>	124cm <sup>2</sup> 19in <sup>2</sup>
Low Vent	248cm <sup>2</sup> 38in <sup>2</sup>	124cm <sup>2</sup> 19in <sup>2</sup>

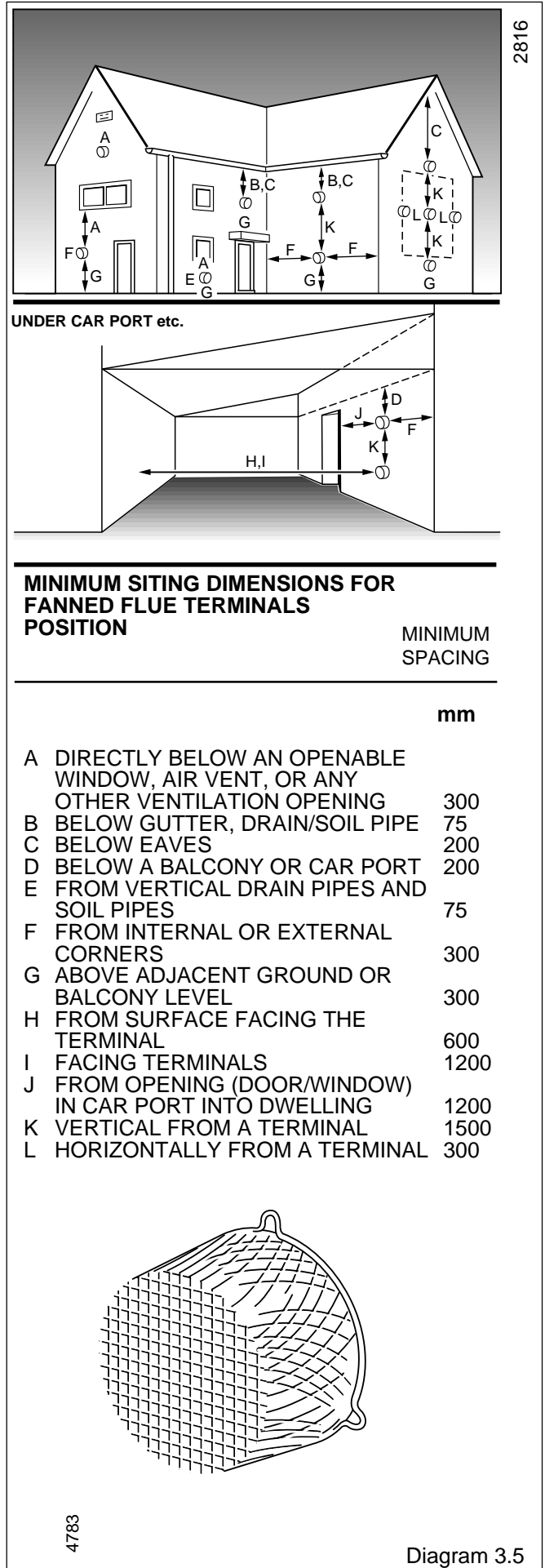

# 4 Heating System

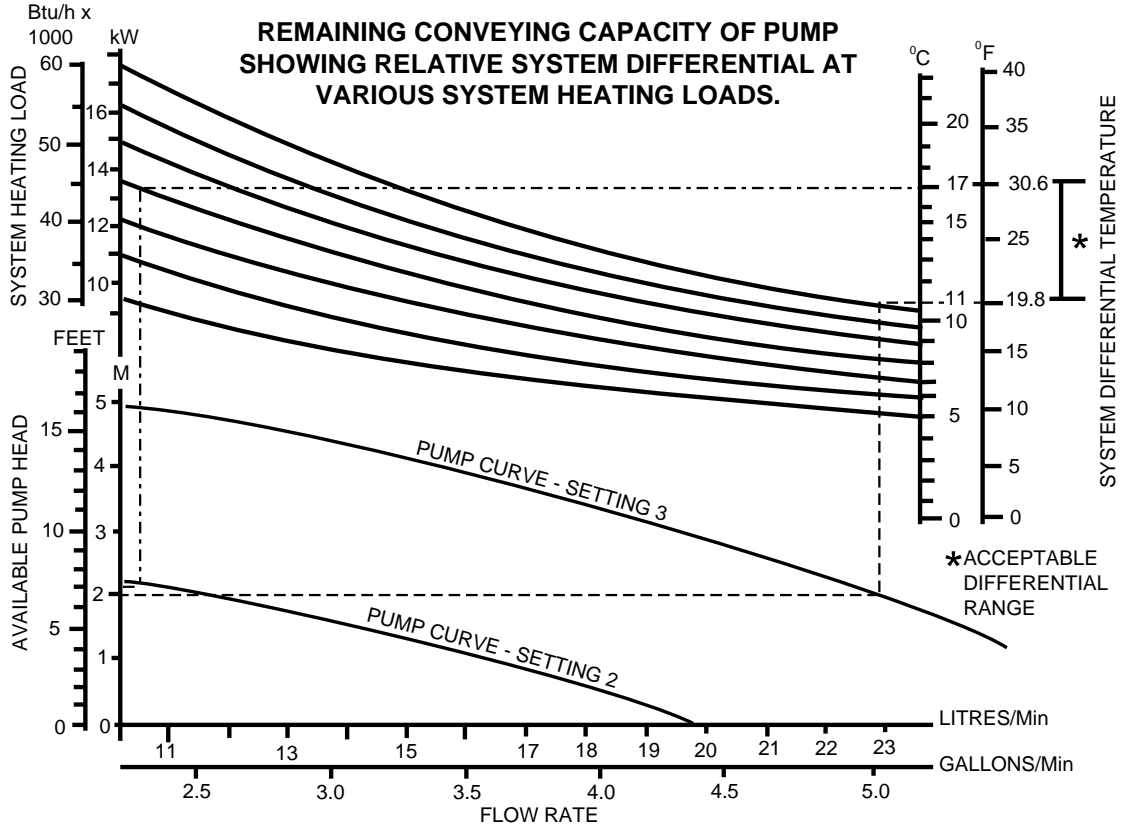

GRUNDFOS

Diagram 4.1

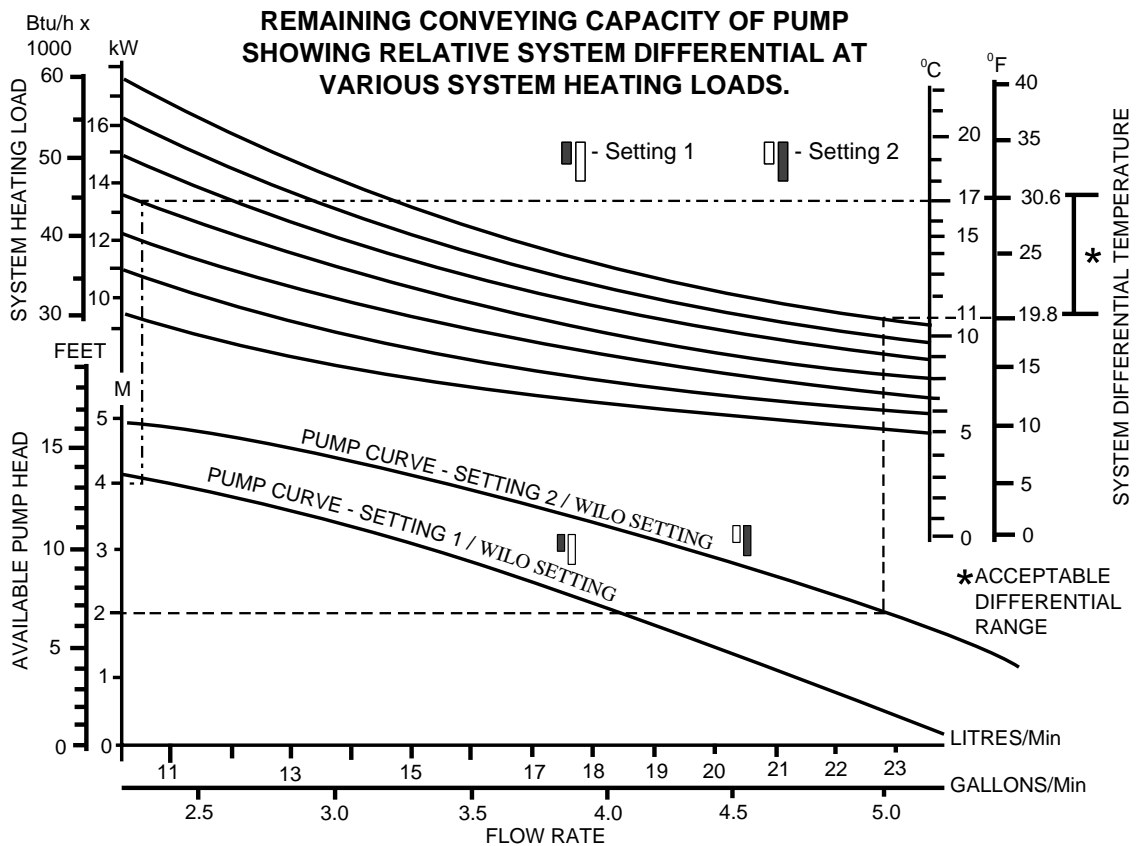

WILO

Diagram 4.1A

## 4 Heating System

### 4.1 General Notes

The boiler is intended for use in a sealed system only.

### 4.2 Safety Valve

The safety valve is an integral part of the boiler.

It cannot be adjusted but has a manual test device.

### 4.3 Pressure Gauge

A pressure gauge is incorporated into the boiler to indicate the system pressure.

The gauge has a cold fill set pointer.

### 4.4 Pump

The circulation pump is integral with the boiler.

The remaining circulating pressure head available from the boiler is shown in diagram 4.1, Grundfos or diagram 4.1A, Glow-worm Wilo.

### 4.5 Expansion Vessel

The boiler has an integral expansion vessel with a capacity of 8Litres, (1.76gall). If the system water content exceeds the maximum quoted in Section 1, Data, an additional vessel should be connected into the system as close as possible to the central heating return connection of the boiler, see diagram 4.2.

The pressure shall not be less than the static head at the point of connection, that is, the height of the top point of the system above the expansion vessel.

### 4.6 Flow Rate

A valve must be incorporated in the main flow or return of the system, valve "A" shown in the flow diagram 4.2. This valve must be lockable and positioned so that inadvertent closure or unauthorised interference is not possible. The design differential can be between 11°C (20°F) and 17°C (30°F), dependent upon the system resistance and the available pump head.

### Grundfos Pump

The pump adjuster should normally be left at maximum (3) but in some cases it is permissible to adjust the pump to a lower setting (2), see diagram 4.1.

To use diagram 4.1 start with the required heating system load.

In the example shown the 80e maximum boiler output has been chosen, 17.6kW (60,000Btu/h).

Draw a horizontal line from the required system differential temperature axis to intersect the curve.

In the example 11°C (19.8°F) has been chosen, shown — — — — . At the point of intersection draw a vertical line to cross the pump curve, from this point draw a further horizontal line to determine the available pump head. In the example 1.9m (6ft4in) is available. A greater pump head can be achieved by choosing a higher system differential temperature, up to a maximum of 4.0m (13ft) at a system differential of 17°C (30.6°F). The system must be designed such that the available pump head is not exceeded.

If the heating system load is less than 13.2kW (45,000Btu/h) then it is permissible to adjust the pump setting to (2), shown — — — — . This results in an available pump head of 2.1m (7ft). This is the maximum that can be achieved with the pump at this setting.

### Glow-worm Wilo Pump

The pump adjuster should normally be left at maximum (2) but in some cases it is permissible to adjust to a lower setting (1), see diagram 4.1A.

To use diagram 4.1A start with the required heating system load.

In the example shown the 80e maximum boiler output has been chosen, 17.6kW (60,000Btu/h).

Draw a horizontal line from the required system differential temperature axis to intersect the curve. In the example 11°C (19.8°F) has been chosen, shown — — — — . At the point of intersection draw a vertical line to cross the pump curve. From this point draw a further horizontal line to determine the available pump head. In the example 1.9m (6ft3in) is available. A greater pump head can be achieved by choosing a higher system differential temperature, up to a maximum of 4.0m (13ft) at a system differential of 17°C (30.6°F). The system must be designed such that the available pump head is not exceeded.

If the heating system load is less than 13.2kW (45,000Btu/h) then it is permissible to adjust the pump setting to (1), shown — — — — . This results in an available pump head of 4.2m (13ft9in). This is the maximum that can be achieved with the pump at this setting.

### 4.7 Bypass

It is essential that a bypass is fitted in all installations, 22mm o.d. minimum. The bypass must have a lockable valve "B" in diagram 4.2, incorporated in a position so that inadvertent closure or unauthorised interference is not possible.

The bypass MUST be fitted before any system control. A radiator bypass is NOT recommended.

### 4.8 Make-up

Provision should be made for replacing water lost from the system using a make up bottle mounted in a position higher than the top point of the system, connected through a non-return valve to the return side of the heating circuit, see diagram 4.2.

Alternatively, provision for make-up can be made by pre-pressurisation of the circuit

# 4 Heating System

## 4.9 Filling Sealed Systems

Provision for filling the system at a low level must be made. Three methods of filling are shown in diagram 4.3.

There must be no permanent connection to the mains water supply, even through a non-return valve.

NOTE: It is important that fittings used for connection to potable water comply with the water undertakers requirements.

## 4.10 Corrosion Inhibitor

If an inhibitor is to be used in the system, contact the inhibitor manufacturer so that they can recommend their most suitable product.

When fitting the boiler into an existing system, special care should be taken to drain the entire system, including radiators, then thoroughly cleaning out before fitting the boiler whether or not adding an inhibitor.

## 4.11 Draining

A draining tap must be provided at the lowest points of the system, which will allow the entire system to be drained. An additional draining tap **MUST** be fitted close to the boiler.

The flow and return isolation valves are provided with drain points for boiler heat exchanger drainage.

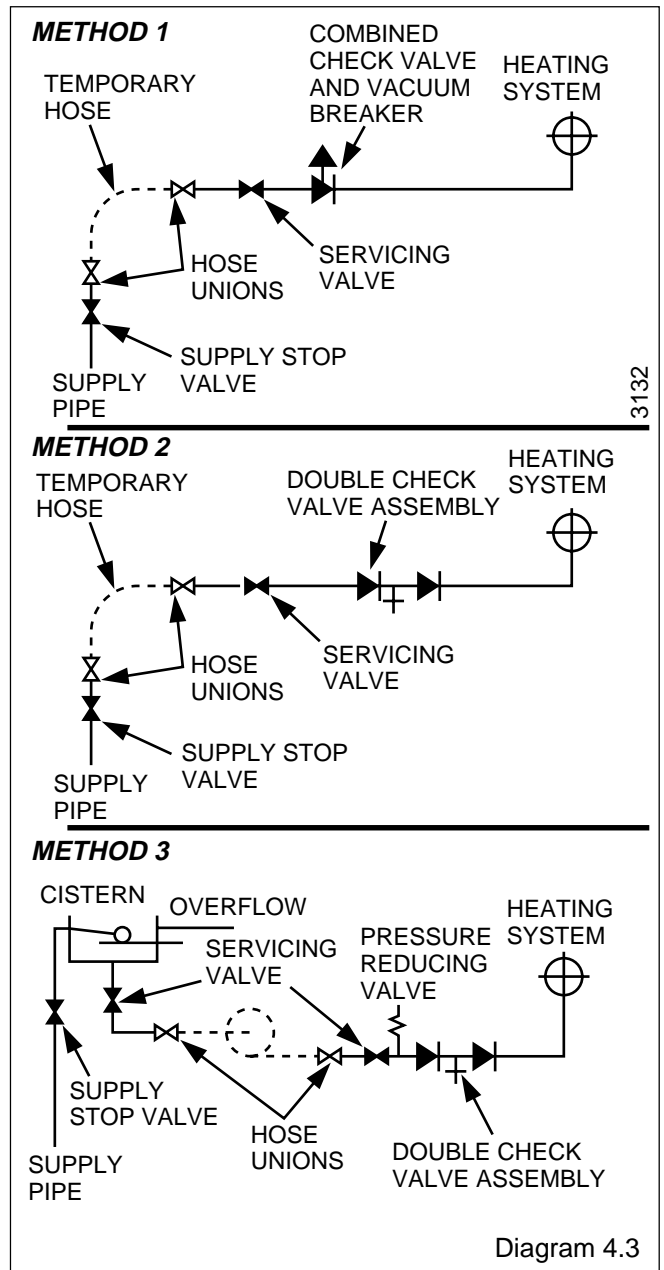
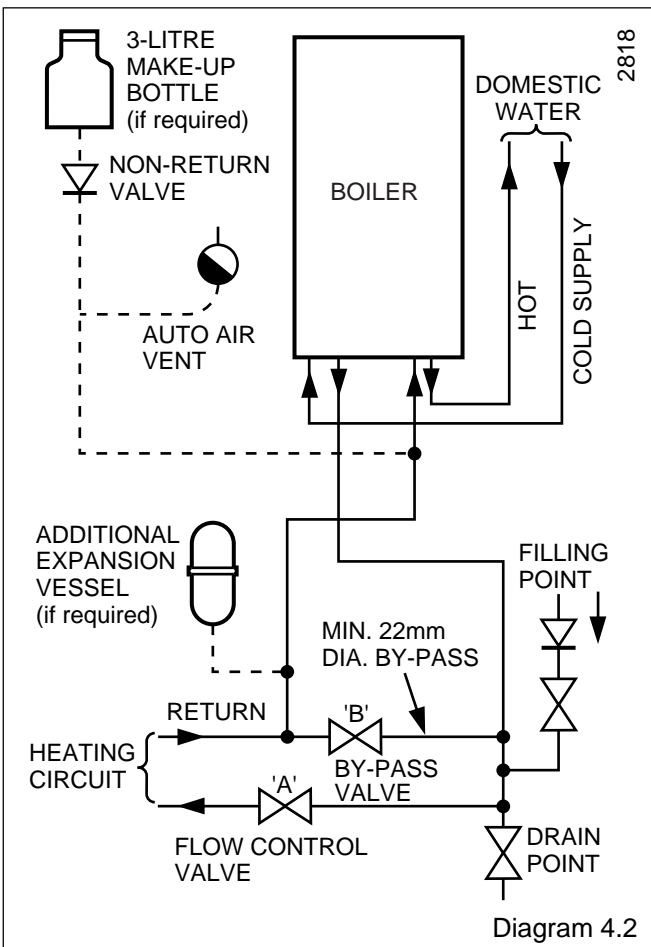

## 5 Domestic Hot Water System

### 5.1 General

The domestic hot water service must be in accordance with the rules in force in the countries of destination.

### 5.2 Water Pressure

For the minimum and maximum working pressures of the domestic hot water circuit of the boiler refer to Section 1.6 Data.

If the cold water supply pressure exceeds the maximum, a governor must be fitted in the supply to the boiler to reduce the pressure to within the limits given.

### 5.3 "Hard" Water Areas

In areas where the water is "hard", more than 200mg/litre, it is recommended that a proprietary scale reducer is fitted in the cold water supply to the boiler. Check the total water "hardness", using the kit supplied, in the door, following the instructions given. Consult the local water company for additional advice.

A double check valve assembly must be fitted upstream of the scale reducer. For the relative position of the scale reducer and pressure reducing valve, if required, refer to the manufacturer's instructions.

## 6 Installation Preparation

### 6.1 Unpacking

Remove the top carton and cut out the flue template from the inner flap.

Open the control door, see diagram 6.1.

Remove the two screws securing the outer case and then lift it at the top and pull it forwards and off.

Remove the cover of the inner case, secured with four screws, see diagram 6.2.

Disconnect the gas service cock union and the front unions of the isolation valves, see diagram 6.3.

Slightly loosen the clips of the gas service cock and the isolating valves.

Remove the two boiler securing screws then remove the boiler from the mounting frame, by pulling the studs from the clips and unhooking it at the top.

### 6.2 Marking

The boiler mounting frame is the same width as the boiler but the flue connection sticks out above it.

Place the boiler mounting frame on the wall in the required position, see diagram 2.1 to maintain minimum clearances. Make sure that the isolation valves are at the bottom facing forwards and that the frame top is horizontal, then mark the four wall fixing points through the holes in the two horizontal straps.

Position the flue template on the wall, the arrow points on the centres of the two upper fixing points previously marked, see diagram 6.4 which also shows dimensions.

For rear flue, mark the rear flue position as required, centre and/or diameter.

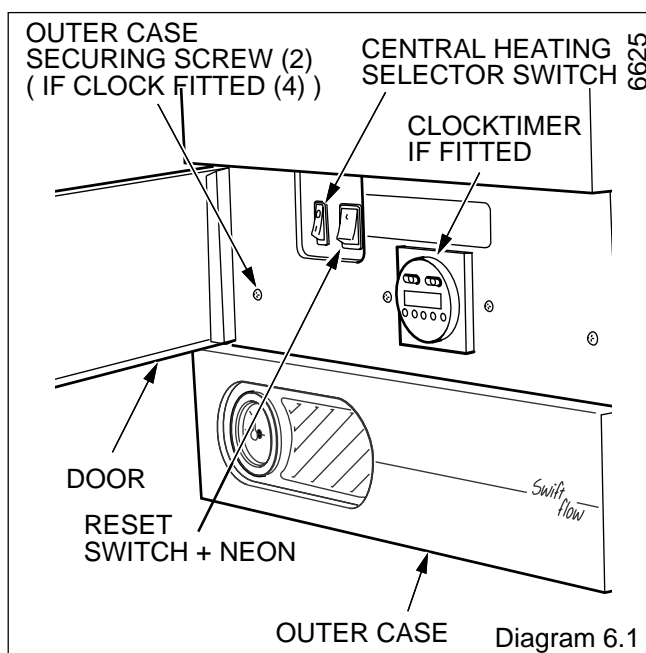

## 6 Installation Preparation

For a side flue, mark the horizontal flue centre line at the sides of the template. Extend the flue centre line horizontally left or right to the internal corner where the flue is required to exit to outside. Mark the position of the circular hole, on the flue exit wall, using the dimensions given in diagram 6.5.

From the flue position marks, check that the flue terminal will be in a suitable position, see diagram 3.6.

### 6.3 Flue Hole Cutting

Cut the hole horizontally in the wall, to the diameter shown in diagram 6.4, using, preferably, a core drill.

### 6.4 Wall Sleeve

Note: If required, an optional Wall Sleeve Kit, Part No. 900862, is available, complete with fixing instructions.

### 6.5 Boiler Mounting Frame Fixing

Position the flue template over the flue hole and check the position of the wall fixing points. Mark the position of the fixing holes again, if required.

Drill the four fixing holes and insert wall plugs to suit No.10x50mm long screws.

Secure the boiler mounting frame to the wall using No.10x50mm long screws.

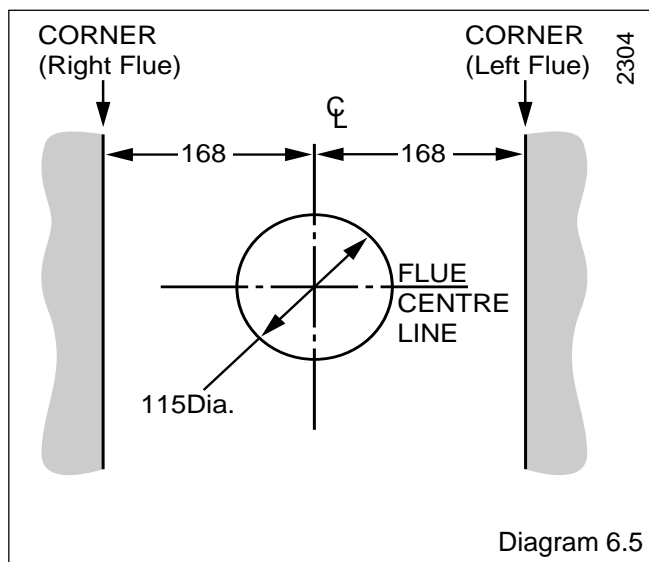
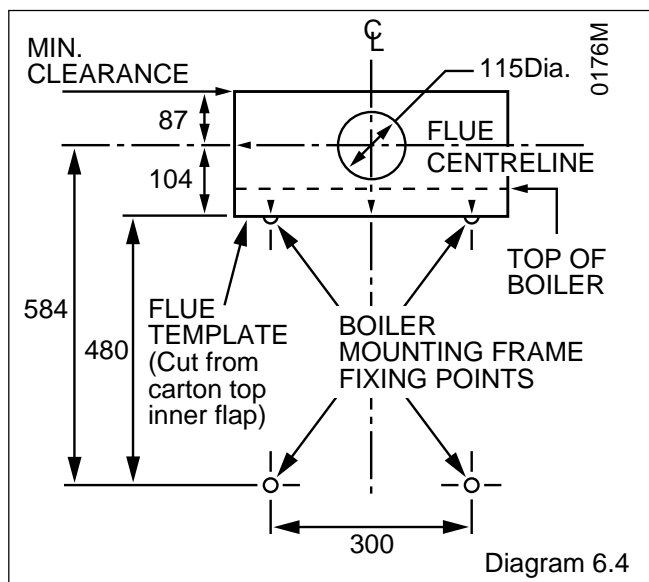
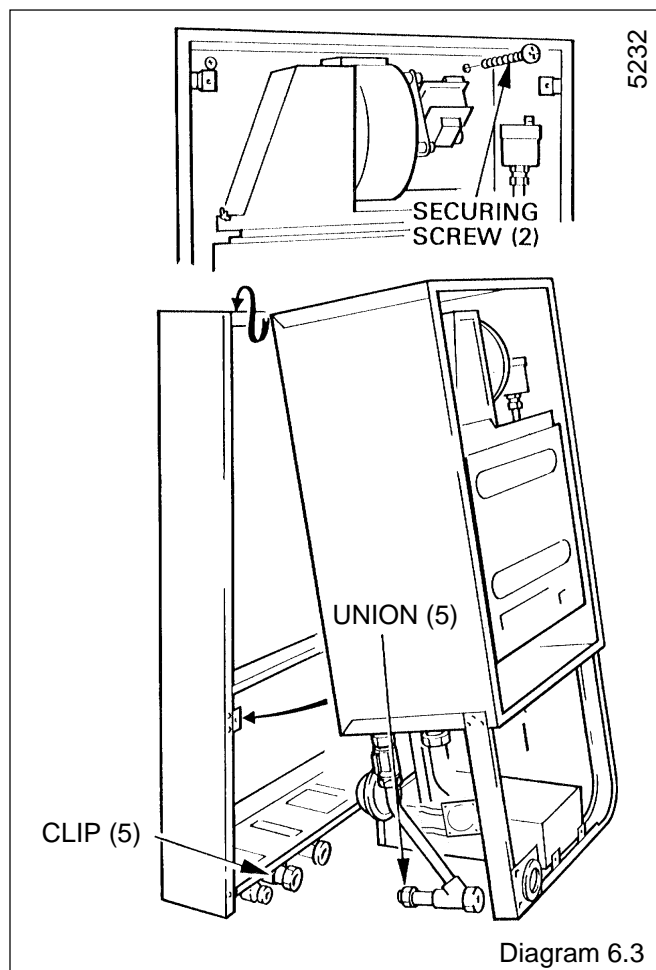
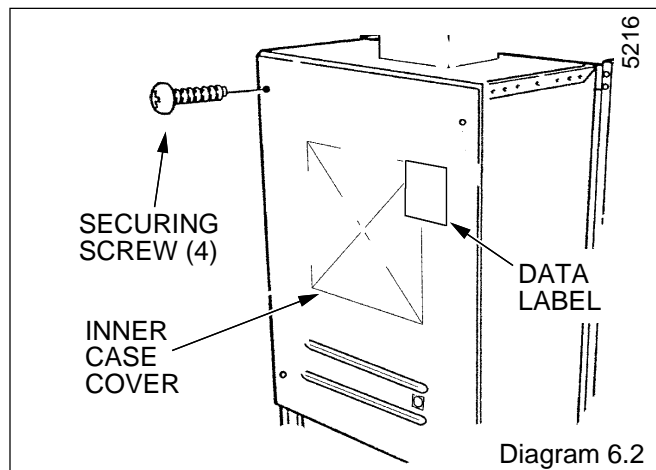

## 7 Flue Preparation

### 7.1 Flue Length

For a rear flue, measure the distance from the outside wall face to the boiler mounting wall. Check that the flue length will be suitable, see diagram 3.1 for a standard flue system or diagram 3.3 for a 1, 2 or 3 metre flue system.

For a side flue, measure the distance from the outside wall face to the side of the boiler mounting frame. Check that the flue length will be suitable, see diagram 3.2 for a standard flue system or diagram 3.4 for a 1, 2 or 3 metre flue system.

All flue systems are installed in a similar manner to the standard flue.

### 7.2 Rear Flue

Mark the air duct assembly and the flue duct at the lengths shown in diagram 7.1 and 7.2, then cut to length, cutting square and removing any burrs.

### 7.3 Side Flue

Mark the air duct assembly and the flue duct at the lengths shown in diagram 7.1 and 7.3 then cut to length, cutting square and removing any burrs.

### 7.4 Air Duct

Locate the flue duct and air duct in the flue elbow, making sure that the flue duct is located in the flue terminal and the flue elbow but is free to move to allow for expansion.

Check that the flue terminal is in the correct position and sticking out the correct distance from the outside wall face, see diagram 7.1 and appropriate diagram 7.2 or 7.3.

Drill a hole, diameter as shown in diagram 7.4, in each side of the air duct, through the holes in the flue elbow. Secure the air duct to the flue elbow using the two screws supplied in the loose items pack.

Seal around the joint between the air duct and the flue elbow using the tape provided in the loose items pack.

Stick the self-adhesive seal, supplied in the flue pack, around the air duct, in a position so that it will be flush with the outside wall when installed, see diagram 7.5.

If the boiler is not to be fitted for some time, cover the hole in the wall

### 7.5 Internal Access Flue

If access to the outside wall surface is not practical, the flue system can be installed from inside. Use of the optional wall sleeve kit is recommended, see diagram 7.5.

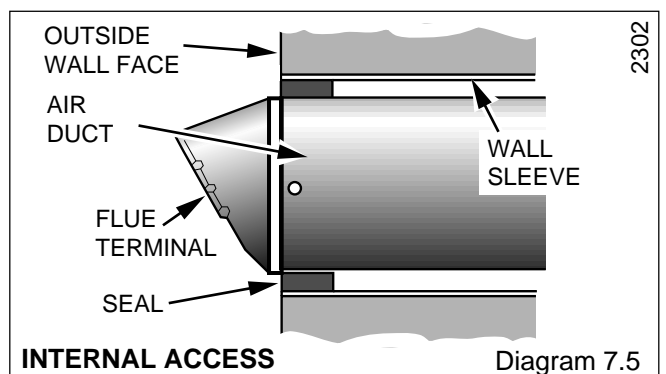
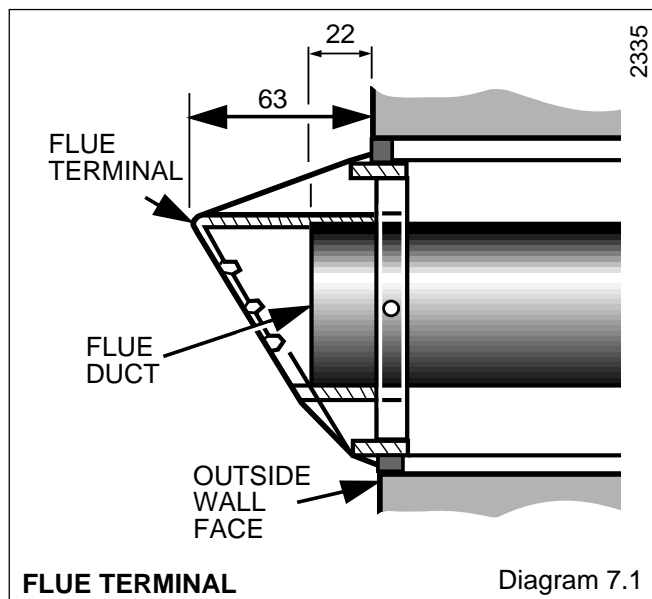
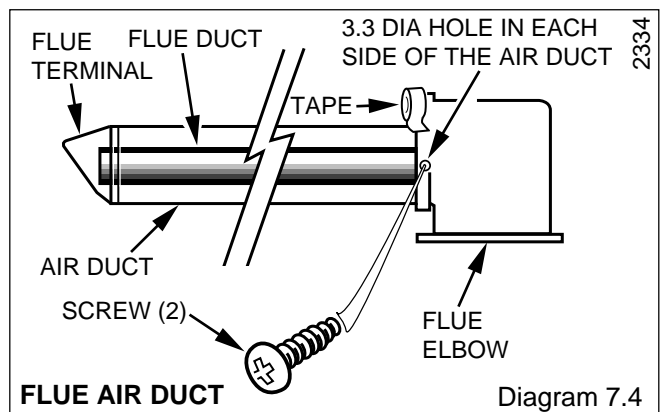
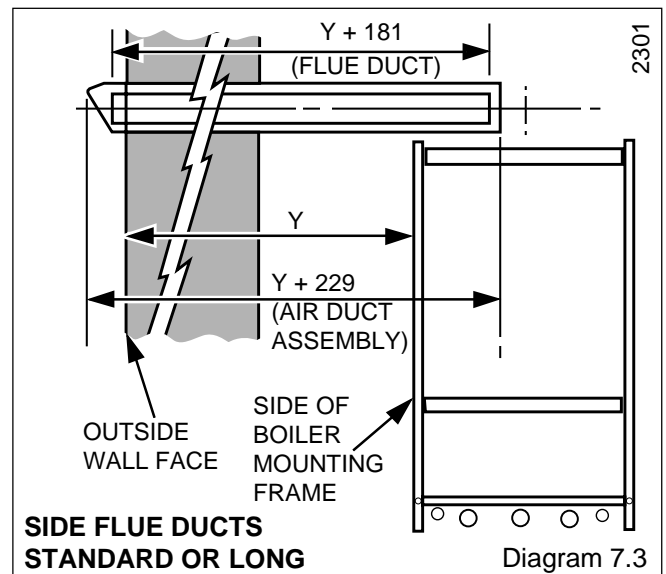
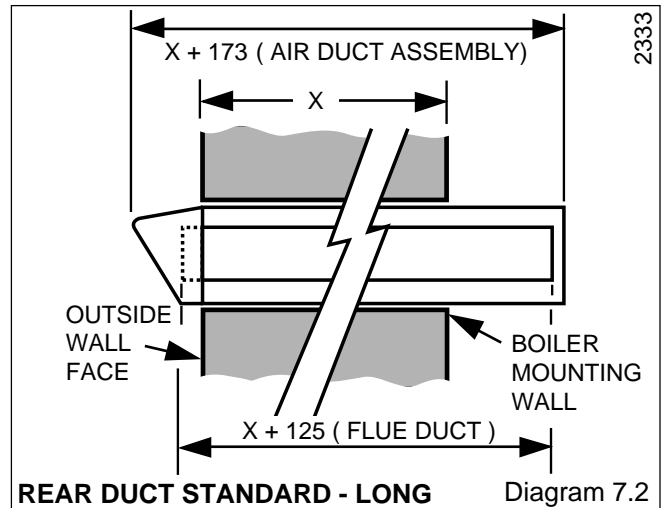



## 8 Gas and Water Connections

### 8.1 Gas Connection

Provision is made for the gas supply to be connected from below or through the wall at the rear of the boiler, see diagram 8.1 for position.

Refer also to "Gas Supply", Section 1.7.

Make the gas supply connection to the gas service cock. Slacken or remove the clip, as preferred, while making the connection. Do not subject the gas service cock to heat as you may damage the seals.

### 8.2 Water Connections

Provision is made for the domestic cold water inlet to be connected from below or through an internal wall at the rear of the boiler, see diagram 8.1 for position. Refer also to Section 5 "Domestic Hot Water System".

Provision is made for the domestic hot outlet, heating flow and return to be connected from below, through an internal wall at the rear of the boiler or from above, passing down either side of the boiler, see diagram 8.2 for clearances. Take care that any pipework connected from above, within the boiler mounting frame will clear the expansion vessels.

If necessary, temporarily fit the boiler, refer to Section 10.1, "Mounting the Boiler".

Flush out the domestic water and heating system before connecting the boiler.

Make the connections to the domestic hot water outlet and the heating system by means of the isolating valves, see diagram 8.1.

Slacken or remove the clips, as preferred, while making the connections. Do not subject any of the isolating valves to heat as you may damage the seals.

Make sure that the drain points on the isolating valves are positioned towards the front of the boiler, also that the drain and operating screw heads are accessible.

### 8.3 Safety Valve Discharge

**WARNING.** It must not discharge above an entrance or window or any type of public access area.

A short discharge pipe is supplied loose with the boiler, which when fitted to the safety valve, will end below the boiler at the mark between the cold water inlet and the heating flow, for position and dimension see diagram 8.1.

This must be extended, using not less than 15mm od pipe, to discharge, in a visible position, outside the building, facing downwards, preferably over a drain. The pipe must have a continuous fall and be routed to a position so that any discharge of water, possibly boiling, or steam cannot create any danger to persons, damage to property or external electrical components and wiring.

Note. To ease future servicing it is advisable to use a compression type fitting to extend the discharge pipe.

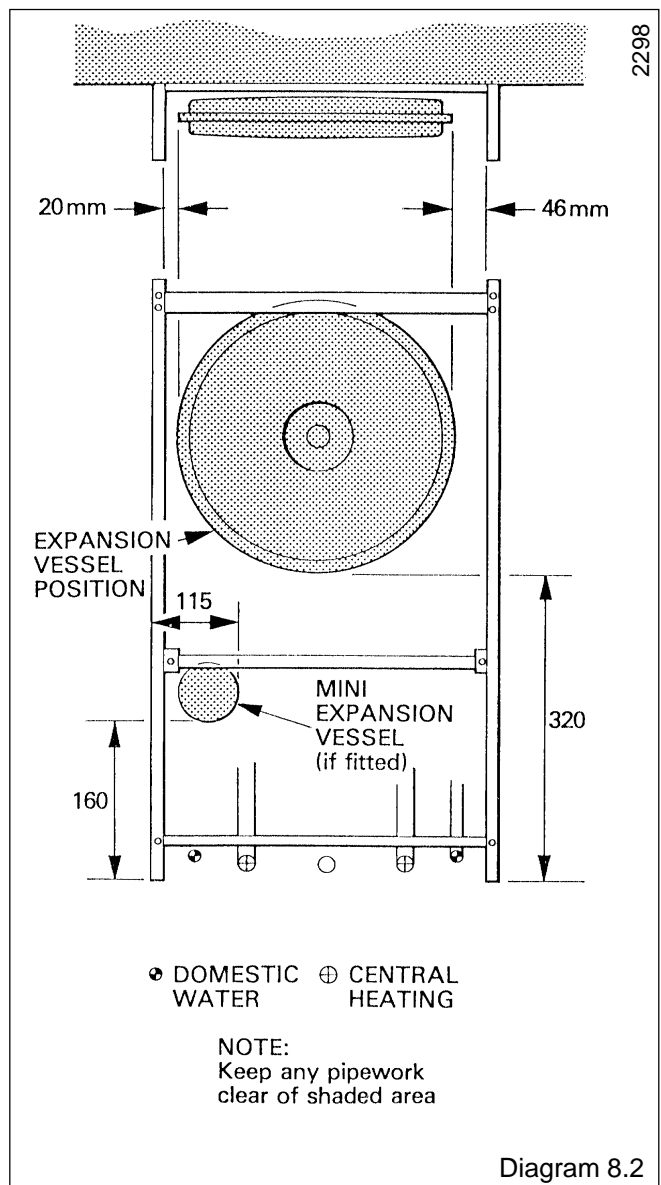
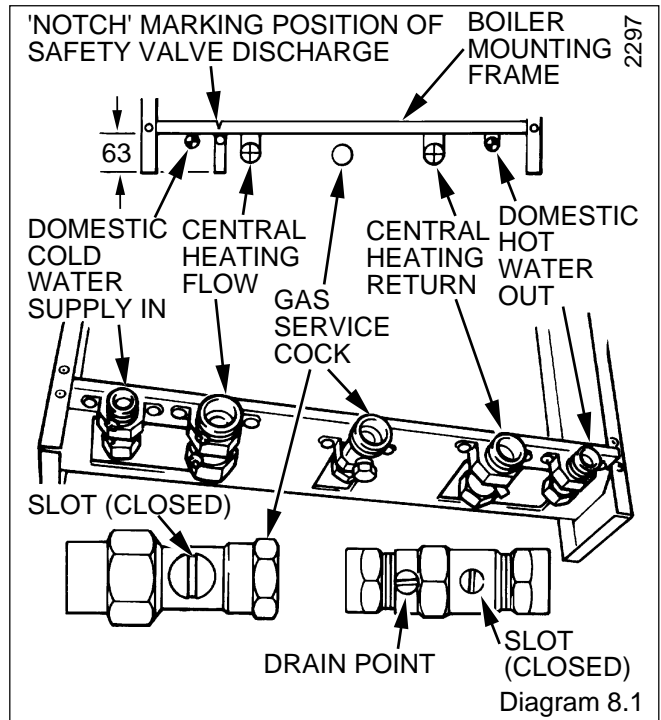

## 9 Electrical Connections

### 9.1 Supply Cable Connection

**CAUTION:** To prevent an induced current from switching the central heating on, when not required, it is important that the heating system control cables are separated from the other mains supply cables.

The boiler requires a permanent mains supply through an external isolator which must also isolate any heating system controls, see diagram 9.2.

Any heating system controls must not interrupt the permanent mains supply to the boiler.

Remove the electrical connector from the loose items pack.

Remove the two screws and cover from the connector, see diagram 9.1.

Using PVC cable of a suitable length and rating as stated in Section 1.8 "Electrical Supply", connect the mains supply cable to the appropriate terminals of the connector, see diagram 9.2.

Standard colours are, Brown - Live, Blue - Neutral, Green and Yellow - Earth.

The mains cable outer insulation must not be cut back external to the plug, see diagram 9.1.

Make the earth cable of a greater length so that if the cable is strained the earth would be the last to become disconnected.

**CAUTION:** It is ESSENTIAL to make sure that the polarity is correct.

### 9.2 Heating System Controls

**CAUTION:** To prevent an induced current from switching the central heating on, when not required, it is important that the heating system control cables are separated from the other mains supply cables.

The heating system should have installed: a programmer and room thermostat controlling the boiler.

Thermostatic radiator valves may be installed in addition to the room thermostat.

Note: For further information, see The Building Regulations 1991 - Conservation of fuel and power, 1995 edition - Appendix G, table 4b.

If electrical controls are not to be used to regulate the heating system, do not disturb the red link cable.

When any form of electrical control is being used to regulate the heating system, remove the red link cable and connect heating system controls in series.

The mains cable outer insulation must not be cut back external to the plug.

### 9.3 Clock/Timer Kit

An internal clock/timer kit can be supplied, refer to the literature supplied with it.

### 9.4 Frost Thermostat

If the installation requires protection by a "frost thermostat", connect a single pole type, to the appropriate terminals of the connector.

### 9.5 Cable and Connector Securing

After completing all the connections to the boiler, secure the cable(s) with the cover, using the two screws previously removed, see diagram 9.1.

Clip the connector into position with the cable(s) at the back.

Secure all cables in the clamp immediately behind the connector.

If necessary also secure cables to the wall, using suitable cable clips.

Keep all cables away from hot surfaces.

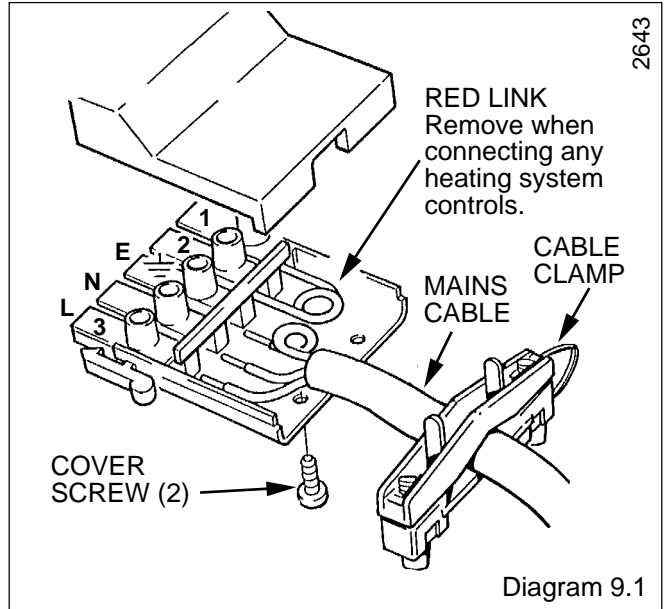

# 9 Electrical Connections

5217

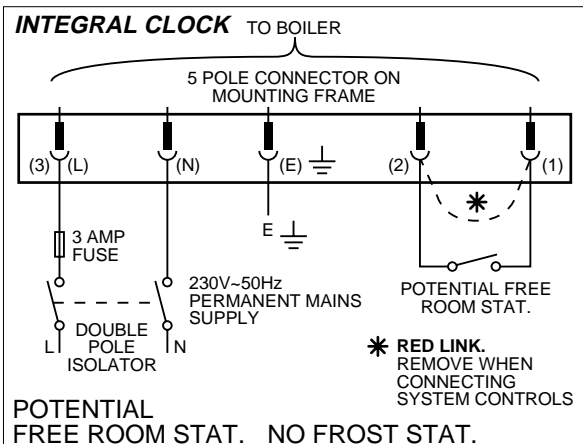
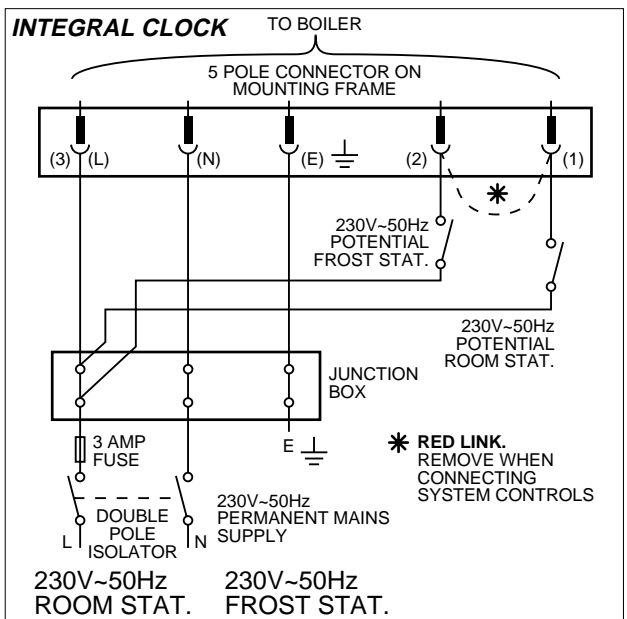
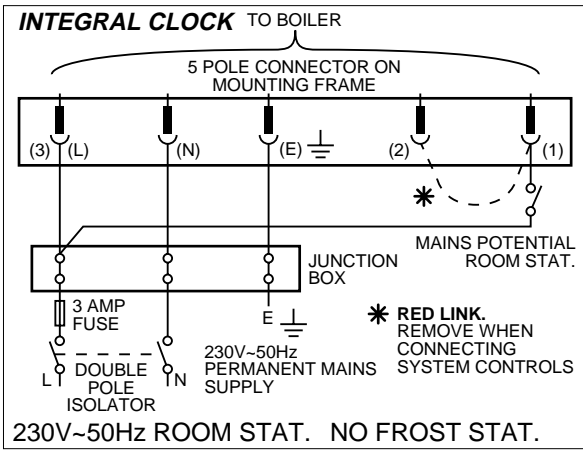
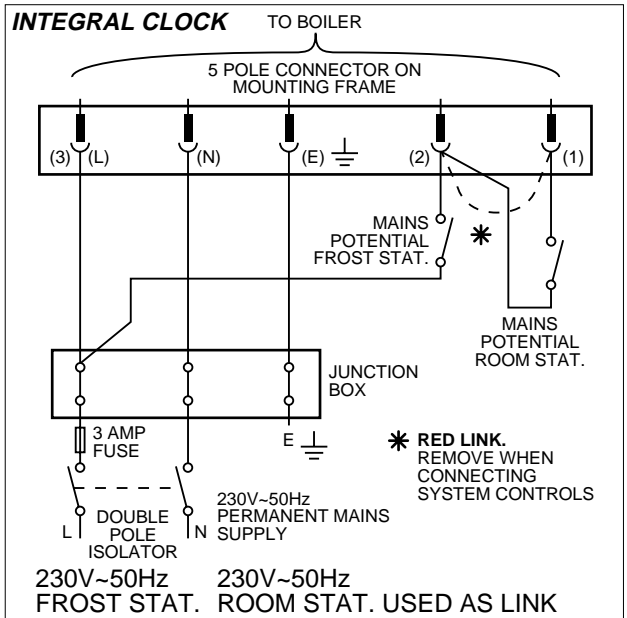
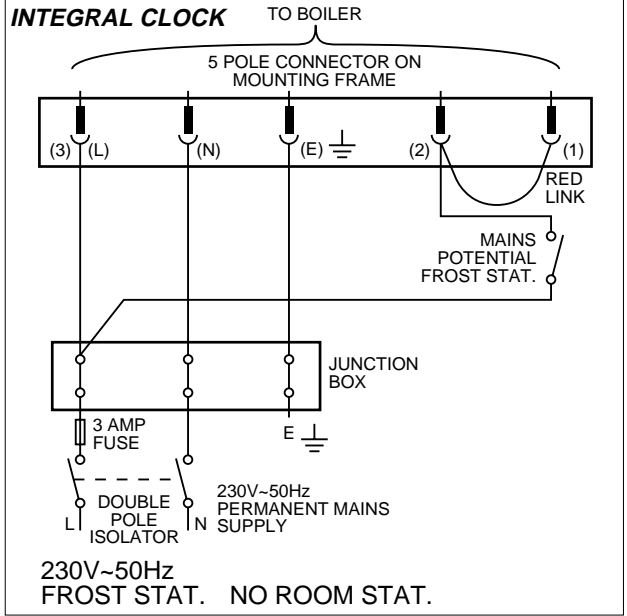
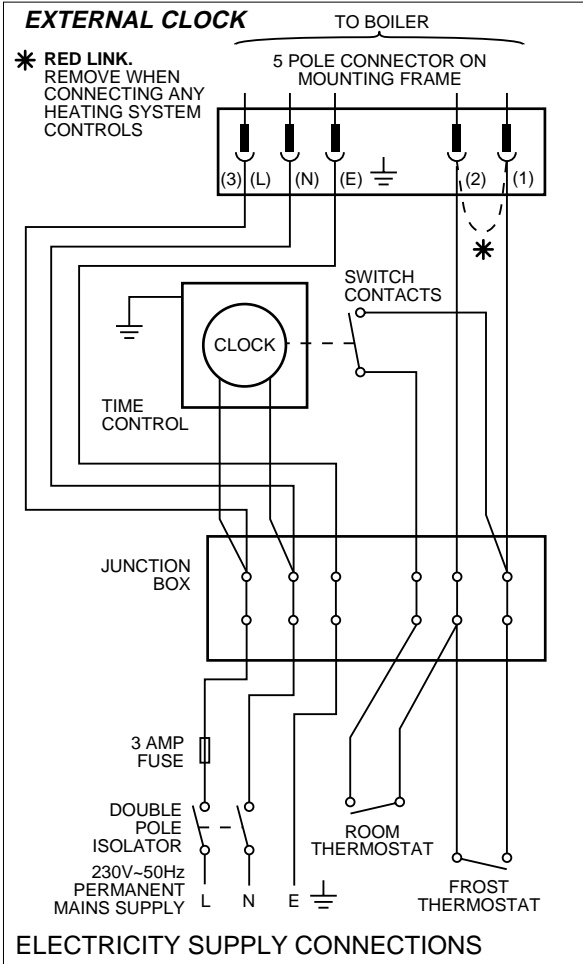

Diagram 9.2

## 10 Boiler Fixing

### 10.1 Mounting the Boiler

After installing the boiler mounting frame, domestic and heating water systems, making the electrical connections and preparing the flue components, carry on as below:

Lift the boiler into position, hooking it on the boiler mounting frame at the top, then loosely fit the two boiler securing screws at the top, see diagram 6.3.

### 10.2 Gas and Water Connections

Locate the boiler water pipes into the isolation valves and the gas service cock union halves. Fully push the boiler back to the mounting frame, locating the studs into the clips.

Make the compression joint on the isolating valves and join the gas service cock union. Secure all of the valves and gas service cock with the clips.

### 10.3 Boiler Securing

Secure the boiler by tightening the two boiler securing screws at the top.

### 10.4 Discharge Pipe

Remove the two control housing securing screws, see diagram 10.1.

Remove the control housing and support the control housing on a surface or by screwing it to the front edge of the base, using one of the securing screws, see diagram 10.1.

If required, to improve access, the air pressure switch can be removed, refer to the service instructions, section 4.31.

Fit the short discharge pipe to the safety valve using the nut and olive supplied loose, see diagram 10.2.

Extend the discharge pipe, using only a compression type fitting to join the discharge extension, refer also to Section 8.3 "Safety Valve Discharge".

### 10.5 Clock/timer Kit (if applicable)

Fit the clock/timer kit following the appropriate sections of the instructions supplied with it.

### 10.6 Electrical Connector

Connect the two halves of the electrical connector together.

Clip the connector into position on the boiler mounting frame. Secure the cables with cable clamp immediately behind the connector.

Carry out preliminary electrical system checks as below:

1. Test insulation resistance to earth of mains cables.
2. Test earth continuity and short circuit of all cables
3. Test the polarity of the mains.

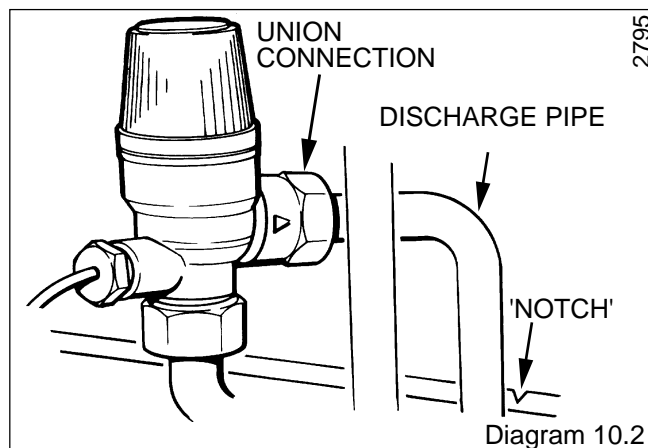
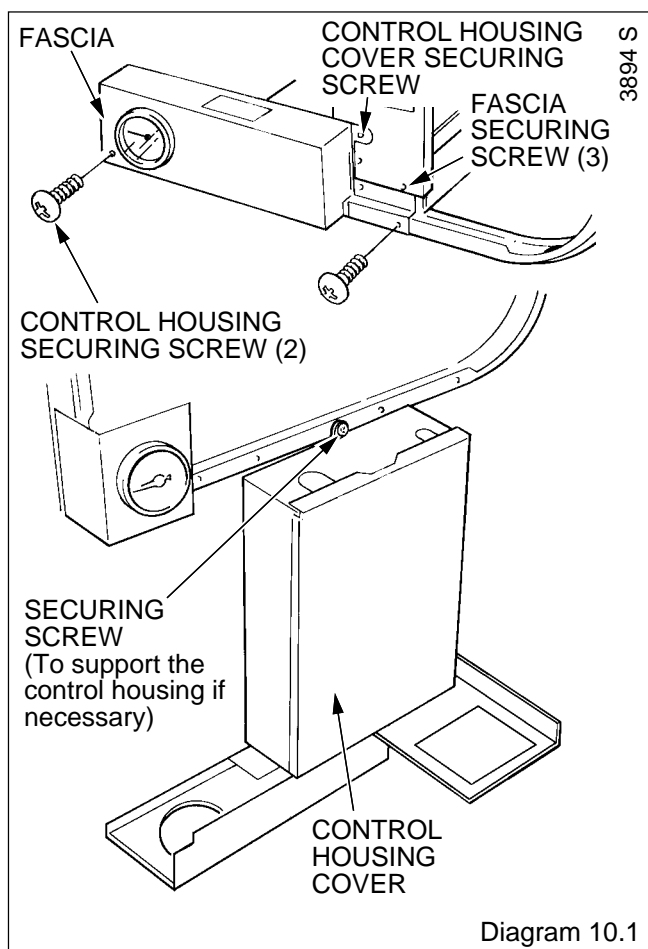

## 10 Boiler Fixing

### 10.7 Flue Fixing

Fit the self-adhesive gasket, supplied in the loose items pack, to the flue elbow, see diagram 10.3.

Push the prepared ductings into and through the wall sleeve, the longest protrusion of the flue terminal is positioned at the top.

Note: The foam seal is a tight fit in the wall sleeve and the flue system should not be inserted unless the cement has fully set or it can be held from the other side.

Fit the flue elbow to the top of the boiler, see diagram 10.3, using the four screws supplied loose. To assist with the location of the flue elbow into the fan outlet, loosen the two wing nuts on the flue collector angle and the two fan securing screws.

Tighten the four screws of the flue elbow evenly to ensure a good seal at the gasket. Tighten the wing nuts and screws, if slackened, to secure the flue collector and fan.

Make the wall good internally around the air duct.

Check that the ductings do not slope down towards the boiler.

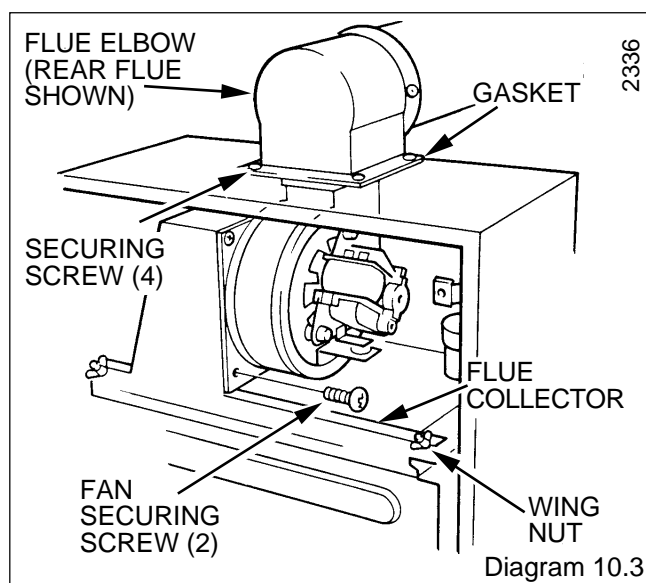

## 11 Commissioning

### 11.1 Filling Domestic Water Circuit

Check that the boiler is isolated from the electrical supply, at the external isolator.

Fully open the domestic water supply stop cock or valve in the supply to the boiler.

Open the two domestic water isolation valves, slots in line with the length of the valve, see diagram 8.1.

Open all hot water draw-off taps and close them when water flows. Check for water soundness of the whole domestic water system and boiler.

### 11.2 Filling the Heating System

It is essential that a bypass is fitted in all installations, 22mm o.d. minimum. The bypass must have a lockable valves "B" in diagram 4.2, incorporated in a position so that inadvertent closure or unauthorised interference is not possible.

The bypass MUST be fitted before any system control. A radiator bypass is not recommended.

Open the two central heating isolating valves, slots in line with the length of the valve, see diagram 8.1.

Flush, fill and vent the system refer to Section 4.9 "Filling Sealed Systems".

**WARNING. SEVERAL COMPONENTS OPERATE ON MAINS VOLTAGE AND WITH THE OUTER CASE REMOVED, LIVE COMPONENTS BECOME EXPOSED.**

To assist in filling and venting, the pump may be operated: Connect the electrical supply, set switch "C" to "On", any remote heating systems controls, time switch and/or room thermostat to call for heat, see diagram 11.1.

Note. If the clock/timer kit is to be fitted, refer to the setting instructions in the Instructions for Use.

Make sure that the automatic air vent is operating correctly, see diagram 11.2.

Take care not to splash any of the electrical components.

Alternate the position of switch "C" between "On" and "Off" positions to ensure that water flows through all parts of the boiler and air is not trapped in the boiler internal bypass.

Pressurise the system until the pressure is 1.5bar (21.5lbf/in<sup>2</sup>). Check the heating system and boiler for water soundness.

Check the operation of the safety valve by turning the safety valve knob in the direction of the arrow.

Lower the pressure to the initial cold fill design pressure, refer to Section 1.6 "Data". Position the set pointer on the boiler pressure gauge at this pressure also.

### 11.3 Preparation for Lighting

Isolate the boiler from the mains electrical supply at the external isolator.

Test for soundness and purge air from the gas supply. Turn on the gas service cock, slot in line with the length of the cock.

Loosen the burner pressure test point screw and connect a suitable pressure gauge, see diagram 11.3.

### 11.4 Burner Pressure - Hot Water

The burner pressure is factory preset and no adjustment should be required.

Connect the electrical supply; the pump will operate for about 30 seconds, then the pump will stop.

Fully open the largest hot water draw off tap whereby the main burner will light, the flames gradually increasing to the maximum.

Check the soundness of the boiler gas joints, with the main burner on, using a leak detection fluid. Take care not to splash any of the electrical components.

Fully open the hot water throttle, (clockwise), see diagram 11.5. Check that the water flow rate is not less than: 10.5 l/min (2.3 g/min), equivalent to 5.7 seconds to fill a 1 litre container, or 3.3 seconds to fill a 1 pint container.

To achieve this flow rate a water pressure of at least 0.8bar is required during commissioning, although subsequently the appliance will work at a minimum pressure of 0.5bar.

This flow rate should prevent any modulation of the gas pressure.

## 11 Commissioning

Check the burner pressure is within  $\pm 0.35\text{mbar}$  ( $\pm 0.14\text{in wg}$ ) of  $15.6\text{mbar}$  ( $6.3\text{in wg}$ ). If this is incorrect, the burner pressure may be adjusted to the correct setting by turning the hot water gas pressure adjuster (potentiometer), using an insulated screwdriver, see diagram 11.4. Gain access to the adjusters on the control board by removing the control housing cover, see diagram 10.1. Turn the adjuster slowly, always making adjustment by reducing below the required pressure then increasing up to the required setting, (turn clockwise to increase).

Close the hot water draw off.

If the maximum pressure cannot be obtained, check that the gas supply of adequate size, refer to Section 1.7.

### 11.5 Gas Rate Modulation

The minimum gas rate is factory preset and no adjustment should be required.

**ALWAYS CHECK HOT WATER BURNER PRESSURE FIRST - REFER TO SECTION 11.4.**

To check the minimum gas rate, first make sure that the boiler is isolated from the electrical supply at the external isolator. Disconnect one of the electrical connectors (grey), from the modulator, see diagram 11.3.

Insulate the connector to make sure that it does not contact any metallic part of the boiler.

Switch on the electrical supply.

Fully open a hot water draw off tap and the main burner will light at the minimum gas rate.

Check that the burner pressure is  $2.4\text{mbar} \pm 0.2\text{mbar}$ , ( $1.0\text{in wg} \pm 0.1\text{in wg}$ ). If this is incorrect, it may be adjusted by removing the cap and turning the larger adjusting nut of the modulator, (anti-clockwise to decrease the pressure).

If the above adjustment was necessary, it will be essential to check that the maximum pressure can still be obtained. Push the spindle gently in to the stop and hold it in. The maximum pressure should not be less than  $16.1\text{mbar}$ , ( $6.5\text{in wg}$ ). If this pressure cannot be achieved, obtain it by turning the small adjusting nut, (clockwise to increase the pressure). Always adjust the minimum pressure first.

If the maximum pressure is unattainable, check that the gas supply is of adequate size, refer to Section 1.7 "Gas Supply". Put right as necessary.

Isolate the boiler from the electrical supply then reconnect the modulator cable and refit the cap.

### 11.6 Domestic Water Flow Rate

Adjust the water throttle to obtain a flow rate of:  $9.0\text{ L/min}$  ( $2.0\text{ gall/min}$ ), equivalent to 6.7 seconds to fill a 1 litre container, or 3.8 seconds to fill a 1 pint container.

Close the tap when adjustment is satisfactory.

The minimum water flow rate is  $3.6\text{ Litre/min}$  ( $0.8\text{ gall/min}$ ) equivalent to 16.5 seconds to fill a 1 Litre container (9.5 seconds to fill a 1 pint container). If this flow rate cannot be achieved, check that there is no partial blockage and that the supply is of adequate size. Put right as necessary.

Close the hot water draw off tap.

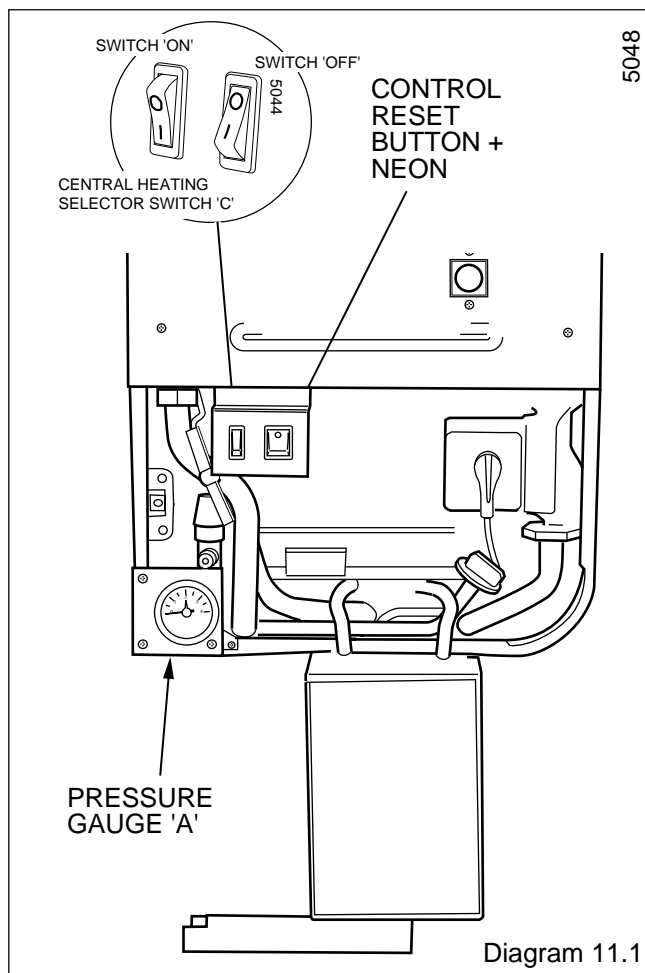

Diagram 11.1

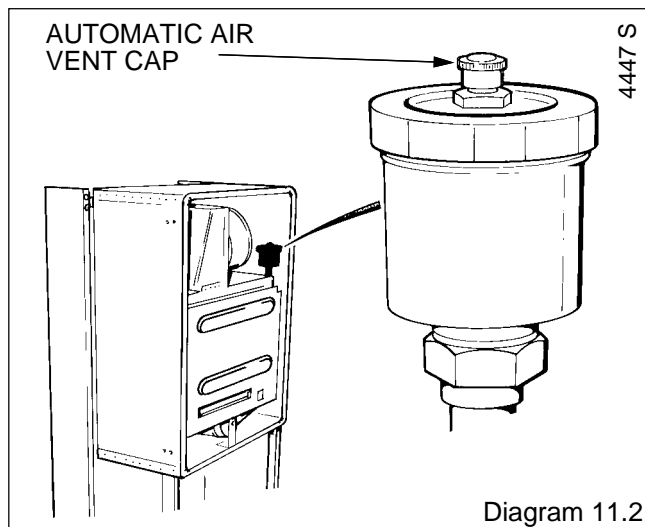

Diagram 11.2

# 11 Commissioning

## 11.7 Burner Pressure - Heating

The burner pressure is factory preset and no adjustment should be required.

Check that all remote heating system controls, room thermostats, integral clock and the like are switched on/programmed and calling for heat.

Set switch "C" to "On" as shown in diagram 11.1.

The pump will circulate water through the boiler and the main burner will light.

Check that the burner pressure, with the heating system cold to prevent any modulation of the gas pressure, is within +/- 0.2mbar (+/-0.08in wg) of 8.0mbar (3.4in wg), the central heating pressure.

If the burner pressure is incorrect, it may be adjusted to the correct setting by turning the central heating gas pressure adjuster (potentiometer), using an insulated screwdriver, see diagram 11.4. Turn the adjuster slowly, always making adjustment by reducing below the required pressure then increasing up to the required setting, (turn clockwise to increase).

Isolate the boiler from the electrical supply.

Remove the pressure gauge and tighten the test point screw.

Fit the cover and secure the control housing with the screws previously removed.

Test for gas soundness around the burner pressure test point with the main burner alight, using leak detection fluid. Take care not to splash any of electrical components.

## 11.8 Temperature Settings

The domestic hot water outlet and central heating flow temperatures are factory preset and sealed, therefore cannot be adjusted.

The nominal temperature setting for the domestic hot water outlet is 55°C (131°F) at a flow rate of 3.6Litre/min (0.8gall/min).

The nominal maximum flow temperature setting for central heating is 82°C (180°F).

## 11.9 Heating System - Commissioning

Check that all remote controls and integral clock are calling for heat.

Fully open all radiator valves, flow control valve "A" and bypass valve "B", see diagram 4.2.

Set the heating system in operation and balance the radiators.

Adjust the control valve "A" to achieve the required system differential temperature between the flow and return.

Turn off all radiators, then adjust bypass valve "B" to achieve the same temperature difference between the boiler flow and return.

Refer to Section 4.6 and diagram 4.1 and 4.1A.

Allow the system to reach maximum temperature then switch off, isolate the boiler from the electrical supply and drain the system rapidly whilst still hot.

Fill and vent the system as described in Section 11.2 "Filling the Central Heating Circuit". Add inhibitor, if applicable, refer to Section 4.10 "Inhibitor".

Lower the pressure to the initial cold fill design pressure, using the external draining tap, close to the boiler, refer Table 2 and Section 4.11.

Lock or remove the handles from the spindles of flow control valve "A" and bypass valve "B" to prevent unauthorised adjustment.

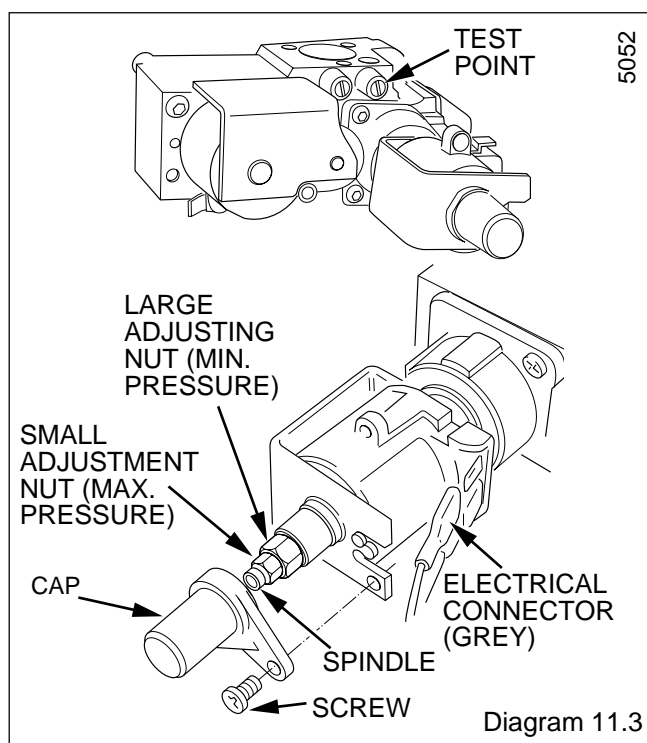

Diagram 11.3

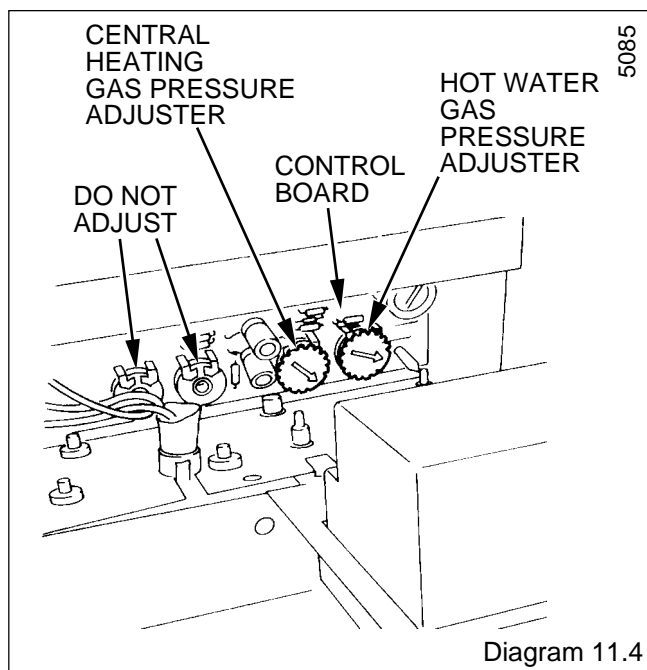

Diagram 11.4

## 11.10 Completion

The user control door is designed for left or right hand hinging. If required the hinge can be moved to the other side to that supplied, as follows:

Remove the hinge pin bracket securing screw then remove the hinge pin retaining bracket and holding the door, remove the hinge pin. Prise out the hinge pin bushes and fit on to the opposite side of the door, see diagram 11.6.

Remove the screw and nut and fit to the opposite side of the case. After removing the hinge pin retaining bracket refit the door and hinge pin. Refit the hinge pin retaining bracket and fit the securing screw.

Fit the catch assembly, supplied in the loose items pack, see diagram 11.6.

# 11 Commissioning

If required, fit the plastic covers to hide the bracket securing screws.

Change the position of the "Push" label to suit the new door opening.

Clock/timer, if fitted, remove the screws, nuts and washers to release the cover plate, see diagram 11.6.

Stick the casing label to the right hand side of the clock/timer.

Fit the outer case, secure with the four screws, see diagram 11.6.

Note: Secure with the two outer screws only if there is no clock/timer fitted.

Set the boiler and any remote heating control to the desired settings, then close the door.

## 11.11 Instruct the User

Instruct and demonstrate the lighting procedure, then advise the user of the efficient and safe operation of the boiler.

Instruct and demonstrate the operation of any heating system controls.

Advise the user on the use and maintenance of any scale reducer and pass on any relevant instructional documents.

Advise the user that to ensure the continued efficient and safe operation of the appliance it is recommended that it is checked and serviced at regular intervals. The frequency of servicing will depend upon the particular installation and usage, but in general once a year should be enough.

Draw attention, if applicable, to the current issue of the Gas Safety (Installation and Use) Regulations, Section 35, which imposes a duty of care on all persons who let out any property containing a gas appliance.

It is the Law that any servicing is carried out by a competent person.

Advise the user of the precautions necessary to prevent damage to the system and building in the event of the heating system being out of use during frost and freezing conditions.

Reminder - Leave these instructions with the user.

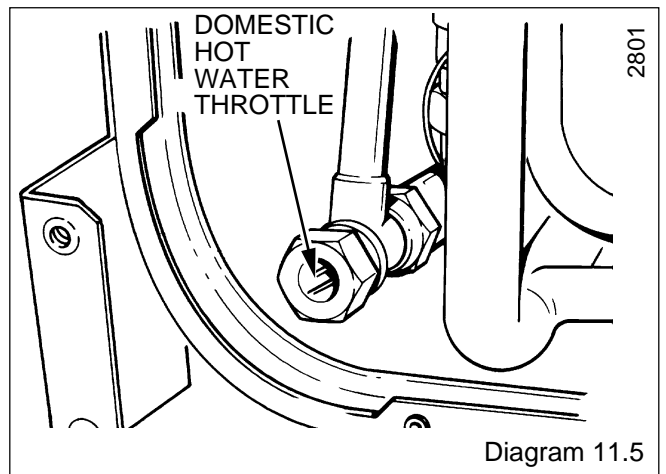

Diagram 11.5

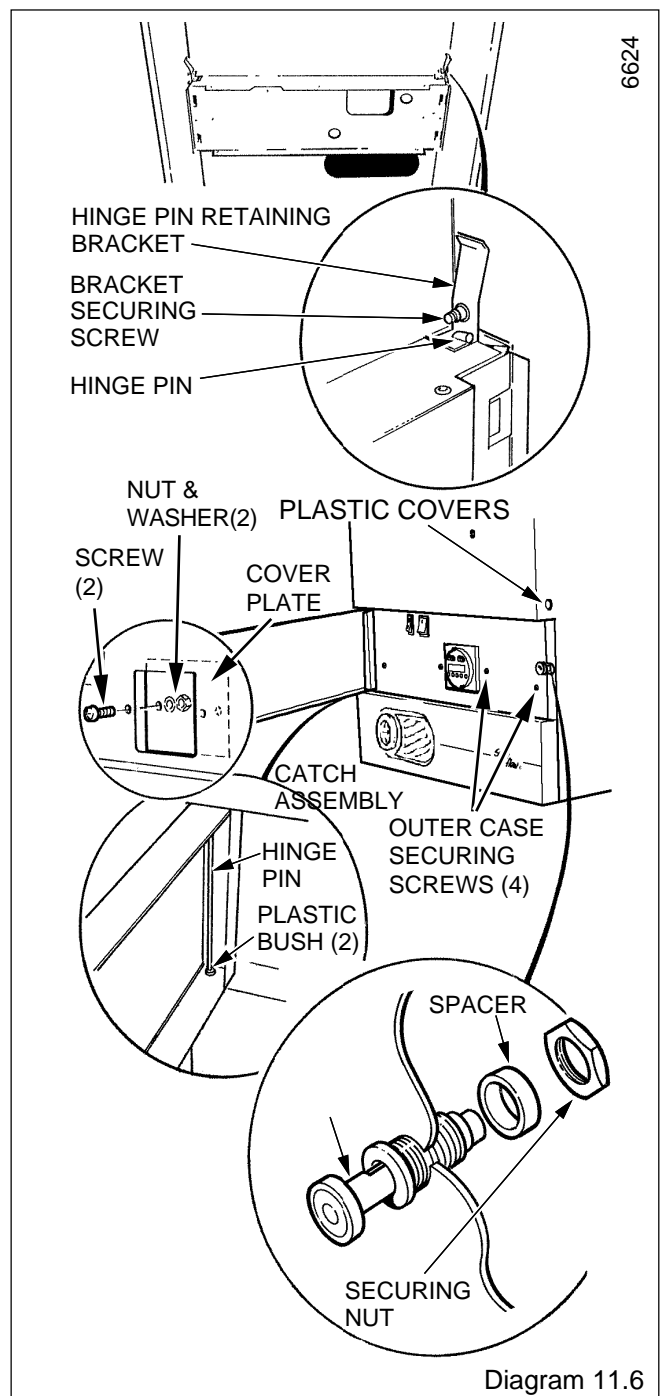

Diagram 11.6



# 1 General Data

## 1.1 Servicing or Replacing Parts

To ensure the continued efficient and safe operation of the boiler it is recommended that it is checked and serviced as necessary at regular intervals.

The frequency of servicing will depend upon the particular installation conditions and usage, but in general once a year should be enough.

The servicing of this boiler must be carried out by a competent person in accordance with the rules in force in the countries of destination.

NOTE: To obtain a products of combustion reading, remove the outer case see diagram 6.1 Installation Instructions. Disconnect the clear upper tube from the air pressure switch, see diagram 1.2 and 4.28, insert the analyser probe into the tube.

Typical values for this boiler at maximum domestic hot water demand is:- CO<sub>2</sub> 6.5% to 7.5% and CO 0.003% to 0.013%. These are based on a 300mm length rear flue.

Make sure the appliance does not modulate whilst checking combustion and allow the appliance to warm up for five minutes before taking a reading.

Unless stated otherwise, parts removed or renewed during servicing should be fitted in the reverse order to removal.

After completing any servicing, or renewing of gas carrying components, ALWAYS test for gas soundness and carry out functional checks of controls.

Throw away all used sealing washers, gaskets and "O" rings when renewing components.

Use the new ones supplied with the replacement.

## 1.2 Data Label

The data label is positioned on the front of the inner case cover, see diagram 1.2.

## 1.3 Isolation of Boiler

Before starting any servicing or the replacement of parts, isolate the boiler from the electrical supply at the external isolator and close the gas service cock, see diagram 1.1.

BEFORE DRAINING THE BOILER, REFER TO SECTION 1.6.

## 1.4 Outer Case Removal

The door opens to the left or right hand side. The door catch is spring loaded, to open, push the side opposite to the hinge then pull.

Remove the two screws securing the outer case then unhook the case at the top and pull it forwards and off, see diagram 6.1 Installation Instructions.

Note: Remove the four securing screws if there is a clock/timer fitted.

## 1.5 Cover - Inner Case

Remove the cover of the inner case, secured by four screws, see diagram 1.2.

## 1.6 System Pressures and Draining

All parts containing water of the central heating circuit within the boiler, are under the system pressure. Before any parts of this circuit are disconnected, reduce the system pressure at the external draining tap, turn the central heating isolating valves off, and drain at the drain points on the appropriate valves, see diagram 1.1.

All water containing parts of the domestic hot water circuit of the

boiler will be under the supply water pressure. Before any parts of this circuit are disconnected, turn the domestic cold water isolating valve off, open the hot water taps to reduce the water pressure in the boiler, close the hot water isolating valve and drain the boiler at the valves, see diagram 1.1.

After replacing any water containing part of the central heating circuit, make up the water loss, vent all air and pressurise the system. Refer to "Commissioning" in the Installation Instructions.

Check for water soundness and that the safety valve seats without leaking.

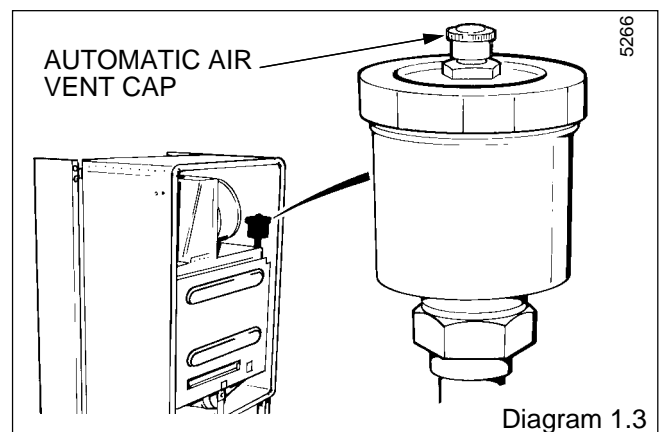
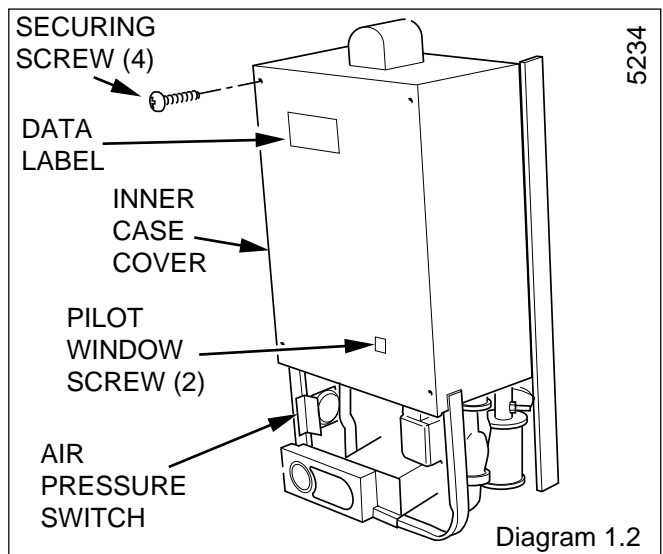
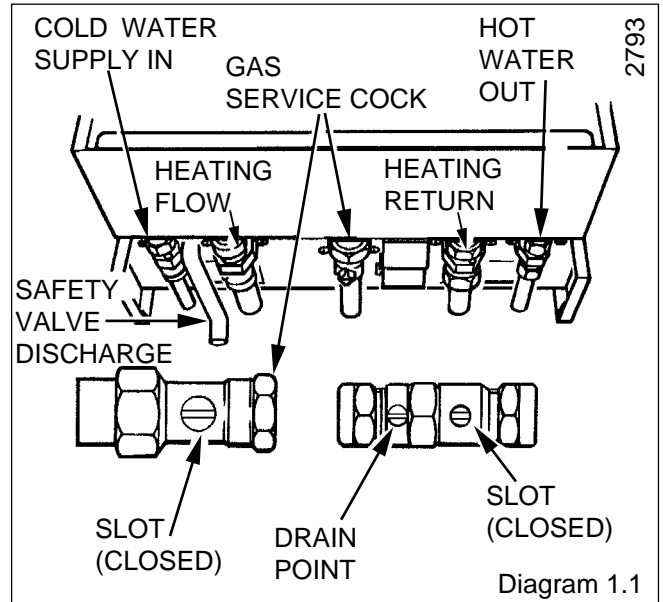

## 2 Servicing

### 2.1 Isolation and Access

Before commencing, refer to Section 1.1.

Isolate the boiler from the electrical supply and close the gas service cock, refer to Section 1.3.

Remove the outer case and the cover of the inner case, refer to Sections 1.4 and 1.5.

Remove the fan from the flue collector, refer to Section 4.1.

Remove the flue collector secured by two wing nuts and hook bolts, see diagram 4.1.

Remove the main burner, refer to Section 4.2.

### 2.2 Cleaning Heat Exchanger

Place a sheet of paper or similar in the combustion chamber, to act as a collector for deposits removed.

Brush the heat exchanger with a suitable brush, remove paper together with any debris.

Do not use a brush with metallic bristles.

### 2.3 Cleaning Main Burner

Use a vacuum cleaner or suitable brush to clean the burner thoroughly, making sure that all burner ports are clear and unobstructed.

Do not use a brush with metallic bristles.

### 2.4 Service Checks

Inspect the spark and sensing electrodes, Clean or renew if necessary, refer to Sections 4.4, 4.5, 4.6 and 4.7.

Check the main injector, cleaning or renewing as necessary, refer to Section 4.3.

Before replacing any of the parts removed during servicing, inspect the condition of all seals and joints, renewing them as necessary.

Check the condition of the combustion chamber insulation. If renewing, refer to Section 4.30.

Check that the spark and sensing gaps are as shown in diagram 2.1.

### 2.5 Initial Assembly

Make sure that the main burner is located on the main injector and is horizontal, the tips of the rearmost blade under the two burner guides.

The combustion chamber front panel should be fitted loosely, then the flue collector also fitted loosely, making sure that it is seated correctly on the heat exchanger and over the top edge of the front panel.

To fit the fan, locate it into the rear bracket and ease the flue elbow onto the fan outlet and secure with the two screws, see diagram 4.1.

When fitting the flexible tubes to the air pressure switch make sure the lower (red) tube from the fan connects to the lower connection of the switch.

Connect the electrical cables to the fan, the polarity of the two connectors is not important, see diagram 4.1.

Secure the flue collector and combustion chamber front panel by tightening the wing nuts and screws, evenly, see diagrams 4.1 and 4.2.

### 2.6 Operational Checks

Light the boiler, carry out operational checks and any necessary adjustments as described in "Commissioning" in the Installation Instructions.

### 2.7 Completion

Hook the outer case on at the top and secure with the screws previously removed, see diagram 6.1 Installation Instructions.

Close the door.

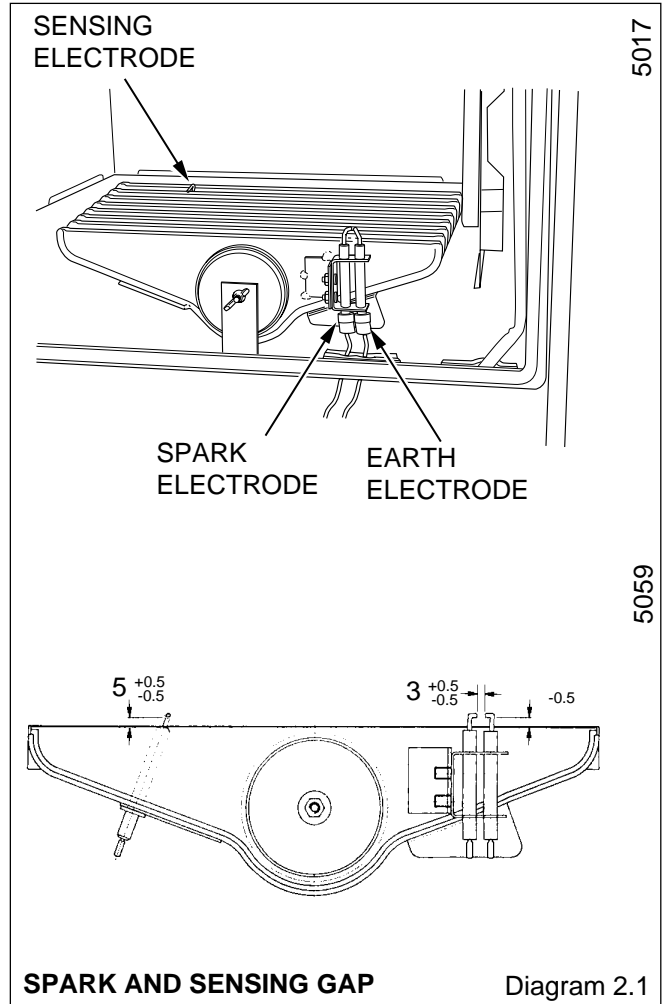

## 3 Fault Finding

### 3.1 Initial Checks

If the boiler fails to operate, first check the following:-

1) That the electrical supply is available at the boiler and the fuses are in order.

**NOTE: THE BOILER CONTROL BOARDS CAN BE DAMAGED BY INCORRECT TESTING WITH THE POWER ON.**

2) Make sure that the system pressure gauge registers 0.7bar, minimum, and that the automatic air vent works. Refer to Installation Instructions, Section 11.2.

3) That the gas supply is available at the boiler and purged of air.

4) That the boiler is set for the required service.

5) With the boiler central heating selector switched "Off", see diagram 6.1 Installation Instructions, check that the domestic water supply is available and water flows freely from the hot taps. Close the taps.

6) With the boiler central heating selector switched "ON", see diagram 6.1 Installation Instructions, check that all heating system controls, if fitted, are working correctly and calling for heat. If not isolate the boiler from the electrical supply.

Disconnect the rear multipole connector at the base of the boiler and release the cable from the clamp. Remove the connector cover and dependent on the type of control fitted test for continuity, mains or at terminals 1 and 2, see diagram 3.1.

7) Check reset button see diagram 6.1 Installation Instructions, - if red neon is lit press button. In certain circumstances the red neon light may not come on, due to no system demand. Turn on a domestic hot water draw off tap to create a demand, the light should come on, if reset is required.

Allow the boiler and system to cool down waiting at least a minimum of four minutes before pressing the reset button.

If this is satisfactory proceed with the detailed fault finding as Section 3.3.

### 3.2 Clock/Timer

If the clock has failed it can be bypassed by disconnecting the plug at the wall frame.

Gain access to the control box refer to Section 4.12, disconnect the clock wiring harness from the 4 way terminal block. Fit a yellow link between the terminals Y1 and Y2.

This is a temporary measure and the clock should be repaired or replaced as soon as possible.

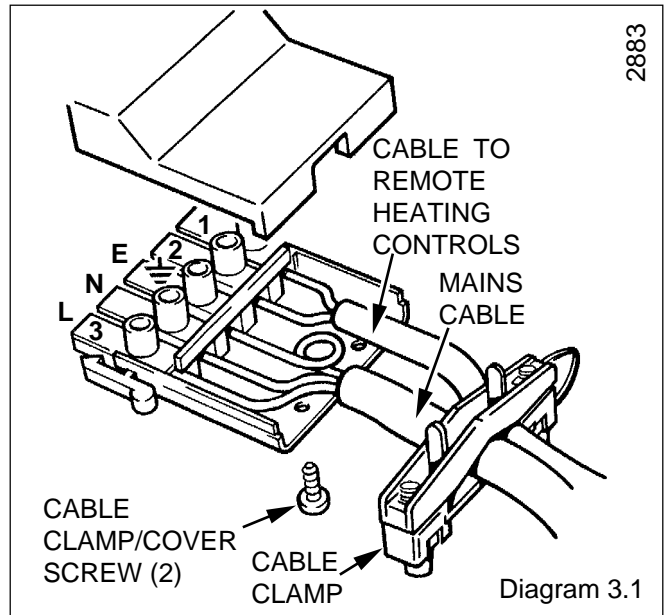

# 3 Fault Finding

## 3.3 Electrical

Preliminary electrical system checks, as outlined in a Multimeter Instruction book, are the first checks to be carried out during a fault finding procedure.

Isolate the boiler from the electrical supply, refer to Section 1.3.

Gain access to the boiler controls by removing the outer case, refer to Section 1.4. Check that all cables and connectors are secure.

Gain access to the control board, refer to Section 4.12. Check all cables at the multipin connectors on the board.

Test the two fuses on the main control board and renew as necessary. Fuse 1 type (2AT), Fuse 2 type T (630 mA). If a fuse fails repeatedly or the initial fault-finding checks described in Section 1.1 indicate a boiler fault, check the boiler electrical circuits and follow the fault finding procedures, see diagram 3.2, 3.3, 3.4 and for clock/timer fault finding, diagram 3.5 and 3.6.

On completion of a fault finding task that has required the disconnection and making of electrical connections then checks, for earth continuity, polarity and resistance to earth must be carried out.

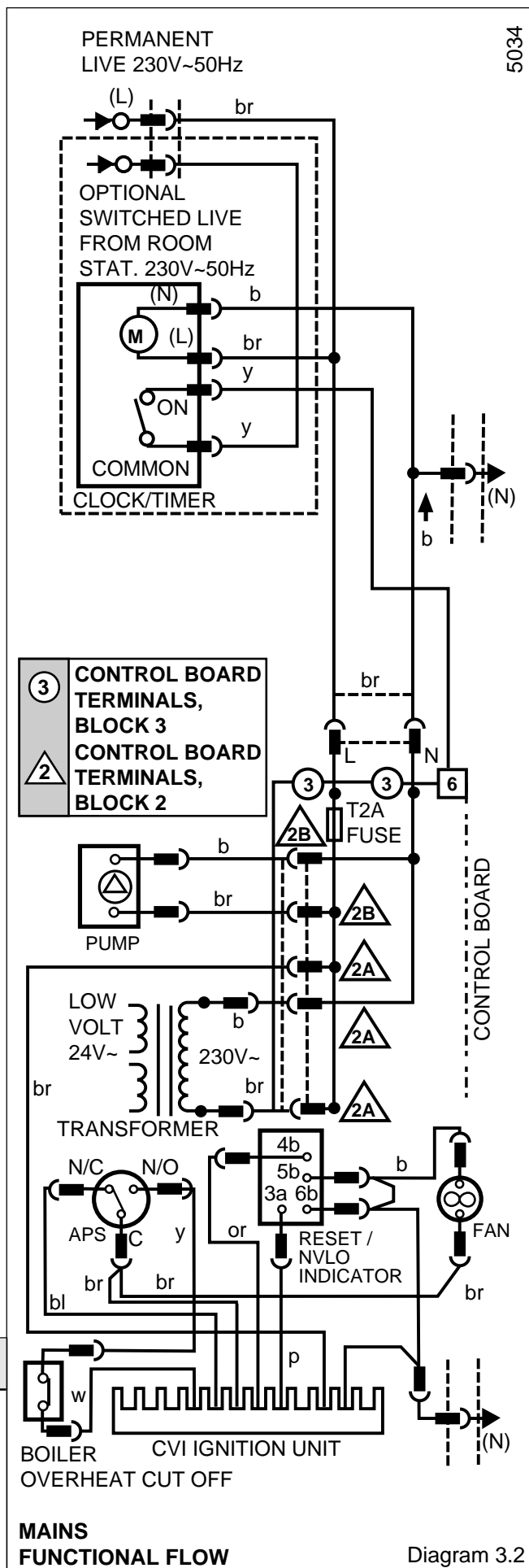

### 3 Fault Finding

5067

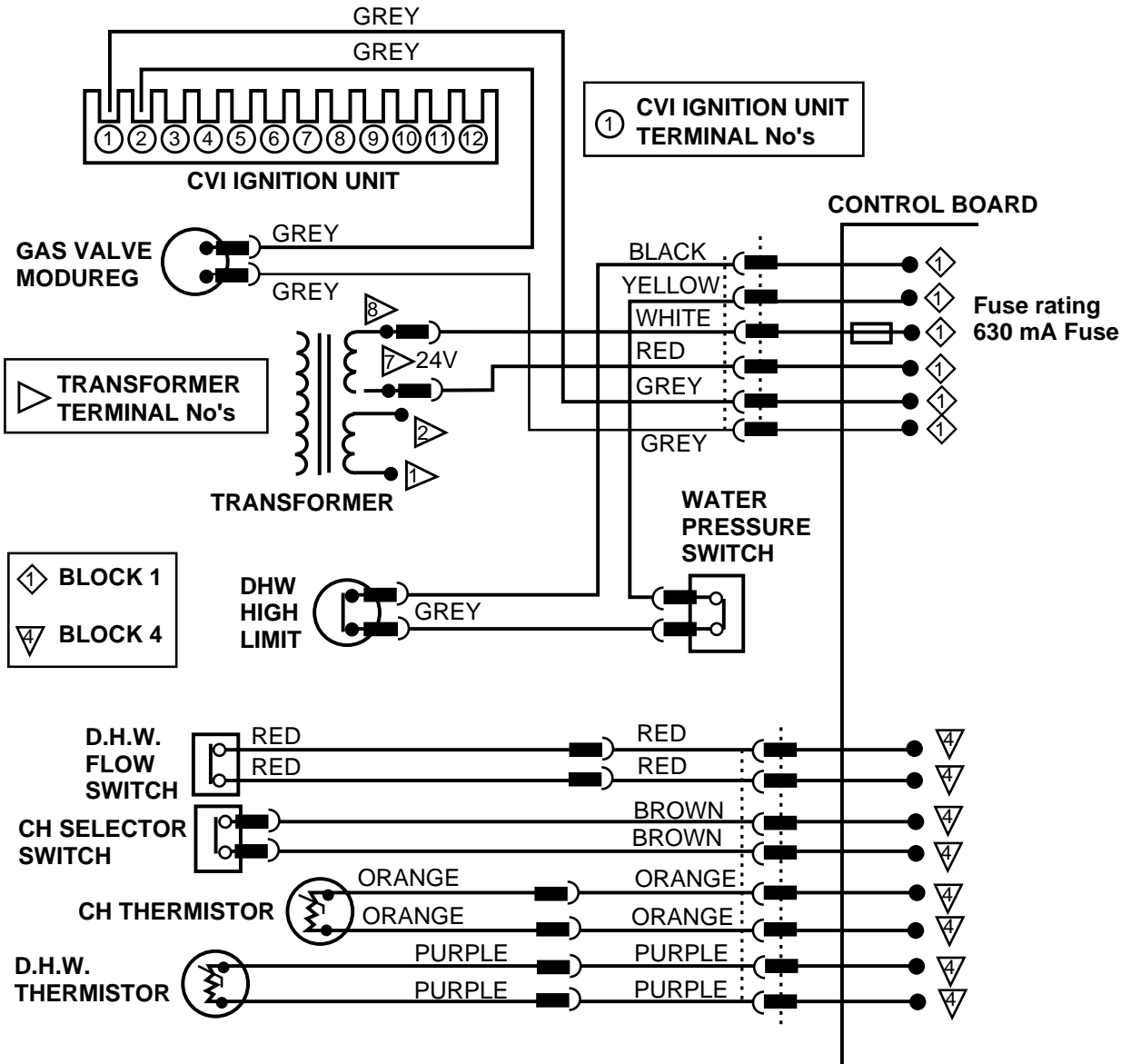

Diagram 3.3

### 3 Fault Finding

5063

Carry out the initial fault finding checks described in Section 3.1.  
 Check that gas, water and electricity are available at the boiler.  
 Before starting tests isolate the boiler, make sure that the remote controls are not calling for duty and there is no domestic hot water demand.

Remove the outer case, control housing and it's cover.  
 Check all connections on the control board and the boiler components, rectify or renew as necessary. Two dummy two way connectors are provided for ease of testing continuity. Remove fuses and test for continuity, if faulty, check cables and connections for shorting to E or N, rectify if necessary and replace fuse, with spare provided.  
 Check central heating water pressure, repressurize if necessary.  
 Make sure boiler is cold. Check all pipes and connections between the Air Pressure Switch (APS) fan and combustion sample point. Make sure sample point cap is fitted correctly. The boiler will go to lockout if the boiler overheat cut off goes open circuit, or the boiler fails to detect flame.

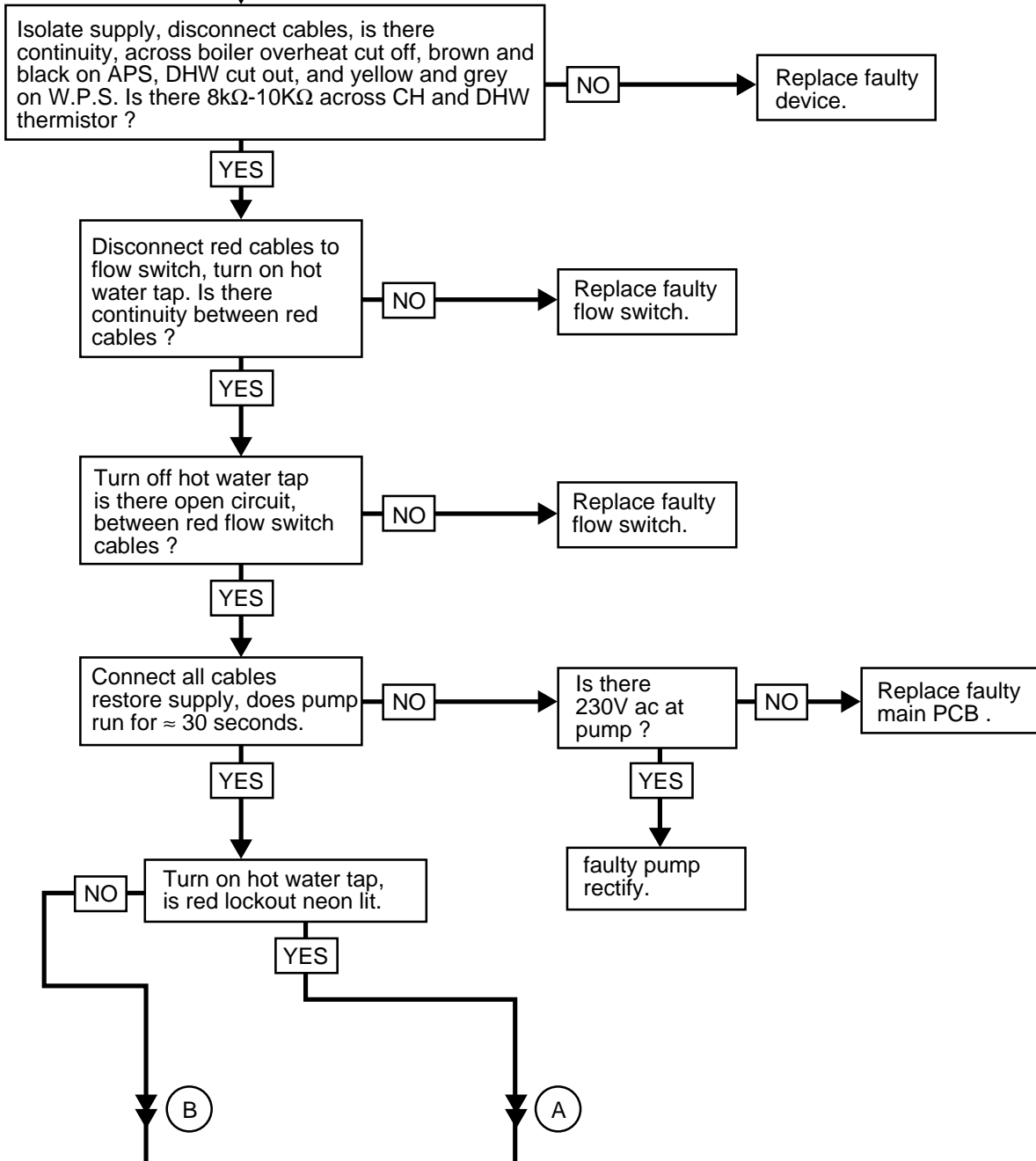

CONTINUED

Diagram 3.4

### 3 Fault Finding

5064

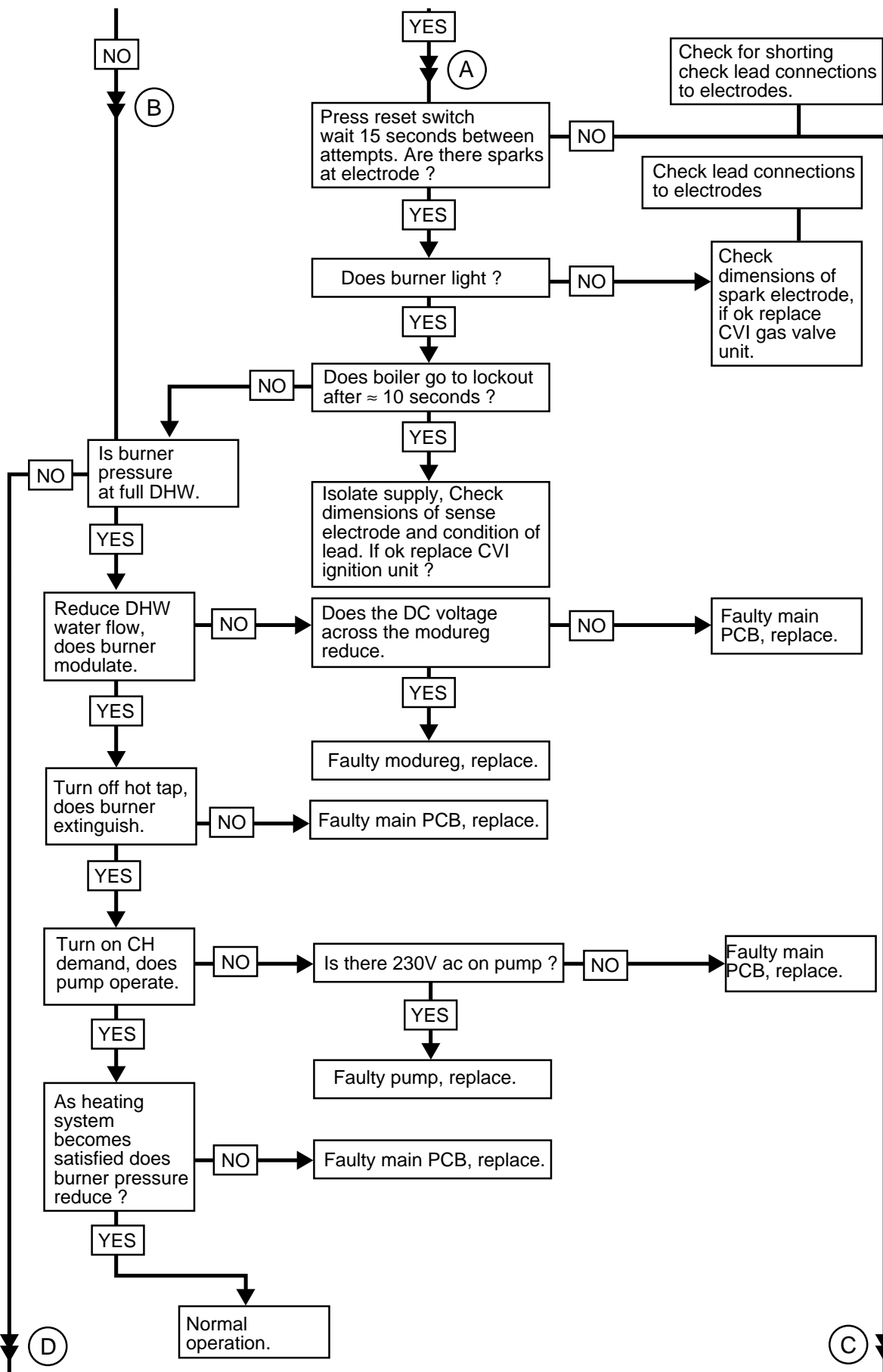

CONTINUED

Diagram 3.4

### 3 Fault Finding

5065

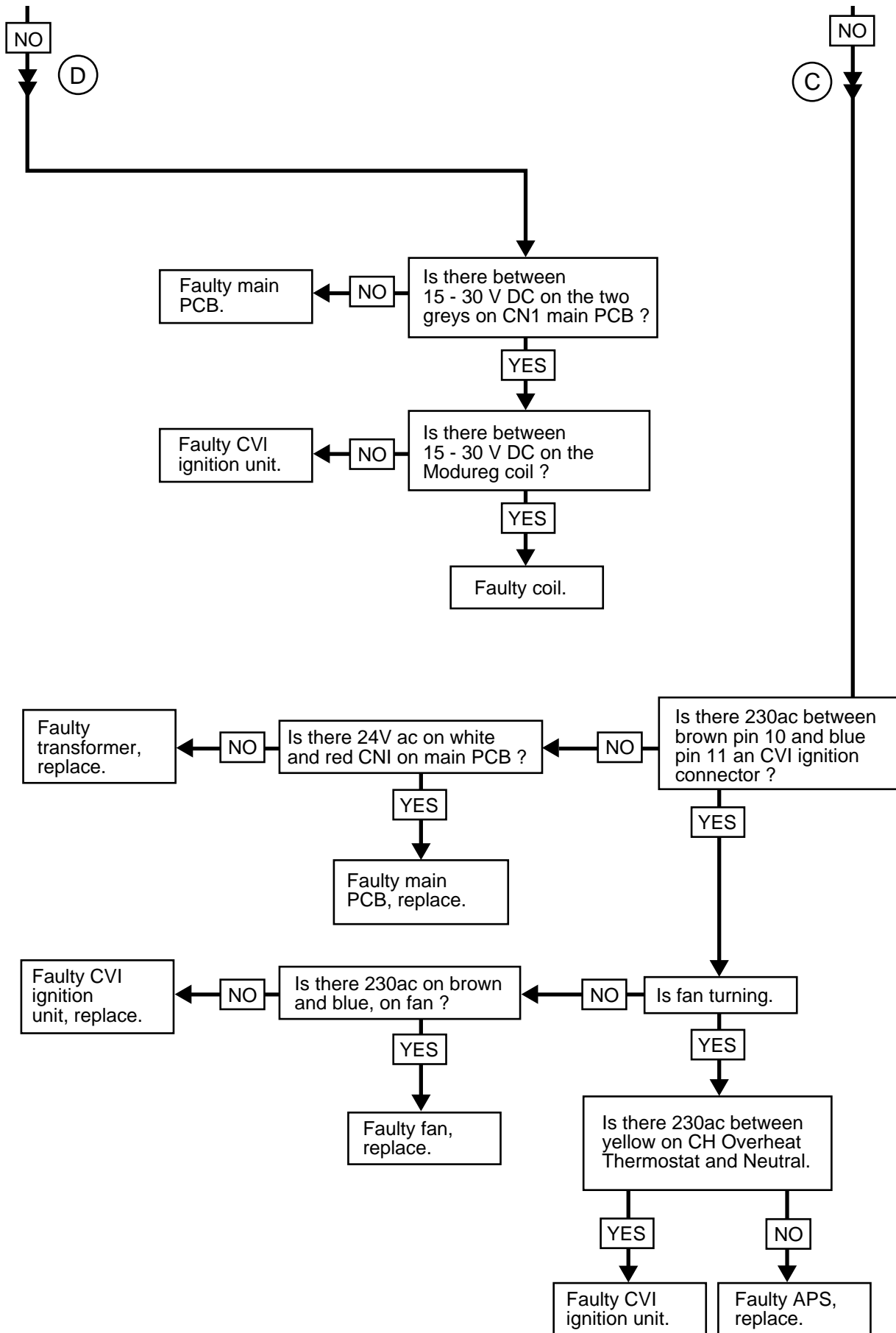

Diagram 3.4



### 3 Fault Finding

5665

If mains potential room thermostat is connected, make sure that the switch live is connected to Pin 1 in the 5 pole connector.  
Check continuity of clock/timer harness, ensure an electrical supply is available, make sure that remote controls are calling for heat.

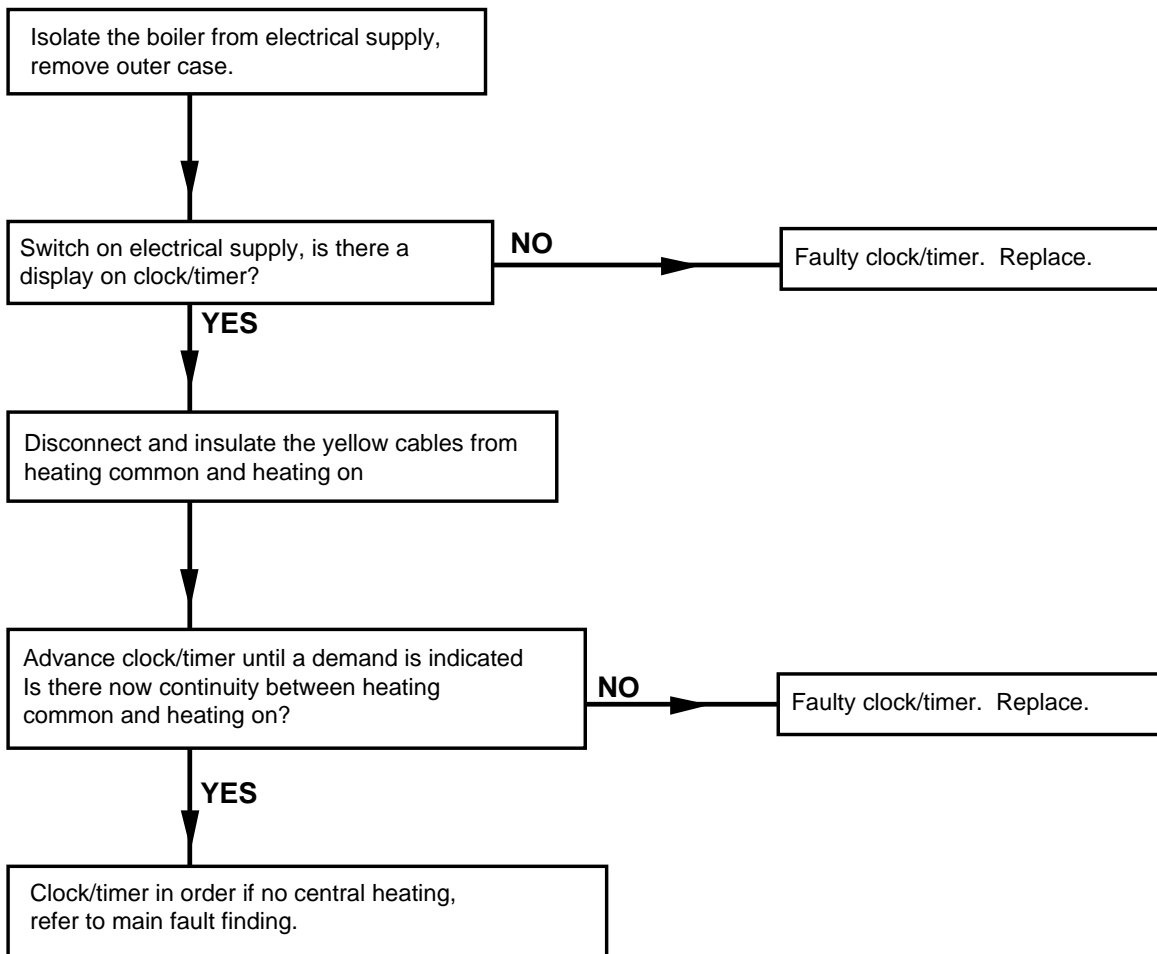

**DIGITAL CLOCK/TIMER FAULT FINDING**

Diagram 3.5

#### CLOCK FAULT FINDING

5666

If a mains potential room thermostat is connected, make sure that the switch line is connected to pin 1 in the 5 pole connector.

Check continuity of clock harness, make sure an electrical supply is available make sure that remote controls are calling for heat.

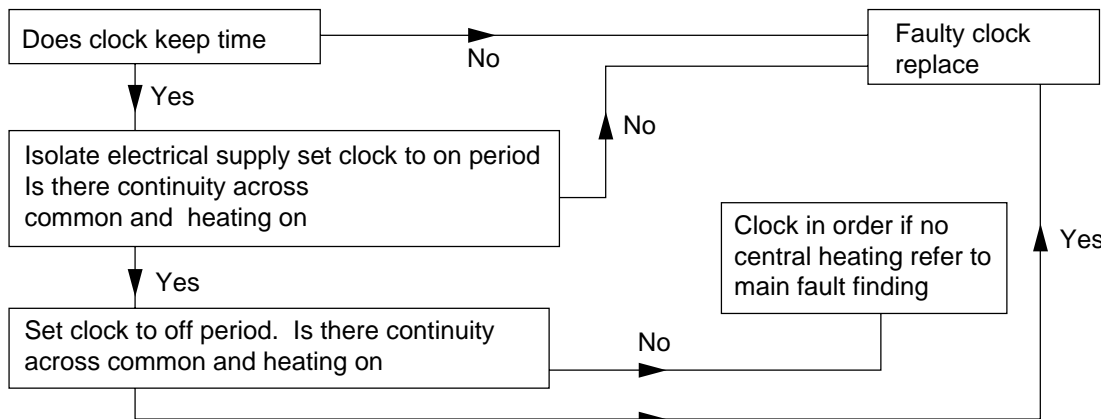

**ELECTRO/MECHANICAL CLOCK/TIMER FAULT FINDING**

Diagram 3.6

## 4 Replacement of Parts

Before replacing any part please read points below:-

Replacement of parts must only be carried out by a competent person.

1. Refer to Section 1.1.
2. Always isolate the boiler from the electrical and as required, the gas supply, as Section 1.3.
3. On completion, make good any water loss and pressurise the system to initial design pressure, refer to "Commissioning" in the Installation Instructions.

Before starting refer to Section 1.1

Isolate the boiler from the electrical supply, refer to Section 1.4 and 1.5

### 4.1 Fan

Disconnect the two electrical connectors at the fan, see diagram 4.1. It is not necessary to disconnect the green and yellow earth cable.

Remove the two flexible tubes from the fan.

When replacing the tubes from the air pressure switch ensure the lower (red) tube from the fan connects to the lower connection of the switch.

Remove the fan, secured with two screws at the front, also located into the flue elbow and clip at the rear.

To renew the motor and impeller, remove the three screws securing it to the housing.

Transfer the earth cable to the replacement motor terminal marked, fitting the earth cable and shakeproof washer when securing the fan.

To fit the fan, locate it into the flue elbow and rear bracket, push fully upward into the flue elbow to ensure a good seal, then secure the fan with the two screws.

The polarity of the two electrical connectors is not important.

### 4.2 Main Burner

Remove the inner case as Section 1.5.

Slacken the two wing nuts securing the flue collector, see diagram 4.2.

Remove the combustion chamber front panel, secured with four screws, see diagram 4.2.

Remove the burner support bracket wing nut and securing screw, see diagram 4.2

Remove the spark electrode assembly from the burner secured by two screws see diagram 4.3 and carefully lay it down in the combustion chamber.

NOTE: the sensing lead will be connected to the burner. Disconnect the lead when the burner is being removed.

Remove the main burner from the main injector at the rear. Raise the burner up and forwards. Take care not to damage the combustion chamber insulation.

Remove the sensing electrode and fit to new burner.

Make sure the sensing lead is reconnected and the main burner is fitted correctly on assembly, located on the main injector and horizontal, the tips of the rearmost blade under the two burner guides, see diagram 4.3.

Locate the combustion chamber front panel under the front edge of the flue hood on assembly, then secure all screws and wing nuts.

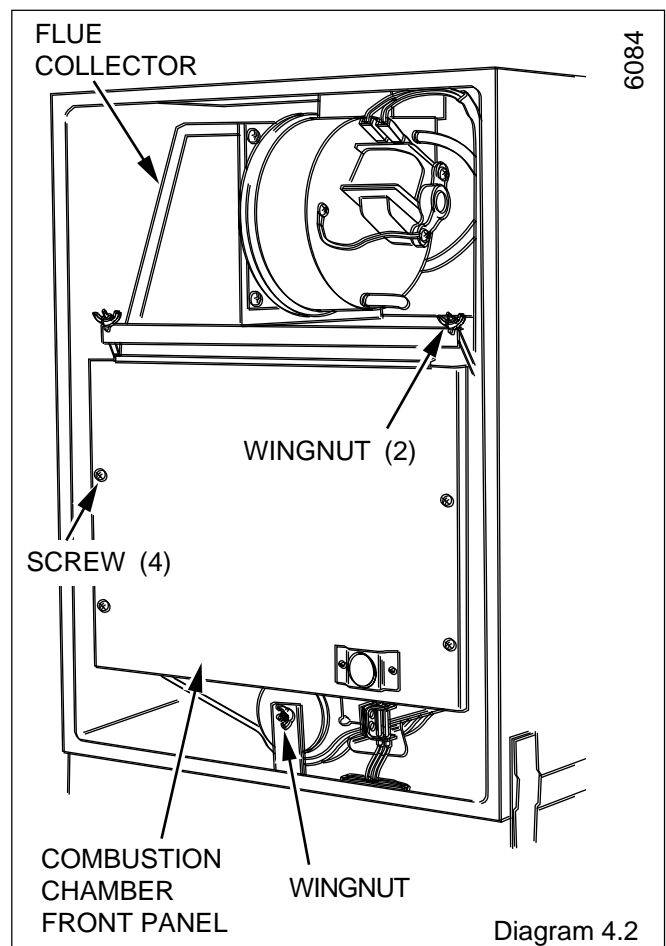
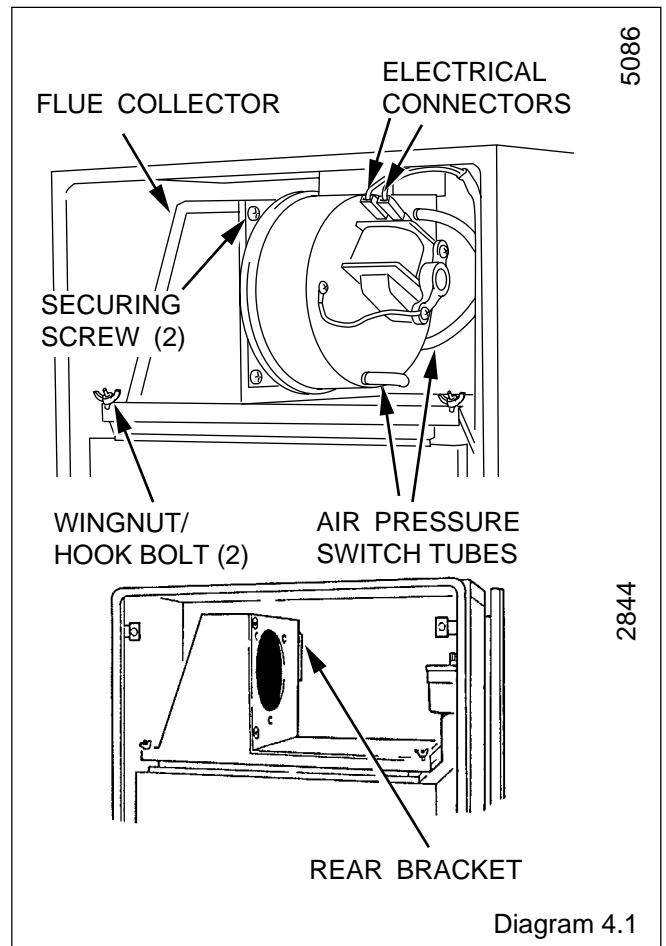

## 4 Replacement of Parts

### 4.3 Main Injector

Remove the main burner, refer to Section 4.2.

Unscrew the main injector.

When fitting the main injector, fit the new sealing washer, supplied, to ensure gas soundness.

### 4.4 Spark Electrode

Remove the inner case as Section 1.5.

Slacken the two wing nuts securing the flue collector, see diagram 4.2.

Remove the combustion chamber front panel, secured with four screws.

Remove the spark and earth electrode assembly leads and silicone tubes, securing nuts and washers

Disconnect the leads and silicone tubes.

NOTE: the ignition lead is black and the earth lead is white

### 4.5 Sensing Electrode

Remove the main burner refer to Section 4.2

### 4.6 Ignition Lead

Remove inner case as section 1.5, disconnect electrode assembly and lead as described in section 4.4.

Remove silicone tube and disconnect black lead at the ignition unit on gas valve. Slacken sealing angle and withdraw lead.

### 4.7 Sensing Lead

Remove main burner as described in Section 4.2 disconnect the lead from sensing electrode, disconnect lead at the ignition unit on gas valve.

Slacken sealing angle and withdraw lead.

### 4.8 Boiler Overheat Cutoff

Remove user control switch bracket by slackening securing screws, disconnect electrical connections, see diagram 4.6.

Disconnect the boiler overheat cutoff electrical connectors, see diagram 4.5.

Remove the overheat cutoff, secured with two screws, see diagram 4.5.

Use the heat sink compound supplied, between the mounting plate and the cutoff, when fitting it.

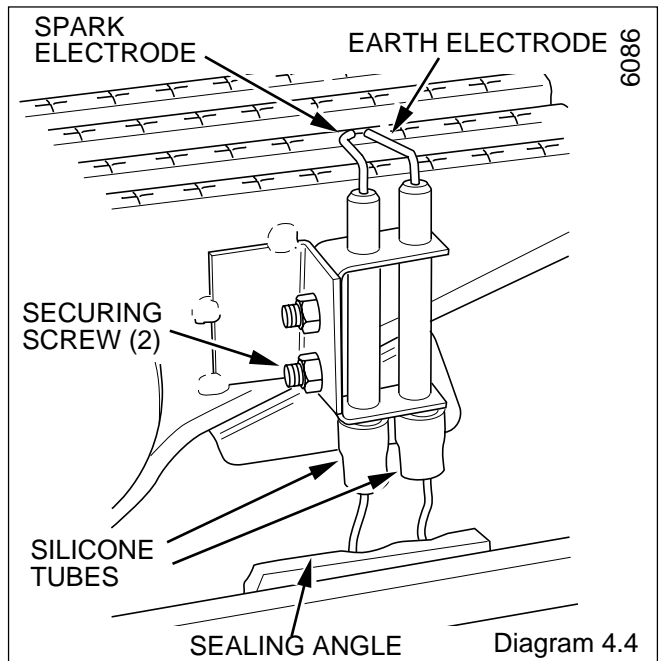

Diagram 4.4

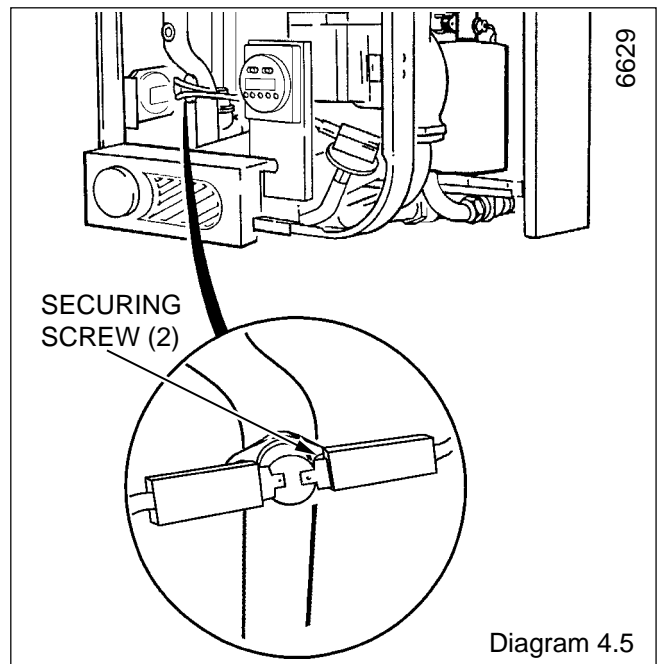

Diagram 4.5

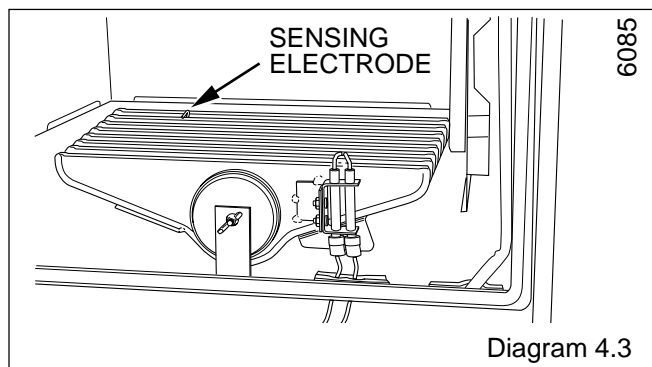

Diagram 4.3

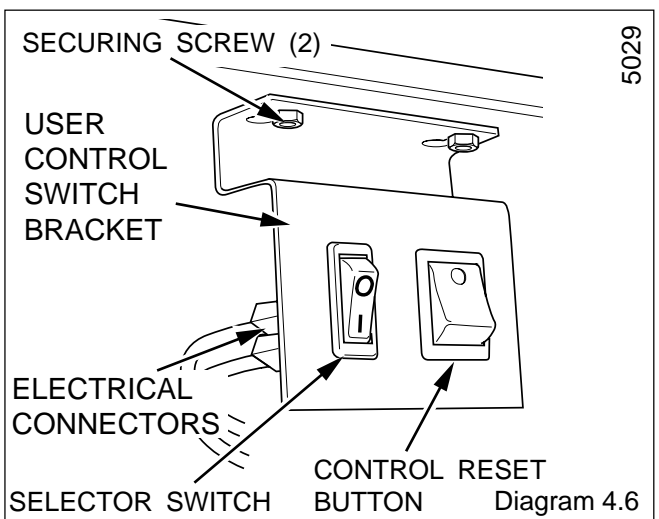

Diagram 4.6

## 4 Replacement of Parts

### 4.9 Water Pressure Switch

Release the water pressure and drain the central heating circuit of the boiler, refer to Section 1.3 and 1.6.

Remove the control housing, secured with two screws. Support control housing on a surface or by screwing it to front edge of the base, using the outer case securing screw, see diagram 4.10.

Disconnect the electrical connectors at the pressure microswitch, see diagram 4.7.

Remove pressure switch, see diagram 4.7.

Replace the "O" ring seal with the new seal provided.

Make sure that the switch terminals are facing diagonally forwards to give access, as shown in diagram 4.7.

Reconnect the electrical connections, refer to diagram 4.12.

### 4.10 Domestic Hot Water High Limit Control

Remove the pump, see Section 4.25.

Disconnect the electrical connectors at the domestic hot water high limit control, see diagram 4.8.

Remove the high limit control from the flow pipe, secured with two screws.

Use the heat sink compound supplied, between the mounting plate and the control.

When refitting the electrical connections to the high limit control the polarity is not important, see diagram 4.12.

### 4.11 Pressure Gauge

Remove the control housing assembly, see Section 4.9

Release the water pressure and drain the central heating circuit of the boiler, refer to Section 1.3 and 1.6.

Remove the pressure gauge bracket.

Disconnect the pressure gauge connection from the safety valve, discard the washer, see diagram 4.9.

Remove the pressure gauge secured with the retaining spring tabs.

Locate the supplied washer under the pressure gauge connection when refitted to the safety valve.

### 4.12 Control Boards

Remove the clock/timer mounting bracket securing screws, see diagram 4.29.

Remove control housing cover and fascia, see diagram 4.10.

Remove the control housing assembly, Section 4.9.

Disconnect all multi-pin connectors, see diagram 4.11.

Remove the control boards from the support posts, noting their correct positions. Great care must be taken when handling any control board.

**THE MAIN CONTROL BOARD MUST BE KEPT IN THE ANTI STATIC HOLDER UNTIL IMMEDIATE REQUIREMENT.**

To connect the multi-pin connectors correctly, see diagram 4.15.

When replacing the main control board check and if necessary adjust the main burner gas pressure in both the hot water and central heating modes. Refer to "Commissioning" in the Installation Instructions.

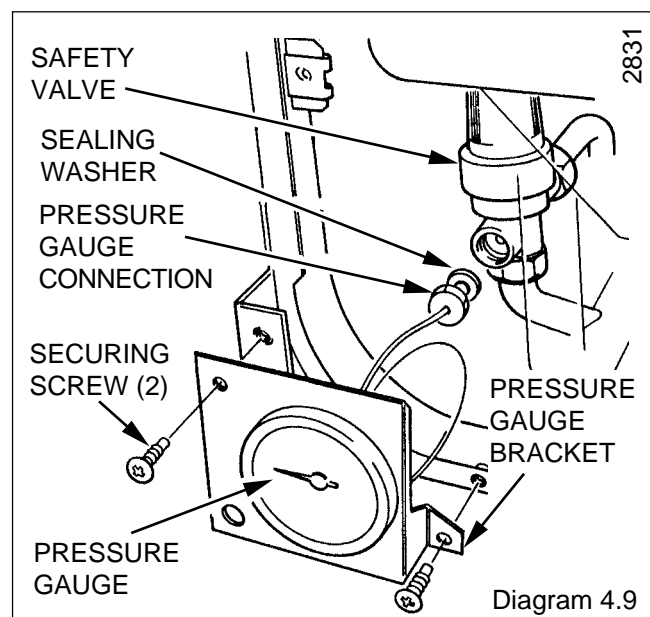
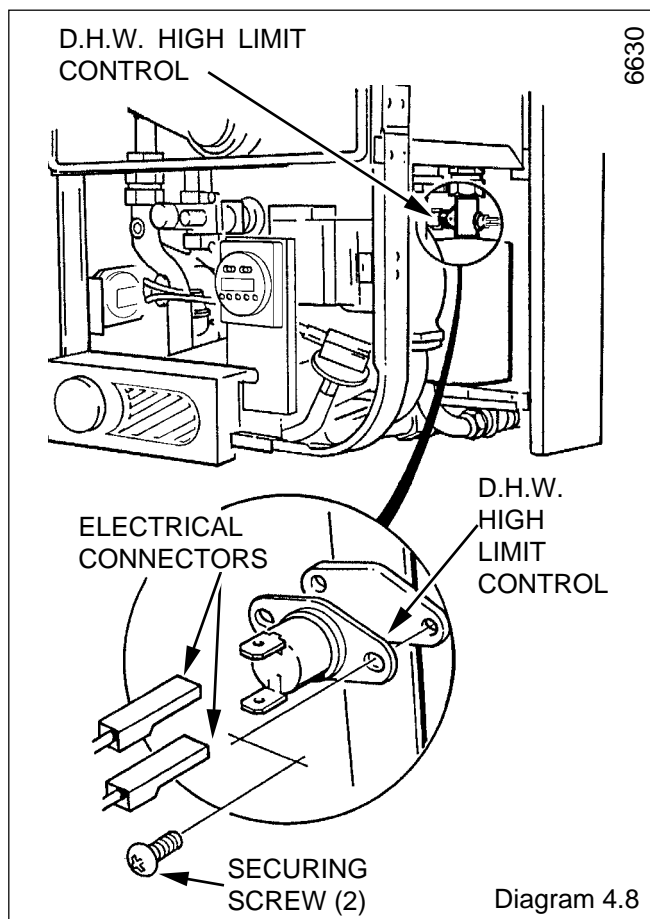
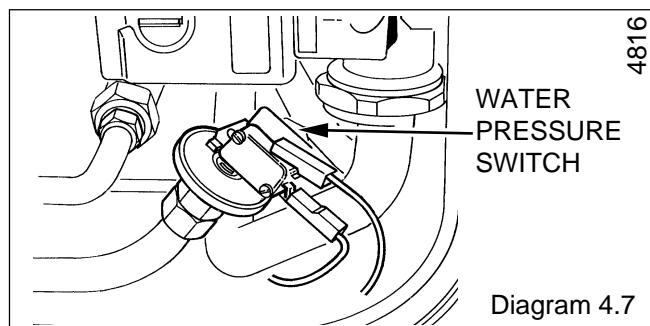

## 4 Replacement of Parts

### 4.13 Transformer

Before starting, refer to Section 1.1

Isolate the boiler from the electrical supply, refer to section 1.3

Remove the outer case, refer to section 1.4

Remove the control housing, refer to section 4.9. Support the control housing, see diagram 4.10.

Disconnect the electrical connectors from the transformer, see diagram 4.11.

Remove the transformer, noting the correct position.

Reconnect the cables, refer to diagram 4.15.

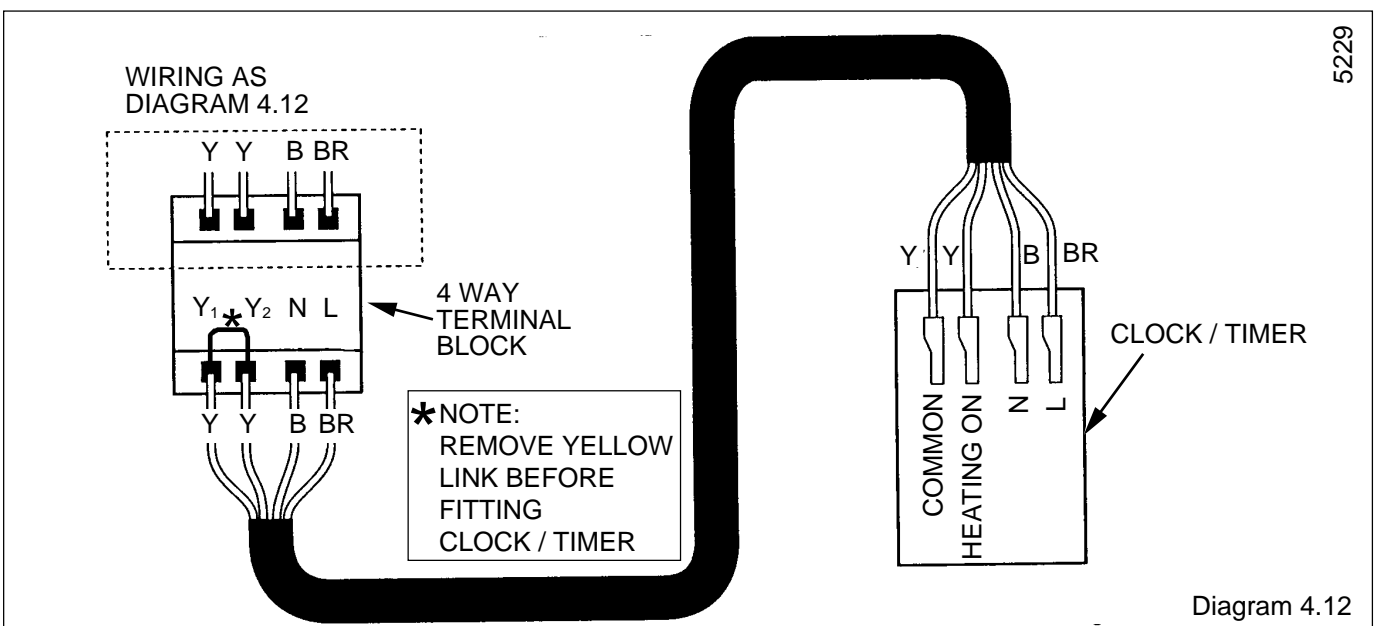
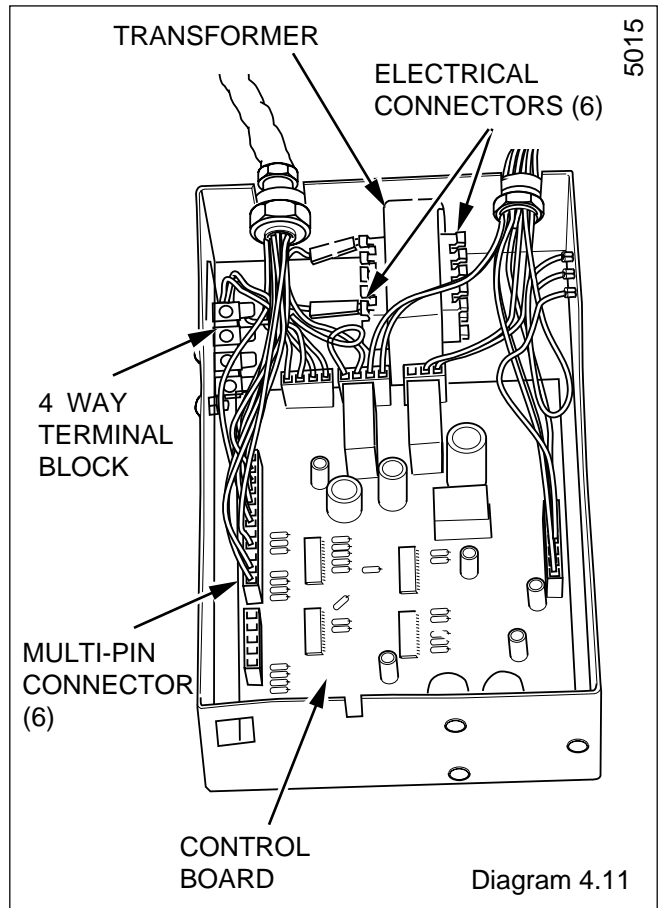
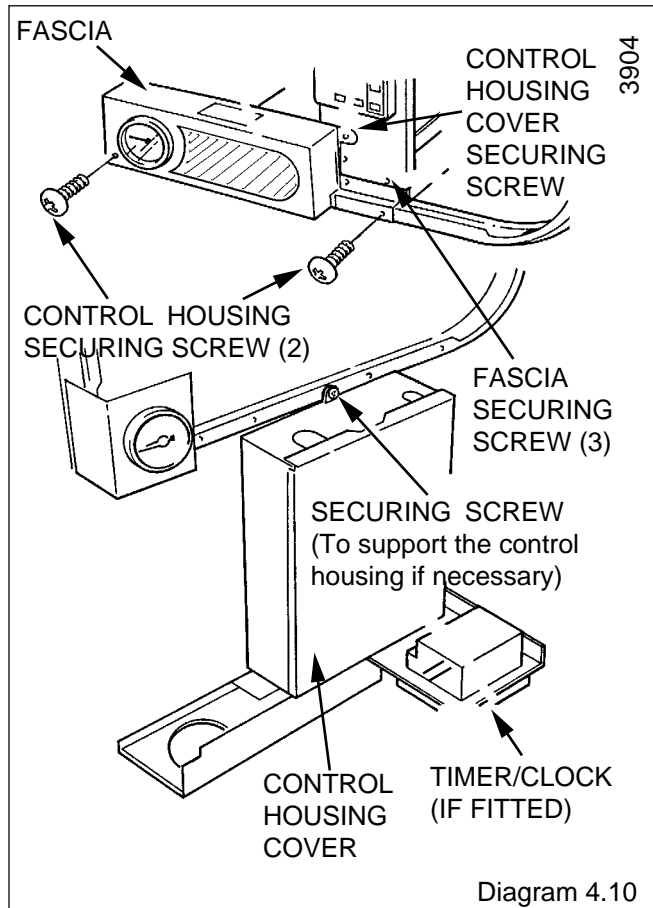

## 4 Replacement of Parts

### 4.14 Gas Valve

If applicable remove the clock/timer mounting bracket, see diagram 4.29

Remove control box housing, see Section 4.9.

Remove the user control switch bracket, see diagram 4.6.

Disconnect the ignition unit and 2 electrical connectors. see diagram 4.13.

Remove the four extended hexagon screws at the right hand side of the gas valve,

Support the gas valve, disconnect the union nut at the gas service cock and remove the valve complete with the inlet pipe.

Separate the valve from the pipe, noting the fitted position.

Discard the "O" rings and fit the new ones supplied.

Fit modulator cables the polarity is not important.

Check and adjust the main burner gas pressure in the hot water and central heating modes, refer to "Commissioning" in the Installation Instructions.

### 4.15 Ignition Unit

Remove control box housing, see Section 4.11.

Remove the user control switch bracket, see diagram 4.6.

Remove the ignition unit securing screws. see diagram 4.14.

Disconnect the electrical connector and the three electrode leads.

Remove ignition unit.

Note: when re-fitting make sure the electrode leads are fitted to the correct terminals. see diagram 4.14.

### 4.16 Central Heating Selector Switch and Control Rest Button

Slacken the user control switch bracket securing screws and remove the bracket from the keyhole slots, see diagram 4.6.

Pull the leads from the switch, see diagram 4.16.

To remove the switch press in the tabs on each side of it.

THE POLARITY OF THE ELECTRICAL CONNECTORS IS IMPORTANT, SEE DIAGRAM 4.15.

### 4.17 Modulator

Isolate the boiler from the electrical supply and close the gas service cock, refer to Section 1.3.

Remove the outer case, refer to Section 1.4.

Disconnect the two electrical connectors at the modulator, see diagram 4.17.

Remove the modulator, secured with two screws.

Discard the gasket and fit the new one supplied, when fitting the modulator.

Light, check and adjust the boiler if necessary, refer to "Commissioning" in the Installation Instructions.

### 4.18 Domestic Hot Water Flow Switch

Before commencing refer to Section 1.1

Isolate the boiler from the electrical supply, refer to Section 1.3.

Remove the outer case, refer to Section 1.4.

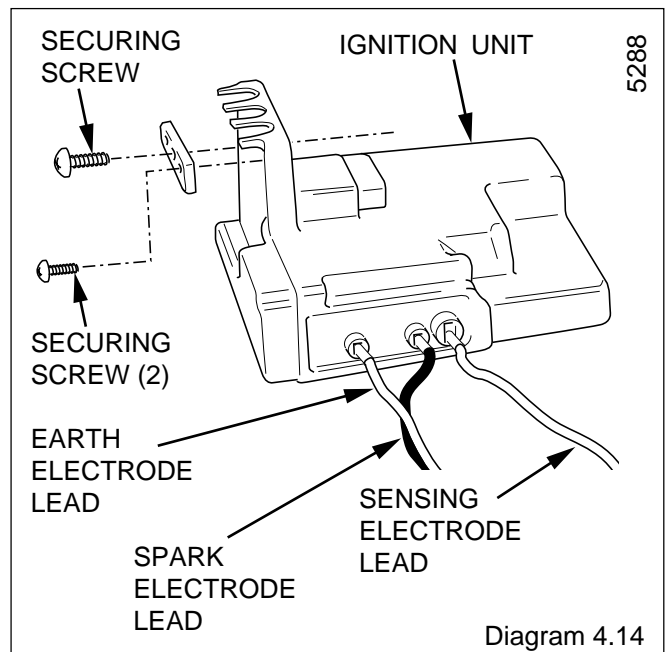
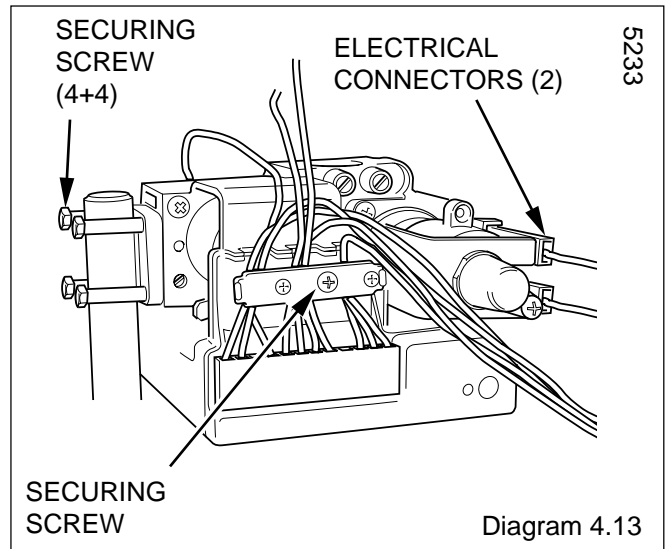

Isolate the domestic hot water inlet, release the domestic water pressure and drain, refer to Section 1.3 and 1.6.

Remove the control housing, refer to Section 4.9.

Remove the pressure gauge bracket, see diagram 4.9.

Disconnect the flow switch cables at the in line connectors.

Slacken or remove the clip securing the isolating valve, to ease removal.

To remove the flow switch disconnect the water inlet pipe assembly union nuts, see diagram 4.18, noting the fitted position.

Discard the sealing washers and use the new ones supplied.

It is recommended that the water inlet filter is cleaned or renewed at this stage.

Make sure that the switch is positioned correctly, with the flow arrow pointing upwards.

# 4 Replacement of Parts

5062

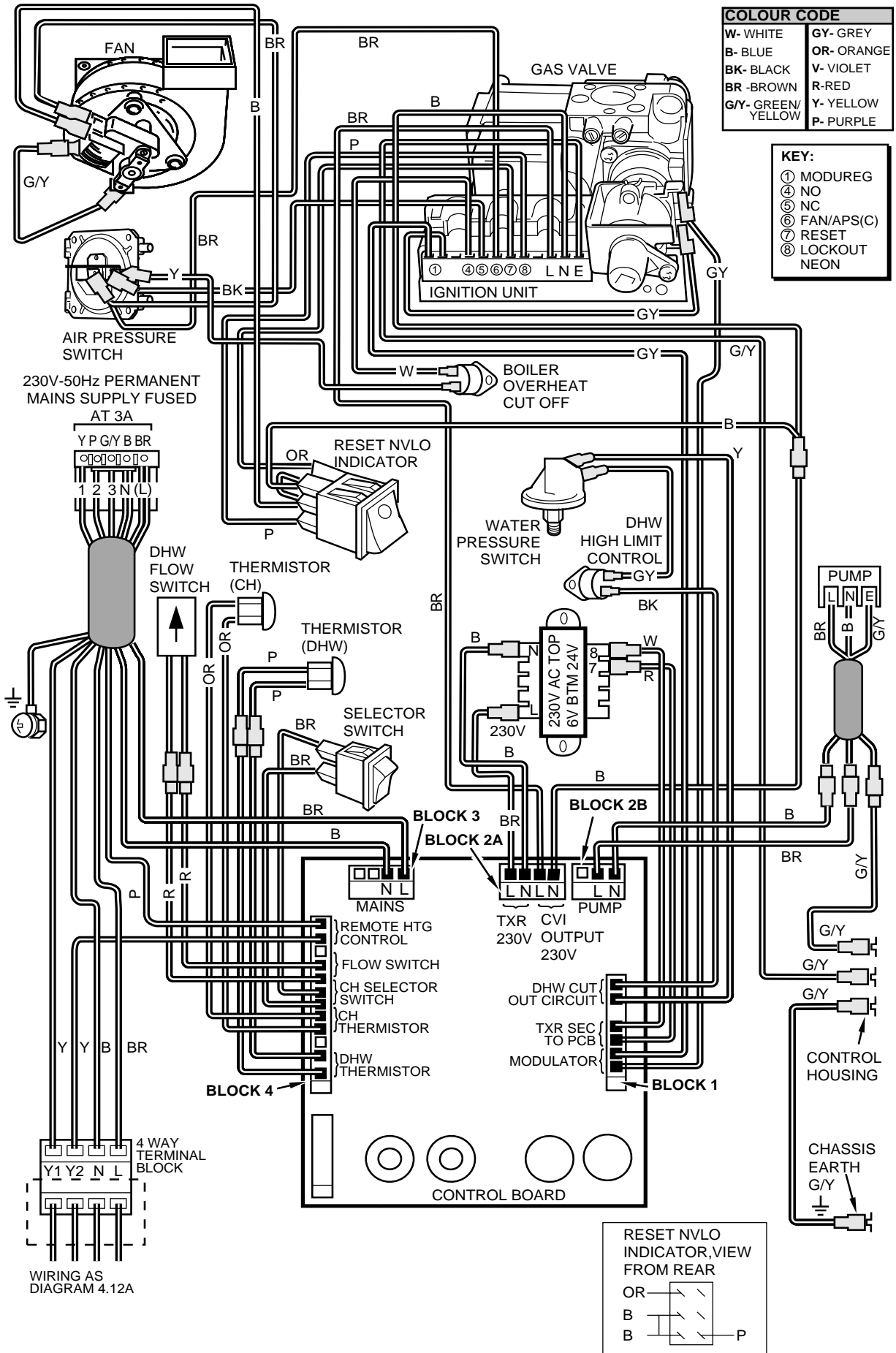

Diagram 4.15

## 4 Replacement of Parts

### 4.19 Thermistor - Heating

Release the water pressure and drain the heating circuit of the boiler, refer to Sections 1.3 and 1.6.

Disconnect the cables from the thermistor, see diagram 4.19.

Remove the thermistor, complete with its "O" ring.

The polarity of the electrical connections is not important.

### 4.20 Thermistor - Domestic Hot Water

On minimum clearance installations, remove the pump, see Section 4.25.

Release the water pressure and drain the domestic circuit of the boiler, refer to Section 1.3 and 1.6.

Disconnect the cables from the thermistor, see diagram 4.19.

Remove the thermistor complete with its "O" ring.

The polarity of the electrical connections is not important.

### 4.21 Safety Valve

Release the water pressure and drain the central heating circuit of the boiler, refer to Section 1.3 and 1.6.

Remove the pressure gauge, refer to Section 4.11.

Disconnect the union nuts to release the safety valve, see diagram 4.20.

### 4.22 Water Inlet Filter

Release the water pressure and drain the domestic circuit of the boiler, refer to Section 1.3, 1.6 and 4.19 or 4.18 diagram.

### 4.23 Domestic Hot Water Throttle

Release the water pressure and drain the domestic circuit of the boiler, refer to Section 1.3 and 1.6.

Remove the domestic hot water inlet pipe assembly, refer to Section 4.18.

Remove the cap nut and carefully remove the throttle adjuster, by unscrewing and pushing it out, see diagram 4.21.

Clean if necessary, taking care not to damage the throttle body.

Reset the domestic hot water flow rate refer to Section 11.7 in Installation Instructions.

### 4.24 Mini Expansion Vessel

Release the water pressure and drain the domestic circuit of the boiler, refer to Section 1.3 and 1.6.

Remove the domestic hot water inlet pipe complete with the mini-expansion vessel from the boiler, refer to Section 4.18.

When refitting use the new sealing washer supplied.

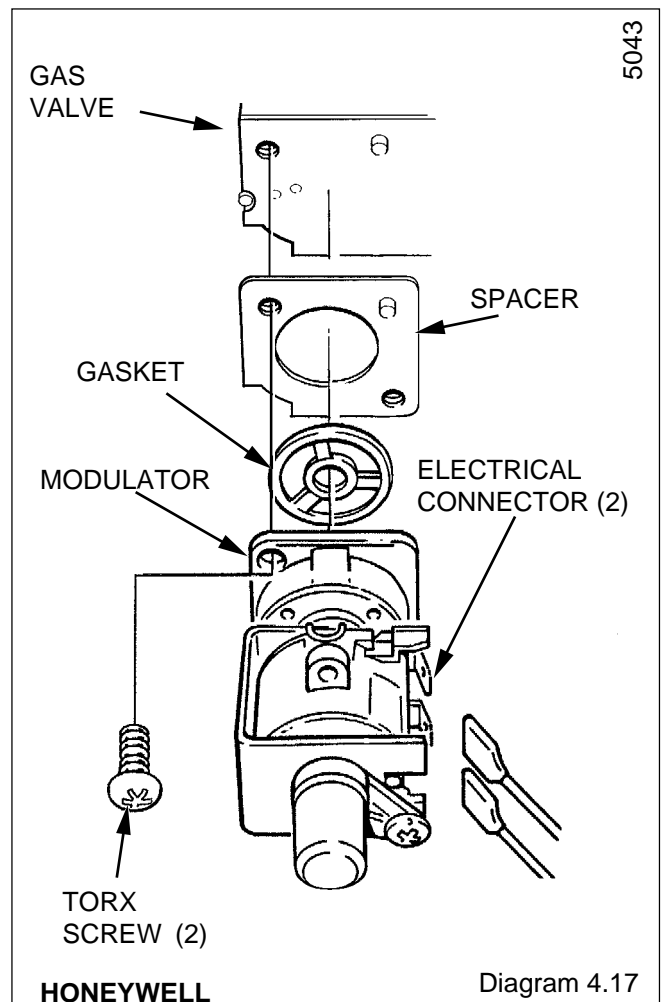
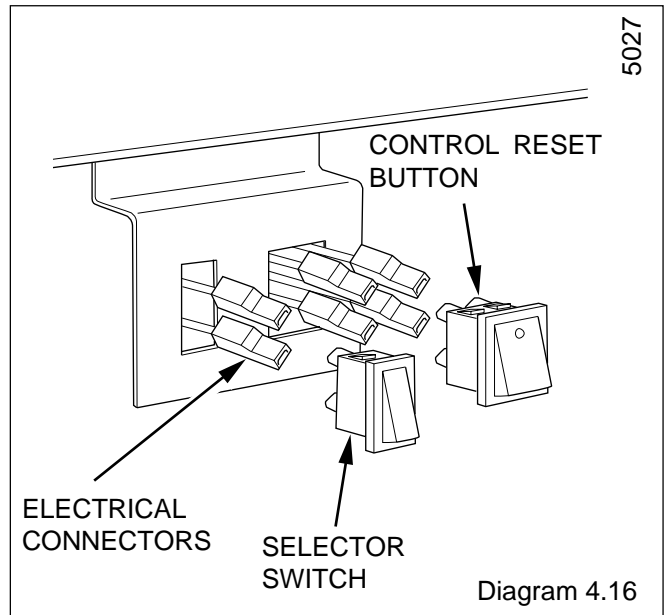



## 4 Replacement of Parts

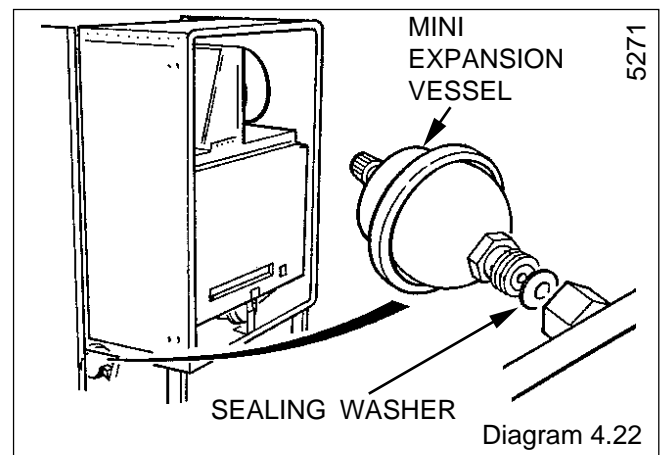
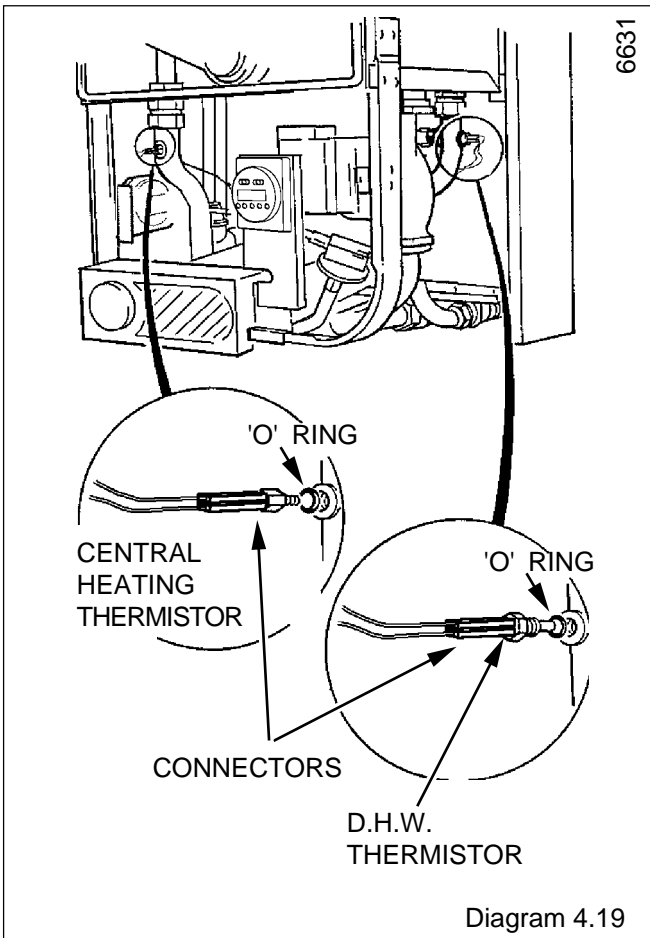
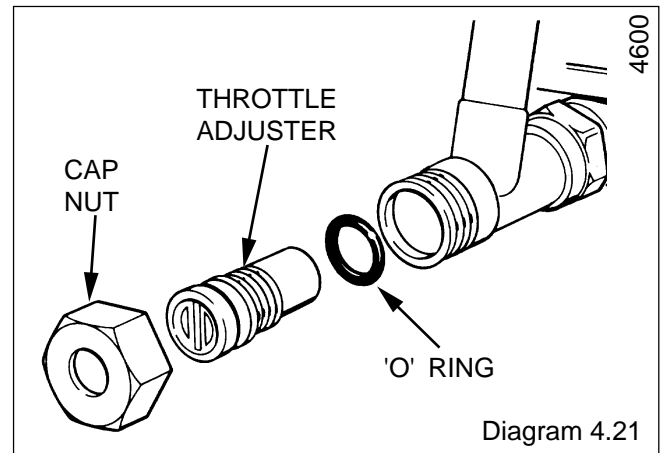
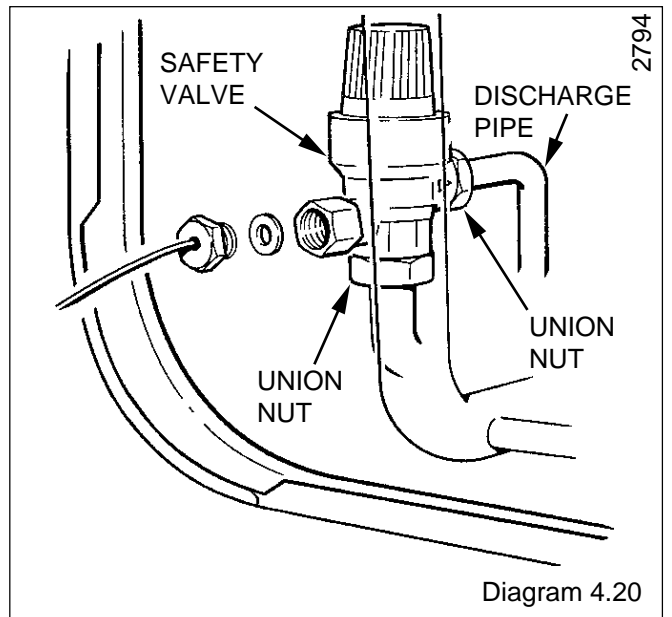
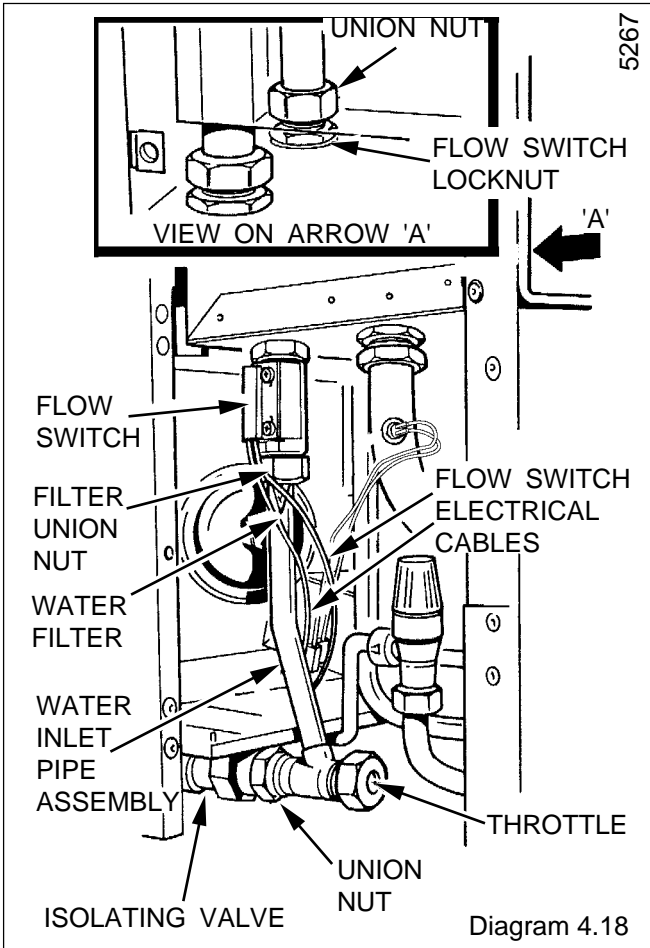

## 4 Replacement of Parts

### 4.25 Pump

Release the water pressure and drain the central heating circuit of the boiler, refer to Section 1.3 and 1.6.

Remove control housing, see Section 4.9.

Disconnect the electrical connectors at the water pressure microswitch. Remove the water pressure switch, refer to Section 4.9.

Remove the terminal cover from the pump and disconnect the cable, see diagram 4.23.

Disconnect the pump at the unions.

Discard the sealing washers.

Make sure that the flow direction arrow is pointing upward when fitting, and use the new sealing washers.

Refit water pressure switch, refer to Section 4.9.

The flow adjuster on the new pump should be set to that of the original, refer also to Section 4.6 in the Installation Instructions.

The flow rate should be controlled by means of a valve in the heating flow, refer to Section 11.10 in the Installation Instructions.

Note: Should the pump fail to operate, refer to diagram 4.23. If all is in order, but the pump still does not operate, remove the end screw, or cap, see diagram 4.23, then turn the pump spindle to release any temporary seizure.

DO NOT HIT THE SPINDLE.

### 4.26 Automatic Air Vent

Release the water pressure and drain the central heating circuit of the boiler, refer to Section 1.3 and 1.6.

Remove the automatic air vent, see diagram 4.24.

SLACKEN THE SMALL CAP ON THE AIR VENT. THIS MUST NOT BE RE-TIGHTENED.

When refitting use the new sealing washer provided.

### 4.27 Heat Exchanger

Release the water pressure and drain the central heating and domestic hot water circuits refer to Section 1.3 and 1.6.

Remove the fan from the flue collector, refer to Section 4.1.

Remove the flue collector, secured with two wing nuts and hook bolts, see diagram 4.1.

Remove the main burner, refer to Section 4.2.

Remove the automatic air vent, refer to

Section 4.29.

If renewing the heat exchanger, transfer the air vent, using the new sealing washers provided.

Disconnect the union nuts of the heat exchanger to remove it, see diagram 4.24.

Locate the raised location tabs on the combustion chamber sides into the slots on the heat exchanger, see diagram 4.24.

Make sure that the main burner is located on the main injector and is horizontal, the tips of the rearmost blade under the two burner guides, see diagram 4.3.

The combustion chamber front panel should be fitted loosely, then the flue collector also fitted loosely, ensuring that it is seated correctly on the heat exchanger and over the top edge of the front panel.

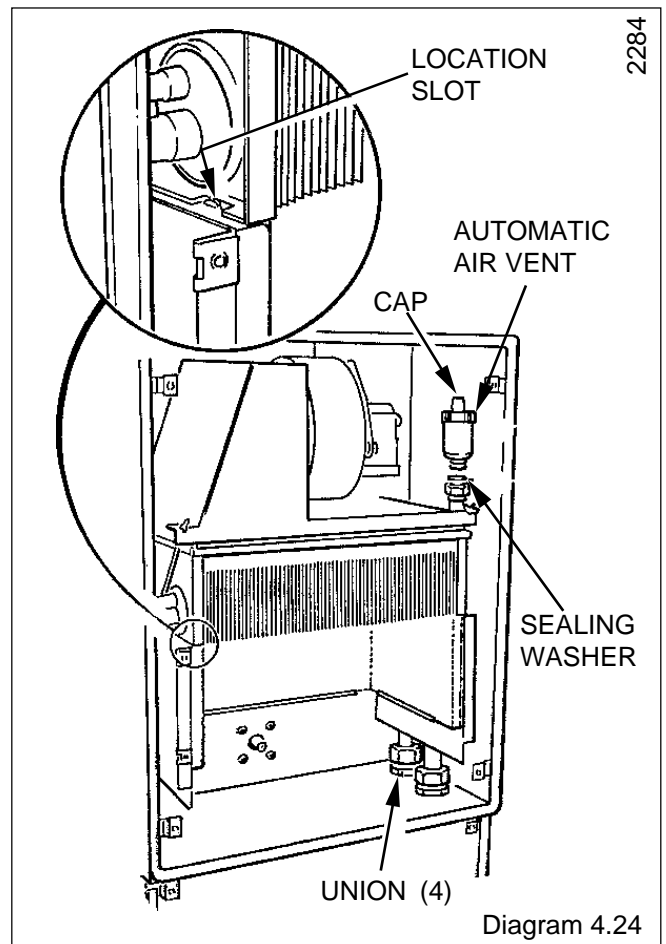
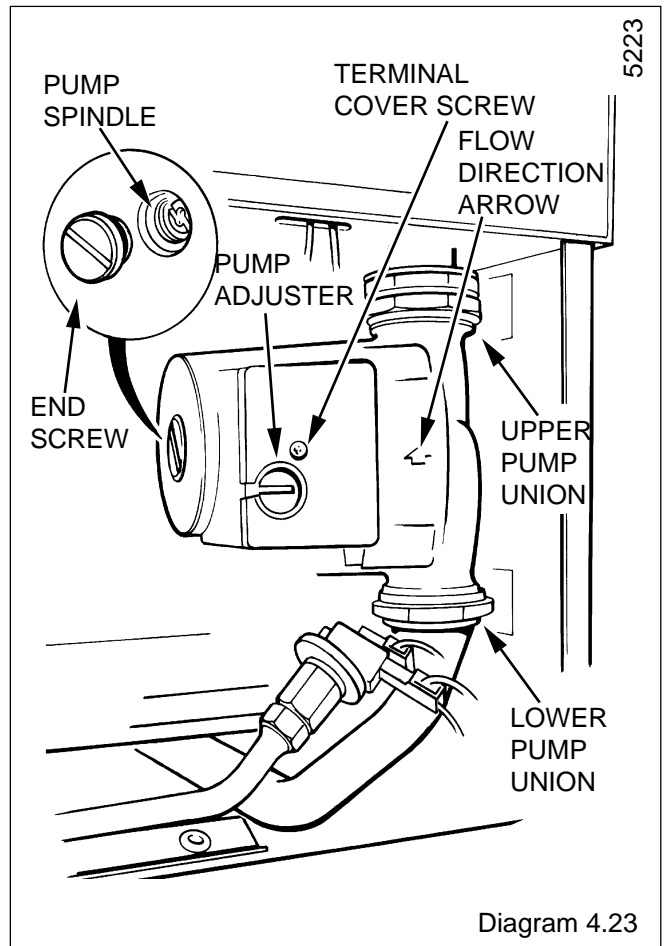

## 4 Replacement of Parts

### 4.28 Combustion Chamber Insulation

Remove the fan, refer to Section 4.1.

Remove the flue collector, secured with two wing nuts and hook bolts, see diagram 4.1.

Remove the combustion chamber front panel, secured with four screws, see diagram 4.2.

Remove the front insulation piece secured with a clip, see diagram 4.25.

Slide out both side insulation pieces

Pull the lower rear insulation forwards, then slide the upper rear insulation down from behind the heat exchanger.

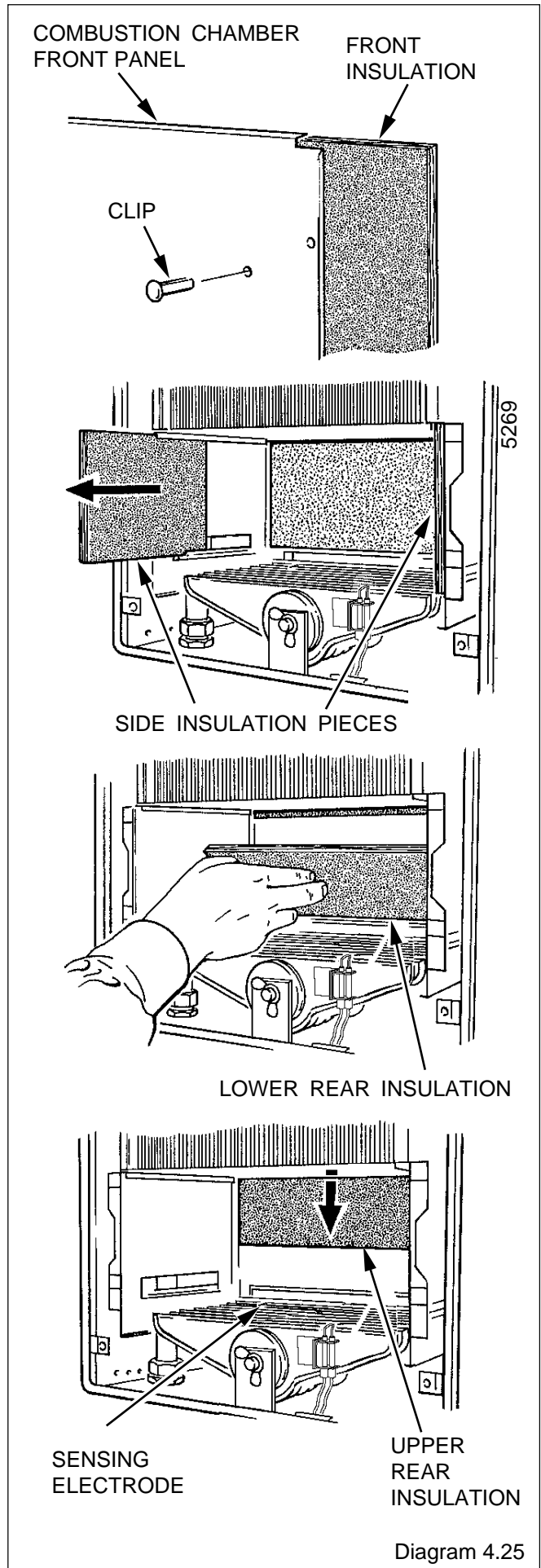

## 4 Replacement of Parts

### 4.29 Expansion Vessel

Renewal of the expansion vessel requires the boiler to be removed from the wall. As an alternative, a separate expansion vessel of the same specification may be connected as close as possible to the boiler, leaving the original in position, refer to the Installation Instructions.

Remove the outer case and the cover of the inner case, refer to Section 1.4 and 1.5.

Release the water pressure and drain, refer to Section 1.3 and 1.6.

Remove the fan from the flue collector, refer to Section 4.1.

Remove the flue elbow, secured to the boiler with four screws and to the air duct with two screws, see diagram 4.26.

Disconnect the boiler water connection union nuts at the front of the isolating valves, see diagram 1.1.

Disconnect the gas service cock union.

Disconnect the safety valve discharge pipe from the boiler, see diagram 4.20.

Separate the two parts of the boiler multi-pole electrical connector.

Slacken the clips of the gas service cock and the water isolating valves.

Remove the boiler from the mounting frame, secured with two screws at the top, see diagram 4.26. Pull the boiler from the isolating valves. Unhook the boiler at the top and lift off.

Carefully lay the boiler down on its side for access to the expansion vessel.

Disconnect the union nut connection, see diagram 4.27 and discard the sealing washer for the new one supplied.

Remove the expansion vessel, secured with three clamping screws.

Connect the union nut, when fitting the expansion vessel, before clamping it.

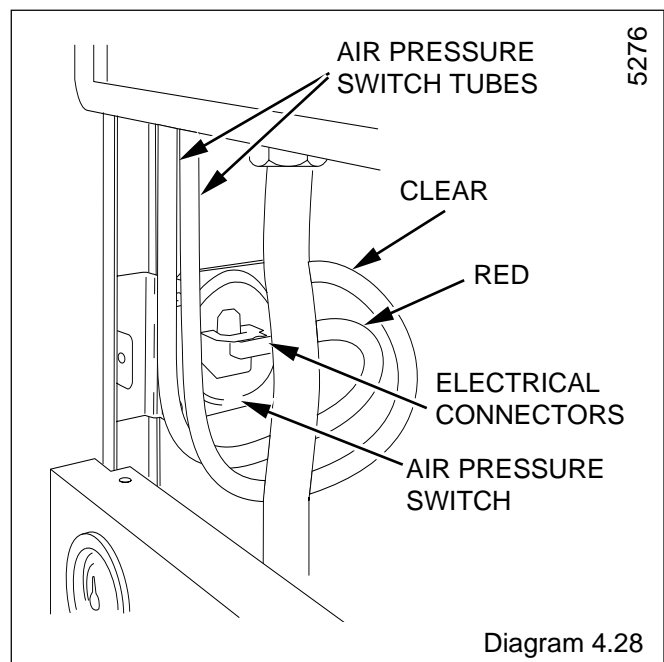
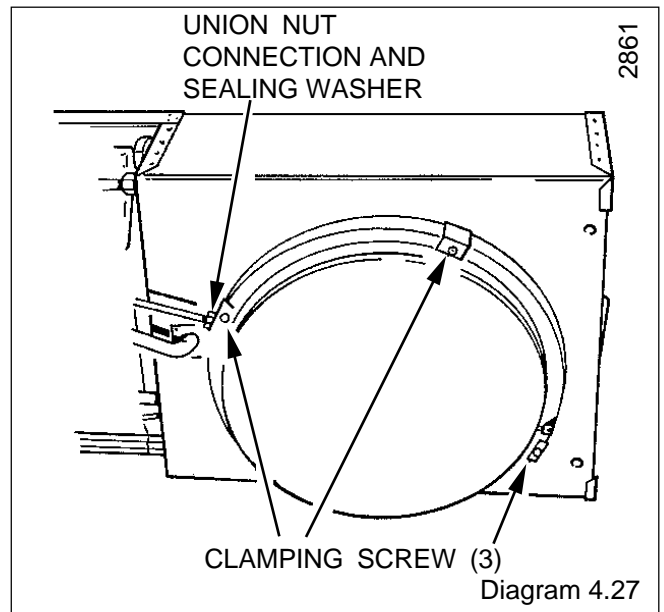
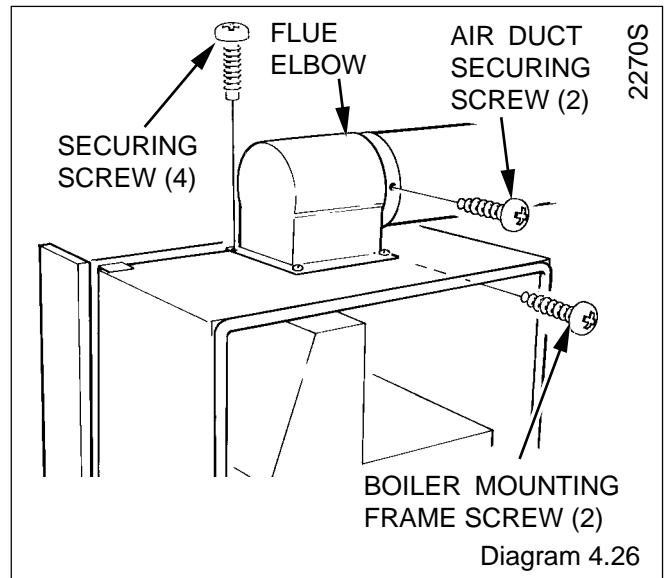

## 4 Replacement of Parts

### 4.30 Viewing Window

Remove the viewing window, secured with two screws. When fitting a new window use the gasket provided, see diagram 1.2.

### 4.31 Casing Seal

Remove the old seal, clean out the old adhesive.

Glue the new seal into place, making sure that there are no breaks in it.

### 4.32 Air Pressure Switch

Disconnect the two electrical connectors at the air pressure switch, see diagram 4.28.

Remove the flexible tubes from the switch.

Remove the air pressure switch, secured with two screws.

When replacing the tubes to the air pressure switch make sure that the lower (red) tube from the fan connects to the lower connection of the switch.

The polarity of the electrical connections is important, refer to diagram 4.15.

### 4.33 Clock/Timer - if fitted

ELECTRO/MECHANICAL and DIGITAL clock/timer - Release the mounting bracket securing screws, see diagram 4.29

Disconnect electrical cables, release securing clip to remove the clock/timer spacer, see diagram 4.30.

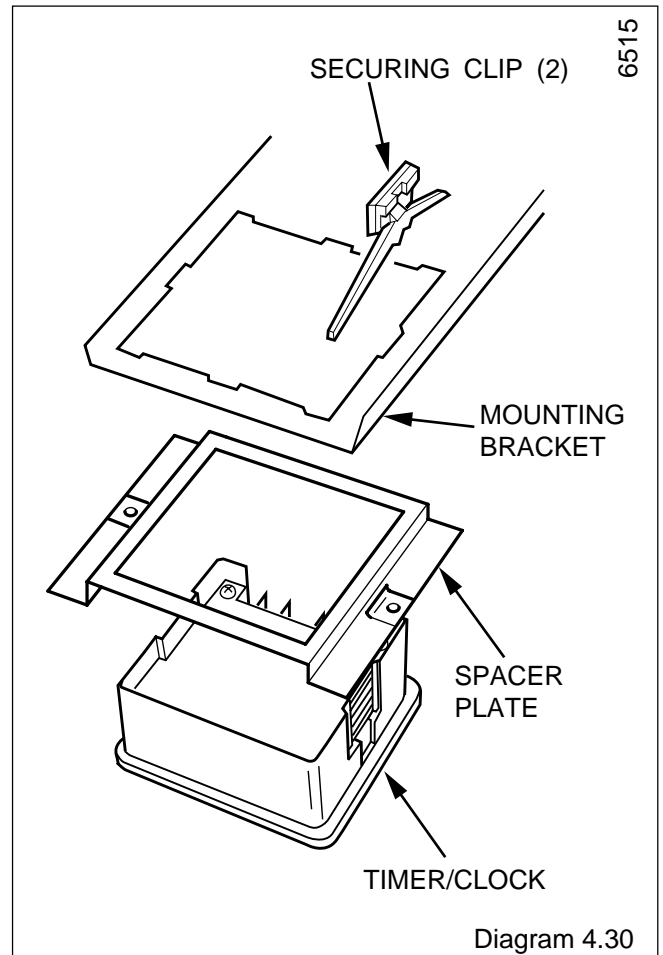
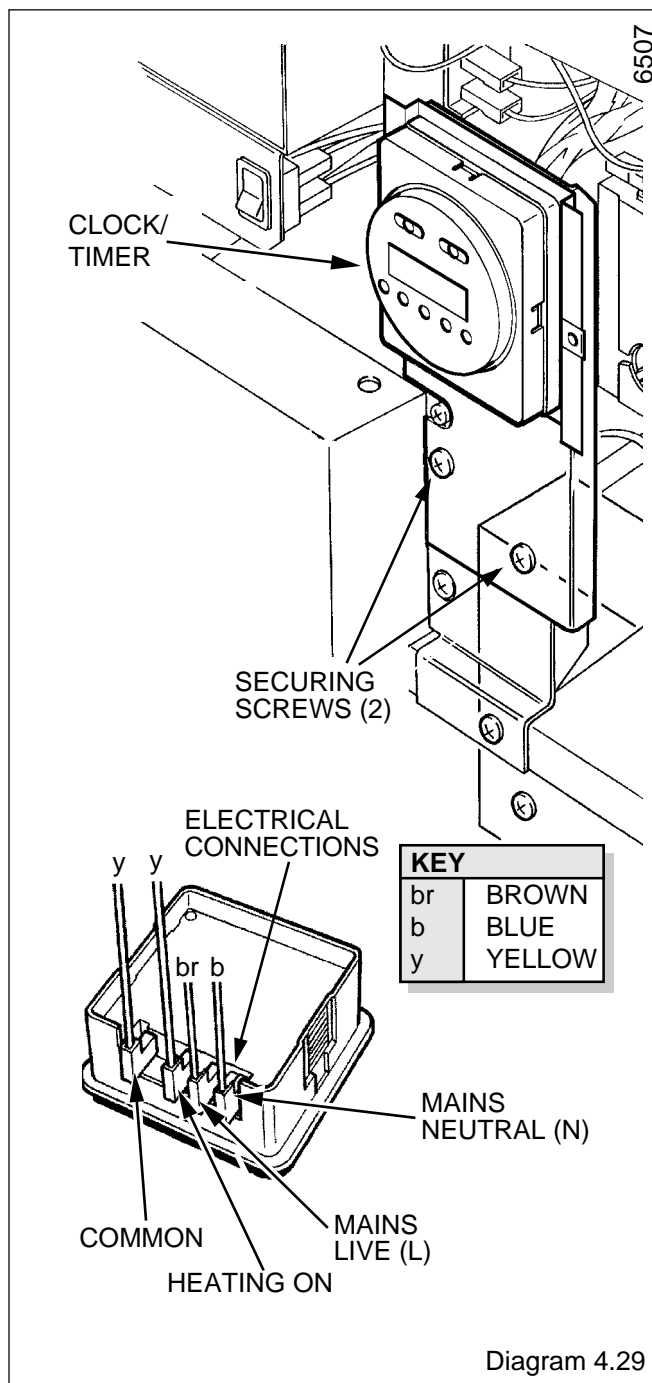

## 5 Spare Parts

### 5.1 Part Identification

The key number in diagram 5.1 and the first column of the list will help identify the spare part.

### 5.2 Ordering

When ordering any spare part, please quote the part number and the description from the list together with the model name and serial number information from the data label.

The data label is positioned on the inner case cover, see diagram 6.1 Installation Instructions.

Key No.	Part No	Description	GC No
1	452316	Fan assembly	278 416
2	205733	Main injector assembly (75e)	278 417
3	202631	Spark electrode	278 420
4	202632	Sensing electrode	278 421
5	800745	Boiler over heat cut off assy	278 413
6	432868	DHW high limit control assy	313 024
7	800134	Pressure gauge assembly	313 294
8	202253	Control board	375 724
9	202250	Central heating selector switch	382 813
10	202251	Control reset switch	375 724
11A	800504	Thermistor assembly-Domestic	278 135
11	800504	Thermistor assembly-Heating	278 135
12	800136	DHW switch assembly	313 277
13	202240	Fuse 2 T(630 mA) - not illustrated	-
14	202226	Fuse 1 (2AT) - not illustrated	278 136
15	800345	Water pressure switch assembly	313 767
16	800744	Gas valve	278 422
17	204536	Air pressure switch assy	278 419
18	800153	Automatic air vent assembly	313 285
19	800149	Safety valve assembly	397 677
20	208214	Water inlet filter	281 359
21	800322	Transformer	313 761
22	202252	C.V.I. Ignition module	375 736

# 5 Spare Parts

5270

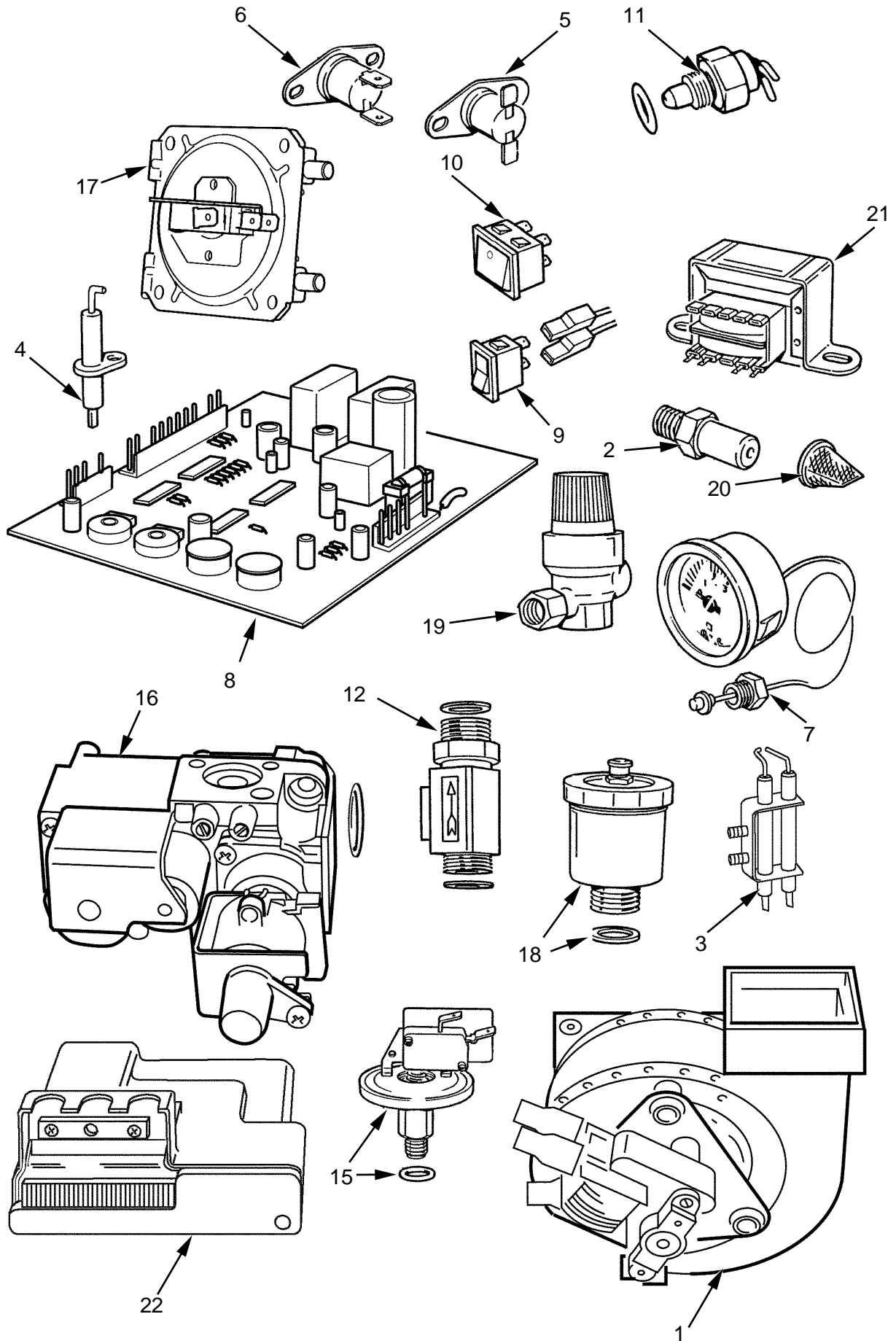

Diagram 5.1

*Because of our constant endeavour for improvement, details may vary slightly from those shown in these instructions.*