

Glow worm

Instructions for Use Installation and Servicing

To be left with the user

SWIFT FLOW

75

G.C. No. 47 313 14 Honeywell
G.C. No. 47 313 15 S.I.T

Fanned Flue Combination Boiler



This is a Cat I_{2H} Appliance

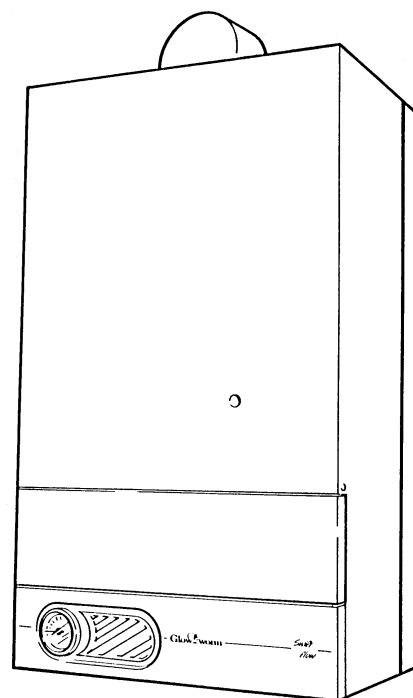

72903

The instructions consist of three parts, User, Installation and Servicing Instructions, which includes the Guarantee Registration Card. The instructions are an integral part of the appliance and must, to comply with the current issue of the Gas Safety (Installation and Use) Regulations, be handed to the user on completion of the installation.

Guarantee Registration

Thank you for installing a new Glow-worm appliance in your home.

Glow-worm appliances' are manufactured to the very highest standard so we are pleased to offer our customers' a Comprehensive First Year Guarantee.

In the center pages are to be found your Guarantee Registration Card, which we recommend you complete and return as soon as possible.

If this card is missing you can obtain a copy or record your registration by telephoning the Heatcall Customer Service number 01773 828100.

Our Guarantee gives you peace of mind plus valuable protection against breakdown by covering the cost of:

- All replacement parts**
- All labour charges**
- All call-out charges**

**REGISTER YOUR GLOW-WORM APPLIANCE
FOR 1ST YEAR GUARANTEE PROTECTION**

CALL 0181 380 2555

HEATCALL

Customer Services:

Tel: (01773) 828100

One Contact Local Service

Fax: (01773) 828070

Hepworth Heating Ltd.,

Nottingham Road, Belper, Derbyshire. DE56 1JT

General/Sales enquiries:

Tel: (01773) 824141 Fax: (01773) 820569

Important Information

Testing and Certification

This boiler is tested and certificated for safety and performance. It is therefore important that no alteration is made to the boiler, without permission, in writing, from Hepworth Heating Ltd.

Any alteration not approved by Hepworth Heating Ltd., could invalidate the certification, boiler warranty and may also infringe the current issue of the Statutory Requirements, see Section 1.4.

CE Mark

This boiler meets the requirements of Statutory Instrument No. 3083 The boiler (Efficiency) Regulations, and therefore is deemed to meet the requirements of Directive 92/42/EEC on the efficiency requirements for new hot water boilers fired with liquid or gaseous fuels.

Type test for purposes of Regulation 5 certified by: Notified body 0087.

Product/production certified by: Notified body 0087.

The CE mark on this appliance shows compliance with:

1. Directive 90/396/EEC on the approximation of the laws of the Member States relating to appliances burning gaseous fuels.
2. Directive 73/23/EEC on the harmonization of the Laws of the Member States relating to the electrical equipment designed for use within certain voltage limits.
3. Directive 89/336/EEC on the approximation of the Laws of the Member States relating to electromagnetic compatibility.

Substances Hazardous to Health

The adhesives and sealants used in this appliance are cured and give no known hazard in this state.

INSULATION PADS/CERAMIC FIBRE, GLASSYARN, MINERAL WOOL

These can cause irritation to skin, eyes and the respiratory tract.

If you have a history of skin complaint you may be susceptible to irritation. High dust levels are usual only if the material is broken.

Normal handling should not cause discomfort, but follow normal good hygiene and wash your hands before eating, drinking or going to the lavatory.

If you do suffer irritation to the eyes or severe irritation to the skin seek medical attention.

CONTENTS	DESCRIPTION	SECTION	PAGE No.
INSTRUCTIONS FOR USE	Introduction		3
	Clock Settings		4
	Lighting the Boiler		5
INSTALLATION INSTRUCTIONS	General Data	1	8
	Boiler Position	2	10
	Flue and Ventilation	3	10
	Heating System	4	12
	Domestic Hot Water System	5	14
	Installation Preparation	6	15
	Flue Preparation	7	17
	Gas and Water Connections	8	19
	Electrical Connections	9	20
	Boiler Fixing	10	22
	Commissioning	11	24
SERVICING INSTRUCTIONS	General Data	1	29
	Servicing	2	30
	Fault Finding	3	31
	Replacement Parts	4	40
	Spare Parts	5	55

Instructions for Use

Introduction

Please read these instructions and follow them carefully for the safe and economical use of your Combination boiler.

This boiler must have been installed by a competent person in accordance with the rules in force in the countries of destination.

Once the pilot has been lit and the controls set, the boiler is automatic in operation.

The Swift-flow combination boiler is able to provide room heating as part of a central heating system and domestic hot water direct from the cold water supply, without the need for secondary storage.

Your boiler will be fitted with either a Honeywell or SIT gas control valve. To check which one is fitted, look at the gas control knob.

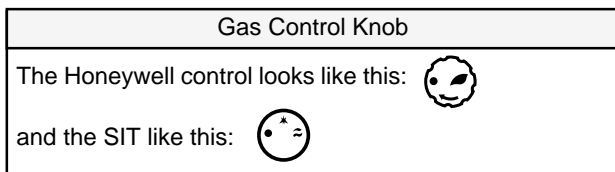

Also, it can be fitted with one of two makes of clock, which look like this:-

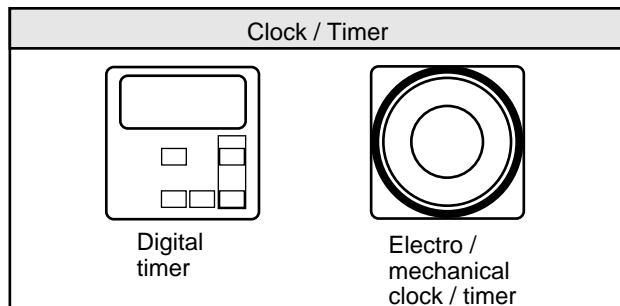

IMPORTANT NOTICE:

This boiler is for use only on G20 gas.

Gas Leak or Fault

If a gas leak or fault exists or is suspected, turn the boiler off and consult your local gas company or your local installation/servicing company.

Domestic Hot Water Temperature

NOTE. The mains water temperature in the winter is lower than in the summer.

The water temperature can be increased or reduced by adjusting the flow rate at the hot water draw off tap.

Boilers Installed in Compartments

If the boiler has been fitted into a compartment or cupboard, do not obstruct the compartment air supply vents.

Do not use the compartment for storage.

Electrical Supply

WARNING. The boiler must be earthed.

The boiler must be connected to a 240V~50Hz permanent supply.

Connection of the whole electrical system of the boiler and any heating system controls to the electrical supply, must be through one common isolator.

Isolation should preferably be by a double pole switched fused spur box. The fused spur box should be readily accessible and preferably adjacent to the appliance. It should be identified as to its use.

Alternatively a fused 3A 3 pin plug and shuttered unswitched socket may be used.

The colours of three core flexible cable are, blue - neutral, brown - live, green and yellow - earth.

As the markings on your plug may not correspond with these colours continue as follows:-

The wire coloured blue must be connected to the terminal marked "N" or "Black".

The wire coloured brown must be connected to the terminal marked "L" or "Red".

The wire coloured green and yellow must be connected to the terminal marked "E" or "Green" or the earth symbol \perp .

PVC flexible cable having a conductor size of 0.75mm² (24/0.20mm) must be used within the boiler casing to connect to the boiler.

Electrical Supply Failure

The boiler will not work without an electrical supply.

Normal operation of the boiler should resume when the electrical supply is restored but failure of the electrical supply may cause the pilot flame to go out.

Should this happen, wait until the supply is restored, or four minutes (which ever is the greater time). Allow the boiler to cool slightly and relight the pilot as described in "To Light the Boiler".

Reset any external controls, to resume normal operation of the central heating.

The digital timer has a lithium battery back up and will not need resetting.

Overheat Safety Cutoff

The boiler is fitted with a safety cutoff device to prevent damage through overheating. Should the main burner and pilot light go out, for no apparent reason, during normal use, allow the boiler and system to cool down, (waiting at least four minutes), relight the boiler as described in "To Light the Boiler".

If the problem persists, turn the boiler off and consult the local gas company or your installation/servicing company.

Instructions for Use

Setting Instructions for Electro/mechanical Clock - if fitted

This clock has a twenty four hour dial, that is, 1pm is 13.

To set the time, turn the whole face clockwise until the pointer is against the time of day.

To set any "Off" time, push the tappets outwards.

To set any "On" time, push the tappets inwards.

Time can be set either "On" or "Off" in fifteen minute segments.

Note. The clock supplied could be fitted with an override device, see diagram 1, which switches the clock programme "On" or "Off" permanently.

The switch will need to be repositioned to resume programmed working.

This is a 24 hour clock/timer, that is 1pm is 13:00, and has 8 "ON" and 8 "OFF" daily switching actions.

It is fitted with a lithium battery back up which protects the programme in the event of an electrical failure. The battery should have a life of several years.

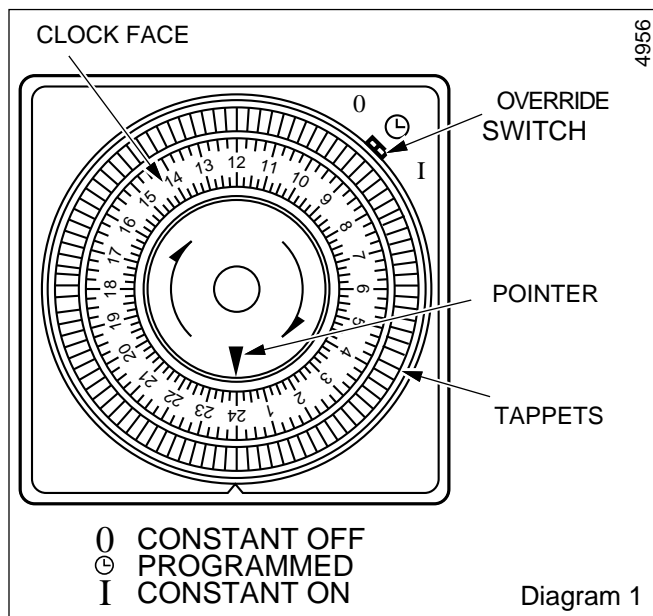

Setting Instructions for the 7 Day Digital Clock/Timer

This is a 24 hour clock/timer, that is 1pm is 13:00, and has 8 "ON" and 8 "OFF" daily switching actions.

It is fitted with a lithium battery back up which protects the programme in the event of an electrical failure. The battery should have a life of several years.

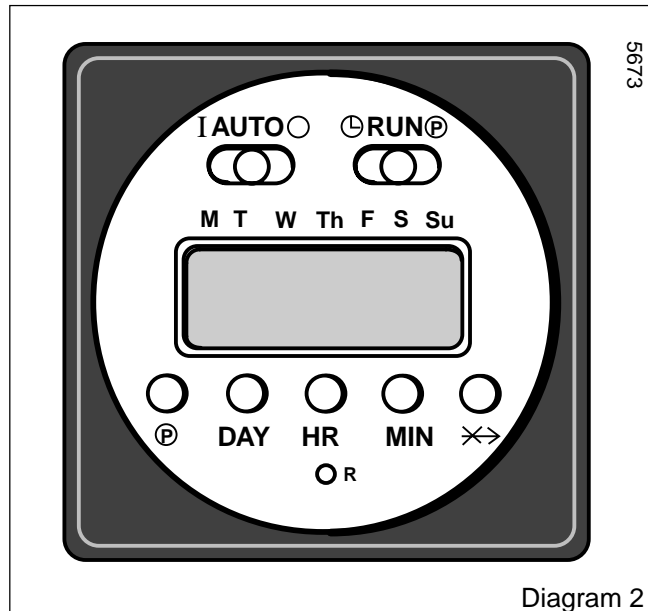

Setting the Clock

1. With both AUTO and RUN switches set to the central position, press R reset button, the display will flash.
2. Set RUN switch to .
3. Set day of week by pressing button DAY.
4. Set time of day by pressing buttons HR and MIN.
5. Set RUN switch to the central position, colon will flash, this indicates the clock is set.

With the clock set, the factory preset programme shown below will operate.

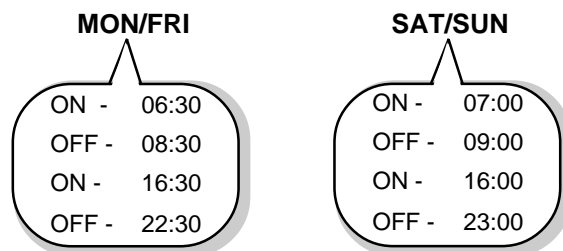

Setting Timed Programmes

With the clock set to the correct time, see SETTING THE CLOCK paragraphs 1-4, and then continue as follows:

1. Set RUN switch to , the display will indicate the 1st (ON) preset programme and the symbol .
2. Set day of week to be programmed by pressing the DAY button.

Note. The days can be selected individually or as groups: Mon-Fri., Mon-Sat., Mon-Sun., Sat/Sun.

An arrow will be displayed under the day or days selected.

3. Set time of day by pressing the buttons HR and MIN.

Instructions for Use

4. Press button **P** to confirm programmes, the display will indicate the 2nd (OFF) preset programme and subsequently, 3rd, 4th, 5th, 6th, 7th, 8th.

5. Repeat procedures 2, 3 and 4 until desired programmes are set.

Note. It is not a requirement to use the 8 on/off programmes.

6. Set the RUN switch the central position, your appliance will now operate at the programmed times.

General Notes.

With the AUTO switch in the I position the central heating will operated constantly ON.

With the AUTO switch in the O position the central heating will not operate.

Soft Override button indicated by the symbol $\times \rightarrow$, this function will override the current central heating programme for the next available.

ON time programmes are indicated by the symbol \odot .

To Light the Boiler - Honeywell

1. Check that all five isolating valves are open, the slots in line with the length of the valve, see diagram 3.

2. Open the door, by pushing at the side opposite to the hinge.

3. CAUTION. A sealed pressurised system must be filled and pressurised by a competent person.

Only light the boiler when you are sure that the system has been filled and pressurised. Check this by looking at the pressure gauge "A", diagram 4, it should read 0.7bar minimum.

4. Open a hot water tap, check that water flows, then close it.

5. If you are in any doubt about the boiler being filled with water contact your installation/servicing company or the local gas company.

6. Check that the electrical supply to the boiler is ON at the external isolator.

7. Fully push and hold down gas control knob "D". Press and release the piezo button "E" until the pilot burner lights, view through window in the front of the case. When the pilot burner is lit, keep knob "D" pushed in for a further 15 seconds then release. The pilot should remain alight.

8. IF THE PILOT GOES OUT NOW, OR ON ANY OTHER OCCASION, A SAFETY DEVICE PREVENTS IMMEDIATE RELIGHTING. WAIT AT LEAST FOUR MINUTES BEFORE ATTEMPTING TO RELIGHT.

9. If the pilot burner fails to remain alight, repeat instruction 7 but now hold down knob "D" for a little longer after the pilot has lit.

10. Check that the pilot is alight and stable.

11. Set switch "C", clock/timer (if fitted) and any remote controls as required.

Close the door.

In certain circumstances, a surge in water pressure may cause the appliance to operate momentarily, this will be indicated by the pump starting and the fan speed increasing. This is quite normal.

CAUTION. The permanent mains electrical supply to the boiler must be left on whilst the pilot flame is alight.

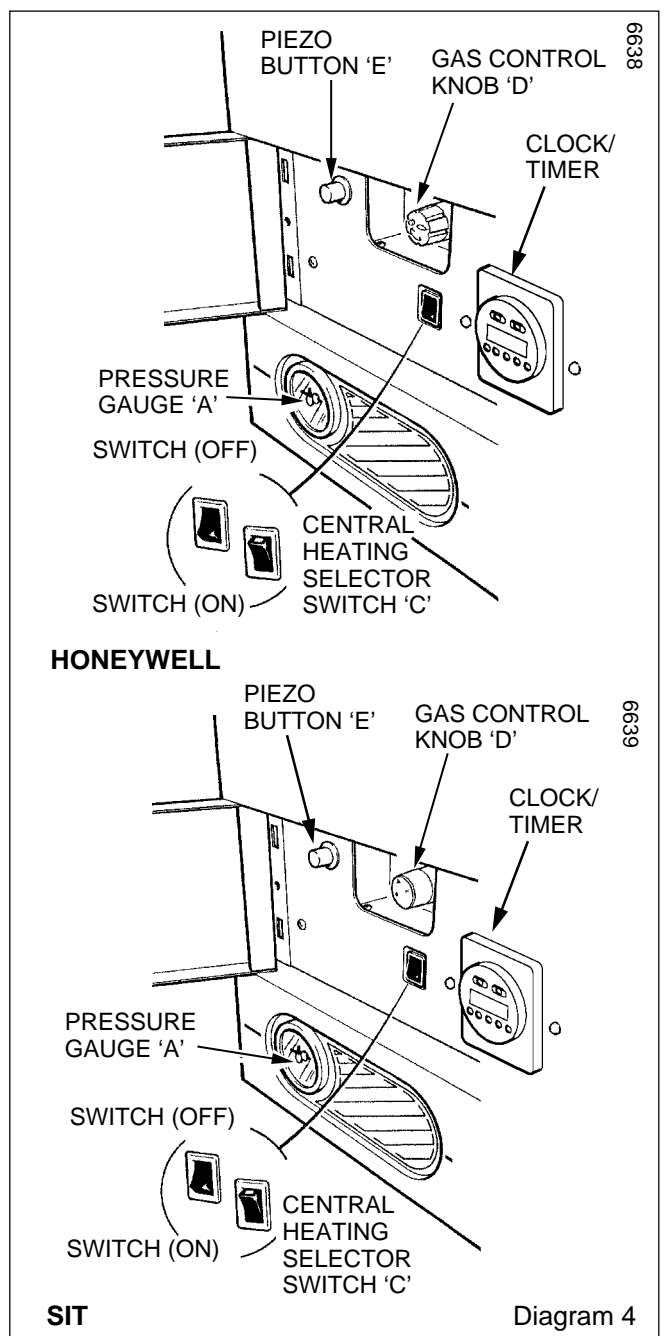
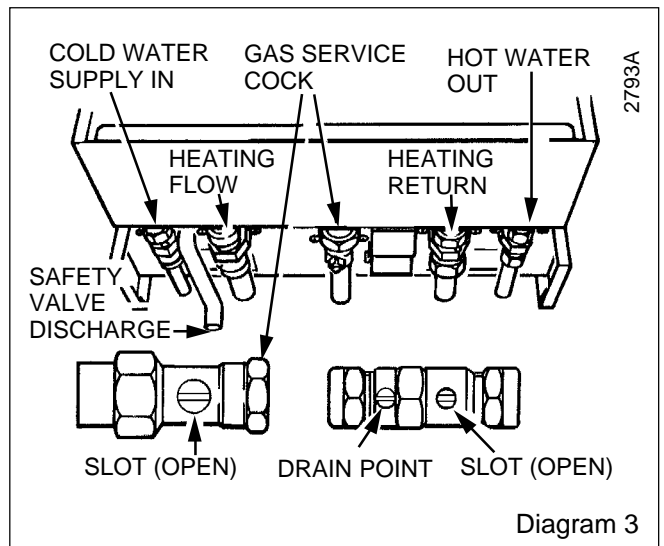

HONEYWELL

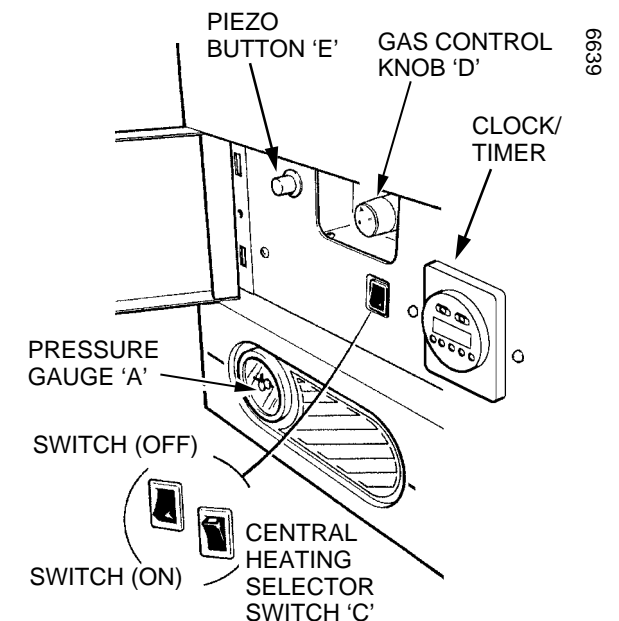



SIT

Instructions for Use

To Light the Boiler - SIT

1. Check that all five isolating valves are open, the slots in line with the length of the valve, see diagram 3.
2. Open the door, by pushing at the side opposite to the hinge.
3. CAUTION. A sealed pressurised system must be filled and pressurised by a competent person.

Only light the boiler when you are sure that the system has been filled and pressurised. Check this by looking at the pressure gauge "A", diagram 4, it should read 0.7bar minimum.

4. Open a hot water tap, check that water flows, then close it.
5. If you are in any doubt about the boiler being filled with water contact your installation/servicing company or the local gas company.
6. Check that the electrical supply to the boiler is ON at the external isolator.
7. The fan and pump will operate for about 30 seconds, after which the fan will then reduce speed and the pump stop until the boiler has been lit and the controls set.
8. Set switch "C" to "Off", see diagram 4.
9. Turn gas control knob "D" to  pilot/ignition position and push in. Press and release the piezo button "E" until the pilot burner is alight, look through the window in the front of the case. When the pilot burner is lit, keep knob "D" pushed in for a further 15 seconds and release. The pilot should remain alight.
10. IF THE PILOT GOES OUT NOW, OR ON ANY OTHER OCCASION, A SAFETY DEVICE PREVENTS IMMEDIATE RELIGHTING. WAIT AT LEAST FOUR MINUTES BEFORE ATTEMPTING TO RELIGHT.
11. If the pilot burner fails to remain alight, repeat instruction 9 but now hold down knob "D" for a little longer after the pilot has lit.
12. Check that the pilot is alight and stable.
13. Turn gas control knob "D" to '  ', main burner position.
14. Set switch "C" and any remote controls as required.

Close the door.

In certain circumstances a surge in water pressure may cause the appliance to operate momentarily, this will be indicated by the pump starting and the fan speed increasing. This is quite normal.

Central Heating Selector Switch

For central heating set switch "C" to "On" as shown in diagram 4, white flash showing. The main burner will light.

When the heating is controlled by a room thermostat and/or a time switch, switch "C" must be set "On", the white flash showing.

If a hot water tap is opened while the boiler is on for heating, the burner flame will increase in size and priority will be given to hot water. When the hot water tap is closed, the main burner flames will decrease in size but will remain alight until the boiler controls or any heating controls switch it off.

Which ever position switch "C" is in domestic hot water will be available.

To Turn the Central Heating Off

To turn the heating off for short periods, set switch "C" to "Off" as shown in diagram 4.

To turn on again set switch "On" so that the white flash shows, see diagram 4.

To Turn the Boiler Off - Honeywell

To turn the boiler off, isolate the boiler from the electrical supply. Turn gas control knob "D" clockwise to its stop and release. Control knob "D" will automatically return to the lighting position.

Follow the full instructions to relight.

To Turn the Boiler Off - SIT

To turn the boiler off, isolate the boiler from the electrical supply. Turn gas control knob "D" clockwise to '  ' and release.

Follow the full instructions to relight.

Domestic Hot Water Temperature

NOTE. The mains water temperature in the winter is lower than in the summer.

The water temperature can be increased or reduced by adjusting the flow rate at the hot water draw off.

Maintenance and Servicing

To ensure the continued efficient and safe operation of the appliance it is recommended that it is checked and serviced as necessary at regular intervals. The frequency of servicing will depend upon the particular installation conditions and usage, but in general once a year should be enough.

If this appliance is installed in a rented property there is a duty of care imposed on the owner of the property by the current issue of the Gas Safety (Installation and Use) Regulations, Section 35.

Servicing/maintenance should be carried out by a competent person in accordance with the rules in force in the countries of destination.

To obtain service, please call your installer or Heatcall (Glow-worm's own service organisation) using the telephone number behind the controls access door, see diagram 4.

Clearances

The boiler requires a clearance in front, below and at the sides of the casing for safety, servicing and maintenance access, see diagram 5.

Protection Against Freezing

If the boiler is to be out of use for any long periods during severe weather, it is recommended that the whole system, including the combination boiler, should be drained to avoid the risk of freezing.

If in doubt, contact you installation/servicing company for advice.

Draining and Filling

CAUTION. This boiler works in a pressurised system which must only be drained, refilled and pressurised by a competent person.

Note: If the pressure gauge indicates a loss of system pressure, that is, less than 0.7bar, YOU MUST CONTACT YOUR INSTALLER.

Instructions for Use

Pressure Relief Safety Valve

CAUTION. A pressure relief safety valve and discharge pipe is fitted to the boiler. This valve must not be touched. Should there be any discharge from the pipe, turn the boiler off, isolate from the electrical supply and contact your installation/servicing company.

Cleaning

WARNING. This appliance contains metal parts (components) and care should be taken when handling and cleaning with particular regard to edges.

The boiler casing can be cleaned using a mild liquid detergent with a damp cloth, then a dry cloth to polish.

Do not use any form of abrasive or solvent cleaner as you may damage the paint work

Boiler Casing

CAUTION. Do not remove or adjust the casing in any way, as incorrect fitting may result in incorrect operation or failure to operate at all. If in doubt seek advice from the local gas company or your installation/servicing company.

Replacement Parts

If replacement parts are required apply to your local supplier or British Gas.

Please quote the name of the appliance, Swift flow 75 with Honeywell or SIT gas control valve.

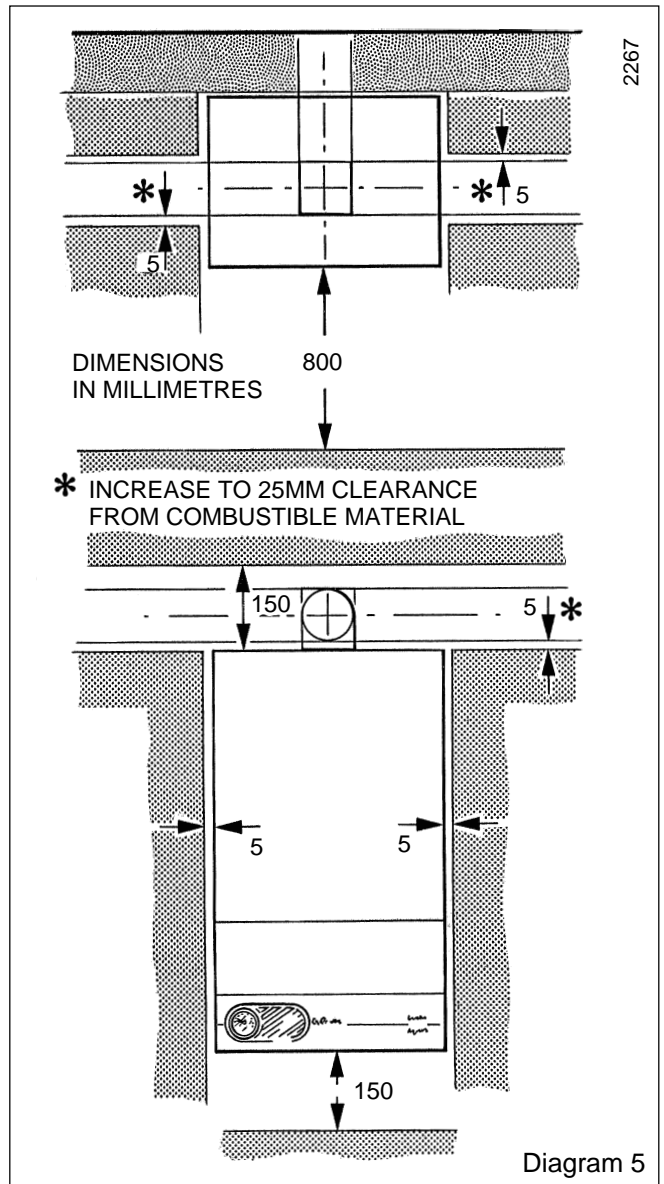

1 General Data

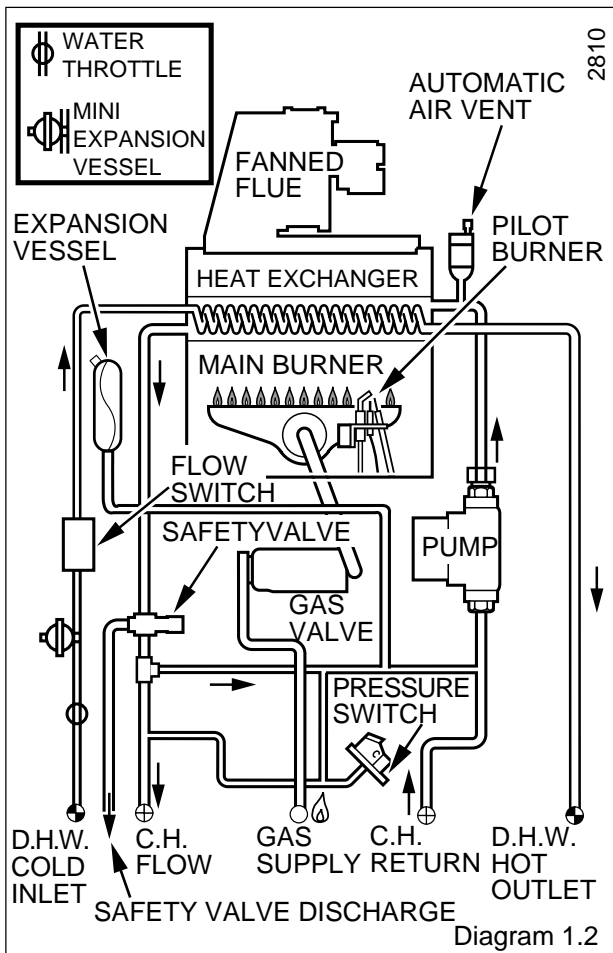
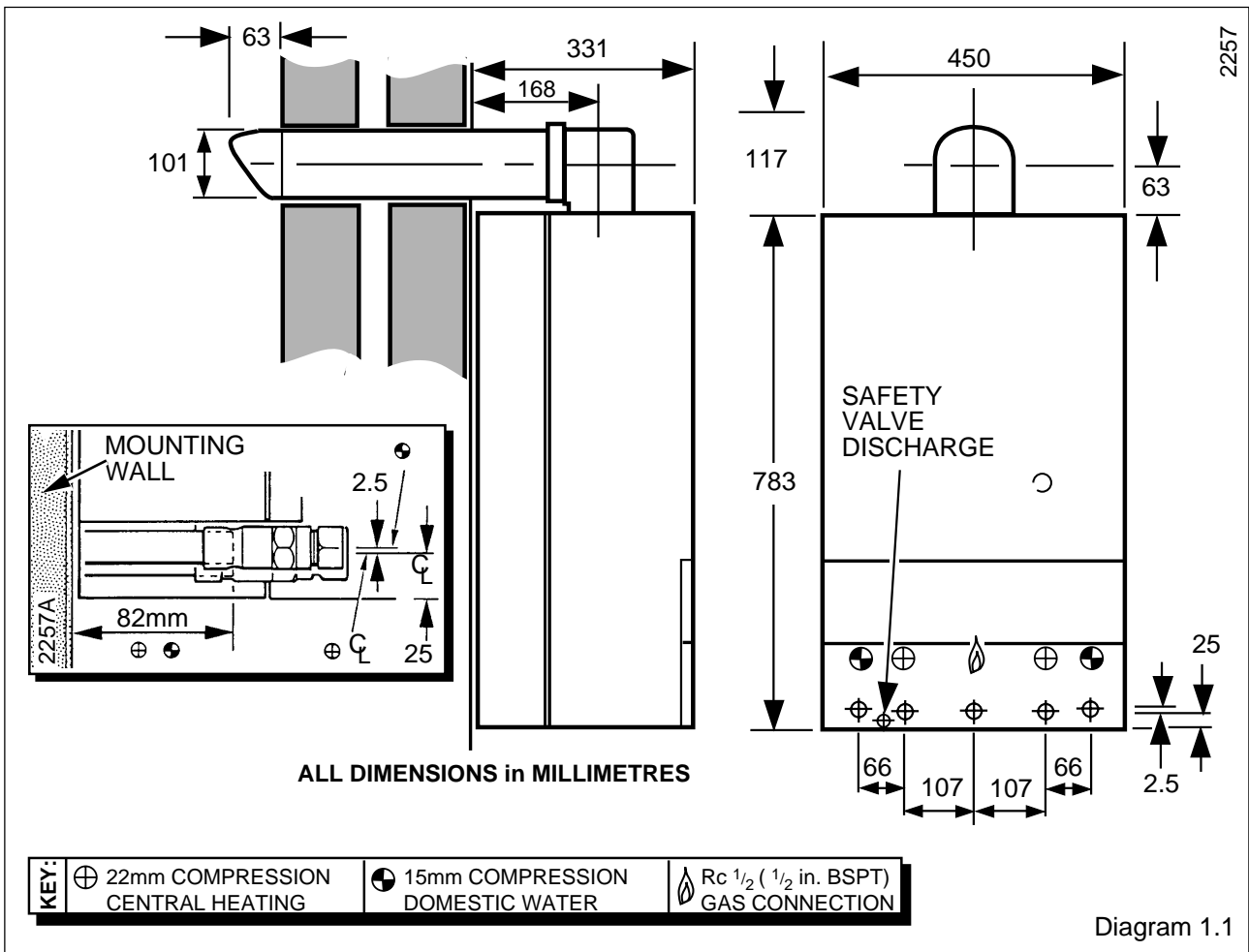

TABLE 1 HONEYWELL		C.H. MAX	D.H.W. MAX	MIN
NOMINAL	kW	18.2	27.5	10.6
HEAT INPUT (NETT)	Btu/h	62,030	93,750	36,167
NOMINAL	kW	16.1	22.0	8.8
HEAT OUTPUT	Btu/h	55,000	75,000	30,000
BURNER	mbar	8.2	16.1	2.5
PRESSURE	in.wg	3.4	6.5	1.0
APPROX. GAS RATE	m ³ /h	2.0	2.6	1.2
	ft ³ /h	69.5	92.5	42.1

TABLE 1 SIT		C.H. MAX	D.H.W. MAX	MIN
NOMINAL	kW	18.2	27.5	10.6
HEAT INPUT (NETT)	Btu/h	62,030	93,750	36,167
NOMINAL	kW	16.1	22.0	8.8
HEAT OUTPUT	Btu/h	55,000	75,000	30,000
BURNER	mbar	8.2	15.7	2.5
PRESSURE	in.wg	3.4	6.3	1.0
APPROX. GAS RATE	m ³ /h	2.0	2.6	1.2
	ft ³ /h	69.5	92.5	42.1

1 General Data

This boiler will be fitted with either a Honeywell or SIT Gas Valve. The valve used can be identified as shown.



1.1 Installation

Materials and equipment should be fit for their purpose and of suitable quality and workmanship.

1.2 Important Notice

This boiler is for use only on G20 gas.

1.3 Sheet Metal Parts

WARNING. When installing or servicing this boiler care should be taken when handling the edges of sheet metal parts to avoid any possibility of personal injury.

1.4 Requirements

The installation of this boiler must be carried out by a competent person in accordance with the rules in force in the countries of destination.

Manufacturer's instructions, supplied.

Manufacturer's instructions must not be taken as overriding statutory requirements.

1.5 Data Label

The data label is at the top right hand side of the inner case.

1.6 Data

Weight	47.2kg (104lb)
Gas connection	Rc ¹ / ₂ (1/2in BSP)
Heating Flow and Return	22mm compression
D.H.W Inlet and Outlet	15mm compression (Ball valves are incorporated in water and gas connections plus a drain point on all water connections).
Safety Valve	preset 3bar (43.5lbf/in ²)
Safety Valve Discharge	15mm compression
Water Content	1.74Litre (0.38gall)
Expansion Vessel	
Capacity	8Litre (1.76gal)
Heating Cold Fill	
Pressure	0.7bar (10.1lbf/in ²) minimum
D.H.W Working Pressure	0.5 to 10bar (7.25 to 188lbf/in ²)
Maximum Heating System Water Content	119Litre (26.2gall) (Larger systems will require an additional expansion vessel, refer to Section 4).
Electrical Supply	240V~50Hz
Electrical Rating	150W, fused 3A

1.7 Gas Supply

The gas installation shall be in accordance with the rules in force in the countries of destination.

The supply from the governed meter must be of adequate size to provide a steady inlet working pressure of 20mbar (8in wg) at the boiler.

1.8 Electrical Supply

WARNING. This boiler must be earthed.

All system components shall be of an approved type.

The installation shall be in accordance with the rules in force in the countries of destination.

Connection of the whole electrical system of the boiler and any heating system controls to the electrical supply, must be through one common isolator.

Isolation should be by a double pole switched fused spur box, having a minimum contact separation of 3mm in each pole. The fused spur box should be readily accessible and preferably adjacent to the appliance. It should be identified as to its use.

Alternatively, a fused 3A 3pin plug and unswitched socket may be used, provided they are not used in a room containing a bath or shower.

The mains supply cable and other cables connected to the boiler must be the PVC flexible type of at least 0.75mm² (24/0.20mm).

2 Boiler Position

2.1 Location

This boiler must be installed in accordance with the rules in force in the countries of destination.

This boiler is not suitable for fitting outside.

Any electrical switch must be positioned so that it cannot be touched by a person using the bath or shower.

The boiler must be mounted on a flat wall which is sufficiently robust to take its weight, refer to Section 1, "Data".

If the location of the boiler or any part of the system is subject to severe cold weather conditions, it is recommended that a frost thermostat is fitted. Any part of the system that may be vulnerable to freezing must be protected.

If the boiler is to be fitted into a cupboard, compartment or unusual location, special procedures are necessary.

Make sure that the cupboard or compartment air vents are positioned to be clear of obstructions at all times, refer to Section 3, Cupboard/Compartment Ventilation.

2.2 Clearances

The boiler should be positioned so that at least the minimum operational and servicing clearances are provided, see diagram 5 Instructions for Use. Additional clearances may be required around the boiler for installation.

3 Flue and Ventilation

3.1 Flue

The flue must be installed in accordance with the rules in force in the countries of destination.

3.2 Flue Position and Length

The air and flue ducting connect to the top of the boiler using the elbow which can be positioned in one of three possible directions:

Rearward, left or right.

The standard flue is able to provide the duct length range shown in diagram 3.1 for a rear flue or diagram 3.2 for a side flue.

If a longer flue duct is required, do not extend the ductings.

A 1, 2 or 3metre flue system and terminal must be used and can be supplied. This is able to provide the duct length range shown in diagram 3.3 for rear flue or diagram 3.4 for a side flue.

To make a neat finish to the flue outlet a flue collar kit, part No. 443286, with instructions, is available.

The use of this collar will mean that the flue lengths will need to be altered, full instructions are given in the kit.

3.3 Terminal Position

The minimum acceptable siting dimensions for the terminal from obstructions, other terminals and ventilation openings are shown in diagram 3.5.

The terminal must be exposed to the external air, the position allowing free passage of air across it at all times.

Car port or similar extensions of a roof only, or roof and one wall, require special consideration with respect to any openings, doors, vents or windows under the roof. Care is required to protect the roof if made of plastic sheeting. If the car port comprises of a roof and two or more walls seek advice from the local gas undertaking before installing the boiler.

If the terminal is fitted within 600mm below plastic guttering, an aluminium shield 1500mm long should be fitted immediately beneath the guttering or eaves. If the terminal is fitted within 450mm below painted eaves or a painted gutter, an aluminium shield 750mm long should be fitted immediately beneath the guttering or eaves.

3.4 Internal Access Flue

The flue can be installed from inside the building, when access to the outside wall face is not practicable. An internal access kit is provided in the standard carton.

3.5 Timber Frame Buildings

If the boiler is to be installed in a timber frame building seek advice from the local gas undertaking or from Hepworth Heating Ltd.

TABLE 2		
Position of Air Vent	Air from Room or Internal space	Air Direct from Outside
High Vent	248cm ² 38in ²	124cm ² 19in ²
Low Vent	248cm ² 38in ²	124cm ² 19in ²

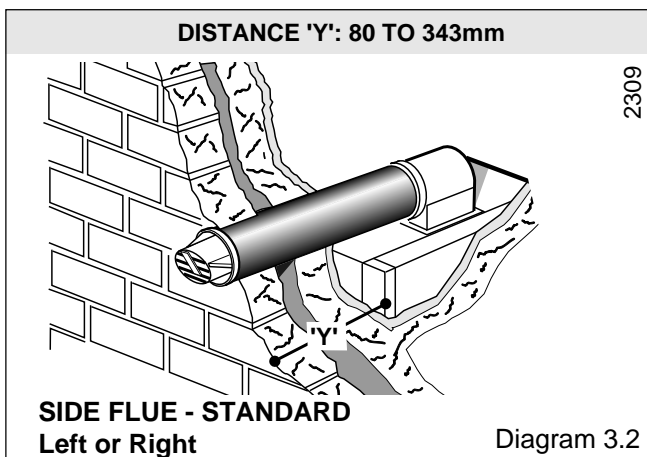
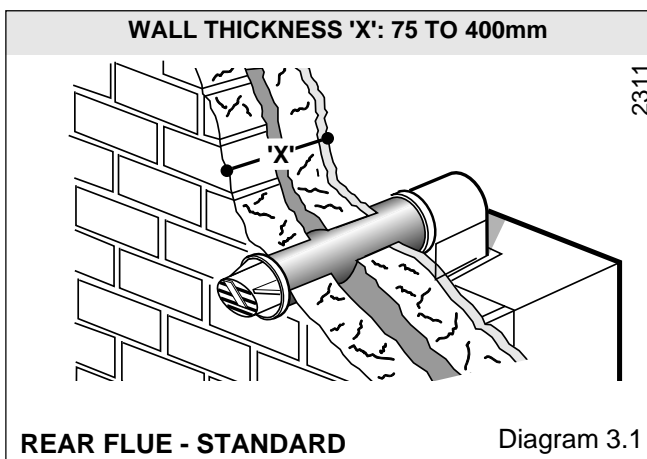

3 Flue and Ventilation

1m DISTANCE 'X': 75 TO 898mm
 2m DISTANCE 'X': 75 TO 1898mm
 3m DISTANCE 'X': 75 TO 2890mm

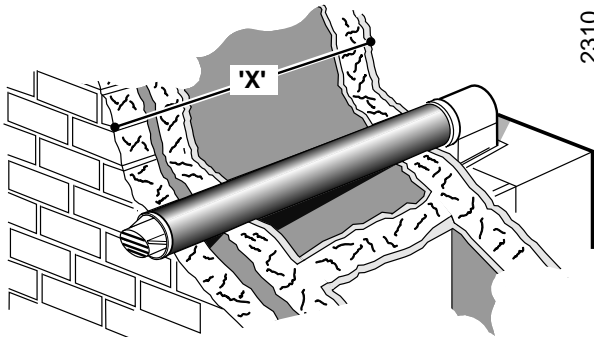

REAR FLUE - LONG

Diagram 3.3

1m DISTANCE 'Y': 80 TO 833mm
 2m DISTANCE 'Y': 80 TO 1833mm
 3m DISTANCE 'Y': 80 TO 2833mm

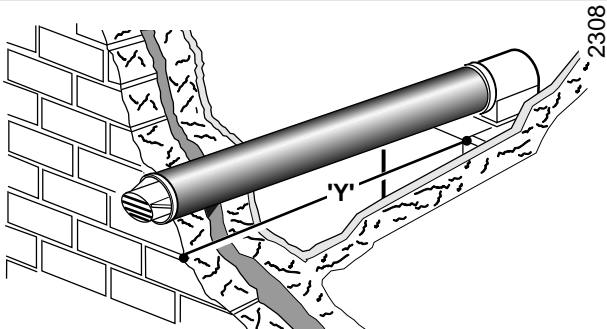

SIDE FLUE - LONG
 Left or Right

Diagram 3.4

3.6 Terminal Guard

A terminal guard is required if persons could come into contact with the terminal or the terminal could be subject to damage.

If a terminal guard is required, it must be positioned to provide a minimum of 50mm clearance from any part of the terminal and be central over the terminal.

The guard should be similar to that shown in diagram 3.6 and can be bought from:

Tower Flue Components Ltd
 Morley Road
 Tonbridge
 Kent. TN9 1RA

their type K3.

3.7 Room Ventilation

Ventilation must be provided in accordance with the rules in force in the countries of destination.

The boiler is room sealed, so where the boiler is fitted in a room or space, a permanent air vent is not required.

3.8 Cupboard/Compartment Ventilation

If the boiler is to be fitted in a cupboard or compartment, permanent high and low level air vents must be provided for ventilation. The vents must have at least the effective areas shown in Table 2.

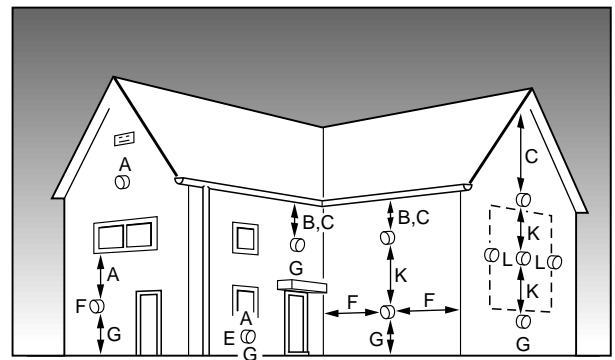

UNDER CAR PORT etc.

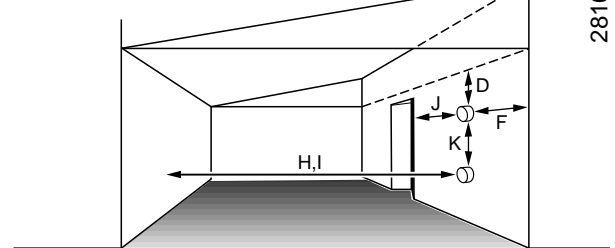

MINIMUM SITING DIMENSIONS FOR FANNED FLUE TERMINALS POSITION

MINIMUM SPACING

	MM
A DIRECTLY BELOW AN OPENABLE WINDOW, AIR VENT, OR ANY OTHER VENTILATION OPENING	300
B BELOW GUTTER, DRAIN/SOIL PIPE	75
C BELOW EAVES	200
D BELOW A BALCONY OR CAR PORT	200
E FROM VERTICAL DRAIN PIPES AND SOIL PIPES	75
F FROM INTERNAL OR EXTERNAL CORNERS	300
G ABOVE ADJACENT GROUND OR BALCONY LEVEL	300
H FROM SURFACE FACING THE TERMINAL	600
I FACING TERMINALS	1200
J FROM OPENING (DOOR/WINDOW) IN CAR PORT INTO DWELLING	1200
K VERTICAL FROM A TERMINAL	1500
L HORIZONTALLY FROM A TERMINAL	300

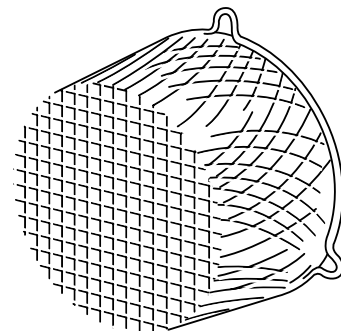
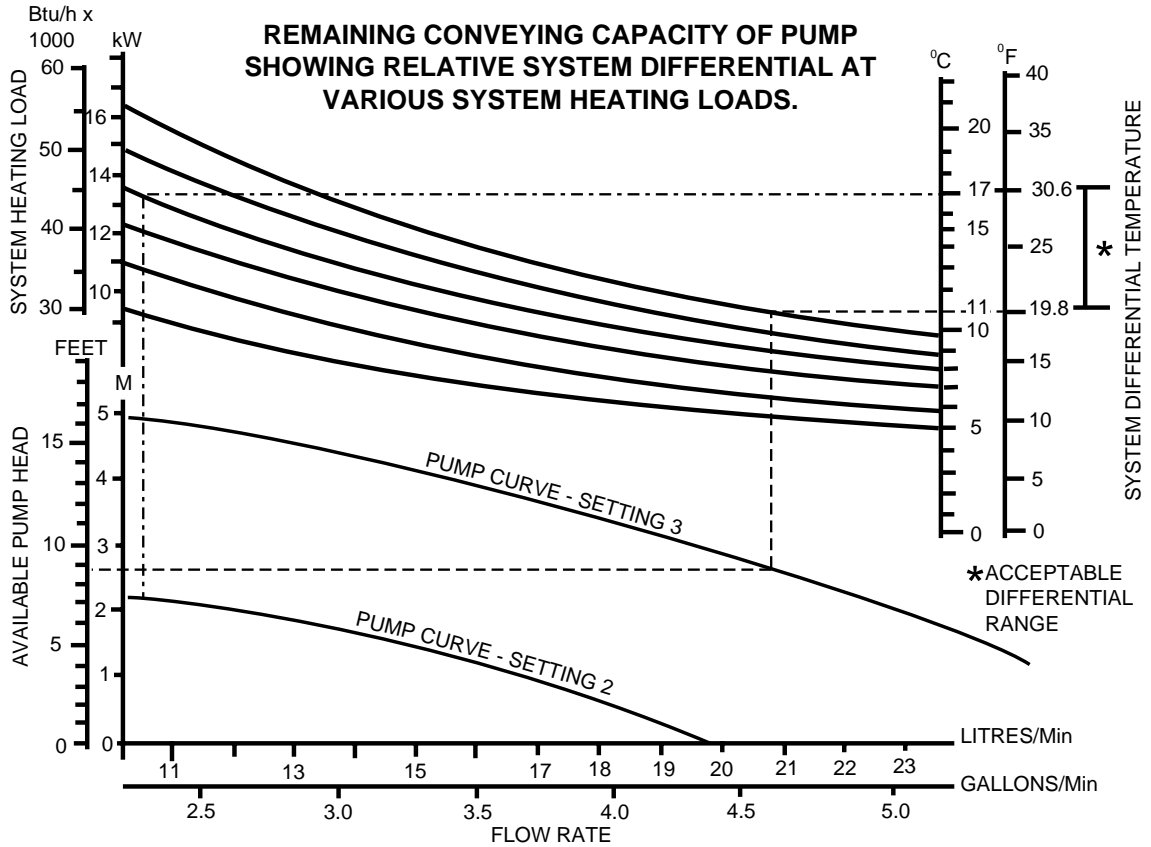

Diagram 3.5

4 Heating System

5947



GRUNDFOS

Diagram 4.1

5948

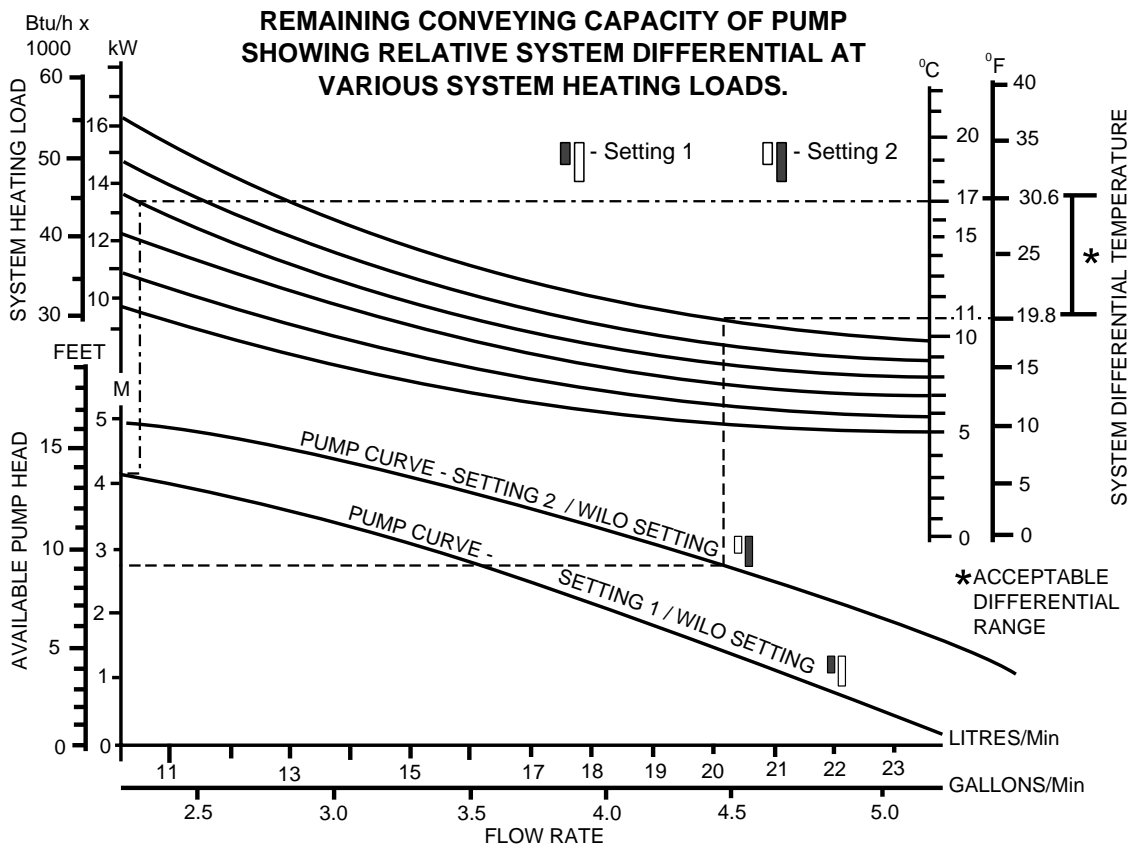

WILO

Diagram 4.1A

4 Heating System

4.1 General Notes

The boiler is intended for use in a sealed system only.

4.2 Safety Valve

The safety valve is an integral part of the boiler.

It cannot be adjusted but has a manual test device.

4.3 Pressure Gauge

A pressure gauge is incorporated into the boiler to indicate the system pressure.

The gauge has a cold fill set pointer.

4.4 Pump

The circulation pump is integral with the boiler.

The remaining circulating pressure head available from the boiler is shown in diagram 4.1, Grundfos or diagram 4.1A, Glow-worm Wilo.

4.5 Expansion Vessel

The boiler has an integral expansion vessel with a capacity of 8Litres, (1.76gall). If the system water content exceeds the maximum quoted in Section 1, Data, an additional vessel should be connected into the system as close as possible to the central heating return connection of the boiler, see diagram 4.2.

The pressure shall not be less than the static head at the point of connection, that is, the height of the top point of the system above the expansion vessel.

4.6 Flow Rate

A valve must be incorporated in the main flow or return of the system, valve "A" shown in the flow diagram 4.2. This valve must be lockable and positioned so that inadvertent closure or unauthorised interference is not possible. The design differential can be between 11°C (20°F) and 17°C (30°F), dependent upon the system resistance and the available pump head.

Grundfos Pump

The pump adjuster should normally be left at maximum (3) but in some cases it is permissible to adjust the pump to a lower setting (2), see diagram 4.1.

To use diagram 4.1 start with the required heating system load.

In the example shown the maximum boiler output has been chosen, 16.1kW (55,000Btu/h).

Draw a horizontal line from the required system differential temperature axis to intersect the curve.

In the example 11°C (19.8°F) has been chosen, shown - - - -. At the point of intersection draw a vertical line to cross the pump curve, from this point draw a further horizontal line to determine the available pump head. In the example 2.7m (9ft) is available. A greater pump head can be achieved by choosing a higher system differential temperature, up to a maximum of 4.6m (15ft) at a system differential of 17°C (30.6°F). The system must be designed such that the available pump head is not exceeded.

If the heating system load is less than 13.2kW (45,000Btu/h) then it is permissible to adjust the pump setting to (2), shown - - - -. This results in an available pump head of 2.1m (7ft). This is the maximum that can be achieved with the pump at this setting.

Glow-worm Wilo Pump

The pump adjuster should normally be left at maximum (2) but in some cases it is permissible to adjust to a lower setting (1), see diagram 4.1A.

To use diagram 4.1A start with the required heating system load.

In the example shown the maximum boiler output has been chosen, 16.1kW (55,000Btu/h).

Draw a horizontal line from the required system differential temperature axis to intersect the curve. In the example 11°C (19.8°F) has been chosen, shown ———. At the point of intersection draw a vertical line to cross the pump curve. From this point draw a further horizontal line to determine the available pump head. In the example 2.7m (9ft) is available. A greater pump head can be achieved by choosing a higher system differential temperature, up to a maximum of 4.6m (15ft) at a system differential of 17°C (30.6°F). The system must be designed such that the available pump head is not exceeded.

If the heating system load is less than 13.2kW (45,000Btu/h) then it is permissible to adjust the pump setting to (1), shown - - - - -. This results in an available pump head of 4.2m (13ft9in). This is the maximum that can be achieved with the pump at this setting.

4.7 Bypass

It is essential that a bypass is fitted in all installations, 22mm o.d. minimum. The bypass must have a lockable valve "B" in diagram 4.2, incorporated in a position so that inadvertent closure or unauthorised interference is not possible.

The bypass MUST be fitted before any system control. A radiator bypass is NOT recommended.

4.8 Make-up

Provision should be made for replacing water lost from the system using a make up bottle mounted in a position higher than the top point of the system, connected through a non-return valve to the return side of the heating circuit, see diagram 4.2.

Alternatively, provision for make-up can be made by pre-pressurisation of the circuit

4.9 Filling Sealed Systems

Provision for filling the system at a low level must be made. Three methods of filling are shown in diagram 4.3.

There must be no permanent connection to the mains water supply, even through a non-return valve.

NOTE: It is important that fittings used for connection to potable water comply with the water undertakers requirements.

4.10 Corrosion Inhibitor

If an inhibitor is to be used in the system, contact the inhibitor manufacturer so that they can recommend their most suitable product.

When fitting the boiler into an existing system, special care should be taken to drain the entire system, including radiators, then thoroughly cleaning out before fitting the boiler whether or not adding an inhibitor.

4 Heating System

4.11 Draining

A draining tap must be provided at the lowest points of the system, which will allow the entire system to be drained. An additional draining tap **MUST** be fitted close to the boiler.

The flow and return isolation valves are provided with drain points for boiler heat exchanger drainage.

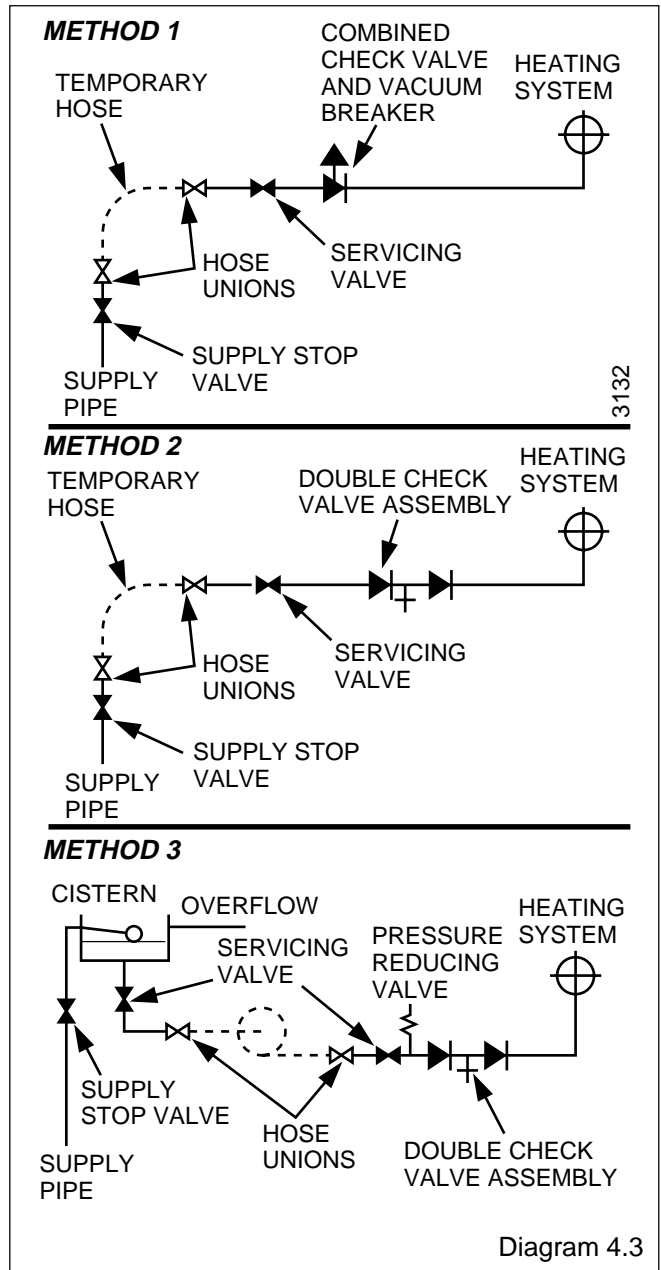
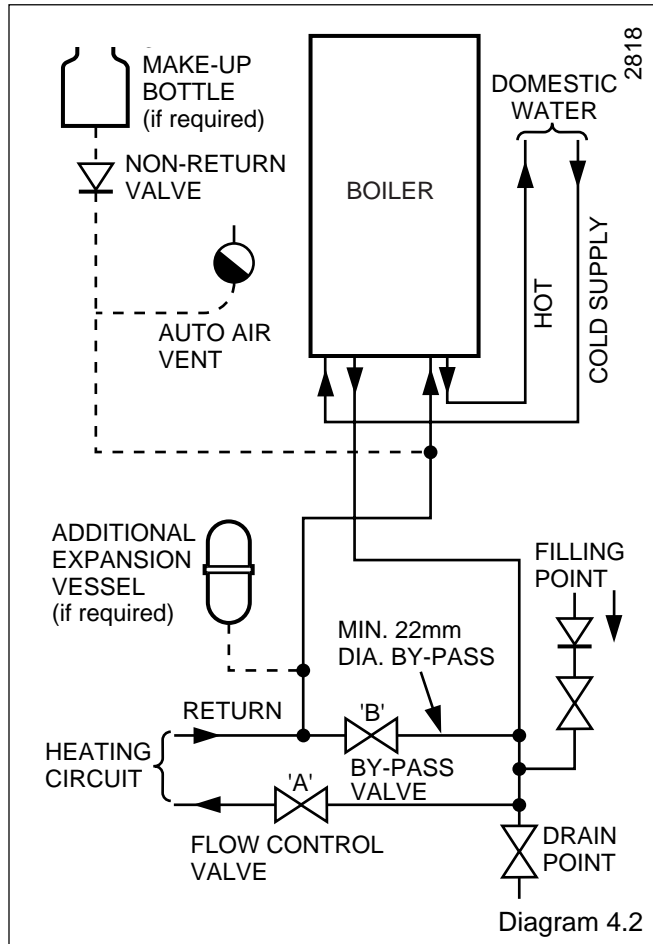

5 Domestic Hot Water System

5.1 General

The domestic hot water service must be in accordance with the rules in force in the countries of destination.

5.2 Water Pressure

For the minimum and maximum working pressures of the domestic hot water circuit of the boiler refer to Section 1.6 Data.

If the cold water supply pressure exceeds the maximum, a governor must be fitted in the supply to the boiler to reduce the pressure to within the limits given.

5.3 "Hard" Water Areas

In areas where the water is "hard", more than 200mg/litre, it is recommended that a proprietary scale reducer is fitted in the cold water supply to the boiler. Check the total water "hardness", using the kit supplied, in the door, following the instructions given. Consult the local water company for additional advice.

A double check valve assembly must be fitted upstream of the scale reducer. For the relative position of the scale reducer and pressure reducing valve, if required, refer to the manufacturer's instructions.

6 Installation Preparation

6.1 Unpacking

Remove the top carton and cut out the flue template from the inner flap.

Open the control door, see diagram 6.1.

Remove the two screws securing the outer case and then lift it at the top and pull it forwards and off.

Remove the cover of the inner case, secured with four screws, see diagram 6.2.

Disconnect the gas service cock union and the front unions of the isolation valves, see diagram 6.3.

Slightly loosen the clips of the gas service cock and the isolating valves.

Remove the two boiler securing screws then remove the boiler from the mounting frame, by pulling the studs from the clips and unhooking it at the top.

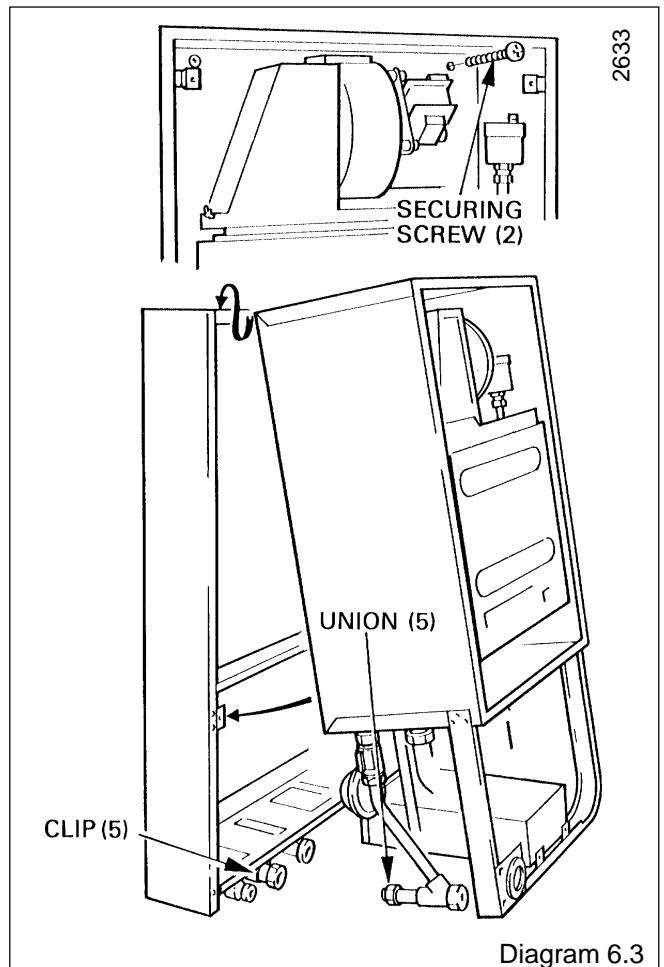
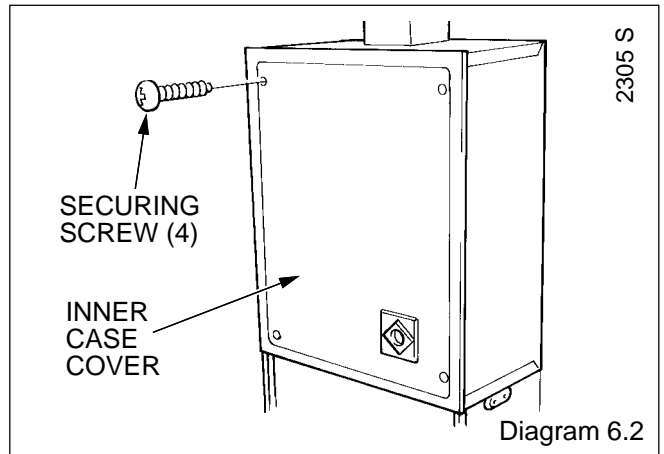
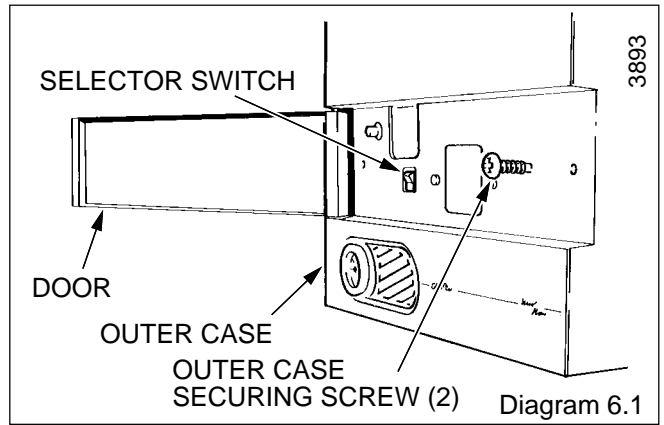

6 Installation Preparation

6.2 Marking

The boiler mounting frame is the same width as the boiler but the flue connection sticks out above it.

Place the boiler mounting frame on the wall in the required position, see diagram 2.1 to maintain minimum clearances. Make sure that the isolation valves are at the bottom facing forwards and that the frame top is horizontal, then mark the four wall fixing points through the holes in the two horizontal straps.

Position the flue template on the wall, the arrow points on the centres of the two upper fixing points previously marked, see diagram 6.4 which also shows dimensions.

For rear flue, mark the rear flue position as required, centre and/or diameter.

For a side flue, mark the horizontal flue centre line at the sides of the template. Extend the flue centre line horizontally left or right to the internal corner where the flue is required to exit to outside. Mark the position of the circular hole, on the flue exit wall, using the dimensions given in diagram 6.5.

From the flue position marks, check that the flue terminal will be in a suitable position, see diagram 3.6.

6.3 Flue Hole Cutting

Cut the hole horizontally in the wall, to the diameter shown in diagram 6.4, using, preferably, a core drill.

After cutting the hole, check that it will accept the wall sleeve.

6.4 Wall Sleeve

Note. The wall sleeve should be used for all installations.

Place the wall sleeve into the hole, flush with the outside wall face and seal around the sleeve to make it weatherproof on the outside and internally "good".

Access to the outside is possible through the sleeve.

If the sleeve is too long, cut it to the same length as the wall thickness.

For thicknesses over 300mm, the wall sleeve must be fitted flush with the outside wall face. Make good the external wall face, leave the internal wall face until later.

6.5 Boiler Mounting Frame Fixing

Position the flue template over the flue hole and check the position of the wall fixing points. Mark the position of the fixing holes again, if required.

Drill the four fixing holes and insert wall plugs to suit No.10x50mm long screws.

Secure the boiler mounting frame to the wall using No.10x50mm long screws.

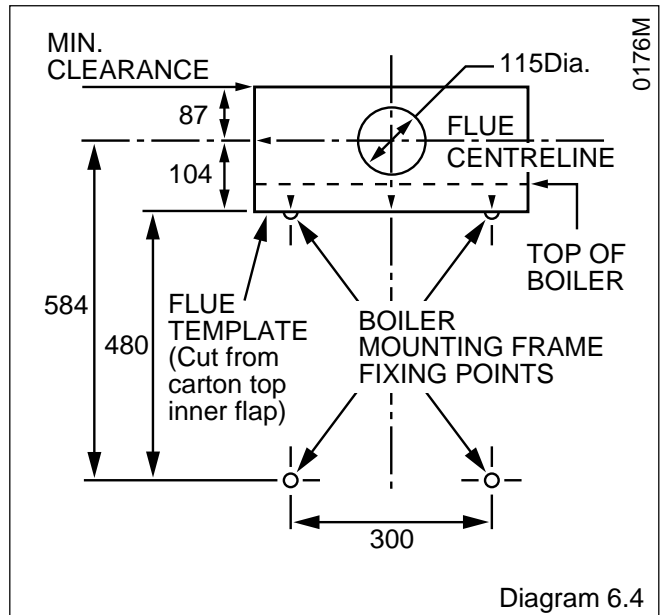

Diagram 6.4

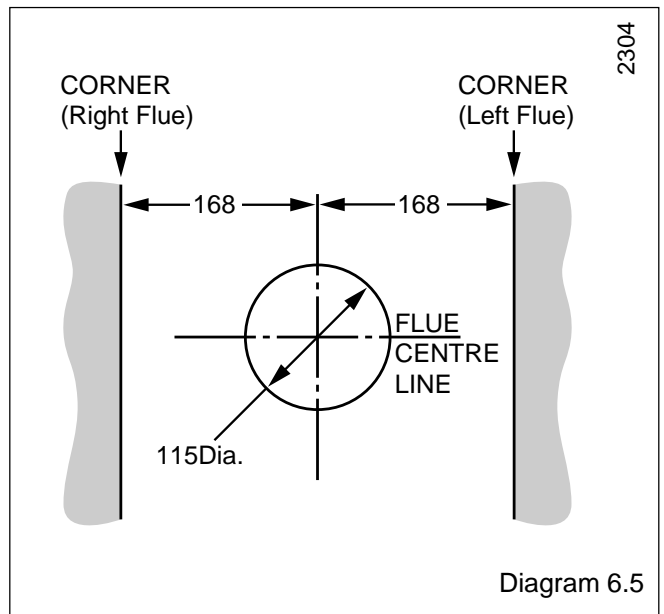

Diagram 6.5

7 Flue Preparation

7.1 Flue Length

For a rear flue, measure the distance from the outside wall face to the boiler mounting wall. Check that the flue length will be suitable, see diagram 3.1 for a standard flue system or diagram 3.3 for a 1, 2 or 3 metre flue system.

For a side flue, measure the distance from the outside wall face to the side of the boiler mounting frame. Check that the flue length will be suitable, see diagram 3.2 for a standard flue system or diagram 3.4 for a 1, 2 or 3 metre flue system.

All flue systems are installed in a similar manner to the standard flue.

Note: For all 1, 2 or 3 metre flues make sure that the flue duct is cut at the opposite end to the fixed spacer.

7.2 Rear Flue

Mark the air duct assembly and the flue duct at the lengths shown in diagram 7.1 and 7.2, then cut to length, cutting square and removing any burrs.

7.3 Side Flue

Mark the air duct assembly and the flue duct at the lengths shown in diagram 7.1 and 7.3 then cut to length, cutting square and removing any burrs.

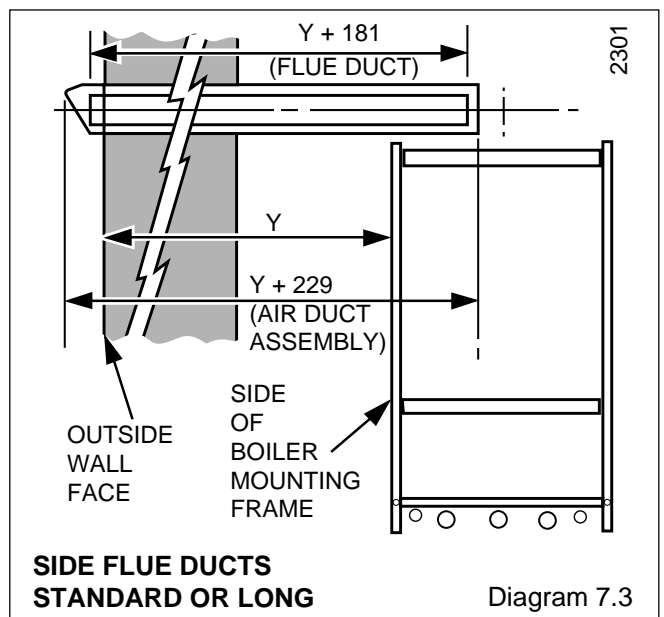
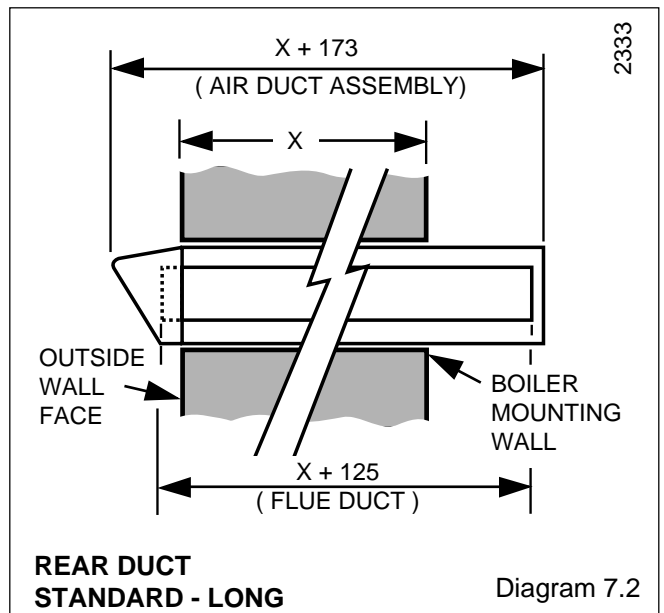
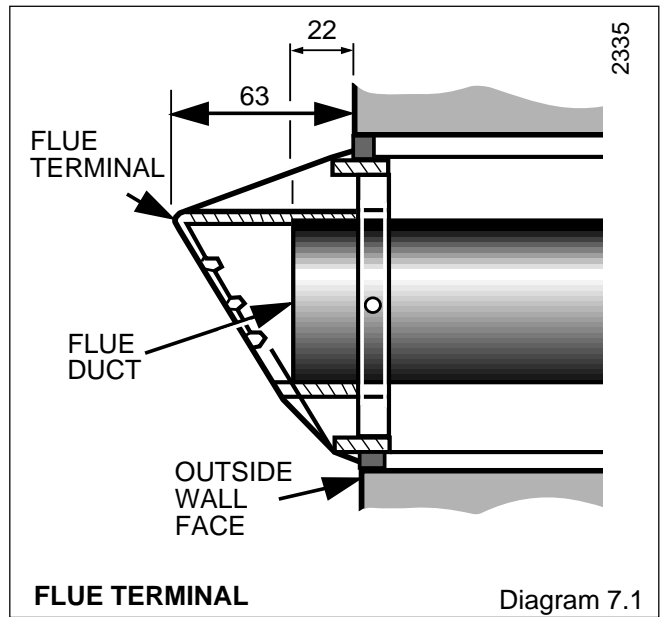

7 Flue Preparation

7.4 Air Duct

Locate the flue duct and air duct in the flue elbow, making sure that the flue duct is located in the flue terminal and the flue elbow but is free to move to allow for expansion.

Check that the flue terminal is in the correct position and sticking out the correct distance from the outside wall face, see diagram 7.1 and appropriate diagram 7.2 or 7.3.

Drill a hole, diameter as shown in diagram 7.4, in each side of the air duct, through the holes in the flue elbow. Secure the air duct to the flue elbow using the two screws supplied in the loose items pack.

Seal around the joint between the air duct and the flue elbow using the tape provided in the loose items pack.

If the boiler is not to be fitted for some time, cover the hole in the wall.

7.5 Internal Access Flue

If access to the outside wall surface is not practical, the flue system can be installed from inside using the internal access wall sleeve and seal. A core drilled hole, diameter as shown in diagram 7.5 is required for the sleeve.

Place the wall sleeve into the hole, flush with the outside wall face and seal around the sleeve to make it weatherproof on the outside and internally "good". Access to the outside is possible through the sleeve. If the sleeve is too long, cut it to the same length as the wall thickness.

Stick the self-adhesive seal, supplied in the loose items pack, around the air duct, in a position so that it will be flush with the outside wall when installed.

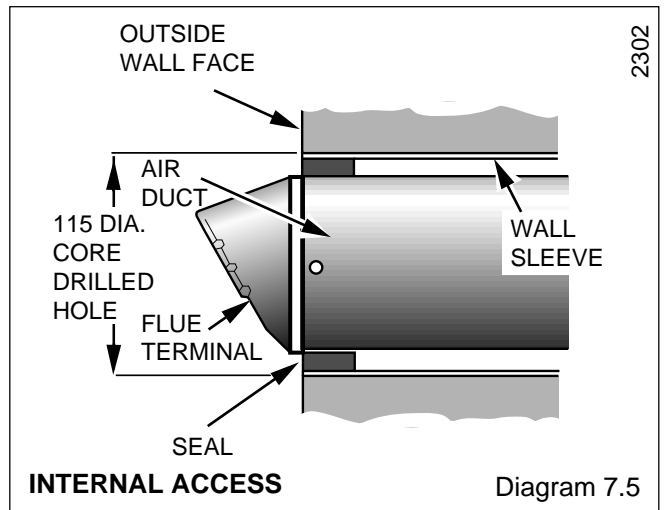
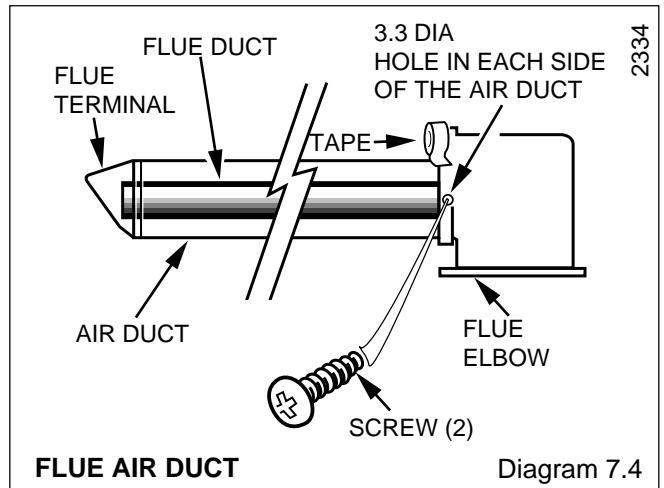

8 Gas and Water Connections

8.1 Gas Connection

Provision is made for the gas supply to be connected from below or through the wall at the rear of the boiler, see diagram 8.1 for position.

Refer also to "Gas Supply", Section 1.7.

Make the gas supply connection to the gas service cock. Slacken or remove the clip, as preferred, while making the connection. Do not subject the gas service cock to heat as you may damage the seals.

8.2 Water Connections

Provision is made for the domestic cold water inlet to be connected from below or through an internal wall at the rear of the boiler, see diagram 8.1 for position. Refer also to Section 5 "Domestic Hot Water System".

Provision is made for the domestic hot outlet, heating flow and return to be connected from below, through an internal wall at the rear of the boiler or from above, passing down either side of the boiler, see diagram 8.2 for clearances. Take care that any pipework connected from above, within the boiler mounting frame will clear the expansion vessels.

If necessary, temporarily fit the boiler, refer to Section 10.1, "Mounting the Boiler".

Flush out the domestic water and heating system before connecting the boiler.

Make the connections to the domestic hot water outlet and the heating system by means of the isolating valves, see diagram 8.1.

Slacken or remove the clips, as preferred, while making the connections. Do not subject any of the isolating valves to heat as you may damage the seals.

Make sure that the drain points on the isolating valves are positioned towards the front of the boiler, also that the drain and operating screw heads are accessible.

8.3 Safety Valve Discharge

WARNING. It must not discharge above an entrance or window or any type of public access area.

A short discharge pipe is supplied loose with the boiler, which when fitted to the safety valve, will end below the boiler at the mark between the cold water inlet and the heating flow, for position and dimension see diagram 8.1.

This must be extended, using not less than 15mm od pipe, to discharge, in a visible position, outside the building, facing downwards, preferably over a drain. The pipe must have a continuous fall and be routed to a position so that any discharge of water, possibly boiling, or steam cannot create any danger to persons, damage to property or external electrical components and wiring.

Note. To ease future servicing it is advisable to use a compression type fitting to extend the discharge pipe.

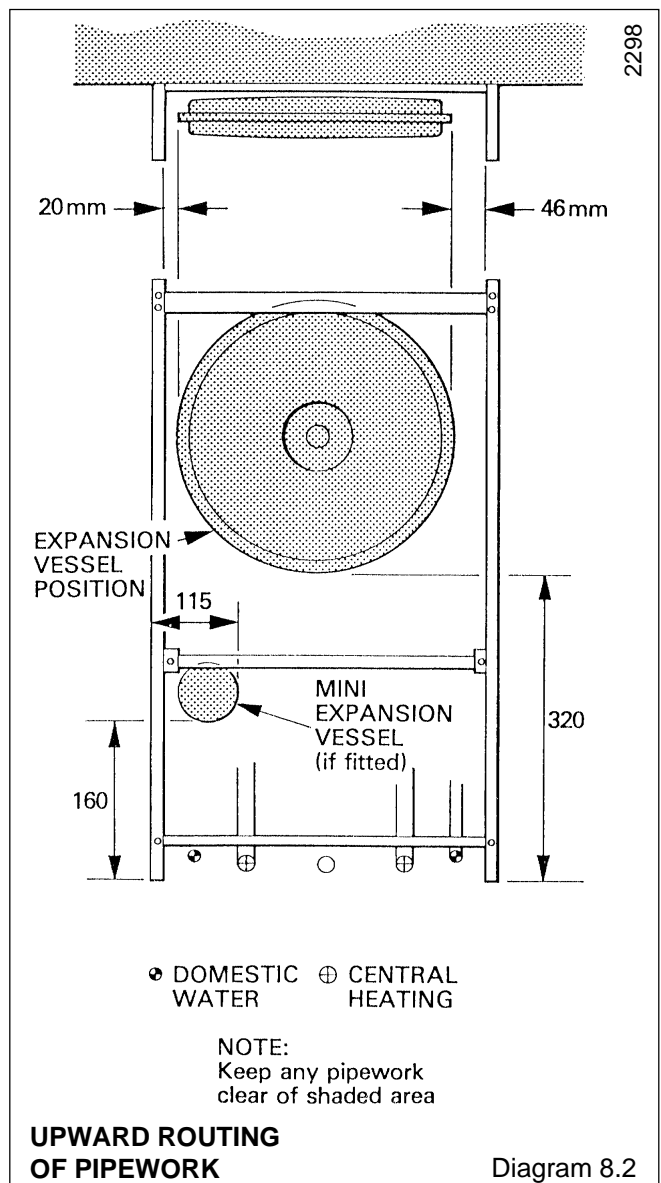
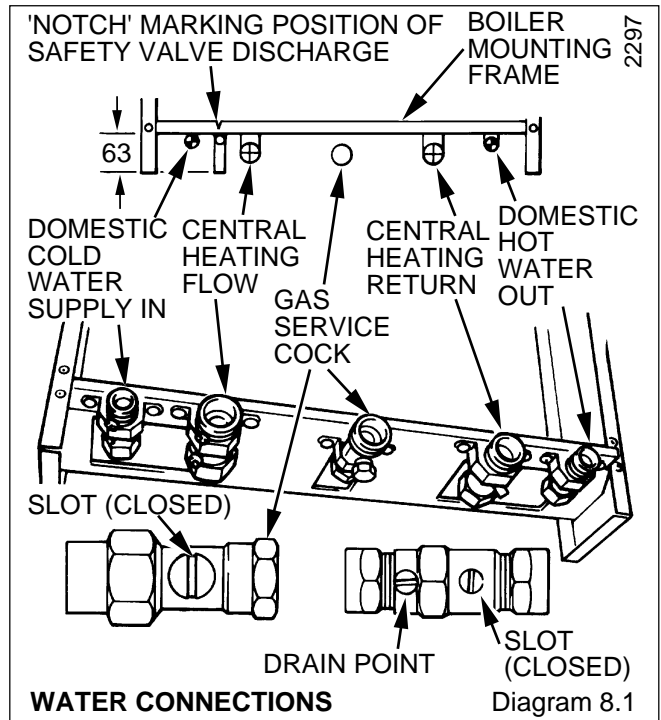

9 Electrical Connections

4323

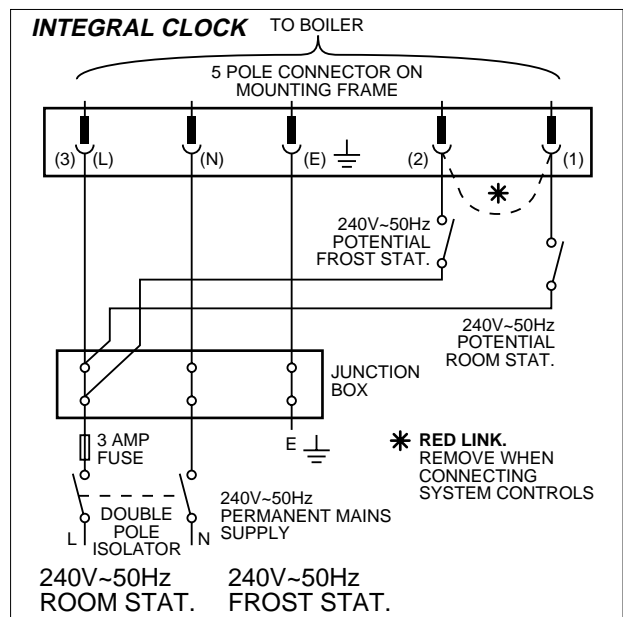
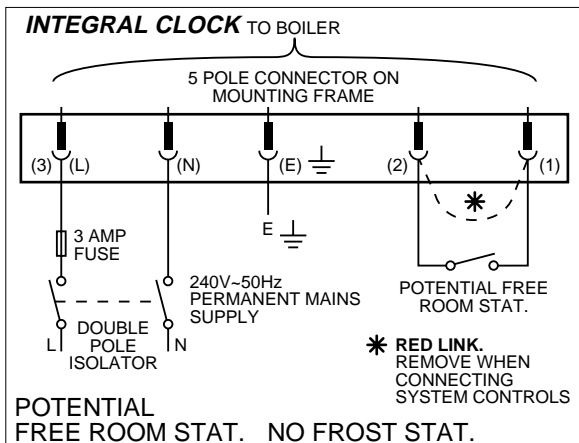
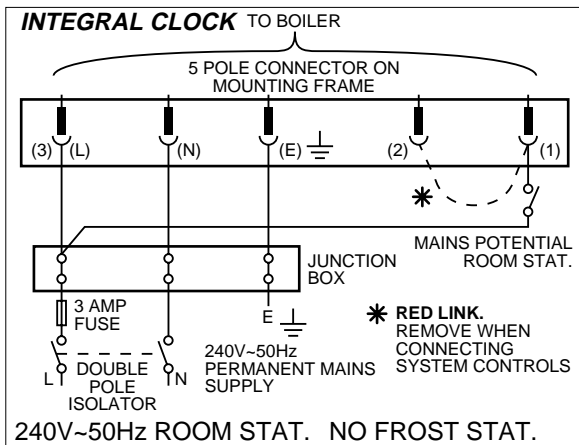
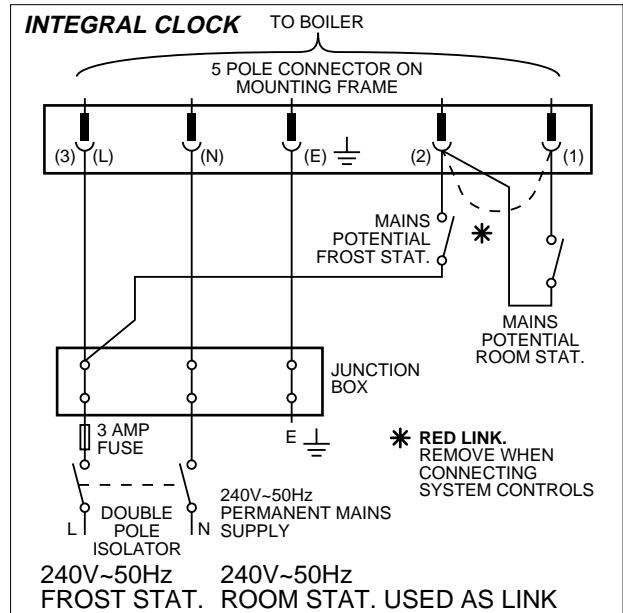
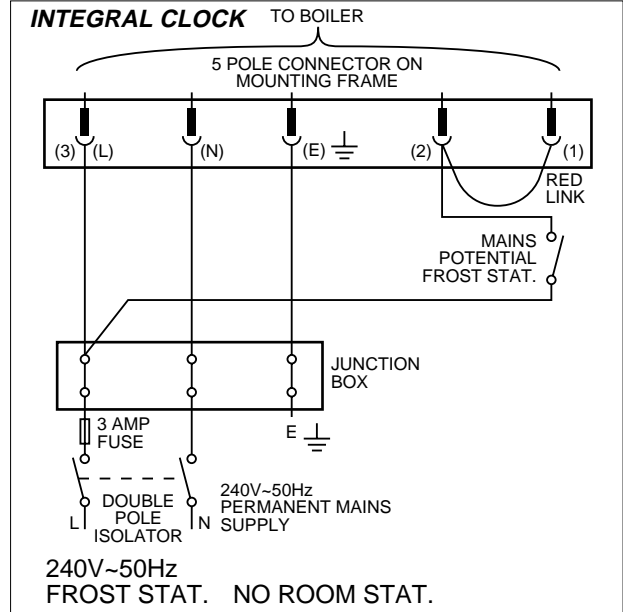
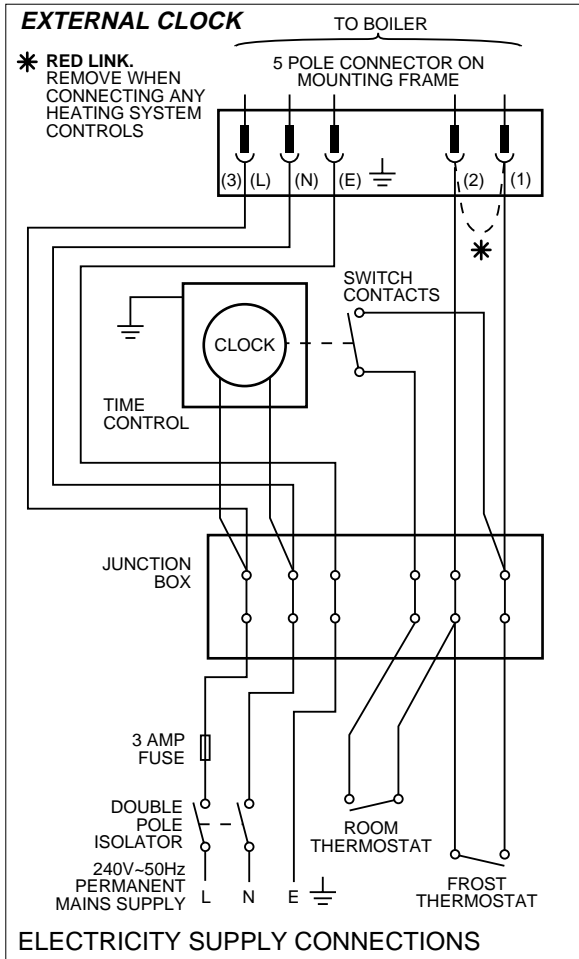

Diagram 9.1

9 Electrical Connections

9.1 Supply Cable Connection

CAUTION: To prevent an induced current from switching the central heating on, when not required, it is important that the heating system control cables are separated from the other mains supply cables.

The boiler requires a permanent mains supply through an external isolator which must also isolate any heating system controls, see diagram 9.1.

Any heating system controls must not interrupt the permanent mains supply to the boiler.

Remove the electrical connector from the loose items pack.

Remove the two screws and cover from the connector, see diagram 9.2.

Using PVC cable of a suitable length and rating as stated in Section 1.8 "Electrical Supply", connect the mains supply cable to the appropriate terminals of the connector, see diagram 9.1.

Standard colours are, Brown - Live, Blue - Neutral, Green and Yellow - Earth.

The mains cable outer insulation must not be cut back external to the plug, see diagram 9.2.

Make the earth cable of a greater length so that if the cable is strained the earth would be the last to become disconnected.

CAUTION: It is ESSENTIAL to make sure that the polarity is correct.

9.2 Heating System Controls

CAUTION: To prevent an induced current from switching the central heating on, when not required, it is important that the heating system control cables are separated from the other mains supply cables.

The heating system should have installed: a programmer and room thermostat controlling the boiler.

Thermostatic radiator valves may be installed in addition to the room thermostat.

Note: For further information, see The Building Regulations 1991 - Conservation of fuel and power, 1995 edition - Appendix G, table 4b.

If electrical controls are not to be used to regulate the heating system, do not disturb the red link cable.

When any form of electrical control is being used to regulate the heating system, remove the red link cable and connect heating system controls in series.

The mains cable outer insulation must not be cut back external to the plug.

9.3 Clock/Timer Kit

An internal clock/timer kit can be supplied, refer to the instructions supplied with it.

9.4 Frost Thermostat

If the installation requires protection by a "frost thermostat", connect a single pole type, to the appropriate terminals of the connector.

9.5 Cable and Connector Securing

After completing all the connections to the boiler, secure the cable(s) with the cover, using the two screws previously removed, see diagram 9.2.

Clip the connector into position with the cable(s) at the back.

Secure all cables in the clamp immediately behind the connector.

If necessary also secure cables to the wall, using suitable cable clips.

Keep all cables away from hot surfaces.

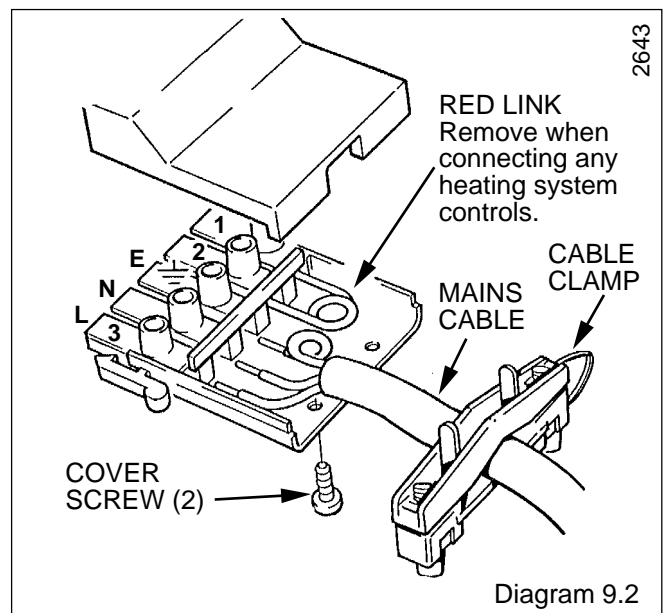

1 0 Boiler Fixing

10.1 Mounting the Boiler

After installing the boiler mounting frame, domestic and heating water systems, making the electrical connections and preparing the flue components, continue as below:

Lift the boiler into position, hooking it onto the boiler mounting frame at the top, then loosely fit the two boiler securing screws at the top, see diagram 6.3.

10.2 Gas and Water Connections

Locate the boiler water pipes into the isolation valves and the gas service cock union halves. Fully push the boiler back to the mounting frame, locating the studs into the clips.

Make the compression joint on the isolating valves and join the gas service cock union. Secure all of the valves and gas service cock with the clips.

10.3 Boiler Securing

Secure the boiler by tightening the two boiler securing screws at the top.

10.4 Discharge Pipe

Remove the two control housing screws, see diagram 10.1.

Remove the control housing and support it on a surface or by screwing it to the front edge of the base, using one of the securing screws, see diagram 10.1.

Fit the short discharge pipe to the safety valve using the nut and olive supplied loose, see diagram 10.2.

Extend the discharge pipe, using only a compression type fitting to join the discharge extension, refer also to Section 8.3 "Safety Valve Discharge".

10.5 Clock/timer (if applicable)

Fit the clock/timer kit following the appropriate sections of the instructions supplied with it.

10.6 Electrical Connector

Connect the two halves of the electrical connector together.

Clip the connector into position on the boiler mounting frame. Secure the cables with cable clamp immediately behind the connector.

Carryout preliminary electrical system checks as below:

1. Test insulation resistance to earth of mains cables.
2. Test earth continuity and short circuit of all cables
3. Test the polarity of the mains.

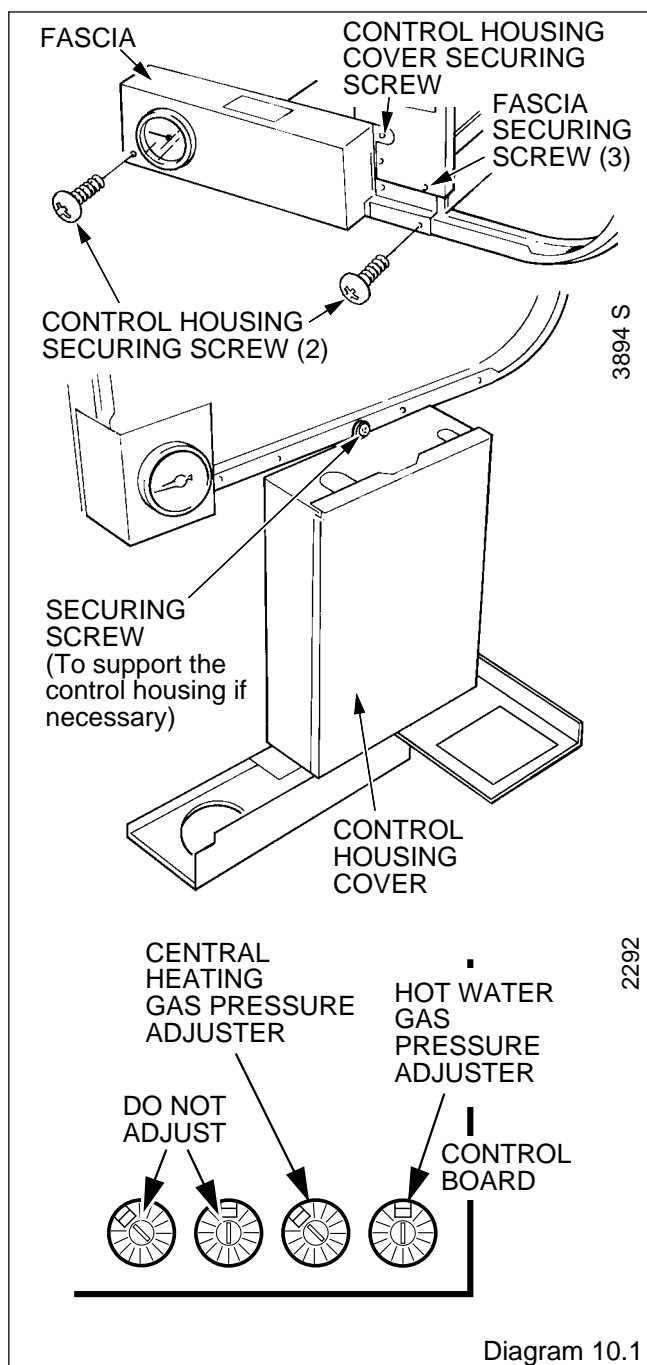

Diagram 10.1

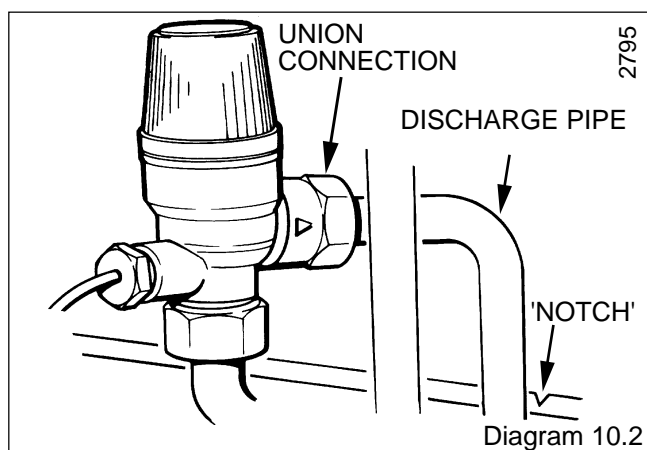

Diagram 10.2

10.7 Flue Fixing

Fit the self-adhesive gasket, supplied in the loose items pack, to the flue elbow, see diagram 10.3.

Pass the prepared ductings through the wall, the longest protrusion of the flue terminal is positioned at the top. If this is impractical to gain access to the outside wall face, the wall sleeve and self adhesive seal must be fitted as described in Section 7.6 "Internal Access".

Fit the flue elbow to the top of the boiler, see diagram 10.3, using the four screws supplied loose. To assist with the location of the flue elbow into the fan outlet, loosen the two wing nuts on the flue collector angle and the two fan securing screws.

Tighten the four screws of the flue elbow evenly to ensure a good seal at the gasket. Tighten the wing nuts and screws, if slackened, to secure the flue collector and fan.

Make the walls good internally and externally around the air duct, also making it weatherproof on the outer wall, from outside, if practicable or by using the wall sleeve and self-adhesive seal as described in Section 7.5 "Internal Access". Make sure that the ductings do not slope down towards the boiler.

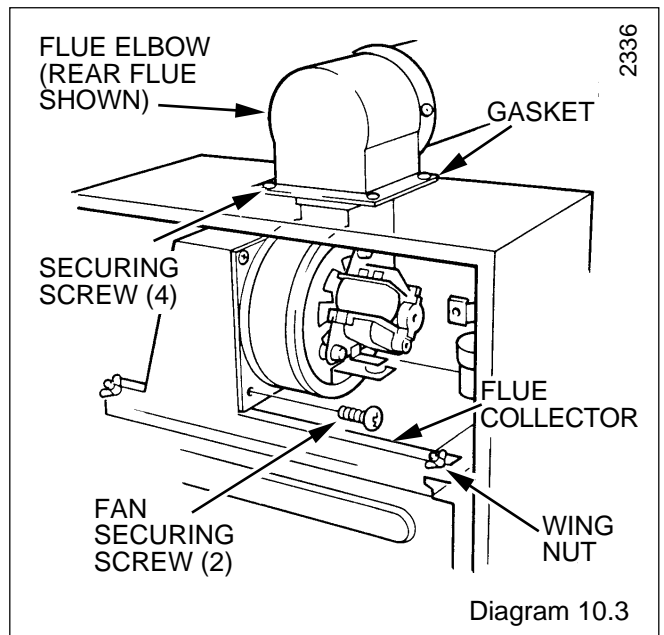

11 Commissioning

11.1 Filling Domestic Water Circuit

Check that the boiler is isolated from the electrical supply, at the external isolator.

Fully open the domestic water supply stop cock or valve in the supply to the boiler.

Open the two domestic water isolation valves, slots in line with the length of the valve, see diagram 8.1.

Open all hot water draw-off taps and close them when water flows. Check for water soundness of the whole domestic water system and boiler.

11.2 Filling the Heating System

It is essential that a bypass is fitted in all installations, 22mm o.d. minimum. The bypass must have a lockable valves "B" in diagram 4.2, incorporated in a position so that inadvertent closure or unauthorised interference is not possible.

The bypass **MUST** be fitted before any system control. A radiator bypass is not recommended.

Open the two central heating isolating valves, slots in line with the length of the valve, see diagram 8.1.

Flush, fill and vent the system refer to Section 4.9 "Filling Sealed Systems".

WARNING. SEVERAL COMPONENTS OPERATE ON MAINS VOLTAGE AND WITH THE OUTER CASE REMOVED, LIVE COMPONENTS BECOME EXPOSED.

To assist in filling and venting, the pump may be operated: Connect the electrical supply, set switch "C" to "On", white flash showing, any remote heating systems controls, time switch and/or room thermostat to call for heat, see diagram 11.1.

Note. If the clock/timer is fitted into the boiler, refer to the setting instructions in the Instructions for Use.

Make sure that the automatic air vent is operating correctly, see diagram 11.2.

Take care not to splash any of the electrical components.

Alternate the position of switch "C" between "On" and "Off" positions to ensure that water flows through all parts of the boiler and air is not trapped in the boiler internal bypass.

Pressurise the system until the pressure is 1.5bar (21.5lb/in²). Check the heating system and boiler for water soundness.

Check the operation of the safety valve by turning the safety valve knob in the direction of the arrow.

Lower the pressure to the initial cold fill design pressure, refer to Section 1.6 "Data". Position the set pointer on the boiler pressure gauge at this pressure also.

11.3 Preparation for Lighting

Isolate the boiler from the mains electrical supply at the external isolator.

Test for soundness and purge air from the gas supply. Turn on the gas service cock, slot in line with the length of the cock.

SIT only - Slacken the two piezo unit bracket screws and remove the bracket, keyhole slot.

Slacken the burner pressure test point screw and connect a suitable pressure gauge, see diagram 11.3.

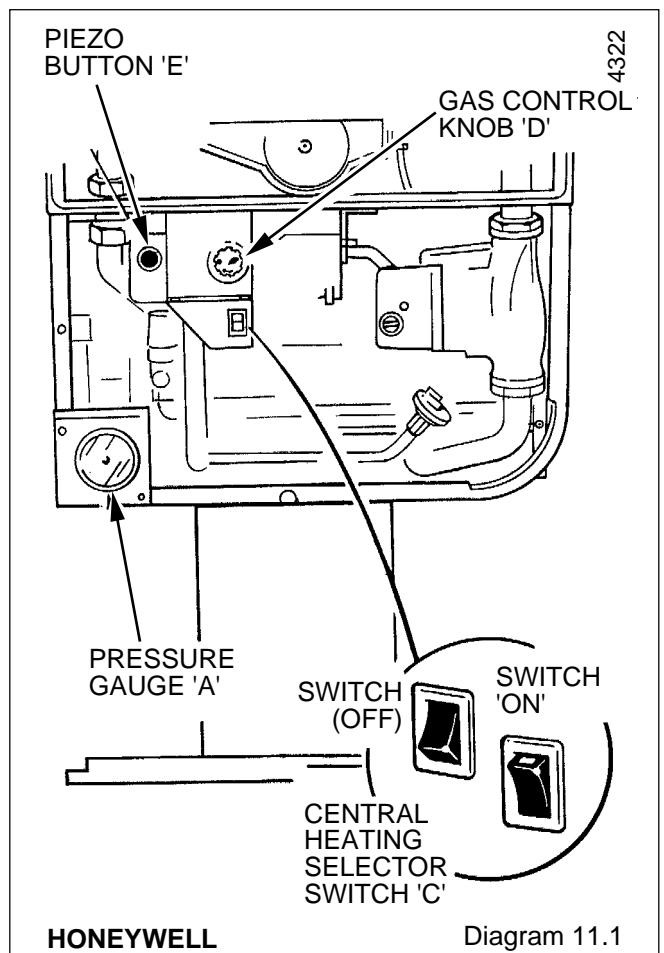
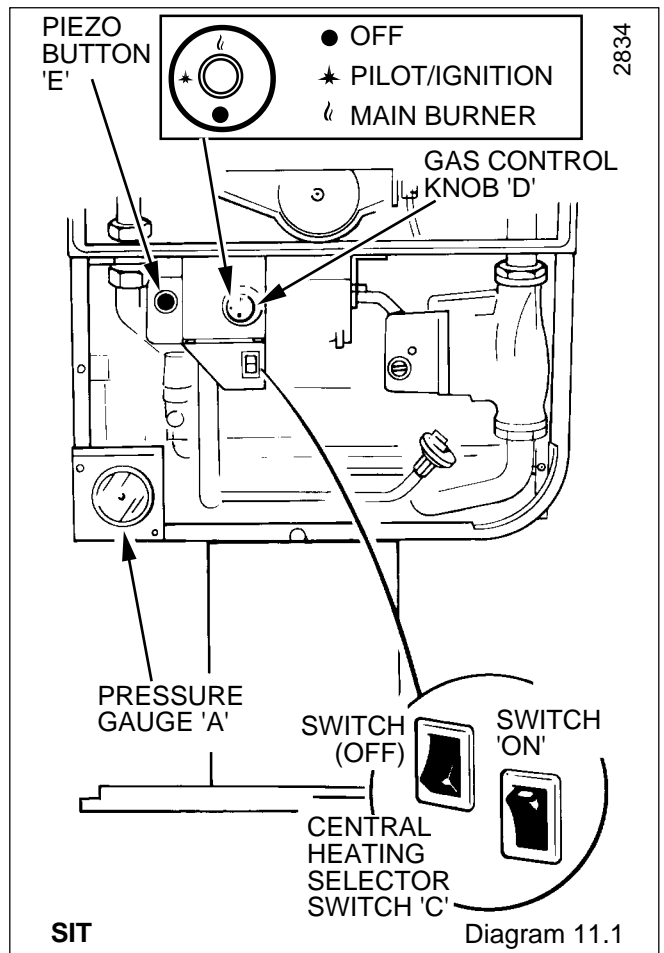

11 Commissioning

11.4 Initial Lighting of Pilot - Honeywell

Identify the boiler controls, see diagram 11.1.

Check that the boiler is isolated from the electrical supply at the external isolator.

Fully depress and hold in gas control knob "D". Press and release piezo button "E" until the pilot burner lights, (at this stage, air may be present in the gas components of the boiler, therefore this operation may need to be repeated). When the pilot flame has lit and is stable, keep knob "D" fully depressed for 15 seconds, then release. The pilot burner should then remain alight.

If the pilot flame goes out now or at any time, a safety device prevents immediate relighting. Wait four minutes before attempting to relight.

If the pilot burner goes out on releasing knob "D", repeat the above lighting sequence but this time keep knob "D" depressed for a little longer.

The pilot flame size is preset and should envelop the thermocouple, the approximate flame size is shown in diagram 11.4. If the flame size is incorrect refer to the adjusting instructions in "Pilot Burner" in "Replacement of Parts" section of the Servicing Instructions.

Check for gas soundness of the pilot supply using leak detection fluid. Take care not to splash any of the electrical components.

Test the operation of the thermocouple flame failure system to ensure the boiler shuts down within 60 seconds, indicated by a "click" from the gas valve.

If the pilot burner will not stay alight, refer to "Thermocouple and Overheat Cutoff" in "Fault Finding" section of the Servicing Instructions.

Fit the cover of the inner case, making sure that it is fitted and seals correctly, using the four screws previously removed, see diagram 6.2.

Make sure that all hot water draw off taps are closed then set switch "C" to "Off" as shown in diagram 11.1.

With the boiler isolated from the electrical supply the pilot flame may go out. If this should happen, wait 4 minutes then relight the pilot burner following the above lighting instructions but with the electrical supply connected.

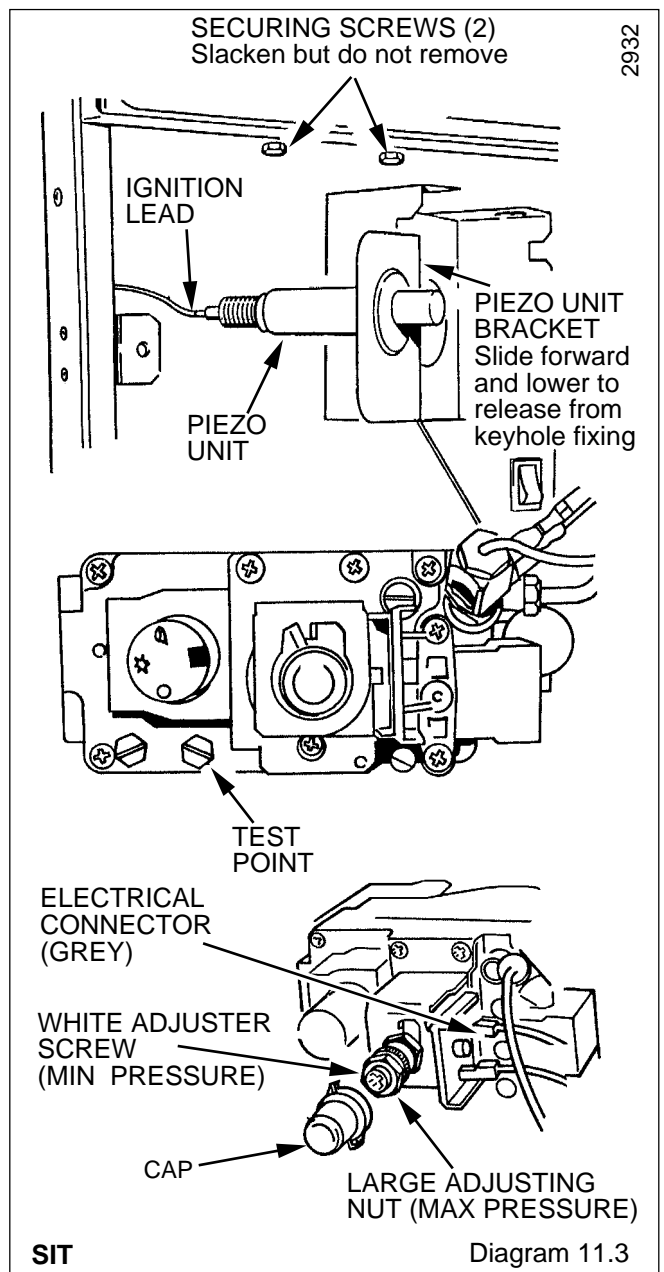
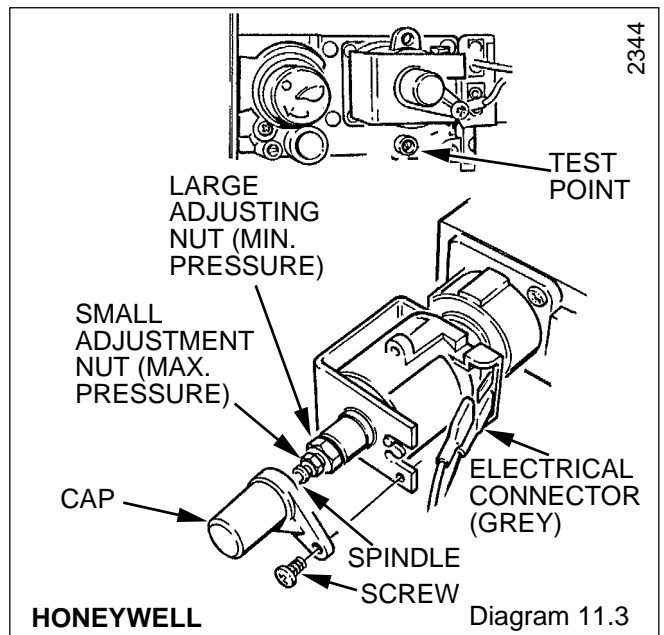
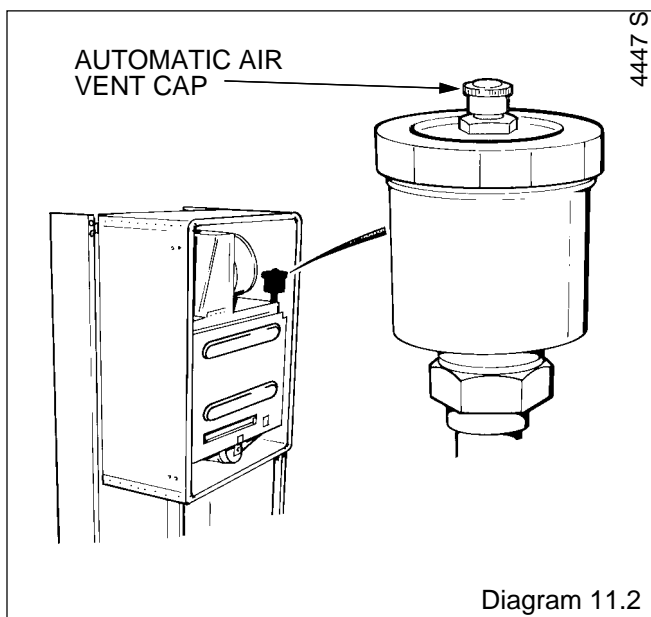

11 Commissioning

11.4 Initial Lighting of Pilot - SIT

Identify the boiler controls, see diagram 11.1.

Check that the boiler is isolated from the electrical supply at the external isolator.

Turn gas control knob "D" to  pilot/ignition position and depress. Press and release piezo button "E" until the pilot burner lights, at this stage air may be present in the gas components, so the operation may need repeating. When the pilot flame has lit and is stable, keep knob "D" fully depressed for about 15 seconds and then release. The pilot burner should stay alight.

If the pilot flame goes out now or at any time, a safety device prevents immediate relighting. Wait four minutes before attempting to relight.

If the pilot goes out on releasing knob "D" repeat the lighting instructions but now keep knob "D" depressed for a little longer after the pilot has lit.

If the pilot burner will not stay alight, refer to "Thermocouple and Overheat Cutoff" in Fault Finding section of the Servicing Instructions.

The pilot flame size is factory preset and should envelop the thermocouple to about the size given in diagram 11.4. If the flame size is incorrect, refer to "Pilot Burner" in Servicing Instructions.

Check for soundness of the pilot supply using a suitable leak detection fluid.

Test the operation of the flame supervision system by turning knob "D" clockwise to "O" position to make sure that it shuts down within 60 seconds, indicated by a click from the valve.

Fit the cover of the inner case, making sure that it is fitted and seals correctly, using the four screws previously removed, see diagram 6.2.

Make sure that all hot water draw off taps are closed then set switch "C" to "Off" as shown in diagram 11.1.

With the boiler isolated from the electrical supply the pilot flame may go out. If this should happen, wait 4 minutes then relight the pilot burner following the above lighting instructions but with the electrical supply connected.

11.5 Burner Pressure - Hot Water - Honeywell

The burner pressure is factory preset and no adjustment should be required.

Connect the electrical supply; the pump and fan will operate for about 30 seconds, then the fan will reduce speed and the pump stop.

Relight the pilot burner.

Fully open the largest hot water draw off tap whereby the main burner will light, the flames gradually increasing to the maximum.

Check the soundness of the boiler gas joints, with the main burner on, using a leak detection fluid. Take care not to splash any of the electrical components.

Fully open the hot water throttle, (clockwise), see diagram 11.5. Check that the water flow rate is not less than 9 Litre/min. (2.0gall/min) to prevent any modulation of the gas pressure. This is equivalent to 6.7 seconds to fill a 1Litre container (3.8 seconds for 1pint).

To achieve this flow rate a water pressure of at least 0.8bar is required during commissioning, although subsequently the appliance will work at a minimum pressure of 0.5bar.

This flow rate should prevent any modulation of the gas pressure.

Check the burner pressure is within +/-0.35mbar (+/-0.14in wg).

of 15.7mbar (6.3in wg), the hot water burner pressure. If this is incorrect, the burner pressure may be adjusted to the correct setting by turning the hot water gas pressure adjuster (potentiometer), using an insulated screwdriver, see diagram 11.6. Gain access to the adjusters on the control board by removing the control housing cover, see diagram 10.1. Turn the adjuster slowly, always making adjustment by reducing below the required pressure then increasing up to the required setting, (turn clockwise to increase).

Close the hot water draw off.

If the maximum pressure cannot be obtained, check that the gas supply of adequate size, refer to Section 1.7.

11.5 Burner Pressure - Hot Water - SIT

The burner pressure is factory preset and no adjustment should be required.

Connect the electrical supply.

Relight the pilot.

Turn gas control knob "D" to '  ', main burner position.

Fully open the largest hot water draw off tap whereby the main burner will light, the flames gradually increasing to the maximum.

Check the soundness of the boiler gas joints, with the burner lit, using a suitable leak detection fluid. Take care not to splash any of the electrical components.

Fully open the hot water throttle, (clockwise), see diagram 11.5. Check that the water flow rate is not less than 9Litre/min (2.0gall/min) to prevent any modulation of the gas pressure. This is equivalent to 6.7 seconds to fill a 1Litre container (3.8 seconds for 1pint).

To achieve this flow rate a water pressure of at least 0.8bar is required during commissioning, although subsequently the appliance will work at a minimum pressure of 0.5bar.

This flow rate should prevent any modulation of the gas pressure.

Check that the burner pressure is 16.1mbar +/- 0.35mbar (6.5in wg +/- 0.14wg) If this is incorrect, the burner pressure may be adjusted by turning the larger brass adjusting nut of the modulator, anti-clockwise to decrease, after removing the cap, see diagram 11.2.

Fine adjustment may be achieved by turning the hot water gas pressure adjuster (potentiometer), using an insulated screwdriver. Gain access to the adjusters on the control board by removing the control housing, see diagram 10.1.

Turn the adjuster slowly, always making adjustments by reducing below the required pressure then increasing up to the required setting, turn clockwise to increase.

Close the hot water draw off.

If the maximum pressure cannot be obtained, check that the gas supply is of adequate size, refer to Section 1.7.

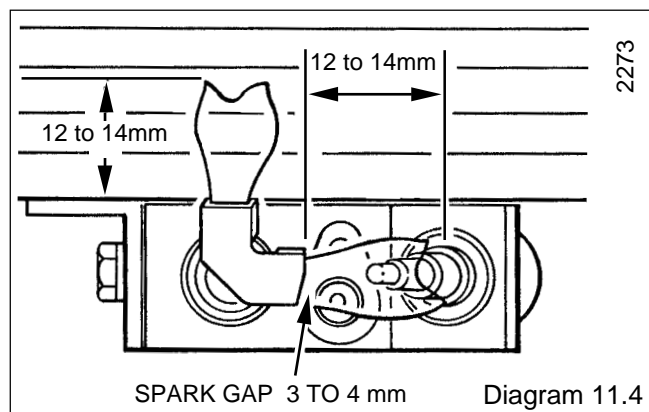

11 Commissioning

11.6 Gas Rate Modulation - Honeywell

The minimum gas rate is factory preset and no adjustment should be required.

ALWAYS CHECK HOT WATER BURNER PRESSURE FIRST - REFER TO SECTION 11.5.

To check the minimum gas rate, first make sure that the boiler is isolated from the electrical supply at the external isolator. Disconnect one of the electrical connectors (grey), from the modulator, see diagram 11.3.

Insulate the connector to make sure that it does not contact any metallic part of the boiler.

Switch on the electrical supply.

Fully open a hot water draw off tap and the main burner will light at the minimum gas rate.

Check that the burner pressure is 2.5mbar +/-0.2mbar, (1.0in wg +/-0.1in wg). If this is incorrect, it may be adjusted by removing the cap and turning the larger adjusting nut of the modulator, (anti-clockwise to decrease the pressure).

If the above adjustment was necessary, it will be essential to check that the maximum pressure can still be obtained. Push the spindle gently in to the stop and hold it in. The maximum pressure should not be less than 16.1mbar, (6.5in wg). If this pressure cannot be achieved, obtain it by turning the small adjusting nut, (clockwise to increase the pressure). Always adjust the minimum pressure first.

If the maximum pressure is unattainable, check that the gas supply is of adequate size, refer to Section 1.7 "Gas Supply". Put right as necessary.

Isolate the boiler from the electrical supply then reconnect the modulator cable and refit the cap.

11.6 Gas Rate Modulation - SIT

The minimum gas rate is factory preset and no adjustment should be required.

Always check hot water burner pressure first - refer to Section 11.5.

To check the minimum gas rate, first make sure that the boiler is isolated from the electrical supply at the external isolator. Disconnect one of the electrical connectors, grey, from the modulator, see diagram 11.3.

Insulate the connector to make sure it does not contact any metallic parts.

Switch on the electrical supply.

Fully open a hot water draw off tap and the main burner will light at the minimum gas rate.

Check that the burner pressure is 2.5mbar +/- 0.2mbar (1.0in wg +/-0.1in wg). If this is incorrect, it may be adjusted by turning the centre white adjuster screw of the modulator, anti-clockwise to decrease, whilst at the same time stopping the larger brass nut from turning, see diagram 11.3.

Isolate the boiler from the electrical supply then reconnect the modulator cable and refit the cap.

11.7 Domestic Water Flow Rate

Adjust the water throttle to obtain a flow rate of 9.0Litre/min (2.0gall/min), (clockwise to increase), see diagram 11.5. This is equal to 7 seconds to fill a 1Litre container (4seconds to fill a 1pint container). Close the tap when adjustment is satisfactory.

The minimum water flow rate is 3.6Litre/min (0.8gal/min)

equivalent to 16.5 seconds to fill a 1Litre container (9.5 seconds to fill a 1pint container). If this flow rate cannot be achieved, check that there is no partial blockage and that the supply is of adequate size. Put right as necessary.

Close the hot water draw off tap.

11.8 Burner Pressure - Heating

The burner pressure is factory preset and no adjustment should be required.

Check that all remote heating system controls, room thermostats, integral clock and the like are switched on/programmed and calling for heat.

Set switch "C" to "On" as shown in diagram 11.1.

The pump will circulate water through the boiler and the main burner will light.

Check that the burner pressure, with the heating system cold to prevent any modulation of the gas pressure, is within +/-0.2mbar (+/-0.08in wg) of 8.2mbar (3.4in wg), Sit and 9mbar (3.4in wg), Honeywell, the central heating pressure.

If the burner pressure is incorrect, it may be adjusted to the correct setting by turning the central heating gas pressure adjuster (potentiometer), using an insulated screwdriver, see diagram 10.1. Turn the adjuster slowly, always making adjustment by reducing below the required pressure then increasing up to the required setting, (turn clockwise to increase).

Isolate the boiler from the electrical supply.

Remove the pressure gauge and tighten the test point screw.

Note. It will be necessary when finally mounting the clock to reposition the gas valve solenoid and thermocouple lead.

Fit the cover and secure the control housing with the screws previously removed.

Test for gas soundness around the burner pressure test point with the main burner alight, using leak detection fluid. Take care not to splash any of electrical components.

SIT only - Refit the piezo bracket.

11.9 Temperature Settings

The domestic hot water outlet and central heating flow temperatures are factory preset and sealed, therefore cannot be adjusted.

The nominal temperature setting for the domestic hot water outlet is 60°C (140°F) at a flow rate of 3.6Litre/min (0.8gall/min).

The nominal maximum flow temperature setting for central heating is 82°C (180°F).

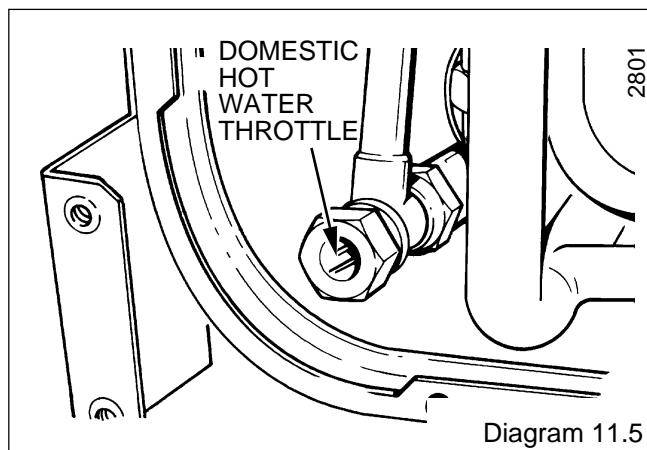

11 Commissioning

11.10 Heating System - Commissioning

Check that all remote controls and integral clock are calling for heat.

Fully open all radiator valves, flow control valve "A" and bypass valve "B", see diagram 4.2.

Set the heating system in operation and balance the radiators.

Adjust the control valve "A" to achieve the required system differential temperature between the flow and return.

Turn off all radiators, then adjust bypass valve "B" to achieve the same temperature difference between the boiler flow and return.

Refer to Section 4.6 and diagram 4.1 and 4.1A.

Allow the system to reach maximum temperature then switch off, isolate the boiler from the electrical supply and drain the system rapidly whilst still hot.

Fill and vent the system as described in Section 11.2 "Filling the Central Heating Circuit". Add inhibitor, if applicable, refer to Section 4.10 "Inhibitor".

Lower the pressure to the initial cold fill design pressure, using the external draining tap, close to the boiler, refer Table 2 and Section 4.11.

Lock or remove the handles from the spindles of flow control valve "A" and bypass valve "B" to prevent unauthorised adjustment.

The permanent mains electrical supply to the boiler must not be switched off whilst the pilot flame is alight.

11.11 Completion

The user control door is designed for left or right hand hinging. If required the hinge can be moved to the other side to that supplied, as follows:

Remove the hinge pin bracket securing screw then remove the hinge pin retaining bracket and holding the door, remove the hinge pin. Prise out the hinge pin bushes and fit on to the opposite side of the door, see diagram 11.6.

Remove the screw and nut and fit to the opposite side of the case. After removing the hinge pin retaining bracket refit the door and hinge pin. Refit the hinge pin retaining bracket and fit the securing screw.

Fit the catch assembly, supplied in the loose items pack, see diagram 11.6.

If required, fit the plastic covers to hide the bracket securing screws.

Change the position of the "Push" label to suit the new door opening.

Clock/timer, if fitted, remove the screws, nuts and washers to release the cover plate, see diagram 11.6.

Stick the casing label to the right hand side of the clock/timer.

Fit the outer case, secure with the four screws, see diagram 11.6.

Note: Secure with the two outer screws only if there is no clock/timer fitted.

Set the boiler and any remote heating control to the desired settings, then close the door.

11.12 Instruct the User

Instruct and demonstrate the lighting procedure, then advise the user of the efficient and safe operation of the boiler.

Instruct and demonstrate the operation of any heating system controls.

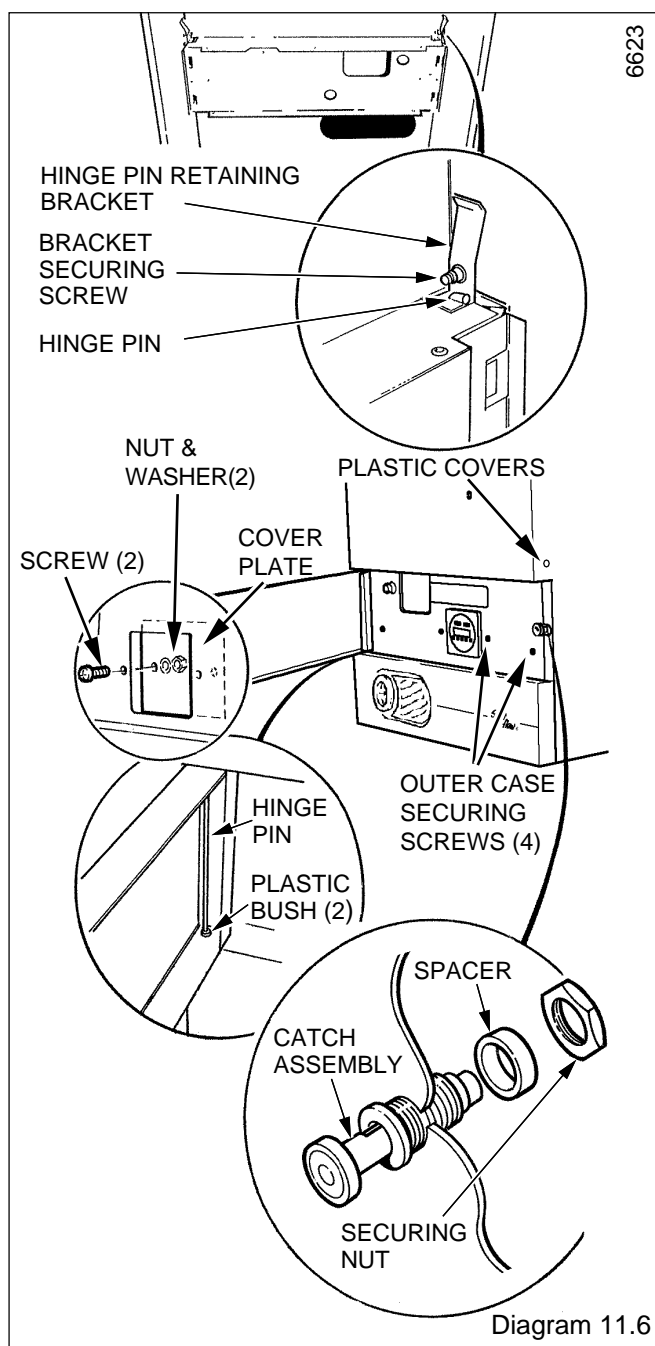

Advise the user on the use and maintenance of any scale reducer and pass on any relevant instructional documents.

Advise the user that to ensure the continued efficient and safe operation of the appliance it is recommended that it is checked and serviced at regular intervals. The frequency of servicing will depend upon the particular installation and usage, but in general once a year should be enough.

Draw attention, if applicable, to the current issue of the Gas Safety (Installation and Use) Regulations, Section 35, which imposes a duty of care on all persons who let out any property containing a gas appliance.

It is the Law that any servicing is carried out by a competent person.

Advise the user of the precautions necessary to prevent damage to the system and building in the event of the heating system being out of use during frost and freezing conditions.

Advise the user that the permanent mains electrical supply must not be switched off whilst the pilot is alight.

Reminder - Leave these instructions with the user.

1 General Data

This boiler will be fitted with either a Honeywell or SIT gas control valve. It can be identified as shown:-

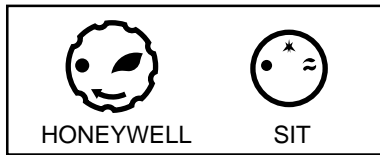

1.1 Servicing or Replacing Parts

To ensure the continued efficient and safe operation of the appliance it is recommended that it is checked and serviced as necessary at regular intervals.

The frequency of the servicing will depend upon the particular installation conditions and usage, but in general once a year should be enough.

The servicing of this boiler must be carried out by a competent person in accordance with the rules in force in the countries of destination.

Unless stated otherwise all parts removed for servicing or replacing are fitted in the reverse order to removal.

After completing any servicing or renewing of any gas carrying part, ALWAYS test for gas soundness and carry out functional checks of controls.

Throw away all used sealing washers, gaskets and "O" rings when renewing parts. Use the new ones supplied with the spares assemblies.

1.2 Data Label

The data label is positioned on the inner case and can be seen when the outer case is removed.

1.3 Isolation of Boiler

Before starting any servicing or the replacement of parts, isolate the boiler from the electrical supply at the external isolator and close the gas service cock, see diagram 1.1.

Before disconnecting any water containing part, close the appropriate isolating valves and release the water pressure before draining the boiler, see diagram 1.1 and refer to Section 1.6 System Pressure.

1.4 Outer Case Removal

The door opens to the left or right hand side.

The door catch is spring loaded, to open, push the side opposite to the hinge, then pull.

Remove the two screws securing the outer case then unhook the case at the top and pull it forwards and off, see diagram 6.1 installation section.

Note: Remove the four securing screws if there is a clock/timer fitted.

1.5 Cover - Inner Case

Remove the cover of the inner case, secured by four screws, see diagram 1.2.

1.6 System Pressure and Draining

All water containing parts of the central heating circuit within the boiler are under the system pressure. Before any parts of this circuit are disconnected, isolate the central heating valves and release the pressure by operating the pressure relief safety valve, see diagram 11.2 installation section.

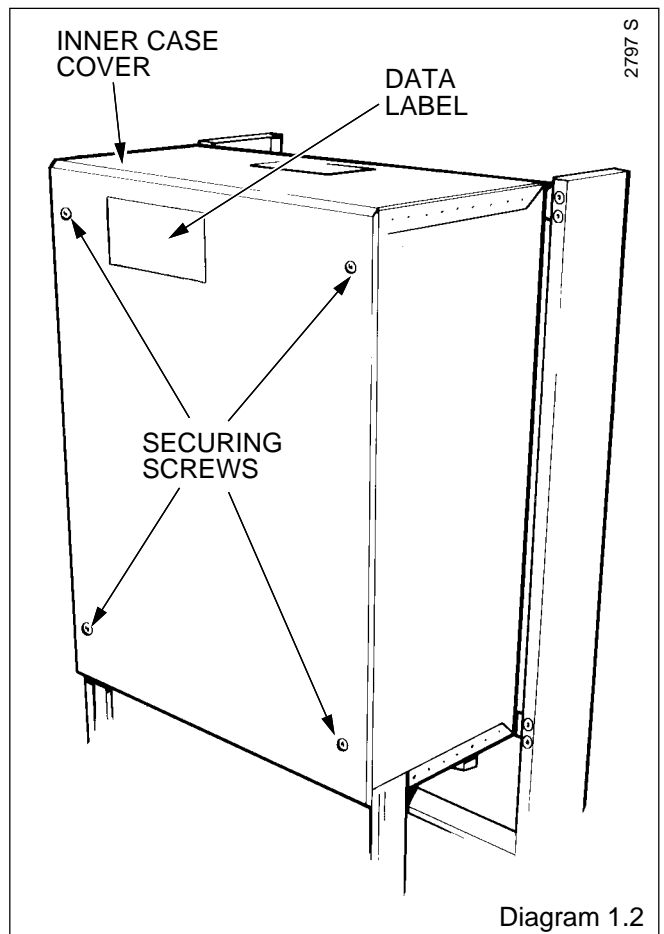
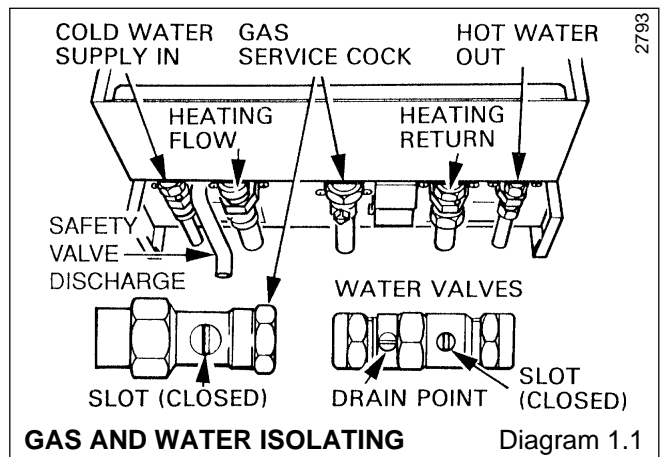

To gain access to the safety valve knob, remove the outer case, refer to Section 1.4. Turn the knob in the direction of the arrow.

Drain the boiler heating circuit at the drain points on the appropriate isolation valves, see diagram 1.1. Make sure that the automatic air vent is working. Remove the cover of the inner case, for access, refer to Section 1.5.

All water containing parts of the domestic hot water circuit of the boiler will be under the supply water pressure. Before any parts of this circuit are disconnected, isolate the domestic water valves, open the hot water taps and drain the boiler at the isolation valves, see diagram 1.1.

After replacing any water containing part of the central heating system, make up the water loss, vent all air and pressurise the system, refer to Commissioning in the Installation Instructions.

Check for water soundness and that the safety valve seats without leaking.

2 Servicing

2.1 Pilot Check

Check if the pilot flame is burning correctly and of the correct size, see diagram 4.4. If the pilot flame is not correct, the pilot injector will require removing when accessible.

2.2 Isolation and Access

Before starting, refer to Section 1.1.

Isolate the boiler from the electrical supply and close the gas service cock, refer to Section 1.3.

Remove the outer case and the cover of the inner case, refer to Sections 1.4 and 1.5.

Remove the fan from the flue collector, refer to Section 4.1

Remove the flue collector, secured with two wing nuts and hook bolts.

Remove the main burner, refer to Section 4.2.

2.3 Cleaning the Heat Exchanger

Place a sheet of paper in the combustion chamber to cover the injector and pilot assembly, to collect any debris.

Brush the heat exchanger.

Remove the paper together with any debris.

Do not use a brush with metal bristles.

2.4 Cleaning the Main Burner

Use a vacuum cleaner or suitable brush to clean the burner thoroughly, making sure that all the burner ports are not obstructed.

Do not use a brush with metal bristles.

2.5 Cleaning the Pilot Injector

If the pilot flame was not burning correctly, it is necessary to remove the pilot injector, refer to Section 4.5.

Inspect the injector and clean if necessary, by blowing clear only.

Do not use a wire or sharp instrument.

2.6 Service Checks

Inspect the pilot burner, spark electrode, adapter olive on the pilot tube and thermocouple. Clean if necessary or renew, refer to Section 4.4, 4.5 and 4.6.

Check the main injector, cleaning or renewing as necessary, refer to Section 4.3.

Before replacing any parts removed during servicing, inspect the condition of all seals and joints, renewing as necessary.

Check the condition of the combustion chamber insulation. If renewing, refer to Section 4.30.

Check the spark gap, upon assembly, see diagram 4.4.

2.7 Initial Assembly

Assemble the following parts only, in the reverse order of removal.

Make sure that the main burner is located on the main injector and is horizontal, the tips of the rearmost blade under the two burner guides.

The combustion chamber front panel should be fitted loosely, then the flue collector also fitted loosely, ensuring that it is seated correctly on the heat exchanger and over the top edge of the front panel.

Fit the fan, locate it into the flue elbow and the clip at the rear, then secure with the two screws.

Connect the electrical cables to the fan, the polarity of the two connectors is not important.

Secure the flue collector and combustion chamber front panel by tightening the wing nuts and screws evenly.

2.8 Operational Checks

Check the safety valve manually by turning the knob in the direction of the arrow.

Light the boiler, carry out operational checks and any necessary adjustments as described in Commissioning in the Installation Instructions.

2.9 Completion

Hook the outer case on the top and secure with the screws previously removed, see diagram 6.1 installation section.

3 Fault Finding

3.1 Initial Checks

If the boiler fails to operate, first check the following and put the problem right, if possible.

Check that the electrical supply is available at the boiler and that the fuses are in order.

Make sure that the system pressure gauge registers 0.7bar minimum and that the automatic air vent works. Refer to Installation Instructions Section 11.2.

The electronic control board of the boiler can be damaged by incorrect testing with the power on.

Check that the gas supply is available at the boiler and purged of air. Is the pilot burner lit?. If the pilot burner will not light, refer to Section 3.2.

If the pilot burner fails to remain alight, refer to Section 3.3.

Check that the boiler is set for the correct mode of operation.

With the central heating selector switch set to "Off", check that the domestic water supply is available and water flows freely from the hot water taps.

With the central heating selector switch set to "On", check that all heating system controls, (if fitted) are working correctly and calling for heat. Isolate the boiler from the electrical supply. Disconnect the rear multi-pole connector at the base of the boiler and release the cable from the clamp. Remove connector cover and test for continuity of the remote heating control circuit at terminals 1 and 2, see diagram 3.1.

If there is continuity at these connections, carry on with the detailed fault finding, refer to Section 3.4. If there is no continuity, a remote heating system fault is indicated, which must be put right.

3.2 Pilot Burner and Ignition System

Symptom. The pilot burner will not light or stay alight. Test the pilot burner and ignition system as described in the fault finding procedure, see diagram 3.2.

3.3 Thermocouple and Overheat Cutoff

On completion of initial checks as described in Section 3.1.

Symptom. The pilot burner fails to stay alight.

Test the thermocouple, overheat cutoff and thermocouple connectors, as described in fault finding diagram 3.3, see also diagram 3.4.

Check the millivoltage of the thermocouple closed circuit at points "A" and "E", see diagram 3.4. This should be within the range of 6 to 11mV.

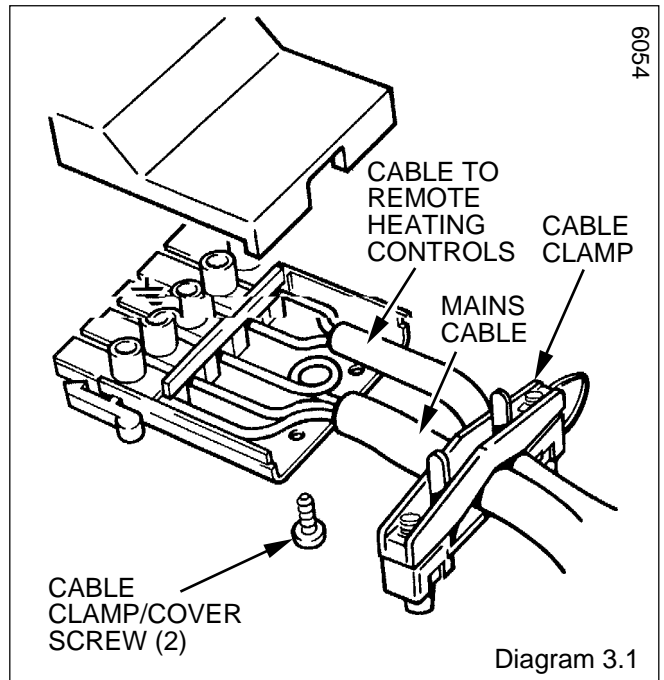

3 Fault Finding

2839A

**PILOT WILL NOT LIGHT
START HERE**

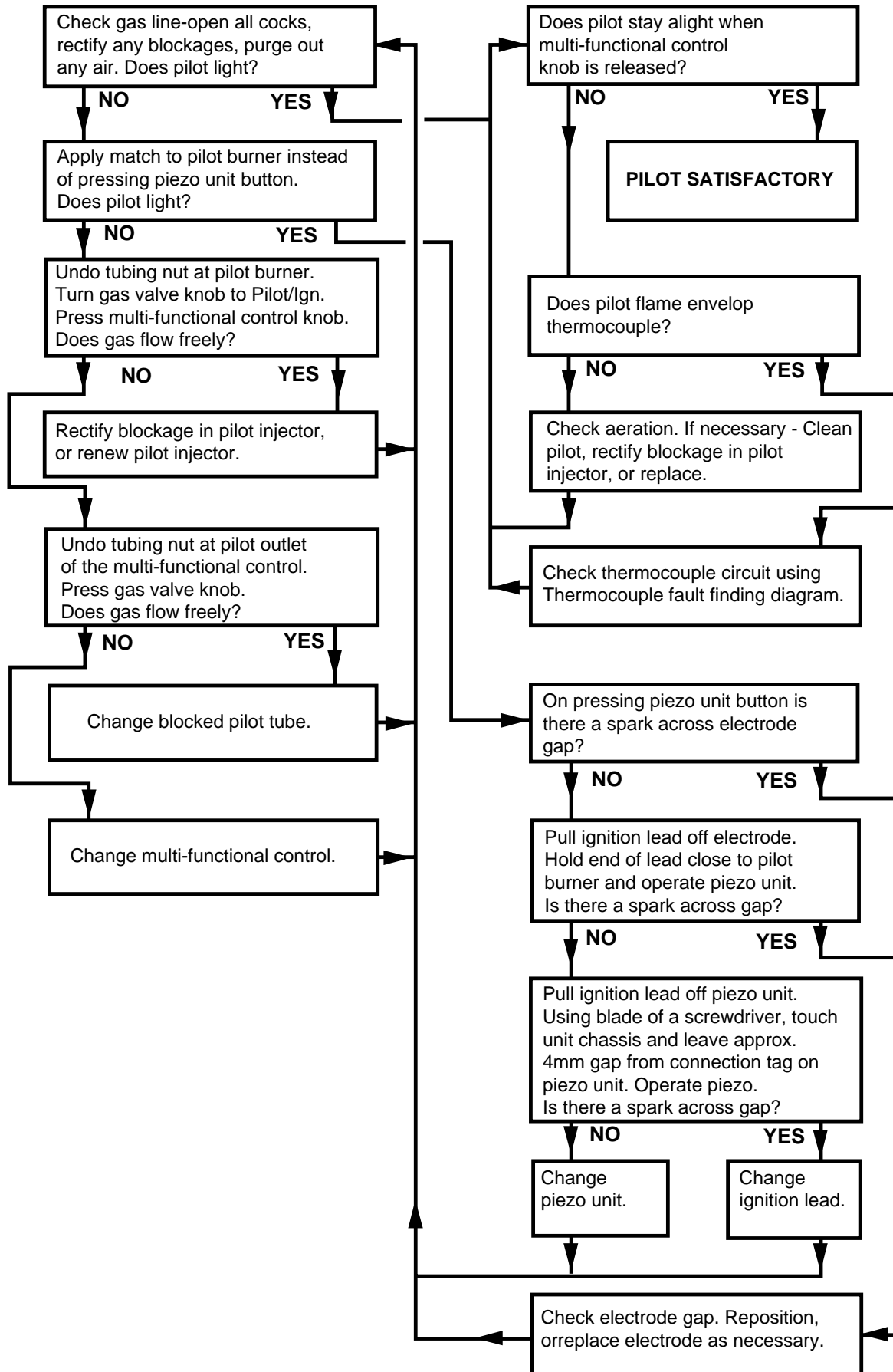

Diagram 3.2

3 Fault Finding

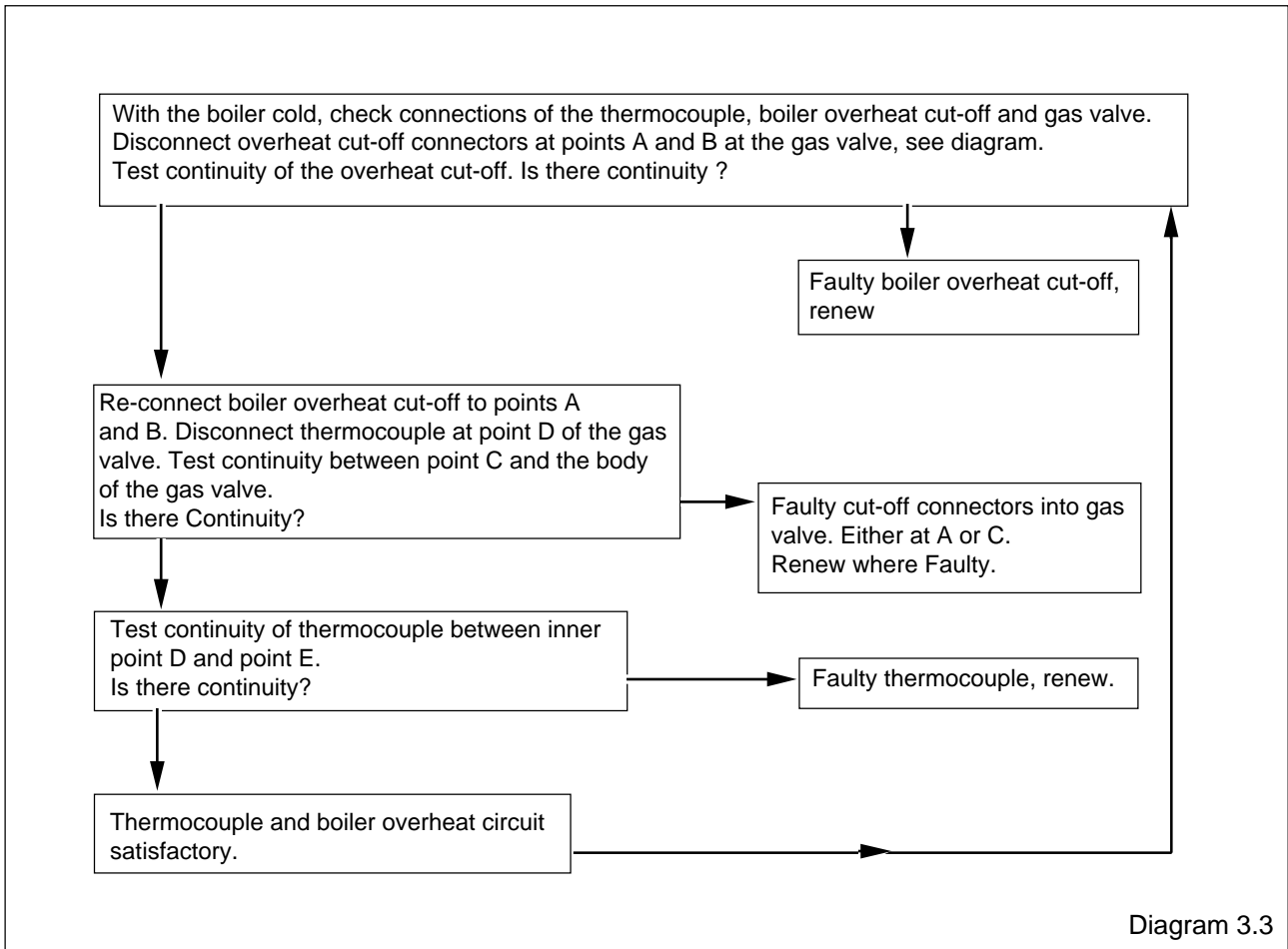
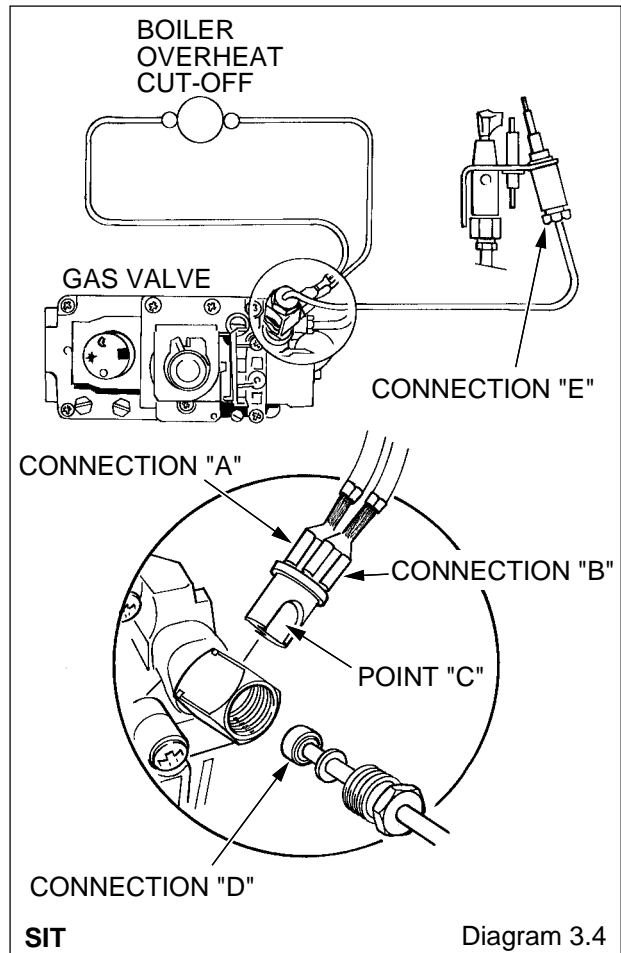
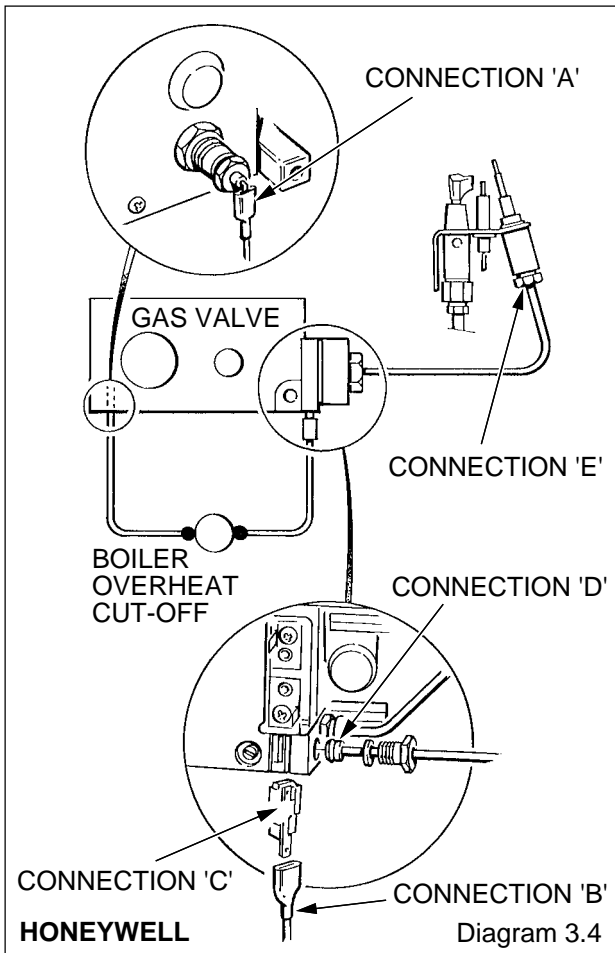

Diagram 3.3



3 Fault Finding

3.4 Clock/Timer

If the clock has failed it can be bypassed by disconnecting the plug at the wall frame. Gain access to the control box, refer to Section 4.12, disconnect the clock wiring harness from the four way terminal block. Fit yellow link between terminals Y1 and Y2.

This is a temporary measure and the clock should be repaired or replaced as soon as possible.

3.5 Electrical

The preliminary electrical system checks, as described in a multimeter test book, are the first checks to be carried out during a fault finding procedure.

On completion of a fault finding task that has required the disconnection and making of electrical connections, then checks for earth continuity, polarity and resistance to earth must be carried out.

Isolate the boiler from the electrical supply, refer to Section 1.3.

Gain access to the boiler controls by removing the outer case, refer to Section 1.4. Check that all cables and connectors are secure.

Gain access to the control board, refer to Section 4.13. Check all cables at the multi-pin connectors on the board.

Test the two fuses on the control board and renew as necessary. Fuse 1 is type T1.6A, fuse 2 type T 630mA. If a fuse repeatedly fails or the initial fault finding checks, described in Section 3.1 indicate a boiler fault, check the boiler electrical circuits and follow the fault finding procedures, see diagram 3.5, 3.6, 3.7 and 3.8, and for clock/timer fault finding diagram 3.9.

KEY	
BROWN.....	br
BLUE.....	b
RED.....	r
PURPLE.....	p
VIOLET.....	v
MAINS FUNCTIONAL FLOW	

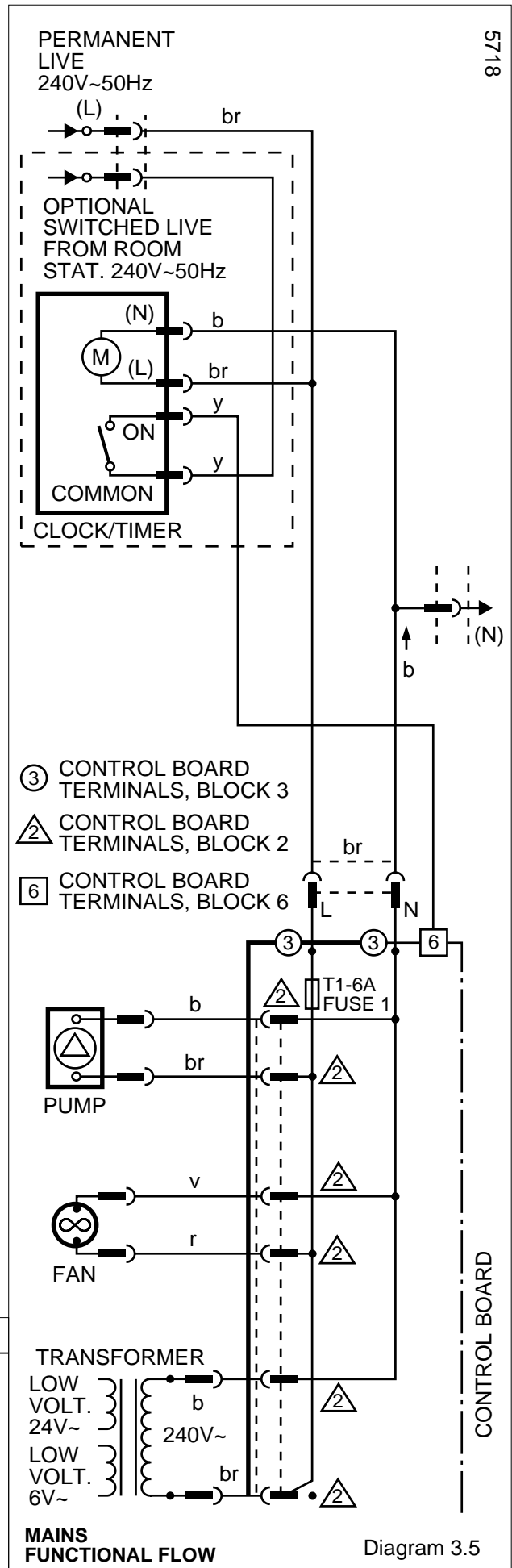

3 Fault Finding

4687

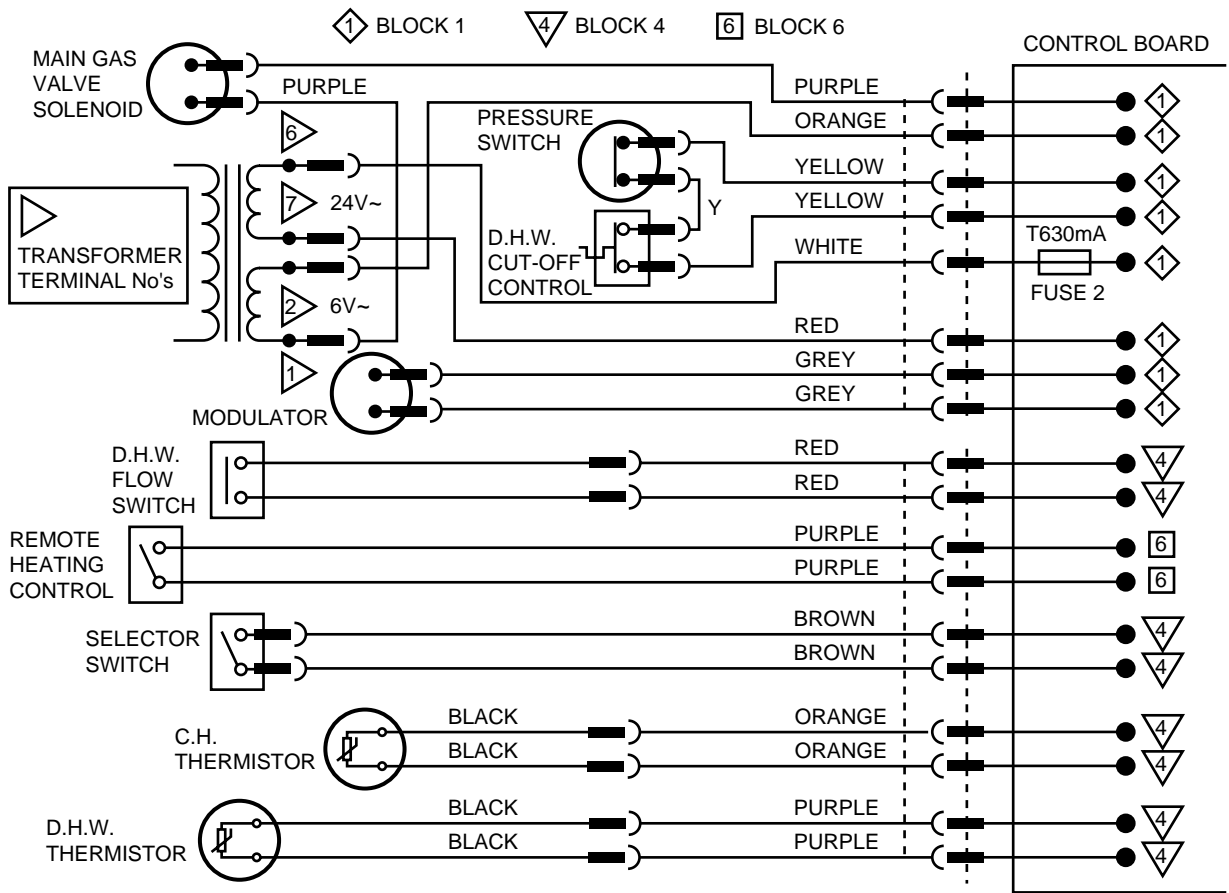

Diagram 3.6

3 Fault Finding

4457 cont.

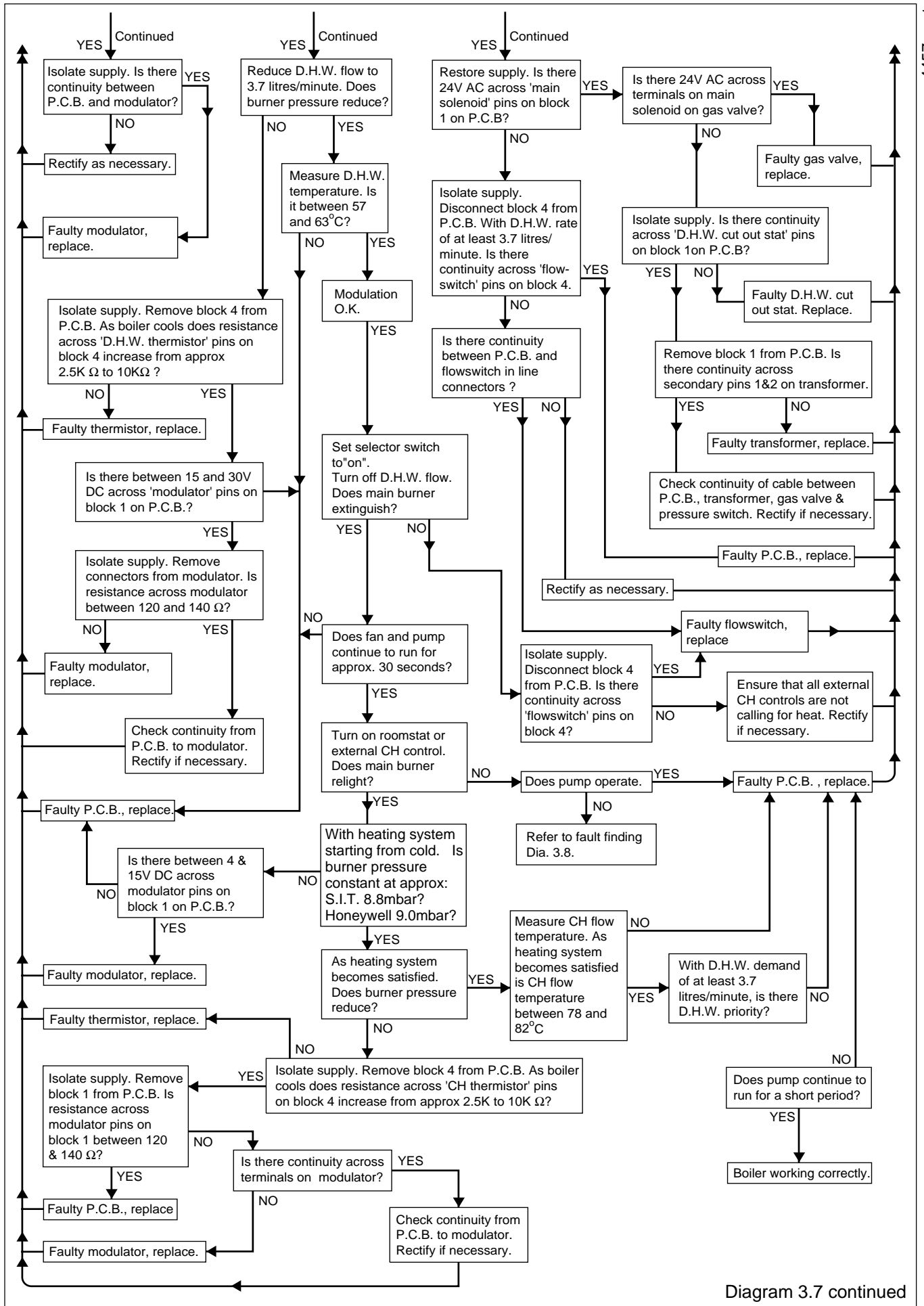

Diagram 3.7 continued

3 Fault Finding

4689

Continued from diagram 3.7

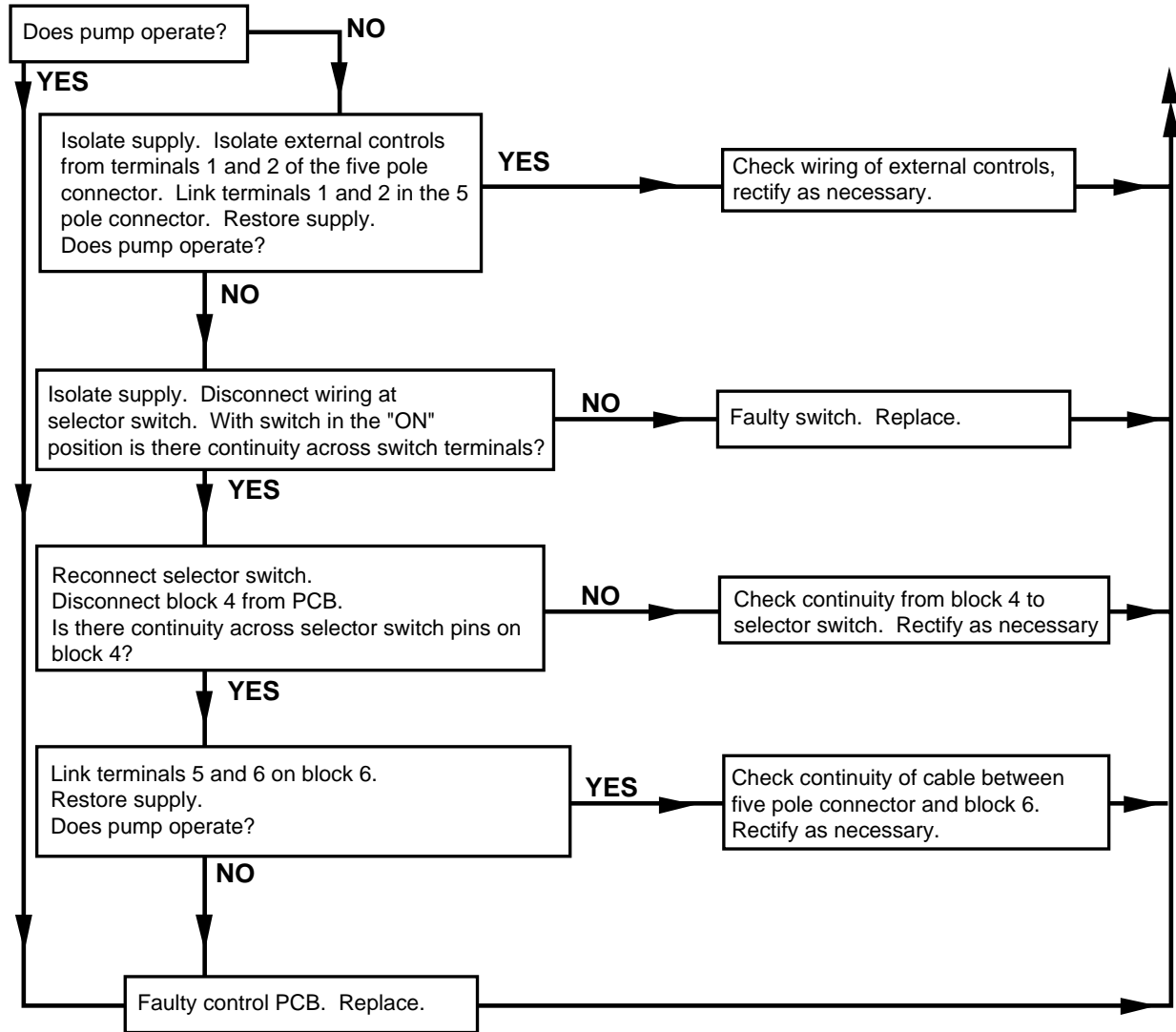
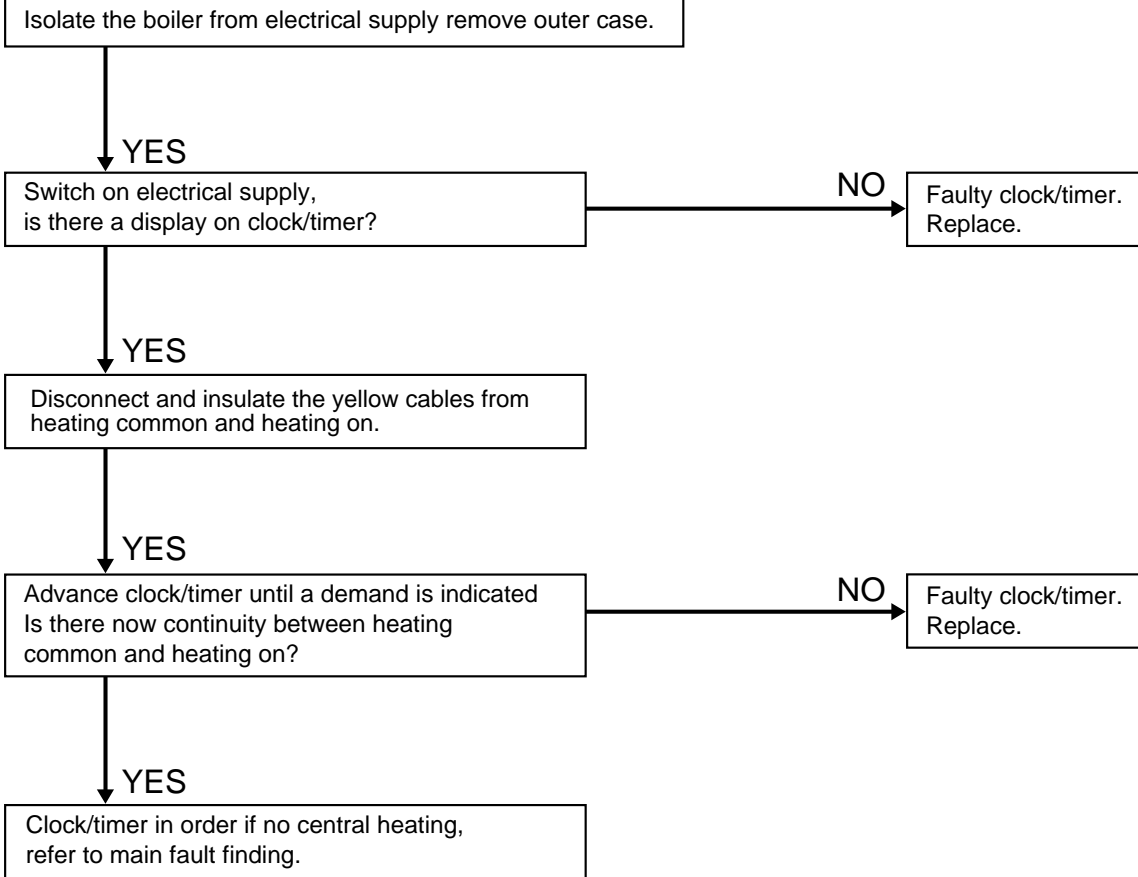

Diagram 3.8

3 Fault Finding

5669

If a mains potential room thermostat is connected, ensure that the switch live is connected to Pin 1 in the 5 pole connector.
Check continuity of clock/timer harness, ensure an electrical supply is available, ensure that remote controls are calling for heat.



DIGITAL CLOCK/TIMER

Diagram 3.9

CLOCK FAULT FINDING

5667

If a mains potential room thermostat is connected, make sure that the switch line is connected to pin 1 in the 5 pole connector.
Check continuity of clock harness, make sure an electrical supply is available make sure that remote controls are calling for heat.

Make sure the override switch if fitted is in the "⊕" position

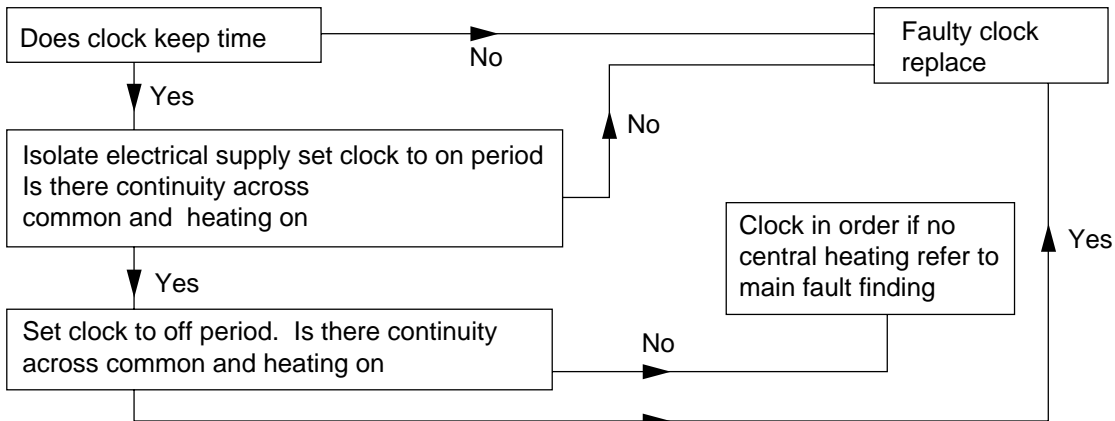

ELECTRO/MECHANICAL FAULT FINDING

Diagram 3.9

4 Replacement of Parts

4.1 Fan

Before starting refer to Section 1.1.

Isolate the boiler from the electrical supply, refer to Section 1.3.

Remove the outer case and the cover of the inner case, refer to Section 1.4 and 1.5.

Disconnect the two electrical connectors at the fan, see diagram 4.1. It is not necessary to disconnect the green and yellow earth cable.

Remove the fan, secured with two screws at the front, also located into the flue elbow and clip at the rear.

To renew the motor and impeller, remove the three screws securing it to the housing.

Transfer the earth cable to the replacement motor terminal marked \oplus , fitting the earth cable and shakeproof washer when securing the fan.

To fit the fan housing, locate it into the flue elbow and the clip at the rear, push fully upward into the flue elbow to ensure a good seal, then secure the fan with the two screws.

Connect the electrical cables, the polarity of the two connectors is not important.

4.2 Main Burner

Before starting refer to Section 1.1

Isolate the boiler from the electrical supply, refer to Section 1.3.

Remove the outer case and the cover of the inner case, refer to Sections 1.4 and 1.5.

Slacken the two wing nuts securing the flue collector, see diagram 4.2.

Remove the combustion chamber front panel, secured with four screws and a wing nut.

Separate the pilot assembly from the main burner secured with two screws and washers, see diagram 4.3.

Remove the main burner from the main injector at the rear. Raise the burner up and forwards, easing the pilot assembly forwards to clear, taking care not to damage the combustion chamber insulation or the pilot burner assembly.

Make sure that the main burner is fitted correctly on assembly, located on the main injector and horizontal, the tips of the rearmost blade under the two burner guides.

Locate the combustion chamber front panel under the front edge of the flue hood on assembly, then secure all screws and wing nuts.

4.3 Main Injector

Before starting refer to Section 1.1.

Isolate the boiler from the electrical supply, refer to Section 1.3.

Remove the outer case and the cover of the inner case, refer to Section 1.4 and 1.5.

Remove the main burner, refer to Section 4.2.

Unscrew the main injector.

Fit the new sealing washer supplied, to ensure gas soundness, when fitting the main injector.

4.4. Pilot Burner

Before starting refer to Section 1.1.

Isolate the boiler from the electrical supply, refer to Section 1.3.

Remove the outer case and the cover of the inner case, refer to Section 1.4 and 1.5.

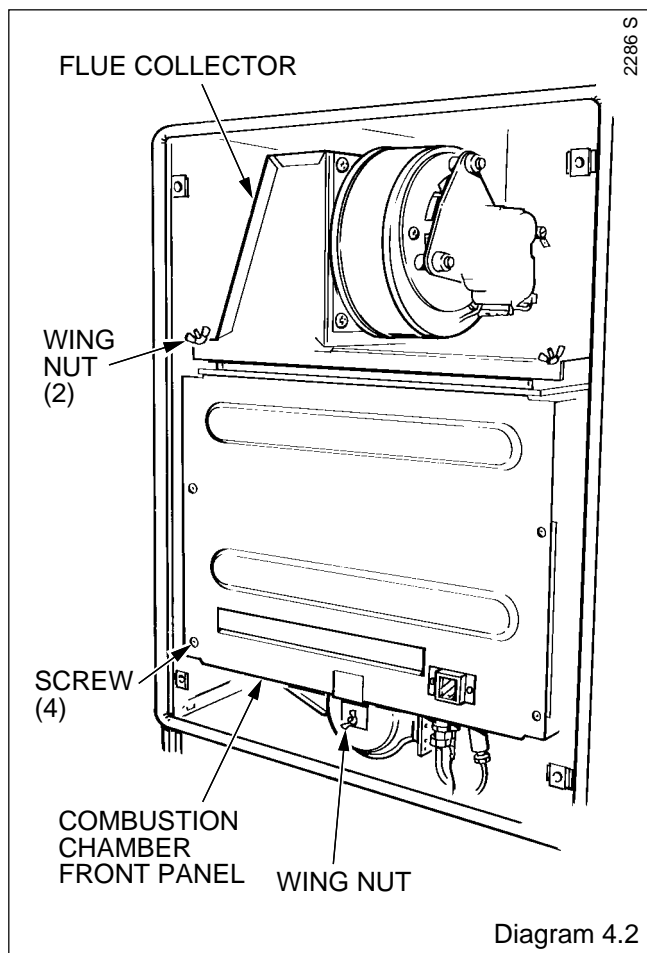
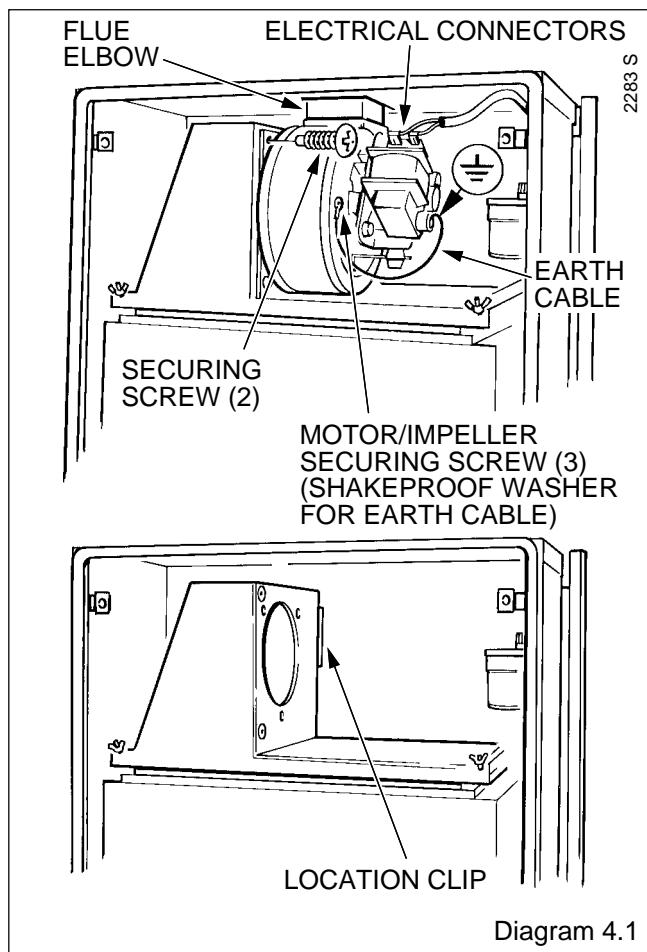

4 Replacement of Parts

Remove the main burner refer to Section 4.2.

Remove the sealing angle, secured with a single screw, see diagram 4.3.

Disconnect the ignition lead from the spark electrode.

Remove the spark electrode, secured with a single screw.

Disconnect the thermocouple nut from the pilot burner.

Disconnect the pilot supply tube, holding the pilot injector hexagon with another spanner, then remove the pilot burner.

Check the spark gap upon assembly, see diagram 4.4.

4.5 Spark Electrode

Before starting, refer to Section 1.1.

Isolate the boiler from the electrical supply, refer to Section 1.3.

Remove the outer case and the cover of the inner case, refer to Section 1.4 and 1.5.

Slacken the two wing nuts securing the flue collector, see diagram 4.2.

Remove the outer combustion chamber front panel, secured with the four screws and a wing nut.

Disconnect the ignition lead from the spark electrode, see diagram 4.3.

Remove the spark electrode, secured with a single screw.

Check the spark gap upon the assembly, see diagram 4.4.

4.6 Pilot Injector

Before starting, refer to Section 1.1

Isolate the boiler from the electrical supply, refer to Section 1.3.

Remove the outer case and the cover of the inner case, refer to Section 1.4 and 1.5.

Remove the main burner, refer to Section 4.2.

Remove the sealing angle, secured with a single screw, see diagram 4.3.

Disconnect the ignition lead from the spark electrode.

Remove the spark electrode, secured with a single screw.

Disconnect the thermocouple nut from the pilot burner.

Disconnect the pilot supply tube, holding the pilot injector hexagon with another spanner, then remove the pilot burner.

Remove the pilot injector from the pilot assembly by unscrewing it.

Check the pilot flame length on relighting, see diagram 4.4.

4.7 Thermocouple

Before starting refer to Section 1.1.

Isolate the boiler from the electrical supply, refer to Section 1.3.

Remove the outer case and the cover of the inner case, refer to Section 1.4 and 1.5.

Remove the main burner, refer to Section 4.2.

Remove the sealing angle secured with a single screw, see diagram 4.3.

Disconnect the ignition lead from the spark electrode.

Remove the control housing, secured with two screws. Support the control housing on a surface or by screwing it to the front edge of the base, using the outer case securing screw, see diagram 4.5.

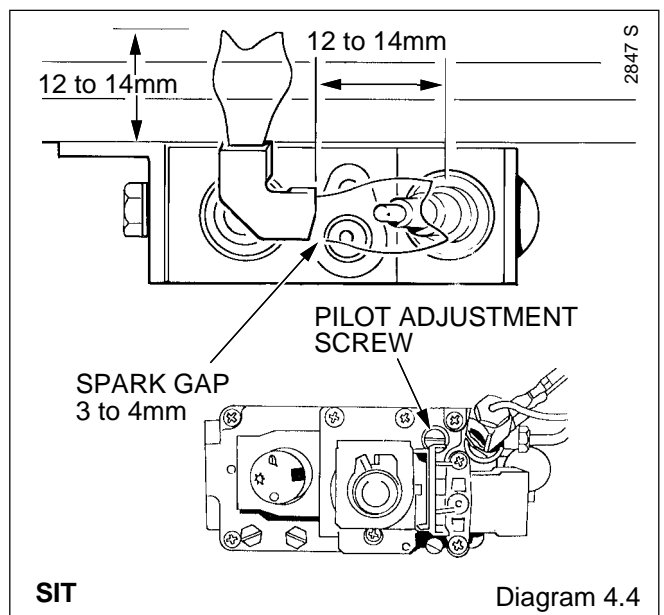
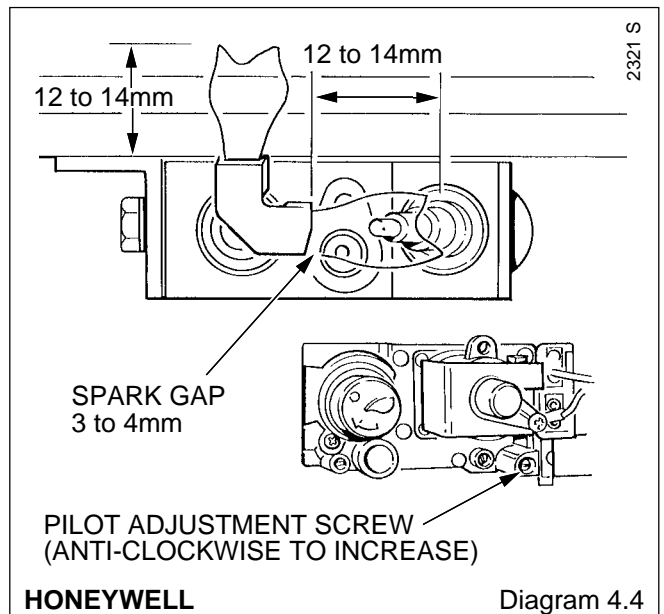
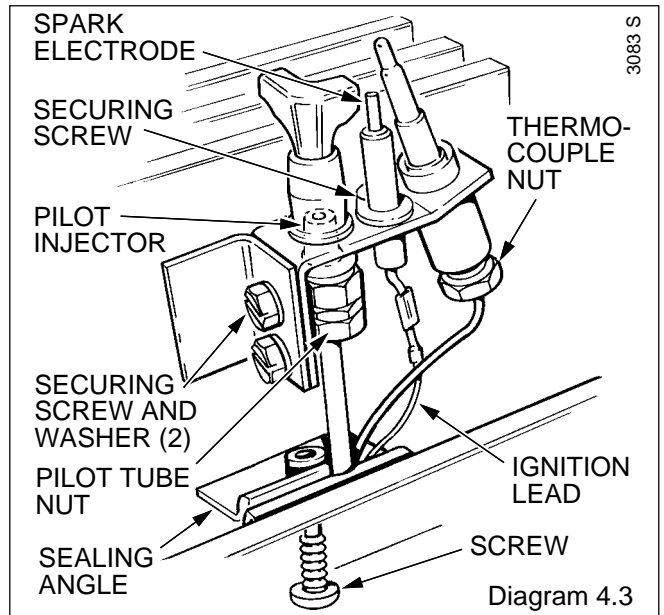

4 Replacement of Parts

Disconnect the pilot supply tube, holding the pilot injector hexagon with another spanner, see diagram 4.3.

Disconnect the thermocouple at both ends, see diagram 4.3 and 4.6.

Remove the pilot burner, secured with two screws, then remove the thermocouple.

Make sure that the overheat cutoff connector is in place in the slot of the gas valve when fitting the thermocouple. Do not tighten the thermocouple nut more than a quarter turn beyond finger tight or make any tight bends in the thermocouple capillary.

4.8 Boiler Overheat Cutoff

Before starting refer to Section 1.1

Isolate the boiler from the electrical supply, refer to Section 1.3.

Remove the outer case, refer to Section 1.4.

Gain access by removing the piezo bracket, disconnect lead, see diagram 4.12.

Disconnect the boiler overheat cutoff electrical connectors from the gas valve, see diagram 4.6.

Remove the overheat cutoff, secured with two screws.

Use a little of the heat sink compound supplied, between the mounting plate and the cutoff when fitting it.

4.9 Domestic Hot Water High Limit Control.

Before starting, refer to Section 1.1.

Isolate the boiler from the electrical supply, refer to Section 1.3.

Remove the outer case, refer to Section 1.4.

Remove the control housing, refer to Section 4.7 paragraph 7.

Disconnect the electrical connector at the domestic hot water high limit control, see diagram 4.8.

Remove the high limit control from the flow pipe, secured with two screws.

Use a little of the heat sink compound supplied, between the mounting plate and the control, when fitting it.

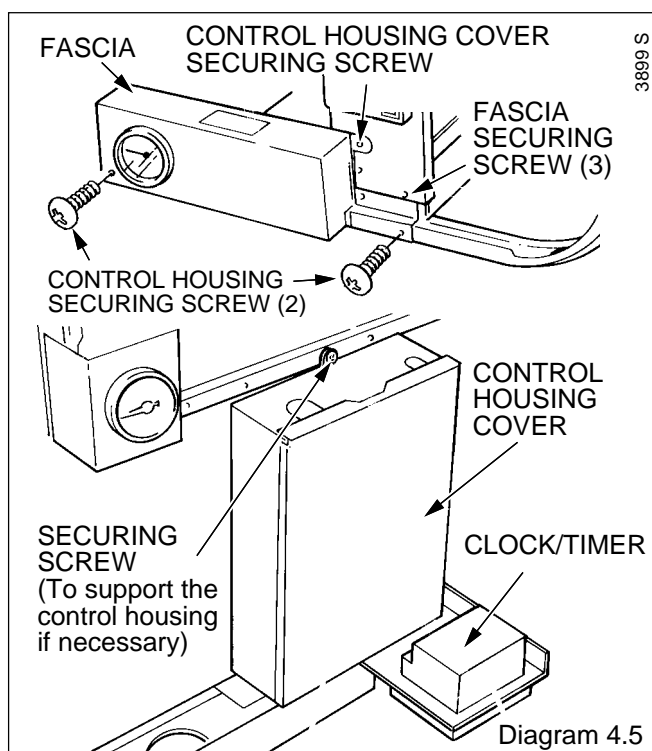

Diagram 4.5

4.10 Piezo Unit

Before starting refer to Section 1.1

Isolate the boiler from the electrical supply, refer to Section 1.3.

Remove the outer case, refer to Section 1.4.

Remove the piezo unit bracket, see diagram 4.12.

Disconnect the ignition lead at the piezo unit.

Remove the piezo unit from the bracket.

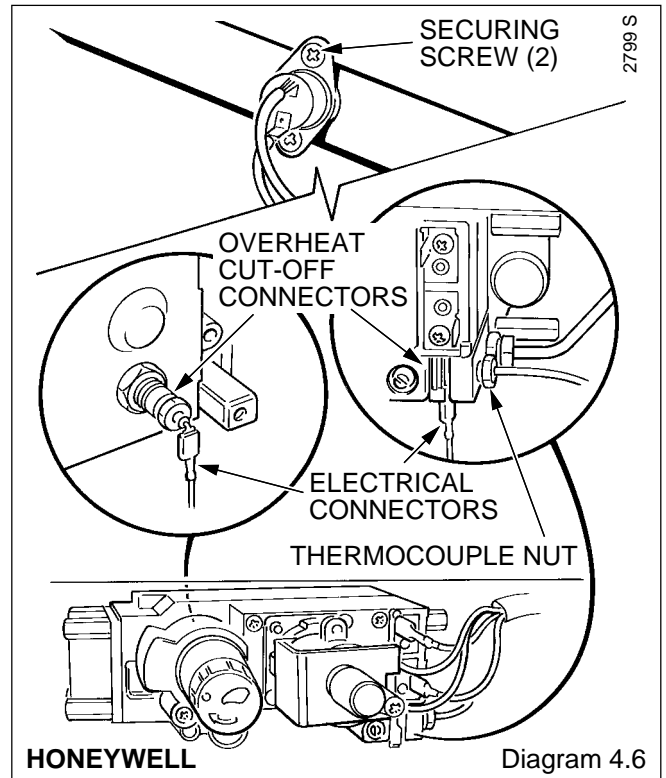

HONEYWELL

Diagram 4.6

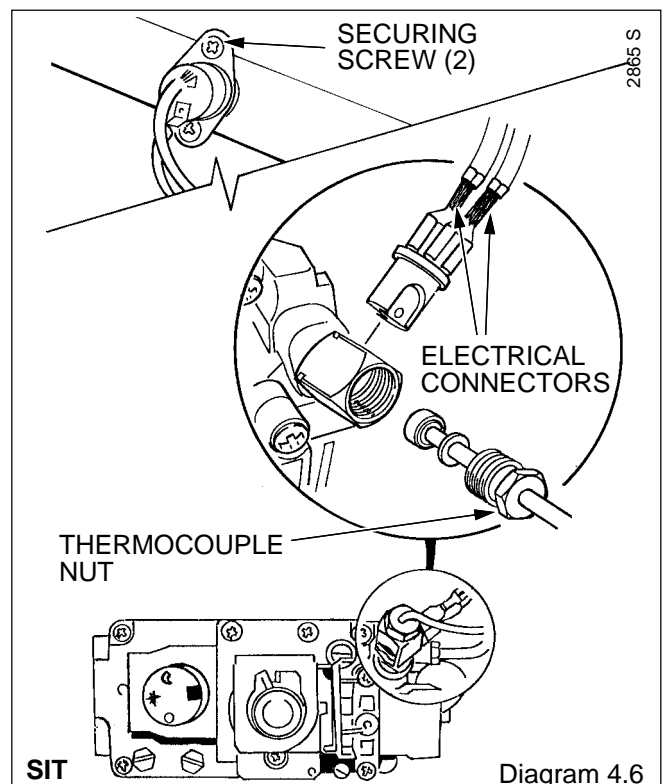

SIT

Diagram 4.6

4 Replacement of Parts

4.11 Ignition Lead

Before starting refer to Section 1.1.

Isolate the boiler from the electrical supply, refer to Section 1.3.

Remove the outer and inner case, refer to Section 1.4 and 1.5.

Disconnect the ignition lead at both ends and remove it. Take care not to damage the seals when passing the connectors between them.

Make sure that the clear insulated connector is fitted to the spark electrode and the lead follows the same route, being secured in the same manner as the original.

4.12 Pressure Gauge

Before starting, refer to Section 1.1.

Isolate the boiler from the electrical supply, refer to Section 1.3.

Remove the outer case, refer to Section 1.4.

Release the water pressure and drain the central heating circuit of the boiler, refer to Section 1.3 and 1.6.

Remove the control housing, refer to Section 4.7 paragraph 7.

Remove the pressure gauge bracket, see diagram 4.7.

Disconnect the pressure gauge connection from the safety valve, discard the sealing washer.

Remove the pressure gauge secured with the retaining spring tabs.

Locate the supplied sealing washer under the pressure gauge connection when it is fitted to the safety valve.

Make up the water loss and pressurise the system, refer to Commissioning in the Installation Instructions.

4.13 Control Boards

Before starting refer to Section 1.1.

Isolate the boiler from the electrical supply, refer to Section 1.3.

Remove the outer case, refer to Section 1.4.

Remove the clock mounting bracket securing screws, see diagram 4.8A.

Remove control housing cover, temperature control knob and the fascia, see diagram 4.5.

Remove the control housing assembly, see Section 4.13.

Disconnect all the multi-pin connectors, see diagram 4.9.

Remove the control boards from the support post, noting the correct positions. Great care must be taken when handling any control board.

THEY MUST BE KEPT IN THE ANTI-STATIC HOLDER UNTIL IMMEDIATE REQUIREMENT.

To connect the multi-pin connector correctly, see diagram 4.10.

Check and adjust the main burner gas pressure in the hot water and central heating modes, if necessary, refer to Commissioning in the Installation Instructions.

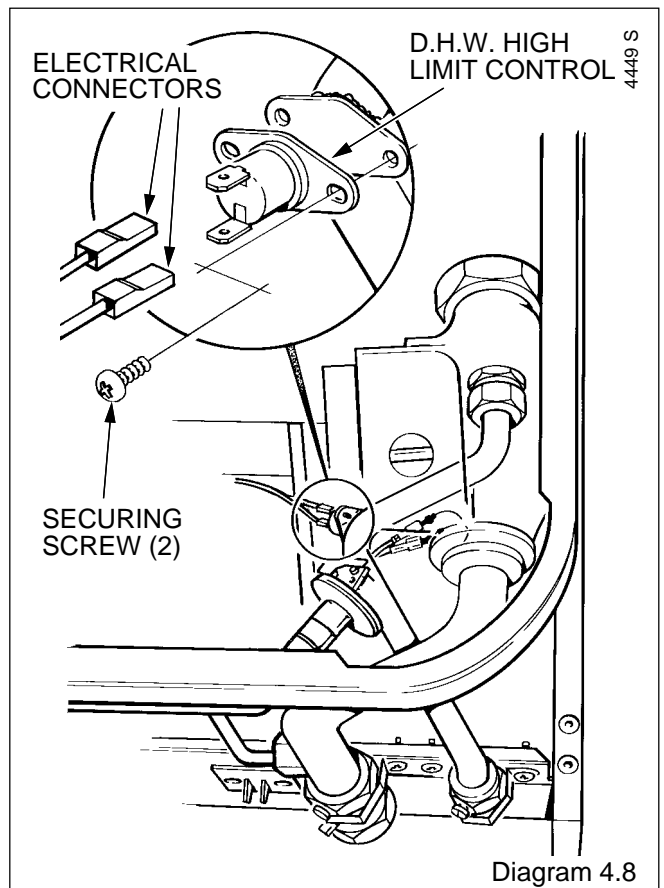
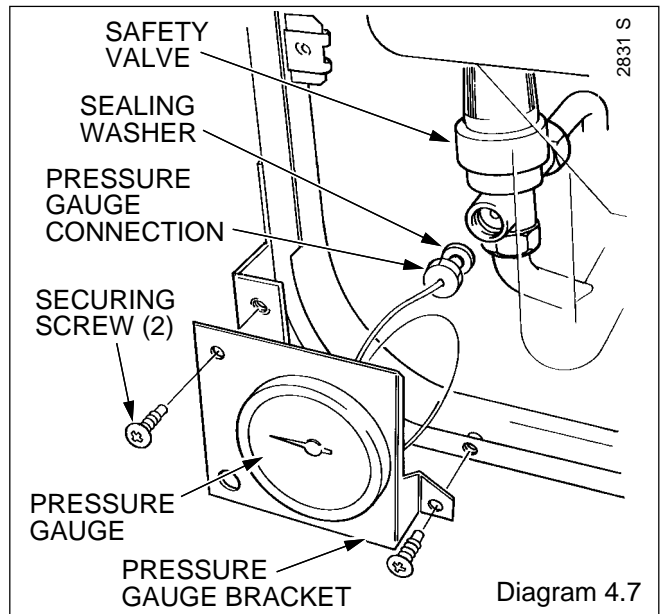

4.14 Clock/Timer - if fitted

ELECTRO/MECHANICAL and DIGITAL clock/timer - Release the mounting bracket securing screws, see diagram 4.8A.

Disconnect electrical cables, release securing clip to remove the clock timer and spacer, see diagram 4.8B.

4 Replacement of Parts

4.15 Transformer

Before starting, refer to Section 1.1

Isolate the boiler from the electrical supply, refer to Section 1.3

Remove the outer case, refer to Section 1.4.

Remove the control housing and cover, refer to Section 4.13.

Support the control housing, see diagram 4.5.

Disconnect the electrical connectors from the transformer, see diagram 4.9.

Remove the transformer, noting the correct position.

To connect the transformer cables correctly, see diagram 4.10.

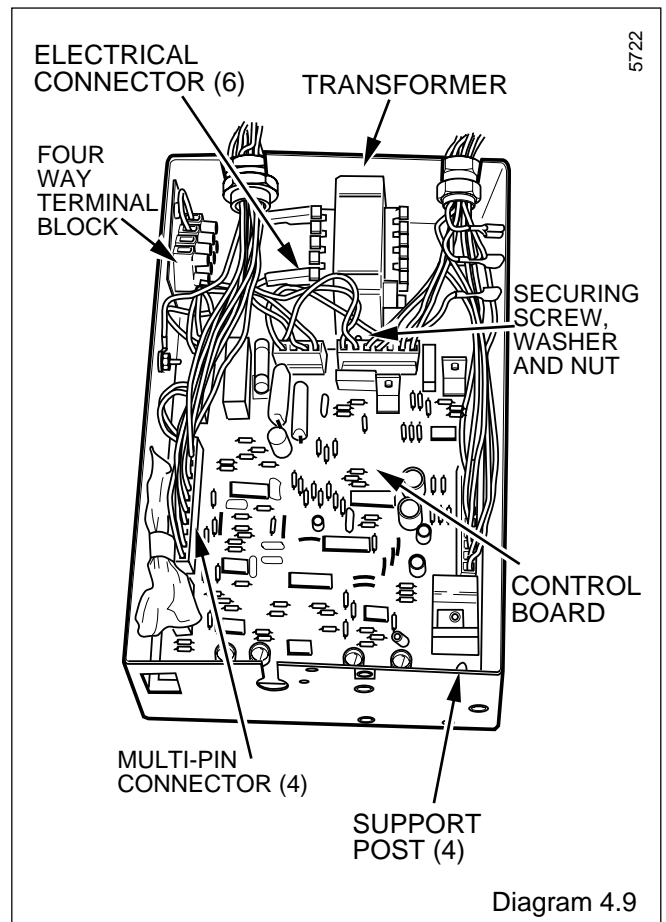
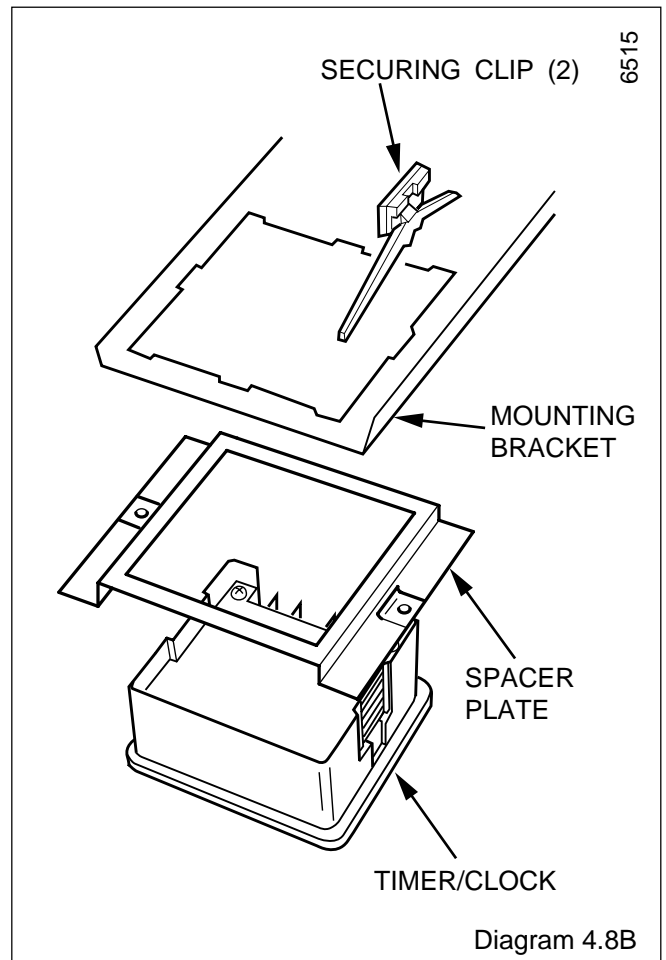
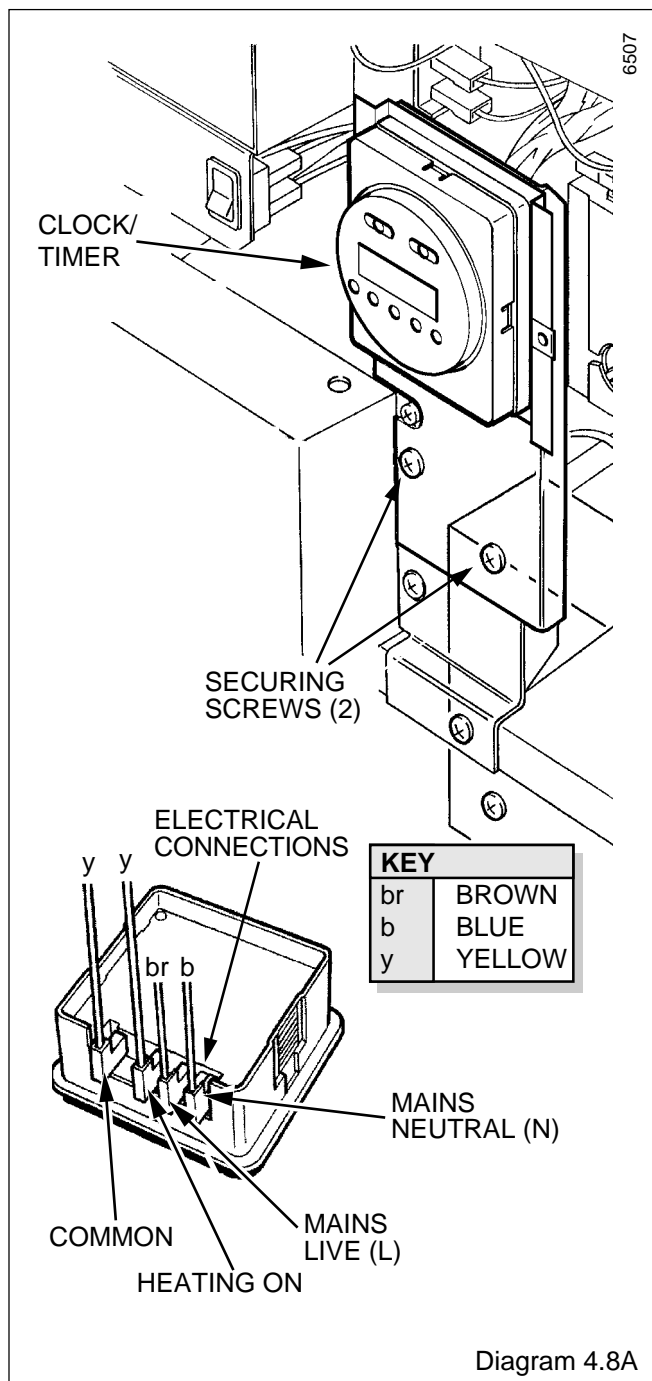

4 Replacement of Parts

6080

240V-50Hz PERMANENT
MAINS SUPPLY FUSED

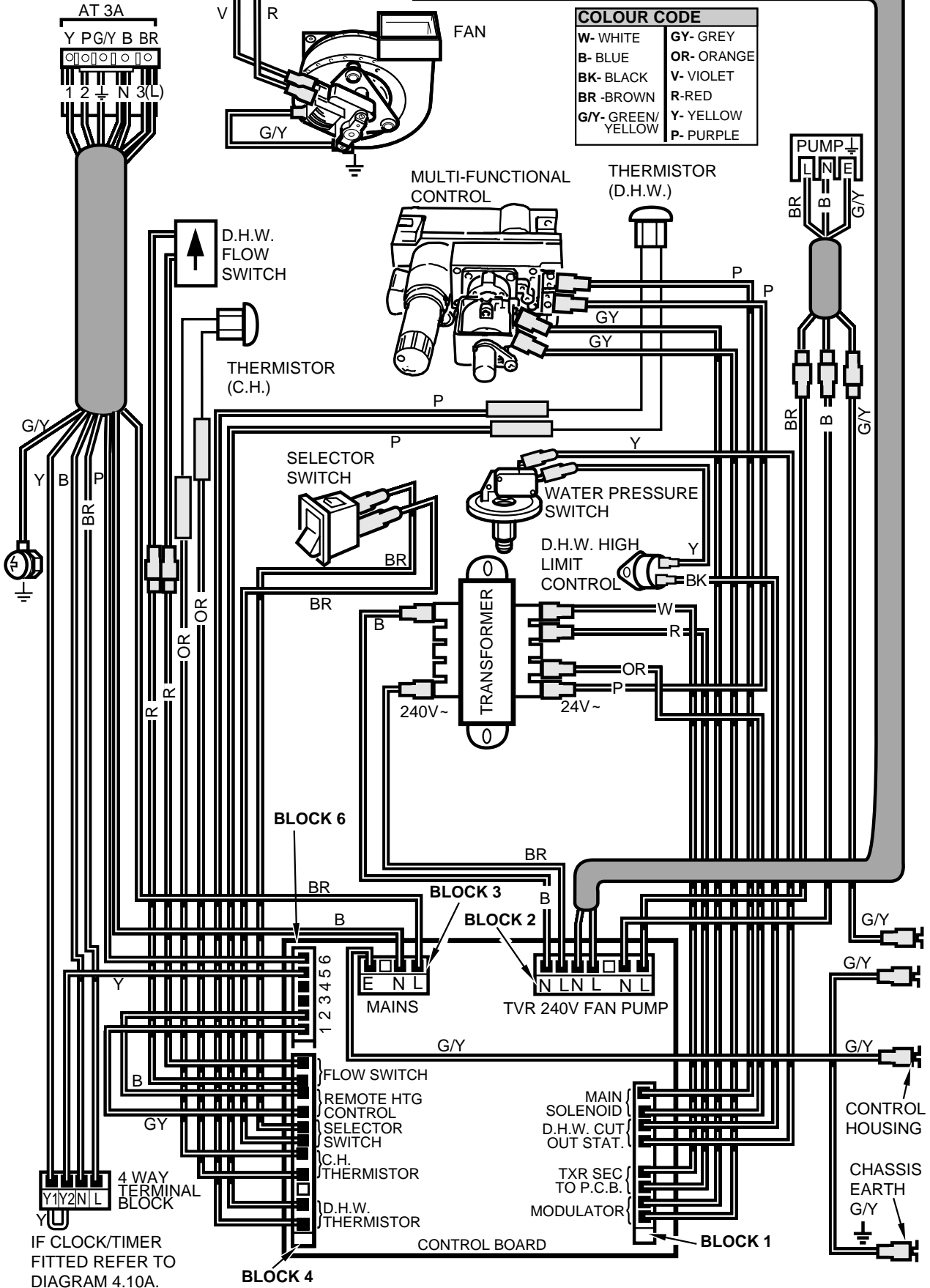

IF CLOCK/TIMER
FITTED REFER TO
DIAGRAM 4.10A.

HONEYWELL

Diagram 4.10

4 Replacement of Parts

6081

240V-50Hz PERMANENT
MAINS SUPPLY FUSED
AT 3A

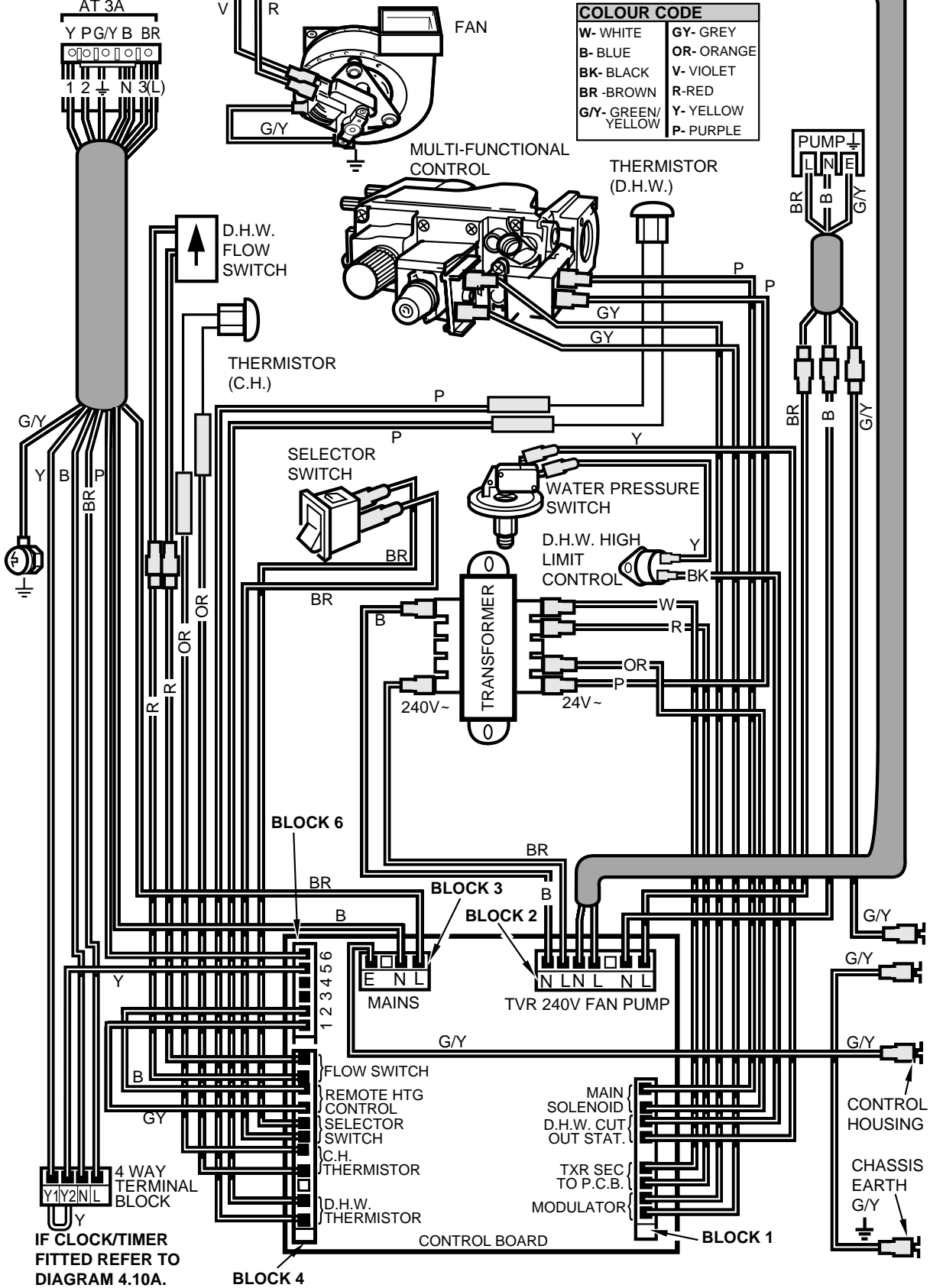

IF CLOCK/TIMER
FITTED REFER TO
DIAGRAM 4.10A.

SIT

Diagram 4.10

4 Replacement of Parts

5725

WIRING AS
DIAGRAM 4.10

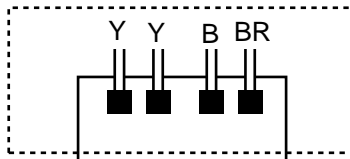

* Note:
Remove
'Yellow Link'
before fitting
Clock/Timer

4 WAY
TERMINAL
BLOCK

CLOCK /
TIMER

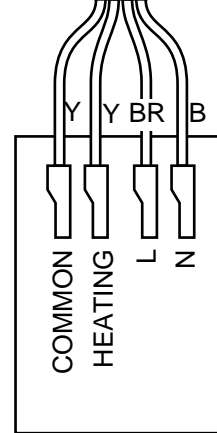

Diagram 4.10A

4 Replacement of Parts

4.16 Gas Valve - Honeywell



Before starting refer to Section 1.1.

Isolate the boiler from the electrical supply and close the gas service cock, refer to Section 1.3.

Remove the outer case, refer to Section 1.4.

Remove the control housing, refer to Section 4.7 paragraph 7.

Remove the piezo unit bracket, see diagram 4.12.

Disconnect the five electrical connectors, four at the front of the gas valve and one at the rear, see diagram 4.11.

Disconnect the thermocouple at the gas valve.

Disconnect the pilot supply tube at the gas valve.

Remove the four extended hexagon screws at the right of the valve.

Support the gas valve, disconnect the union nut of the gas service cock and remove the valve complete with inlet pipe.

Separate the valve from the pipe, noting the fitted position.

Transfer the pilot tube adapter and the overheat cutoff connectors to the replacement valve.

Discard the "O" rings and fit the new ones supplied, when fitting the gas valve.

To connect the gas valve cables correctly, see diagram 4.10.

Light and adjust the boiler if necessary, refer to Commissioning in the Installation Instructions. Adjust the pilot flame if necessary, refer to Section 4.4, Pilot Burner.

Check and adjust the main burner pressure in the hot water and central heating modes, refer to Commissioning in the Installation Instructions.

4.16 Gas Valve - SIT



Before starting refer to Section 1.1.

Isolate the boiler from the electrical supply and close the gas service cock, refer to Section 1.3.

Remove the outer case, refer to Section 1.4.

Remove the control housing, refer to Section 4.7, paragraph 7.

Remove the piezo bracket, see diagram 4.12.

Disconnect the four electrical connectors at the front of the gas valve and the boiler overheat cutoff connectors, see diagram 4.11.

Disconnect the thermocouple at the gas valve.

Disconnect the pilot supply tube at the gas valve.

Remove the four extended hexagon screws at the right hand of the gas valve.

Support the gas valve, disconnect the union nut of the gas service cock and remove the valve complete with inlet pipe.

Separate the valve from the pipe. noting the fitted position.

Discard the "O" rings and fit the new ones supplied.

To connect the gas valve cables correctly, see diagram 4.10.

If necessary adjust the pilot flame, refer to Section 4.4.

Check and adjust the main burner gas pressure in both the hot water and central heating mode, refer to Commissioning in the Installation Instructions.

4.17 Central Heating Selector Switch

Before starting refer to Section 1.1

Isolate the boiler from the electrical supply and close the gas service cock, refer to Section 1.3.

Remove the outer case, refer to Section 1.4.

Slacken the piezo bracket securing screws and remove the bracket from the keyhole slots, see diagram 4.12. Take care not to strain the piezo and electrical leads.

Pull the leads off from the switch, see diagram 4.12.

To remove the switch press the retaining tabs at the sides.

The polarity of the electrical connections is not important.

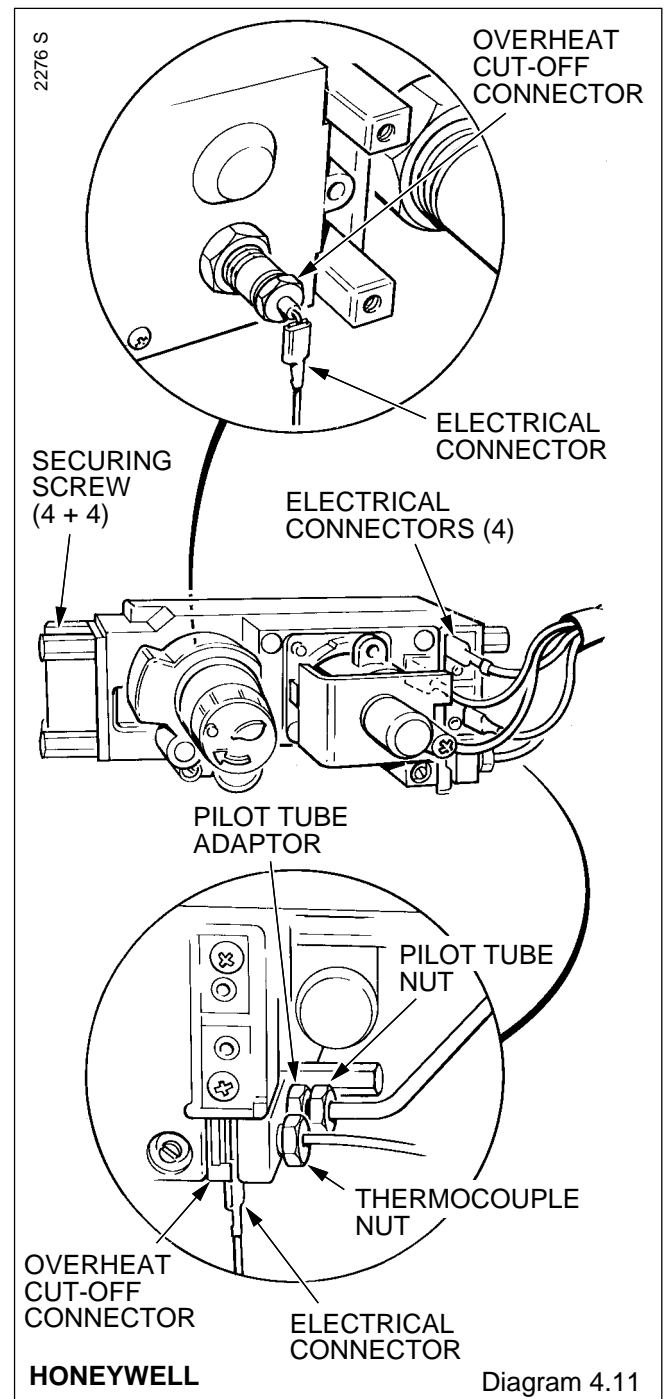

4 Replacement of Parts

4.18 Modulator - Honeywell

Before starting refer to Section 1.1.

Isolate the boiler from the electrical supply and close the gas service cock, refer to Section 1.3.

Remove the outer case, refer to Section 1.4.

Disconnect the two electrical connectors at the modulator, see diagram 4.13.

Remove the modulator, secured with two screws.

Discard the gasket and fit the new one supplied, when fitting the modulator.

Light, check and adjust the boiler if necessary, refer to Commissioning in the Installation Instructions.

4.19 Modulator - SIT

Disconnect the two electrical connections at the modulator, see diagram 4.13. Unscrew the centre shaft nut "A" and remove the modulator coil.

Check and if necessary, adjust the boiler, refer to Commissioning in the Installation Instructions.

The polarity of the electrical connections is not important.

4.19 Solenoid - SIT

Disconnect the two electrical connectors at the solenoid, see diagram 4.13.

Remove the two solenoid securing screws and remove the solenoid.

The polarity of the electrical connections is not important.

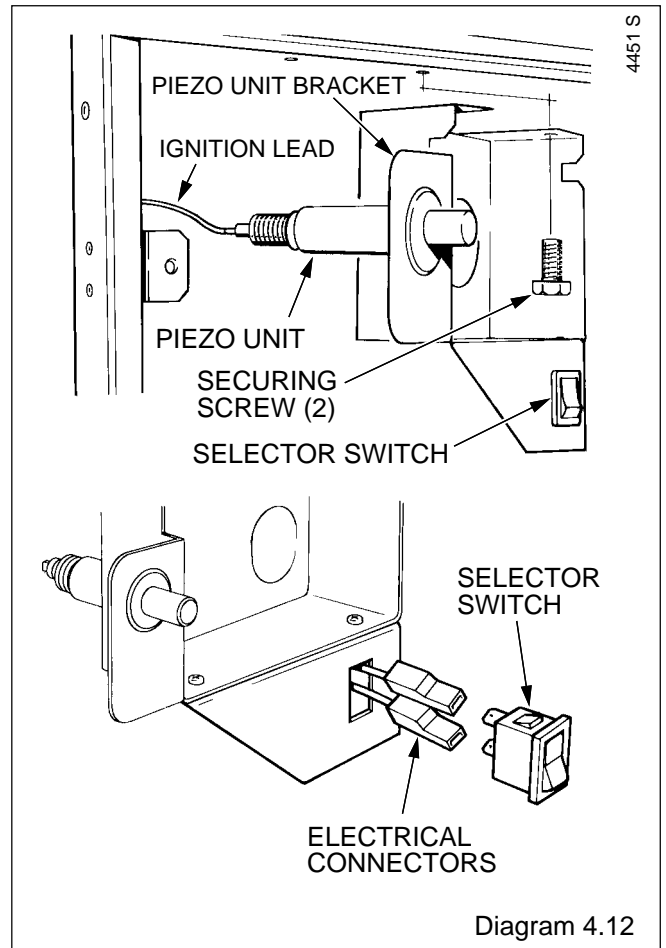

Diagram 4.12

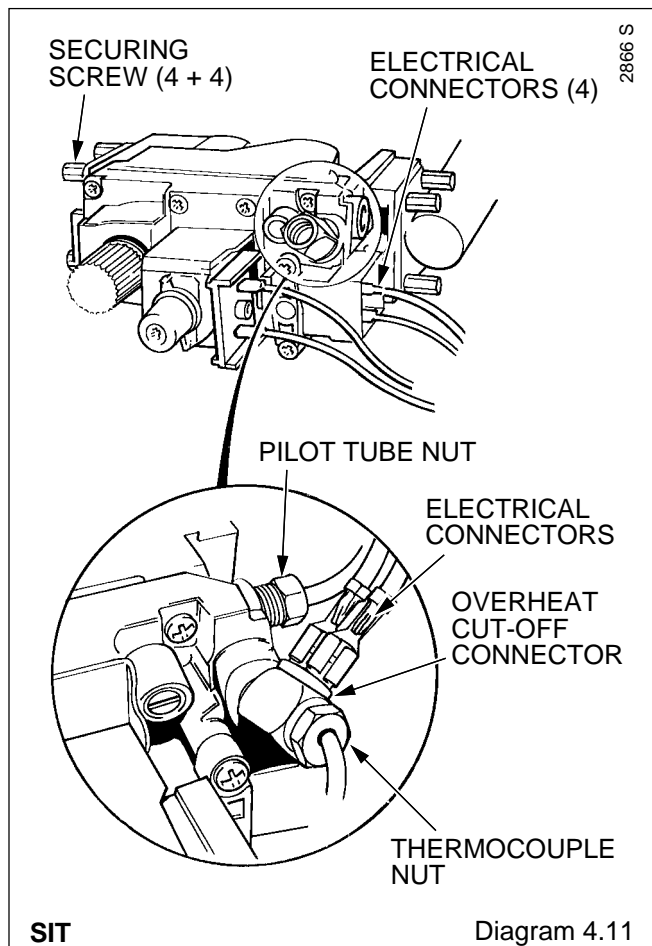

Diagram 4.11

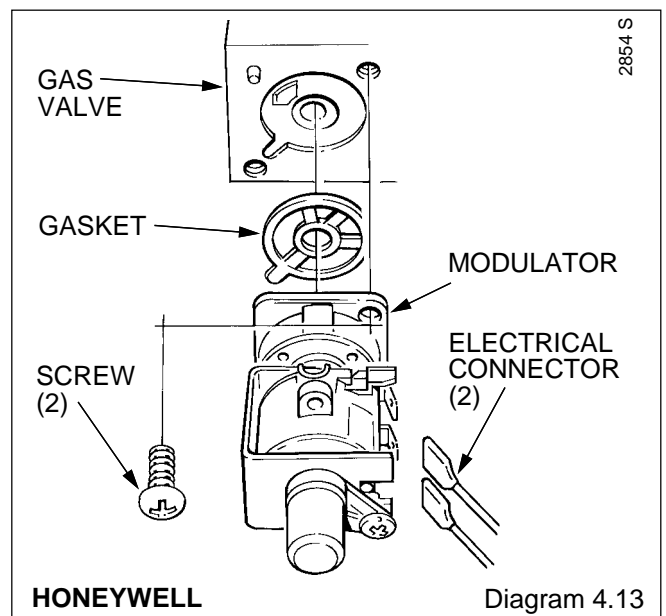

Diagram 4.13

4 Replacement of Parts

4.20 Domestic Hot Water Flow Switch

Before starting refer to Section 1.1.

Isolate the boiler from the electrical supply, refer to Section 1.3.

Remove the outer case, refer to Section 1.4.

Isolate the domestic water inlet, release the domestic water pressure and drain, refer to Section 1.3 and 1.6.

Remove the control housing, refer to Section 4.7 paragraph 7.

Remove the piezo unit bracket, see diagram 4.12.

Remove the pressure gauge bracket, see diagram 4.7.

Disconnect the flow switch cables at the in line electrical connectors.

Remove the flow switch by disconnecting the union nuts, see diagram 4.14, noting the fitted position. Slacken or remove the clip securing the isolating valve to ease removal.

Discard the sealing washer and use the new ones supplied, when fitting the flow switch. It is recommended that the water inlet filter is cleaned or renewed at this stage. Make sure that the switch is positioned correctly, with the flow arrow pointing upward.

4.21 Thermistor

Before starting refer to Section 1.1.

Isolate the boiler from the electrical supply, refer to Section 1.3.

Remove the inner case, refer to Section 1.4.

Release the water pressure and drain the appropriate circuit of the boiler, refer to Section 1.6.

Gain access, central heating thermistor only, by removing the piezo bracket, see diagram 4.12.

Remove the control housing, refer to Section 4.7 paragraph 7.

Disconnect the cables from the appropriate thermistor connectors, see diagram 4.15.

Remove the relevant thermistor, complete with "O" ring.

Discard the "O" ring and use the new one supplied, when fitting the thermistor.

Make up water loss and pressurise the system, central heating thermistor only, refer to Commissioning in the Installation Instructions.

4.22 Safety Valve

Before starting, refer to Section 1.1.

Isolate the boiler from the electrical supply, refer to Section 1.3.

Remove the outer case, refer to Section 1.4.

Release the water pressure and drain, refer to Section 1.6.

Remove the control housing, refer to Section 4.7 paragraph 7.

Gain access by removing the pressure gauge bracket, see diagram 4.7.

Disconnect the pressure gauge connection from the safety valve, see diagram 4.16.

Disconnect the union nuts to release the safety valve.

Discard the sealing washers and use the new ones supplied, on assembly.

Make up water loss and pressurise the system, refer to Commissioning in the Installation Instructions.

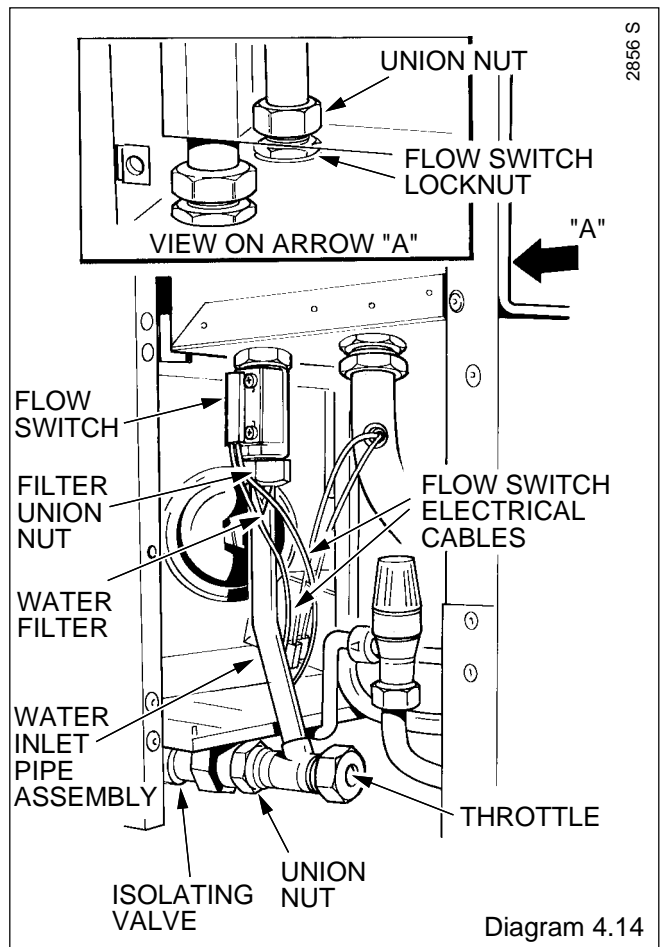
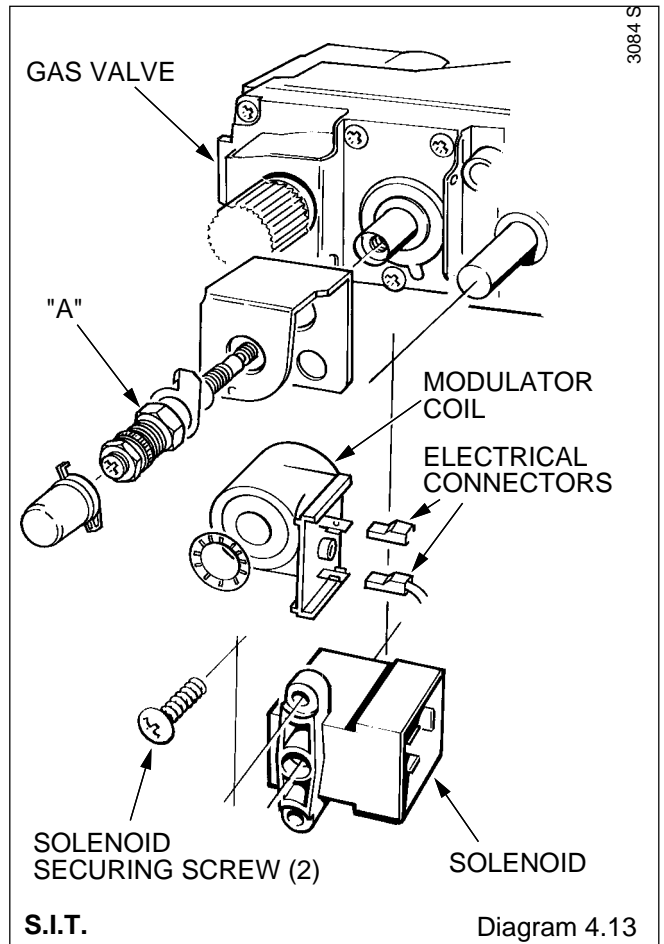

4 Replacement of Parts

4.23 Water Inlet Filter

Before starting refer to Section 1.1.

Isolate the boiler from the electrical supply, refer to Section 1.3.

Remove the outer case, refer to Section 1.4.

Isolate domestic water inlet, release the domestic water pressure and drain, refer to Section 1.3 and 1.6.

Remove the control housing, refer to Section 4.7 paragraph 7.

Disconnect the two union nuts to gain access to the filter, see diagram 4.14.

Clean or renew the filter as necessary.

Discard the sealing washer and use the new one supplied, on assembly.

4.24 Domestic Hot Water Throttle

Before starting refer to Section 1.1

Isolate the boiler from the electrical supply, refer to Section 1.3.

Remove the outer case, refer to Section 1.4.

Isolate the domestic water inlet, release the domestic water pressure and drain, refer to Section 1.3 and 1.6.

Remove the cap nut and carefully remove the throttle adjuster, see diagram 4.17.

Clean if necessary, taking care not to damage the throttle body.

Discard the "O" ring and use the new ones supplied, when fitting the throttle adjuster.

4.25 Mini Expansion Vessel

Before starting, refer to Section 1.1.

Isolate the boiler from the electrical supply, refer to Section 1.3.

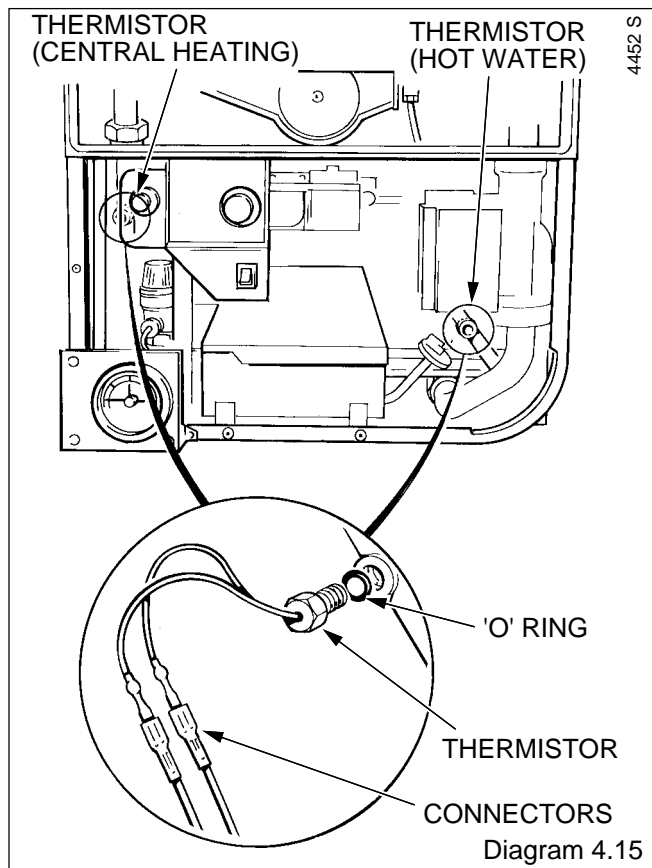

Remove the outer case, refer to Section 1.4.

Isolate domestic water inlet, release the domestic water pressure and drain, refer to Section 1.3 and 1.6.

Remove the control housing, refer to Section 4.7 paragraph 7.

Remove the mini expansion vessel, see diagram 4.18.

Discard the sealing washer and use the new one supplied, when fitting.

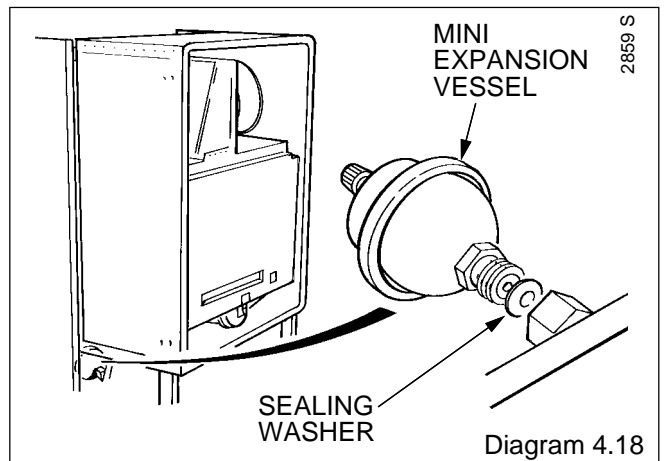
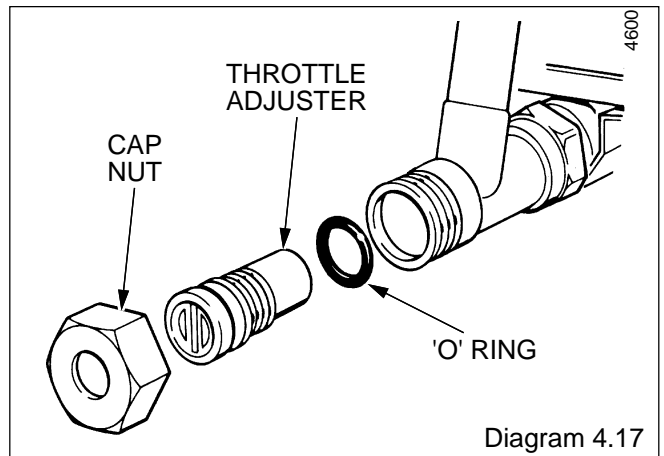
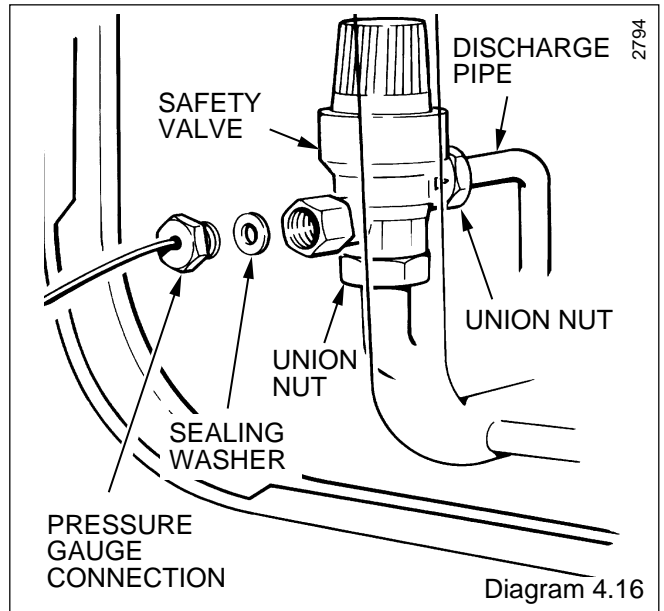

4 Replacement of Parts

4.26 Pump

Before starting refer to Section 1.1.

Isolate the boiler from the electrical supply, refer to Section 1.3.

Remove the outer case, refer to Section 1.4.

Release the water pressure and drain, refer to Section 1.6.

Remove the control housing, refer to Section 4.7 paragraph 7.

Disconnect the electrical connectors at the pressure switch microswitch. See diagram 4.21.

Remove pressure switch, see diagram 4.21.

Remove the terminal cover from the pump and disconnect the cables, see diagram 4.19.

Disconnect the pump at the unions, see diagram 4.19.

Discard the sealing washers.

Make sure that the flow direction arrow is pointing upward, on the pump, when fitting it to the lower pipework, using the new sealing washers provided.

Refit pressure switch. Use jointing compound to ensure a sound joint.

Set the flow adjuster on the pump to maximum setting. The flow rate should be controlled by means of a valve in the heating system.

Make up water loss and pressurise the system, refer to Commissioning in the Installation Instructions.

Note: Should the pump fail to work, see diagram 3.7. If all is in order but the pump still does not work, remove the screw, see diagram 4.19 then turn the pump spindle to release any temporary seizure. DO NOT HIT THE SPINDLE.

4.27 Automatic Air Vent

Before starting refer to Section 1.1.

Isolate the boiler from the electrical supply, refer to Section 1.3.

Remove the outer case and the cover of the inner case, refer to Sections 1.4 and 1.5.

Release the water pressure and drain, refer to Section 1.6.

Remove the automatic air vent, see diagram 4.20.

Discard the sealing washer and use the new one supplied, when fitting.

Slacken the small cap on the air vent. This MUST NOT be retightened.

Make up water loss and pressurise the system, refer to Commissioning in the Installation Instructions.

4.28 Pressure Switch

Before starting refer to Section 1.1

Isolate the boiler from the electrical supply, refer to Section 1.3.

Remove the outer case, refer to Section 1.4.

Release the water pressure and drain, refer to Section 1.6.

Remove the control housing, refer to Section 4.7 paragraph 7.

Disconnect the electrical connectors at the microswitch, see diagram 4.21.

Remove pressure switch see diagram 4.21.

On assembly use jointing compound to ensure a sound joint.

Make up water loss and pressurise the system, refer to Commissioning in the Installation Instructions.

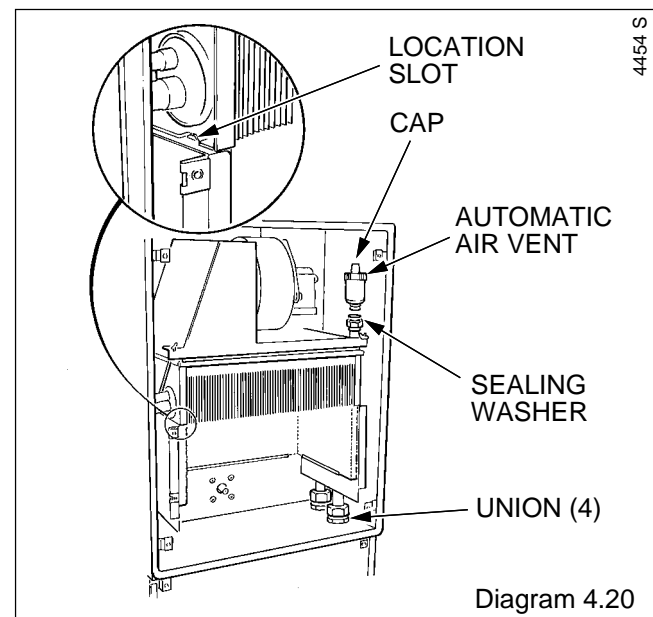
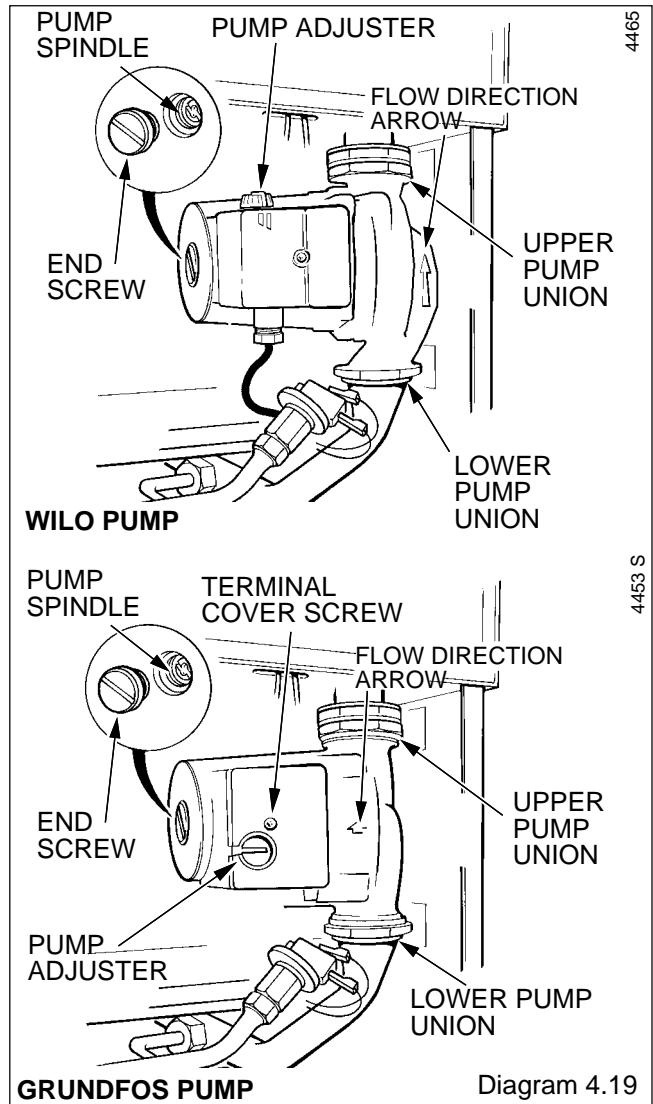

4 Replacement of Parts

4.29 Heat Exchanger

Before starting refer to Section 1.1

Isolate the boiler from the electrical supply and close the gas service cock, refer to Section 1.3.

Remove the outer case and the cover of the inner case, refer to Section 1.4. and 1.5.

Release the water pressure and drain, refer to Section 1.6.

Remove the fan from the flue collector, refer to Section 4.1.

Remove the flue collector, secured with two wing nuts and hook bolts, see diagram 4.2.

Remove the main burner, refer to Section 4.2.

Remove the automatic air vent, see diagram 4.20.

If renewing the heat exchanger, transfer the air vent to the new one, using the new sealing washers supplied.

Disconnect the union nuts of the heat exchanger to remove it.

Discard the sealing washers and use the new ones supplied, upon assembly.

Locate the raised location tabs on the combustion chamber sides into the slots on the heat exchanger, when fitting.

Make sure that the main burner is located on the main injector and is horizontal, the tips of the rear most blade under the two burner guides.

The combustion chamber front panel should be fitted loosely, then the flue collector also fitted loosely, ensuring that it is seated correctly on the heat exchanger and over the top edge of the front panel.

Locate the fan into the flue elbow and the clip at the rear, then secure with the two screws.

Connect the cables, the polarity of the two connectors is not important.

Tighten the wing nuts and screws evenly to secure the flue collector and combustion chamber front panel.

Make up water loss and pressurise the system, refer to Commissioning in the Installation Instructions.

4.30 Combustion Chamber Insulation

Before starting refer to Section 1.1.

Isolate the boiler from the electrical supply and close the gas service cock, refer to Section 1.3.

Remove the outer case and the cover of the inner case, refer to Section 1.4 and 1.5.

Remove the fan, refer to Section 4.1.

Remove the flue collector, secured with two wing nuts and hook bolts, see diagram 4.2.

Remove the combustion chamber front panel, secured with four screws and a wing nut.

Remove the front insulation panel, secured with a clip, see diagram 4.22.

Slide out both side insulation pieces.

Pull the lower rear insulation forwards, then slide the upper rear insulation down from behind the heat exchanger.

To fit the flue collector, combustion chamber front panel and fan, refer to Section 4.29.

4.31 Expansion Vessel

Renewal of the expansion vessel requires the boiler to be removed from the wall. As an alternative, in certain circumstances, a separate expansion vessel of the same specification may be connected as close as possible to the boiler, leaving the original in position.

Before starting refer to Section 1.1

Isolate the boiler from the electrical supply and close the gas service cocks, refer to Section 1.3.

Remove the outer case and the cover of the inner case, refer to Section 1.4. and 1.5.

Release the water pressure and drain, refer to Section 1.6.

Remove the fan from the flue collector, refer to Section 4.1.

Remove the flue elbow, secured to the boiler with four screws and to the air duct with two screws, see diagram 4.23.

Disconnect the boiler water connection union nuts at the front of the isolating valves, see diagram 1.1.

Disconnect the gas service cock union.

Disconnect the safety valve discharge compression fitting nut at the rear of the boiler.

Separate the two parts of the boiler multi-pole connector.

Slacken the clips of the gas service cock and isolating valves.

Remove the boiler from the mounting frame, secured with two screws at the top, see diagram 4.23. Pull the boiler from the isolating valves and clips at the bottom, taking care not to loose the water filter from inside the boiler inlet. Unhook the boiler at the top and withdraw it forwards.

Carefully lay the boiler down on its side to gain access to the expansion vessel.

Disconnect the union nut connection, see diagram 4.24.

Remove the expansion vessel, secured with three clamps.

Discard the sealing washer and use the new one supplied, when fitting.

Connect the union nut, when fitting the expansion vessel, before clamping it.

To fit the flue collector, combustion chamber front panel and fan, refer to Section 4.29.

Make up water loss and pressurise the system, refer to Commissioning in the Installation Instructions.

Reminder - Leave these instructions with the user.

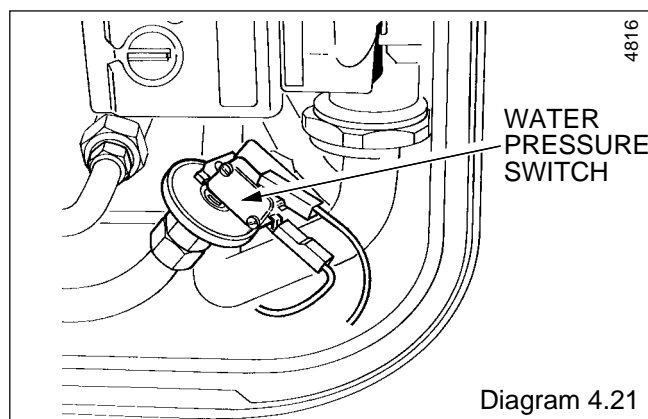
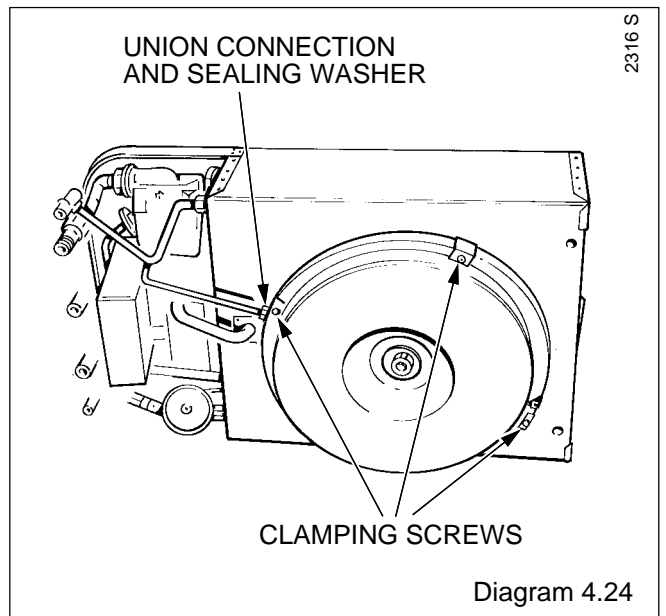
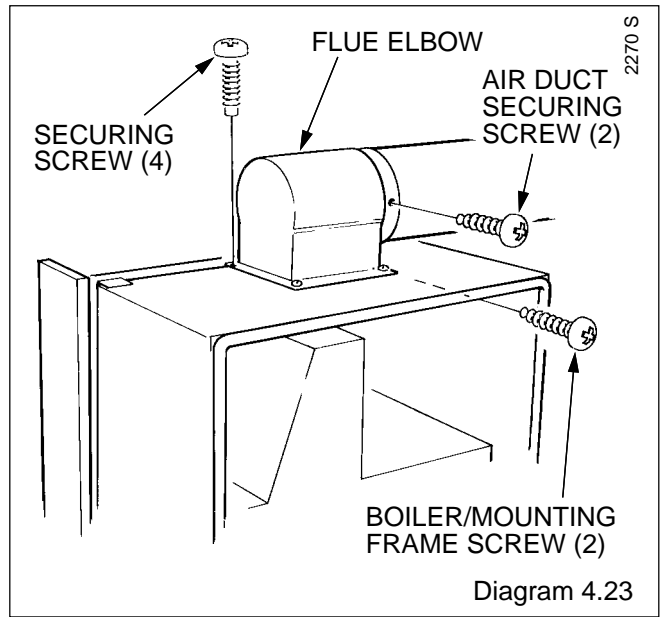
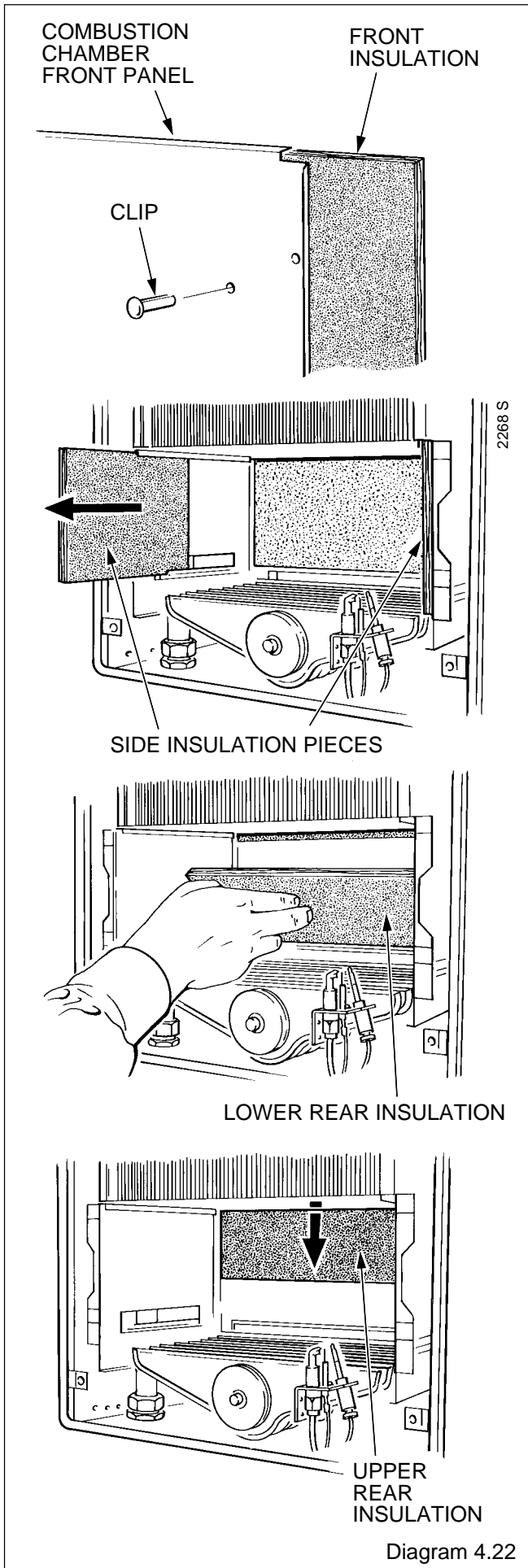

Diagram 4.21

4 Replacement of Parts



5 Spare Parts

5.1 Part Identification

The key number in diagram 5.1 and the first column of the list will help identify the spare part.

5.2 Ordering

When ordering any spare part, please quote the part number and the description from the list together with the model name and serial number information from the data label. The data label is positioned on the inner case cover, visible when the outer case is removed, see diagram 1.3.

Key No.	Part No.	Description	G.C. No.
1	432828	Fan impeller and motor	376 976
2	203027	Main injector assembly	398 239
3	203425	Pilot burner	376 967
4	202616	Spark electrode	383 724
5	203516	Pilot injector	376 968
6	202425	Thermocouple	383 719
7	432869	Boiler overheat cutoff assembly	376 988
8	432868	Domestic hot water limit control	313 024
9	900501	Piezo unit	384 146
10	WW4604	Ignition lead	360 211
11	432874	Pressure gauge assembly	313 014
12	800877	Control board (inc 19,20)	
13	800322	Transformer	313 761
14	432870	Gas valve assembly - Honeywell	376 964
14	800158	Gas valve assembly - SIT	313 237
15	203345	Modulator assembly - Honeywell	313 021
15	800154	Modulator coil - SIT	313 414
16	202068	Central heating selector switch	382 813
17	432867	Thermistor assembly	376 987
18	800136	Domestic hot water switch assembly	313 277
19	202107	Fuse 2 type T 630mA	313 087
20	202114	Fuse 1 type T1.6A	313 068
21	202115	Pressure switch	313 097
22	800376	Solenoid coil - SIT	

5 Spare Parts

4705

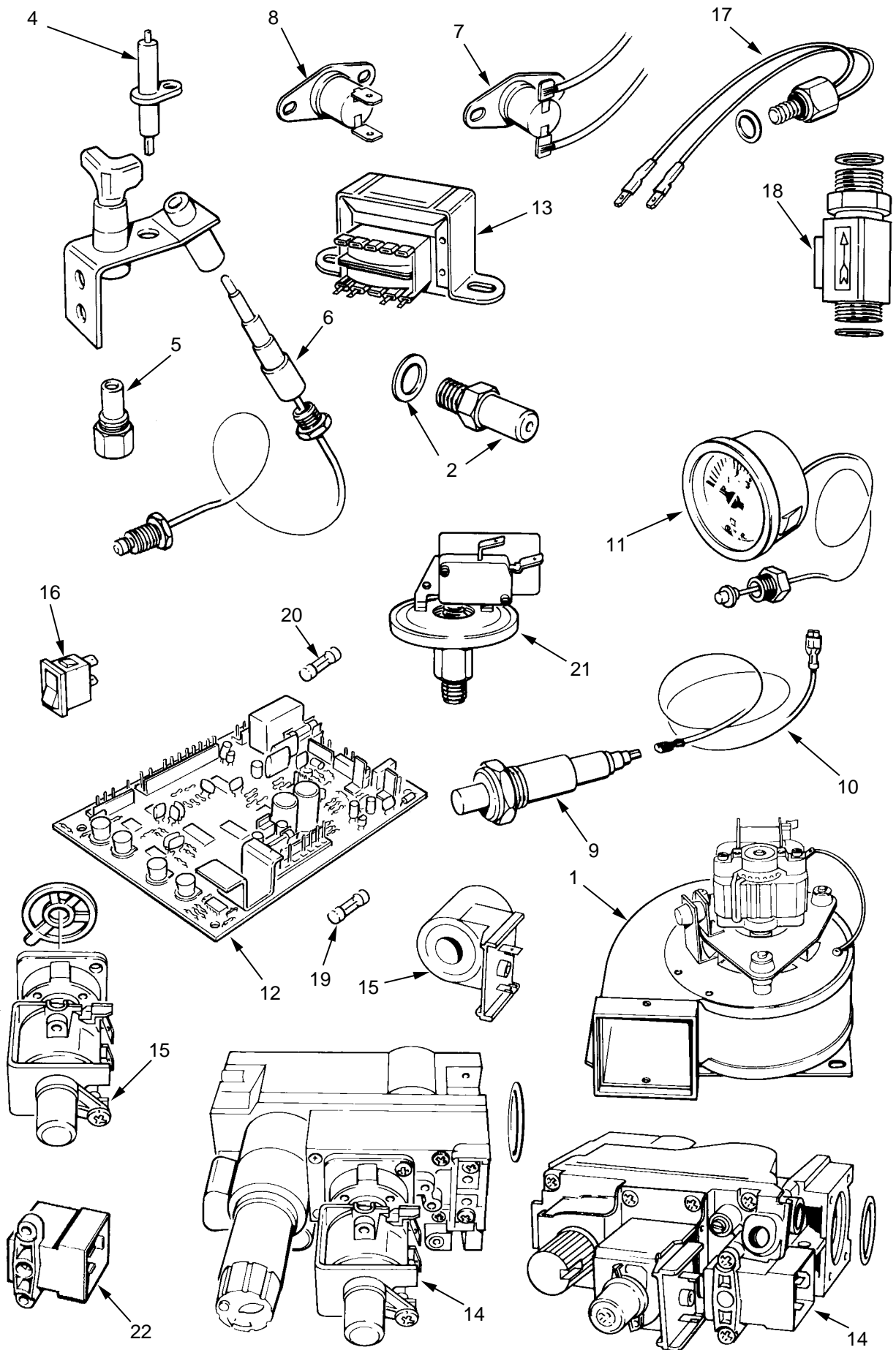

Diagram 5.1

Because of our constant endeavour for improvement, details may vary slightly from those shown in these instructions.