

Grant Vortex Eco

Internal Wall Hung Condensing Oil Boiler Range

Installation and Servicing Instructions

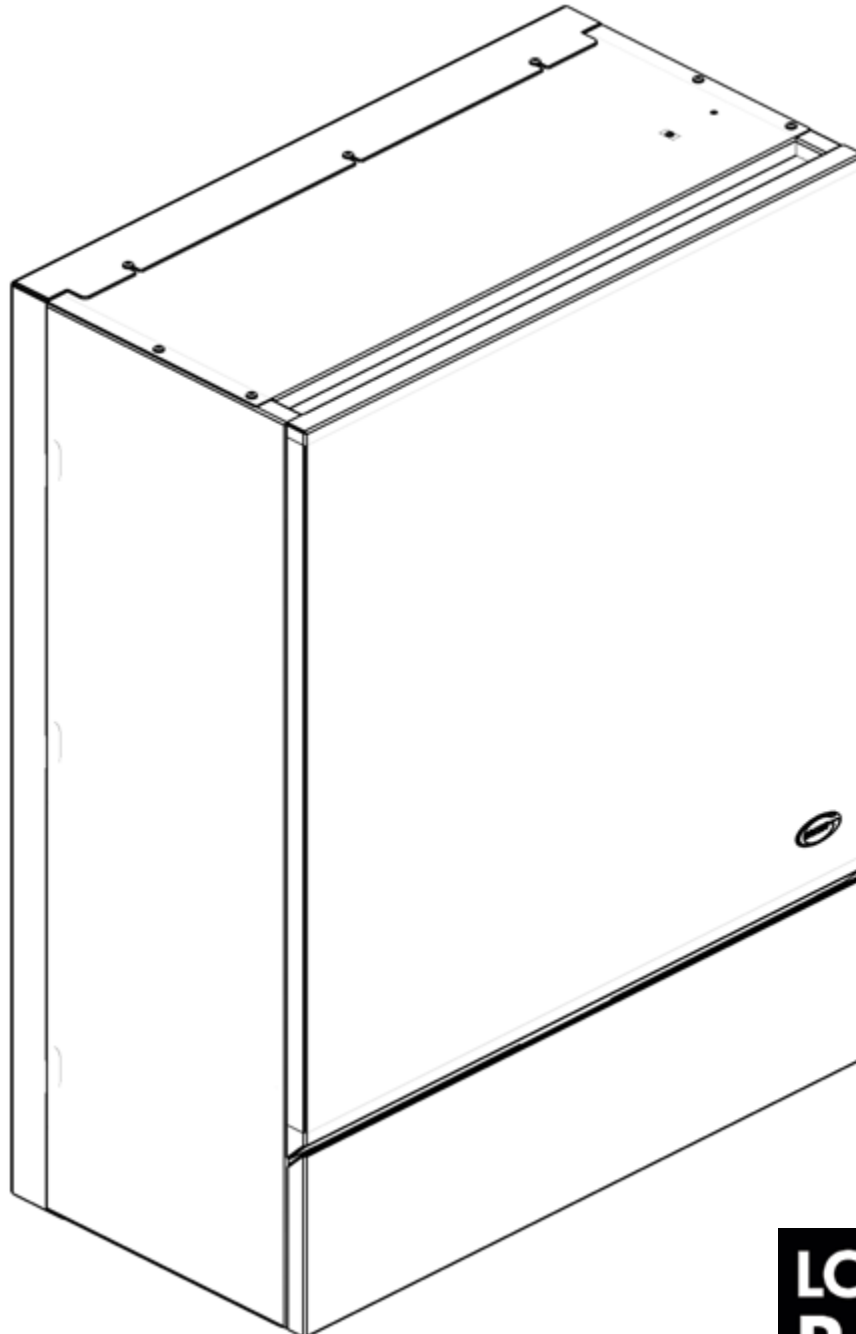

LOW NO_x
READY



IMPORTANT NOTE FOR INSTALLERS

These instructions are intended to guide installers on the installation, commissioning and servicing of the Grant Vortex oil boiler. After installing the boiler, leave these instructions with the user.

A user handbook is available to guide users in the operation of the oil boiler.

SPECIAL TEXT FORMATS

The following special text formats are used in these instructions for the purposes listed below:

! WARNING !

Warning of possible human injury as a consequence of not following the instructions in the warning.

! CAUTION !

Caution concerning likely damage to equipment or tools as a consequence of not following the instructions in the caution.

! NOTE !

Used for emphasis or information not directly concerned with the surrounding text but of importance to the reader.

PRODUCT CODES AND SERIAL NUMBERS COVERED

The serial numbers used on Grant oil boilers consist of a fifteen digit numerical code with the final three digits being the product identifier.

For example:

100000200218767

These instructions cover the following product codes and serial numbers:

Product code	Serial number identifier
VTXWH12/16	767
VTXWH16/21	769
VTXSWH12/16	768
VTXSWH16/21	770

SERVICING

The boiler should be serviced at least every twelve months and the details entered in the Service Log in the user handbook.

FUEL TYPE

All Grant Vortex boilers are suitable for use with Class C2 Kerosene. To use Bio-Kerosene (B30K), refer to the information below:

OPERATION ON BIO-FUEL

All Grant Vortex condensing boilers manufactured since May 2011 are suitable for operation on both standard Kerosene (Class C2 to BS 2869) and also bio-kerosene - up to a 30% blend (B30K).

All burner settings and nozzle sizes (as detailed in Section 2.2 of these instructions) are correct for both standard kerosene and bio-kerosene (B30K).

In order to operate this boiler on bio-kerosene, it will be necessary to take the following actions:

- Use a bio-kerosene (B30K) compatible flexible oil line in place of the oil line supplied with the boiler.
- Have the oil storage tank and oil supply line (including all pipework, sight gauges, filters, isolating valves, fire valves, de-aeration devices, etc.) checked for their compatibility with bio-kerosene (B30K).

Where necessary, some or all of these items may have to be replaced with a bio-kerosene compatible alternative.

- Check the suitability of the flue system with Grant UK.
- Use only bio-kerosene (B30K) that conforms to OPS24.

IMPORTANT:

Under no circumstances, should the boiler be used with bio-kerosene without the above actions being taken first.



GRANT ENGINEERING (UK) LIMITED

Hopton House, Hopton Industrial Estate, Devizes, Wiltshire, SN10 2EU

Tel: +44 (0)1380 736920 Fax: +44 (0)1380 736991

Email: info@grantuk.com www.grantuk.com

This manual is accurate at the date of printing but will be superseded and should be disregarded if specifications and/or appearances are changed in the interests of continued product improvement. However, no responsibility of any kind for any injury, death, loss, damage or delay however caused resulting from the use of this manual can be accepted by Grant Engineering (UK) Limited, the author or others involved in its publication.

All goods sold are subject to our official Conditions of Sale, a copy of which may be obtained on application.

© Grant Engineering (UK) Limited. No part of this manual may be reproduced by any means without prior written consent.

CONTENTS

1	INTRODUCTION	4	9	FLUE SYSTEM AND AIR SUPPLY	28
	1.1 How a condensing boiler operates	4		9.1 Air supply	28
	1.2 Boiler description	4		9.2 Conventional flue systems	28
	1.3 Flue options	4		9.3 Connecting a conventional flue	31
	1.4 Boiler components	5		9.4 Balanced flue systems	31
				9.5 Prepare the wall	35
				9.6 Flue clearances	36
2	TECHNICAL DATA	6	10	COMMISSIONING	38
	2.1 Boiler technical data	6		10.1 Before switching on	39
	2.2 Sealed system data	6		10.2 Burner settings:	39
	2.3 Burner settings	7		10.3 Switching on	40
	2.4 Flue gas analysis	7		10.4 Running the boiler	41
	2.5 Water connections	7		10.5 Balancing the system	41
	2.6 Boiler dimensions	8		10.6 Completion	41
3	OIL STORAGE AND SUPPLY SYSTEM	9	11	SERVICING	42
	3.1 Fuel supply	9		11.1 Checks before servicing	42
	3.2 Burner oil connection	11		11.2 Dismantling prior to servicing	42
4	INSTALLATION	13		11.3 Cleaning the boiler	43
	4.1 Introduction	13		11.4 Cleaning the burner	43
	4.2 Boiler location	13	12	FAULT FINDING	45
	4.3 Regulations	13	13	SPARE PARTS	48
	4.4 Heating system design considerations	13	14	DECLARATION OF CONFORMITY	50
	4.5 Pipework materials	14	15	HEALTH AND SAFETY INFORMATION	51
	4.6 Connections	14		15.1 Insulation materials	51
	4.7 Preparation for installation	14		15.2 Sealant and adhesive	51
	4.8 Dismantling the boiler	14		15.3 Kerosene and Gas Oil fuels	51
	4.9 Installing the boiler	16	16	END OF LIFE INFORMATION	52
	4.10 Before you commission	17	17	PRODUCT FICHE	53
	4.11 Completion	17	17	GUARANTEE	54
5	PIPE CONNECTIONS	18			
	5.1 Water connections	18			
	5.2 Water connections - system models	18			
6	CONDENSATE DISPOSAL	19			
	6.1 General requirements	19			
	6.2 Connections	19			
	6.3 Pipework	19			
	6.4 External pipework	19			
	6.5 Condensate soakaway	20			
	6.6 Condensate trap	20			
	6.7 Condensate disposal pipework	20			
	6.8 Inspection and cleaning of trap	20			
7	SEALED SYSTEMS	21			
	7.1 Sealed system requirements	21			
	7.2 Filling the sealed system	22			
	7.3 Venting the pump	22			
	7.3 Pressure relief (safety) valve operation	22			
8	ELECTRICAL	23			
	8.1 General	23			
	8.2 Connecting the power supply	23			
	8.3 Frost protection	23			
	8.4 Control system wiring diagrams	24			
	8.5 Boiler control panel wiring diagrams	26			

1 INTRODUCTION

1.1 HOW A CONDENSING BOILER OPERATES

During the combustion process, hydrogen and oxygen combine to produce heat and water vapour. The water vapour produced is in the form of superheated steam in the heat exchanger. This superheated steam contains sensible heat (available heat) and latent heat (heat locked up in the flue gas). A conventional boiler cannot recover any of the latent heat and this energy is lost to the atmosphere through the flue.

The Grant Vortex condensing boiler contains an extra heat exchanger which is designed to recover the latent heat normally lost by a conventional boiler. It does this by cooling the flue gases to below 90°C, thus extracting more sensible heat and some of the latent heat. This is achieved by cooling the flue gases to their dew point (approximately 55°C).

To ensure maximum efficiency, the boiler return temperature should be 55°C or less, this will enable the latent heat to be condensed out of the flue gases.

- The boiler will achieve net thermal efficiencies of 100%.

To achieve maximum performance from the Grant Vortex boiler, it is recommended that the heating system is designed so that a temperature differential of 20°C between the flow and return is maintained.

The Grant Vortex boiler will however still operate at extremely high efficiencies even when it is not in condensing mode and therefore is suitable for fitting to an existing heating system without alteration to the radiator sizes. The boiler is capable of a maximum flow temperature of 78°C.

1.2 BOILER DESCRIPTION

The Grant Vortex Eco Wall Hung range of automatic pressure jet oil boilers have been designed for use with a fully pumped central heating system with indirect domestic hot water cylinder.

They are not suitable for use with either a direct cylinder or a 'primatic' cylinder or gravity hot water.

The boilers are suitable for use on open vented or sealed central heating systems. System models are supplied with the necessary components factory fitted. Refer to Section 7.

All boilers are supplied with the control panel and burner factory fitted.

All the models in the current Grant Vortex Pro range of boilers are designed to comply with the maximum NOx emissions* under the Energy-related Products Directive (ErP).

* From the 26th September 2018, the maximum NOx emissions for all new oil fired boilers (up to and including 400kW for both new build and replacement boiler installations) is 120mg/kWh.

1.3 FLUE OPTIONS

The boilers can be connected to either a conventional flue system or a balanced flue system, as required.

1.3.1 FOR CONVENTIONAL FLUE APPLICATIONS

Where a chimney is to be lined - Grant recommends the use of the Grant 'Orange' flue system, specifically designed for the Vortex range of condensing boilers. Refer to Section 9.2 for further details.

Where a rigid conventional flue - either internal or external - is required, Grant recommends the use of the Grant 'Green' and 'Orange' flue system components. As no flue adaptor is supplied with the boiler it will be necessary to purchase the Grant CF adaptor kit in order to correctly connect this system to the boiler.

Flue adaptor kit (Grant product code: CFA15/70) is used for all models as they all use the 100 mm 'Green' and 'Orange' system components to construct a flue of maximum vertical height of 8 metres.

! NOTE !

The flue system materials and construction MUST be suitable for use with oil-fired condensing boilers. Failure to fit a suitable conventional flue may invalidate the guarantee on the boiler.

1.3.2 FOR BALANCED FLUE APPLICATIONS

The following flue kits are available from Grant UK. Refer to Section 9.4.

Yellow system

Standard low level concentric balanced flue - components available:

- Low level concentric balanced flue short
- Extensions 225 mm, 450 mm and 675 mm
- 90° extension elbow
- 45° extension elbow
- 45° elbow
- Plume diverter kits

Green system

Standard external high level/vertical flue starter kit (room sealed) - components available:

- External high level/vertical flue starter kit short (room sealed)
- Extensions 150 mm, 250 mm, 450 mm, 950 mm
- Adjustable extension 195 to 270 mm
- 45° elbow
- High level terminal
- Vertical terminal

White system

High level and vertical concentric balanced flue kit - components available:

- Extensions 225 mm, 450 mm, 950 mm
- Adjustable 275 to 450 mm
- Vertical concentric balanced flue kit
- Extensions 225 mm, 450 mm, 950 mm
- Adjustable extension 275 to 450 mm
- 45° elbow

Red system

A flexible vertical balanced flue system designed to be fitted inside an existing masonry chimney.

Consisting of three sections:

- Concentric white painted flue pipe connected to the boiler
- Vertical concentric flexible flue (flexible stainless steel flue liner inside a stainless steel air inlet liner)
- Terminal assembly for chimney top mounting

Flue extensions and 45° elbows from the White system may be used.

Fitting instructions for the Low level, High level and Vertical balanced flue systems are supplied with the kits.

1.4 BOILER COMPONENTS

All burners are pre-set for use with kerosene and are supplied ready to connect to a two pipe fuel supply system with a two flexible fuel lines and 3/8" to 1/4" BSP male adaptor supplied with the boiler.

The temperature of the water leaving the boiler to heat the radiators and hot water cylinder is user adjustable.

The boiler is fitted with an overheat thermostat (which allows it to be used on a sealed central heating system) which will automatically switch off the boiler if the heat exchanger exceeds a pre-set temperature of $110^{\circ}\text{C} \pm 3^{\circ}\text{C}$.

The control panel is fitted with an ON/OFF switch, boiler thermostat control knob and the manual reset button for the overheat thermostat.

To access the controls, open the lower front panel by pulling it down as shown in Figure 1-1.

Figure 1-2 shows the details of the control panel.

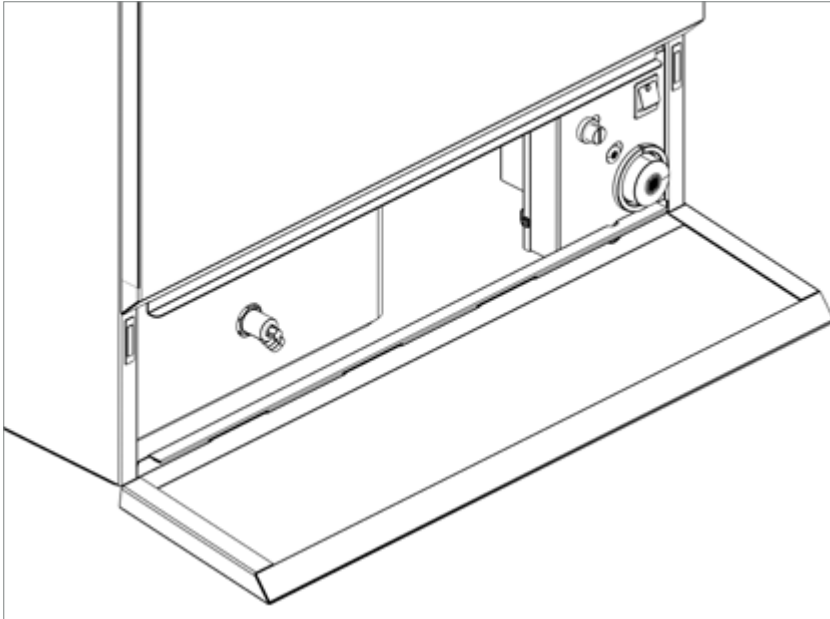

Figure 1-1: Boiler lower front panel in down position



Figure 1-2: Vortex Pro boiler control panel

2 TECHNICAL DATA

2.1 BOILER TECHNICAL DATA

Table 2-1: Boiler technical data

	Units	Internal Wall Hung		Internal System Wall Hung	
		12/16	16/21	12/16	16/21
Water content	litre	11	11	11	11
	gal	2.4	2.4	2.4	2.4
Weight - complete boiler (dry)	kg	91.1	91.1	98.0	98.0
	lb	200.8	200.8	216.1	216.1
Weight - boiler shell only (dry)*	kg	56.5	56.5	56.5	56.5
	lb	124.6	124.6	124.6	124.6
Maximum heat output (Kerosene)	kW	16.5	21.0	16.5	21.0
	Btu/h	56,300	71,700	56,300	71,700
Minimum flow rate ($\Delta T=10^{\circ}\text{C}$)	l/h	1,410	1,800	1,410	1,800
Minimum flow rate ($\Delta T=20^{\circ}\text{C}$)	l/h	730	900	730	900
Condensate connection		Accepts 21.5 mm \varnothing polypropylene overflow pipe			
Flue diameter (conventional)	mm	100			
Waterside resistance $\Delta T=10^{\circ}\text{C}$	mbar	28.5			
Waterside resistance $\Delta T=20^{\circ}\text{C}$	mbar	10.0			
Maximum static head	m	28			
Minimum circulating head	m	1			
Boiler thermostat range	$^{\circ}\text{C}$	65 to 78			
Limit (safety) thermostat shut off temperature	$^{\circ}\text{C}$	110 \pm 3			
Maximum casing temperature	$^{\circ}\text{C}$	Less than 50			
Electricity supply		~230 1ph 50Hz 5A fused			
Burner motor power	Watts	75			
Absorbed motor power	kW	0.155		0.143	
Starting current	Amps	2.7			
Running current	Amps	0.67			
Oil connection		1/4" BSP male (on end of flexible fuel hose)			
Conventional flue draught	mbar	Minimum: 0.087 - Maximum: 0.37			
	in wg	Minimum: 0.035 - Maximum: 0.15			
Maximum operating pressure - sealed/open system	bar	2.0			
Maximum operating pressure - pressure relief valve	bar	2.5			
Boiler type		ON/OFF			

* Weight of shell - without baffles and clean out door: 45.5kg

2.2 SEALED SYSTEM DATA

	Internal System 12/16 and 16/21
Heating system pressure (cold)	Minimum 0.5 bar Maximum 1.0 bar
Operating pressure of pressure relief valve	2.5 bar
Expansion vessel size (pre-charged at 1 bar)	8 litres
Maximum heating system volume (including boiler)*	85 litres
Cold water mains connection	15 mm compression (supplied)
Pressure relief valve discharge connection	15 mm compression (supplied)

* Based on vessel charge and system cold fill pressure of 0.5 bar

2.3 BURNER SETTINGS

Table 2-2: Burner settings

Boiler models (burner type)	Heat output		Nozzle	Oil pressure (bar)	Smoke No.	Burner head type	Distance between nozzle and burner head	Fuel flow rate (kg/h)	Flue gas temp. (°C)	CO ₂ (%)	Flue gas VFR ‡ (m ³ /hr)
	(kW)	(Btu/h)									
Internal and Internal System 12/16 (Ecoflam Max 1 LN Vortex WM 12-16 ERP)	12.7	40,900	0.40/80°S	7	0 - 1	EK 12-16	30.5	1.06	60 - 65	12.5	13.0
	14.0 *	47,800	0.40/80°EH	9	0 - 1	EK 12-16	31.5	1.17	65 - 69	12.5	15.0
	16.5	56,300	0.50/80°EH	8	0 - 1	EK 12-16	32.5	1.38	65 - 69	12.5	17.0
Internal and Internal System 16/21 (Ecoflam Max 1 LN Vortex WM 16-21 ERP)	16.5	56,300	0.50/80°EH	7	0 - 1	EK 16-21	29.5	1.38	65 - 69	12.5	17.0
	18.7 *	63,800	0.50/80°EH	10	0 - 1	EK 16-21	31.0	1.56	70 - 75	12.5	20.0
	21.0	71,700	0.60/80°EH	8	0 - 1	EK 16 - 21	31.0	1.76	75 - 79	12.5	23.0

Notes:

‡ Flue gas VFR: Flue gas volumetric flow rate

- The data given above is approximate only and is based on the boiler being used with a low level balanced flue.
- The above settings may have to be adjusted on site for the correct operation of the burner.
- Gas Oil is NOT suitable for use with Grant Vortex boiler range
- The flue gas temperatures given above are ± 10%.
- When commissioning, the air damper **must be** adjusted to obtain the correct CO₂ level.
- * Factory settings: 12/16 - 14kW, 16/21 - 18.7kW.
- The combustion door test point may be used for CO₂ and smoke readings only. Do not use this test point for temperature or efficiency readings.
- The installer must amend the boiler data label if the output is changed.

2.4 FLUE GAS ANALYSIS

To allow the boiler to be commissioned and serviced, the boiler is supplied with a combustion test point on the front cleaning door.

When this test point is used please note the following:

- The test point is for CO₂ and smoke readings only.
- The boiler efficiency and temperature must be taken from the flue test point on high level, vertical and conventional flue adaptors.
- Concentric low level flues do not contain a test point. The temperature and efficiency readings must be taken from the flue terminal.

2.5 WATER CONNECTIONS

Table 2-3: Water connections

Boiler model	Flow connection			Return connection		
	Size	Fitting	Supplied	Size	Fitting	Supplied
All models	22 mm	Push-fit Tectite	Fitted	22 mm	Push-fit Tectite	Fitted

2.6 BOILER DIMENSIONS

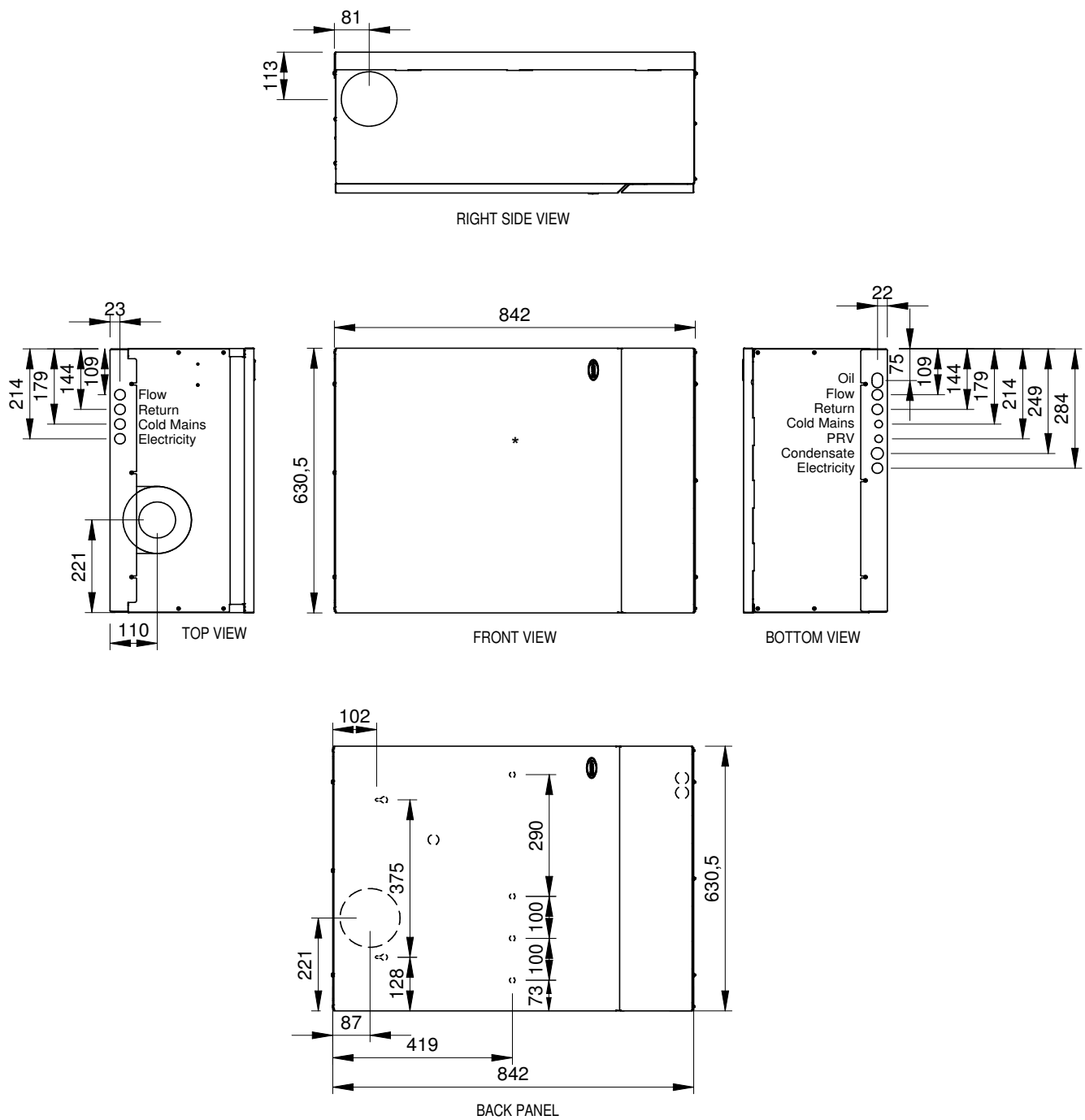

Figure 2-4: Vortex Eco Internal and Internal System 12/16 and 16/21

3 OIL STORAGE AND SUPPLY SYSTEM

3.1 FUEL SUPPLY

3.1.1 FUEL STORAGE

The tank should be positioned in accordance with the recommendations given in BS 5410-1 (Code of Practice for Oil Firing - Installations up to 45kW output capacity for space heating and hot water supply purposes). This gives details of the requirements for suitable oil tank construction, tank installation, tank bases, fire protection and secondary containment.

For installations of greater than 45kW output capacity, the tank should be installed accordance with BS 5410-2.

Oil storage tanks should comply with the following standards:

- Plastic tanks OFT T100
- Steel tanks OFT T200

! CAUTION !

A galvanised tank must not be used.

! NOTE !

Plastic tanks should be stood on a firm non-combustible base that adequately and uniformly supports the weight of the tank over its entire base area.

The tank capacity should be selected to suit the appliance rated output. Refer to BS5410-1 for guidance.

3.1.2 FUEL PIPES

Fuel supply pipes should be either copper or steel. Galvanised pipes or fittings should not be used.

Plastic oil supply pipe conforming to BS EN 14125 can be used for underground pipe runs, but must not be used above ground.

All soft copper pipe connections should preferably be made using flared fittings. If compression fittings are to be used, a suitable pipe insert must be fitted into the pipe end.

Soft soldered connections must NOT be used on oil supply pipework.

Fuel supply pipework should be of a suitable diameter, depending on the type of oil supply system being used. Refer to information given in sections 3.1.3, 3.1.4 or 3.1.5.

Run pipes as level as possible to prevent air being trapped. Take the most direct route possible from tank to burner whilst locating the pipe where it will be protected from damage.

Pipes should be supported to prevent sagging and sleeved where they pass through a wall.

A metal body fuel filter of no better than 70 µm (micron) must be fitted in the oil supply pipe close to the tank. This should be fitted with sufficient clearance around and below it to allow easy access for maintenance.

An isolating valve should also be fitted at the tank, before the filter, to allow the oil supply to be shut off for the filter to be serviced.

A second filter (15 µm for Kerosene) must be located closer to the burner to protect the burner pump and nozzle from contamination. Refer to Figures 3-1 to 3-3.

A remote sensing fire valve must be installed in the fuel supply line in accordance with BS540-1.

A fusible wheelhead type combined isolating/fire valve MUST NOT be used in place of a remote sensing fire valve.

The fire valve must be located outside; just before the oil line enters the building, with the fire valve sensor located above the burner.

A spring clip for mounting the sensor is provided with the boiler. This should be fixed with the screw provided, using the small hole in the front panel of the boiler.

The fire valve should be located after the second (15 micron) filter, i.e. between the filter and the point at which the oil line enters the building. Refer to Figures 3-1 to 3-3.

The fire valve must have an operating temperature of between 90 and 95°C to avoid unnecessary nuisance shut-offs to the oil supply.

Two flexible fuel hoses, adaptors and ¼" isolating valves are supplied loose with the boiler, to make the final connection to the burner with a two pipe or 'Tiger Loop' type de-aerator.

Metal braided flexible fuel hoses should be replaced ANNUALLY when the boiler is serviced.

Long life flexible fuel hoses should be inspected annually and replaced, if necessary, or after a maximum five years service life.

3.1.3 SINGLE PIPE (GRAVITY) SYSTEM - (REFER TO FIGURE 3-1)

Head (metres)	Maximum pipe run (m)		
	Ø 6 mm	Ø 8 mm	Ø 10 mm
0.5	19	60	100
1	21	66	100
1.5	23	72	100
2	25	79	100
2.5	27	85	100
3	29	91	100
3.5	31	98	100

If the storage tank outlet is at least 300 mm above the level of the level of the burner oil pump, a single pipe (gravity) system should be used.

The maximum height of the oil level above the burner oil pump when the tank is full, must not exceed four metres. If this height is exceeded, a pressure reducing valve must be fitted in the oil supply pipe between the tank and the burner oil pump.

The maximum length of pipe run from the tank to the burner is limited by the minimum head of oil (the height of the tank outlet above the burner oil pump).

3.1.4 TWO PIPE SYSTEM - (REFER TO FIGURE 3-2)

Head (metres)	Maximum pipe run (m)		
	Ø 6 mm	Ø 8 mm	Ø 10 mm
0.5	15	47	100
1	13	41	99
1.5	11	34	84
2	9	28	68
2.5	7	22	53
3	5	15	37
3.5	-	9	22

If the storage tank outlet is below the level of the burner oil pump, a two pipe (sub gravity) system can be used.

The return pipe should be at the same level as the tank outlet, between 75 to 100 mm above the base of the tank. The return pipe should be a sufficient distance from the tank outlet so as to prevent any sediment disturbed by the return entering the supply pipe from the tank.

A non-return valve should be fitted in the supply pipe, along with a fire valve and filters (refer to section 3.1.2 - fuel pipes). A non-return valve should also be fitted in the return pipe if the top of the tank is above the burner oil pump.

The maximum suction height (from the tank outlet to the level of the burner oil pump), must not exceed 3.5 metres.

The pump vacuum should not exceed 0.4 bar. Beyond this limit, gas is released from the oil.

For guidance on the installation of top outlet fuel tanks and suction oil supply pipe sizing, refer to OFTEC Technical Book 3: Storage and Supply, available for purchase from OFTEC.

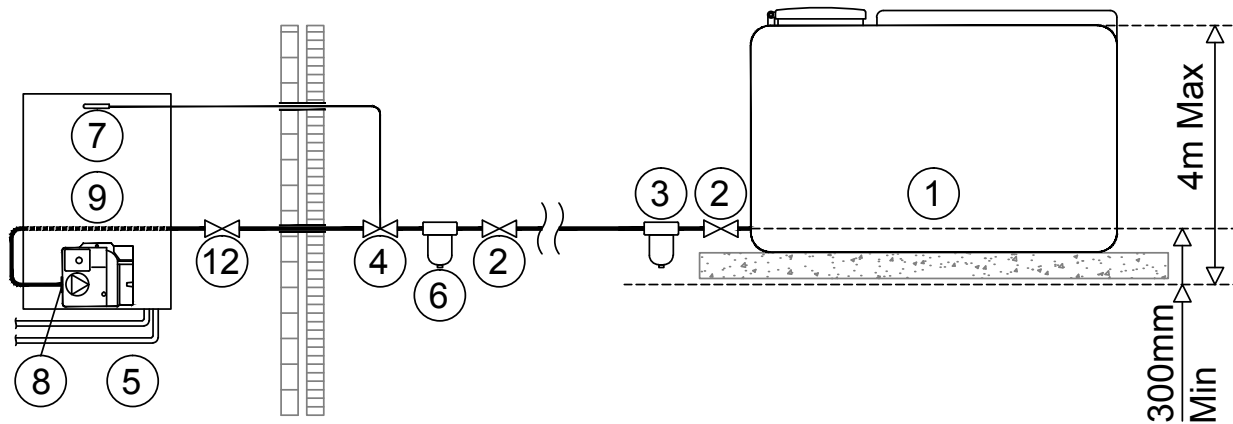

Figure 3-1: Single pipe (gravity) system

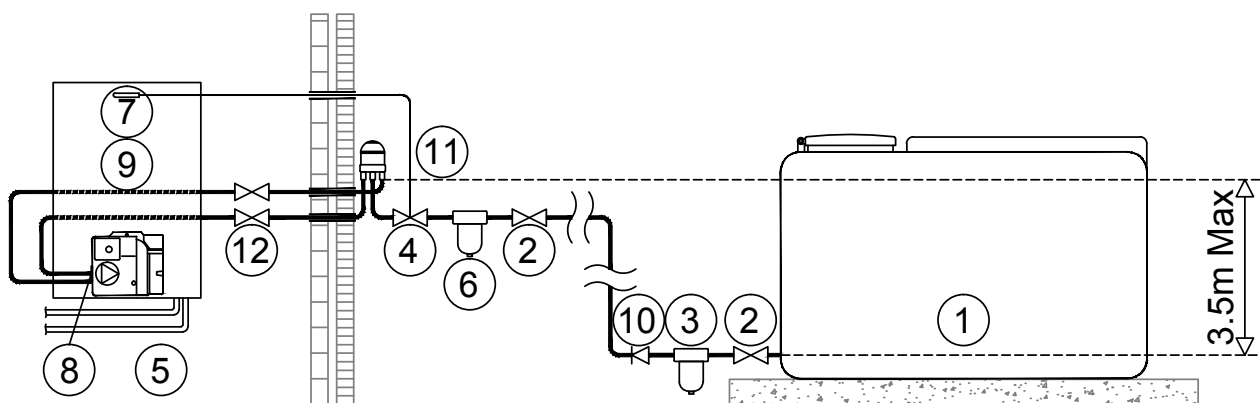

Figure 3-2: Two pipe system

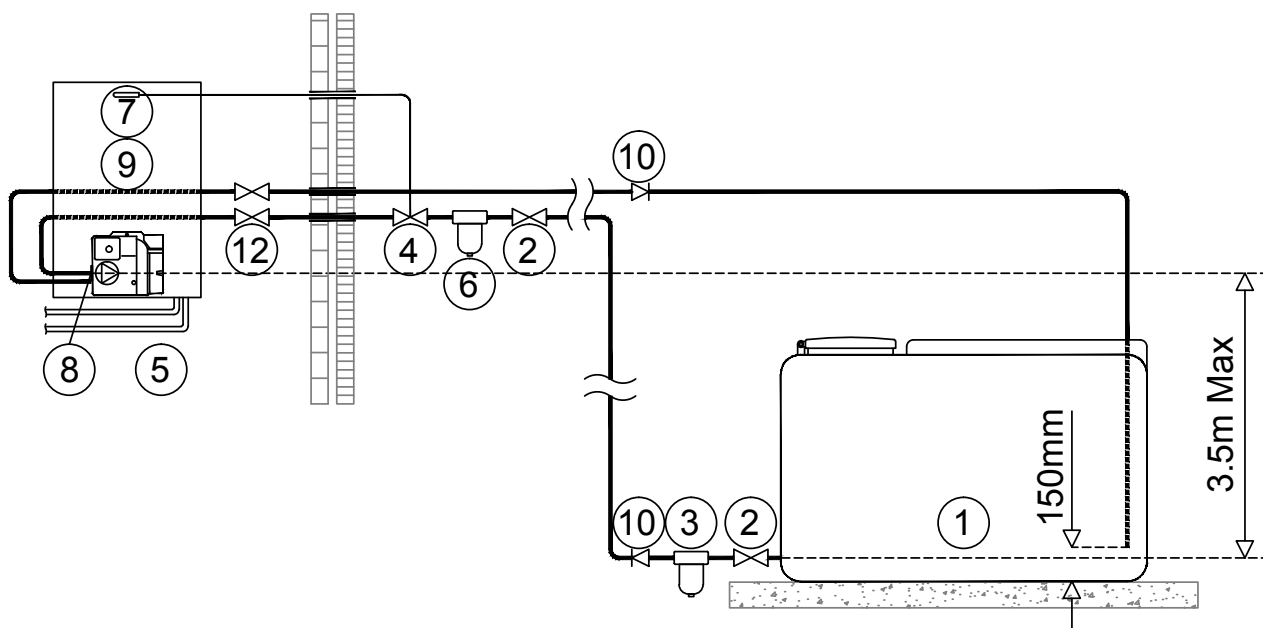

Figure 3-3: De-aeration device system

Key to oil supply diagrams

1	Oil tank	5	Heating flow and return	9	Burner
2	Isolating valve	6	Oil filter (15µm max. filtration size)	10	Non-return valve
3	Oil strainer	7	Fire valve sensor	11	De-aerator*
4	Fire valve to BS 5410	8	Oil pump	12	Appliance isolation valves

* Position of de-aeration device must be level with or above the oil pump

3.1.5 SINGLE PIPE (SUCTION) SYSTEM WITH DEAERATOR - (REFER TO FIGURE 3-3)

If the storage tank outlet is below the level of the burner oil pump, an alternative to the two pipe (sub gravity) system is the single pipe (suction) system using a deaerator, e.g. a 'Tiger Loop' device.

The deaerator creates a loop with the burner oil pump, with the oil being circulated through the pump out to the deaerator and back to the pump. Any air in the single pipe lift from the tank is removed from the oil, collected in the deaerator and then discharged to outside.

! WARNING !

To prevent any fuel vapour being discharged within the building, the deaerator must be fitted outside, in accordance with BS 5410-1, unless it is specifically designed to be installed inside.

The de-aerator must be mounted vertically at the same level as (or above) the burner oil pump. Refer to Figure 3-3.

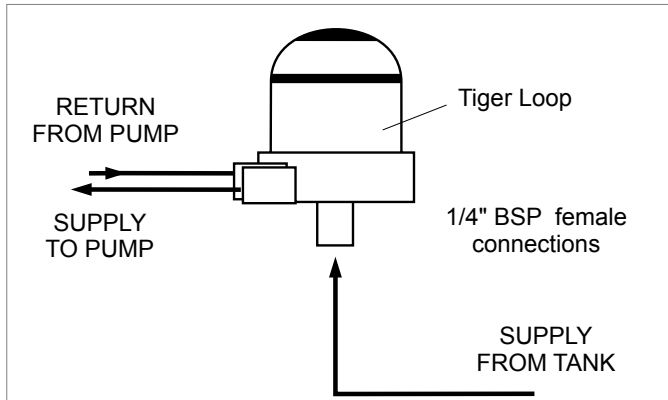

Figure 3-4: Tiger loop de-aeration device

An external deaerator must not be fitted within 500 mm of a flue terminal.

Always follow the manufacturers installation instructions supplied with the deaerator.

3.2 BURNER OIL CONNECTION

The burner fuel pump is supplied factory set for use with a two pipe oil supply system.

For ease of access to the burner oil pump connections, the burner should be removed from the boiler as follows:

1. Unscrew and remove the single burner fixing nut from the stud on the burner flange (at the top of the burner) using a 13 mm spanner. Retain the fixing nut for re-fitting the burner.
2. Rotate the burner clockwise and carefully withdraw the burner from the boiler. Refer to Figure 3-5.

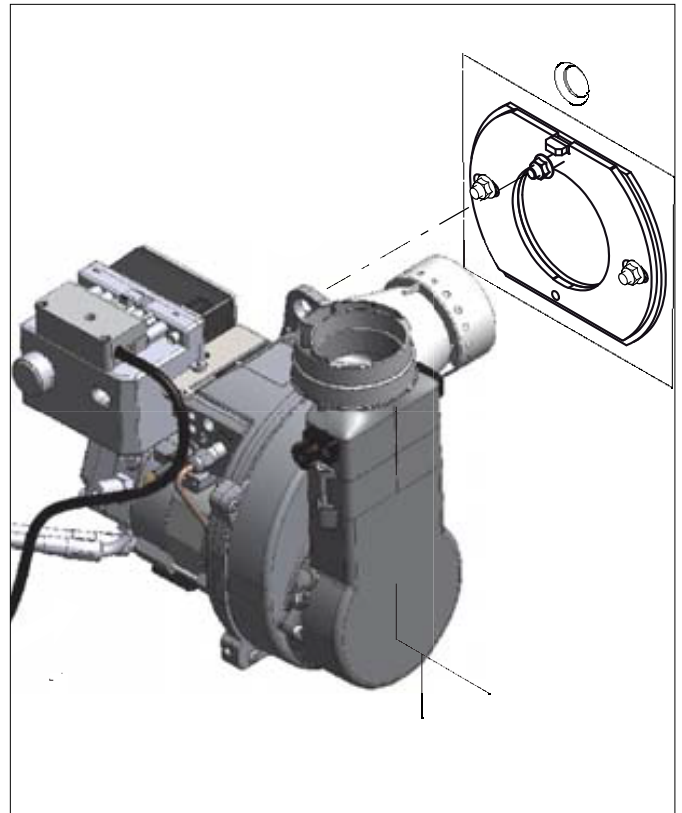

Figure 3-5: Burner removal

SINGLE PIPE (GRAVITY) SYSTEM

For use on a single pipe system, it is necessary to fit the 'horseshoe' washer into the tapping in the pump. Refer to Figure 3-6.

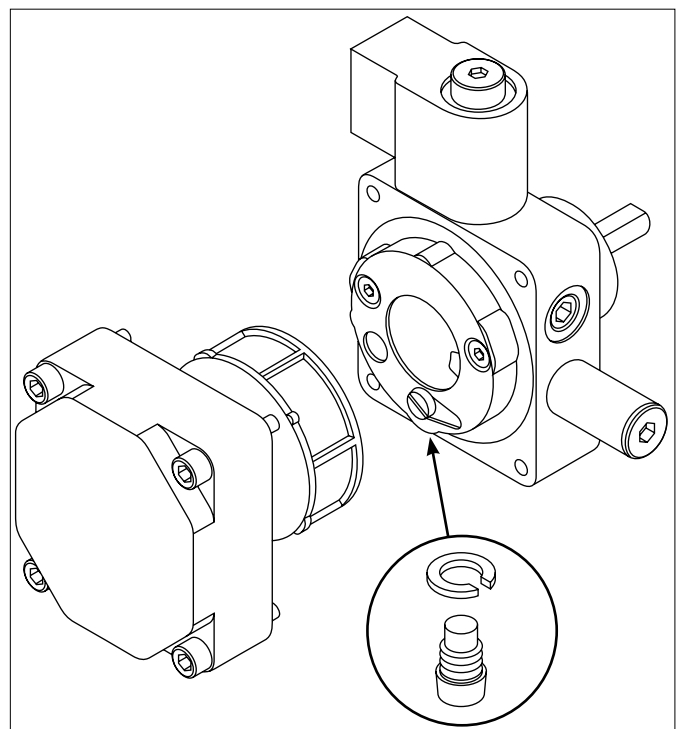

Figure 3-6: Fitting/location of 'horseshoe' washer

This page is intentionally left blank.

4 INSTALLATION

4.1 INTRODUCTION

The boiler is supplied already fully assembled in a carton which is carefully packed with packing materials. As the boiler is wall mounted all of the content of the boiler casing must be removed with the packaging before installation can begin, to give access to the rear fixing panel.

The installation procedure therefore begins with unpacking and dismantling of the packed boiler.

4.2 BOILER LOCATION

The boiler should be fixed to a wall that is firm, flat and vertical. It does not require any special base provisions as the temperature of the boiler casing is less than 50°C.

Sufficient clearance must be allowed at the front of and below the boiler to remove the burner and baffles for servicing.

4.3 REGULATIONS

! NOTE !

Failure to install and commission appliances correctly may invalidate the boiler guarantee.

Installation of a Grant Vortex boiler must be in accordance with the following recommendations:

- Building Regulations for England and Wales, or the Building Standards for Scotland, as appropriate.
- Any relevant local Byelaws which you must check with the local authority for the area concerned.
- The Water Supply (Water Fittings) Regulations 1999 or the Water Supply (Fittings) (Scotland) Byelaws 2014, as appropriate.
- Applicable Control of Pollution Regulations.
- The following OFTEC requirements:
 - OFS T100 Polythene oil storage tanks for distillate fuels.
 - OFS T200 Fuel oil storage tanks and tank bunds for use with distillate fuels, lubrication oils and waste oils.

Further information may be obtained from the OFTEC Technical Book 3 (Installation requirements for oil storage tanks) and OFTEC Technical Book 4 (Installation requirements for oil fired boilers).

The installation should also be in accordance with the latest edition of the following British Standard Codes of Practice (and any relevant amendments):

- BS 5410-1 (Code of practice for oil firing. Installations up to 45 kW output capacity for space heating and hot water supply purposes)
- BS EN 12828 (Heating systems in buildings. Design for water-based heating systems)
- BS EN 12831-1 (Energy performance of buildings. Method for calculation of the design heat load)
- BS EN 14336 (Heating systems in buildings. Installation and commissioning of water-based heating systems)
- BS 7593 (Code of Practice for treatment of water in domestic hot water central heating systems)
- BS 7671 (Requirements for Electrical installations, IET Wiring Regulations)
- BS 7291 (Thermoplastics pipe and fitting systems for hot and cold water for domestic purposes and heating installations in buildings. General requirements)
- BS 7074-1 (Application, selection and installation of expansion vessels and ancillary equipment for sealed water systems. Code of practice for domestic heating and hot water supply)
- BS 2869 (Fuel oils for agricultural, domestic and industrial engines and boilers. Specification)

4.4 HEATING SYSTEM DESIGN CONSIDERATIONS

! WARNING !

Before starting any work on the boiler or fuel supply, please read the Health and Safety information given in Section 15.

To achieve the maximum efficiency possible from the Grant Vortex boiler, the heating system should be designed to the following parameters:

RADIATORS:

- Flow temperature 70°C
- Return temperature 50°C
- Differential 20°C

Size radiators with a mean water temperature of 60°C.

Design system controls with programmable room thermostats or use weather compensating controls to maintain return temperatures below 55°C.

! NOTE !

The boiler should not be allowed to operate with return temperatures of less than 40°C when the system is up to temperature.

The use of a pipe thermostat is recommended to control the return temperature when using weather compensating controls.

UNDERFLOOR:

- Flow temperature 50°C
- Return temperature 40°C
- Differential 10°C

In underfloor systems, it is essential that the return temperature must be maintained at or above 40°C to prevent internal corrosion of the boiler water jacket.

Refer to Section 2.5 for the size and type of the connections and Section 5 for the position of the connections.

OPEN VENTED SYSTEMS:

! NOTE !

The presence of 'pumping over' in an open vented heating system connected to the Grant Vortex boiler will invalidate the product guarantee.

Open vented systems must be correctly designed and installed. The open safety vent pipe must be positioned to prevent 'pumping over' (i.e. the discharge of water from the open safety vent pipe into the feed and expansion cistern under the pressure created by the circulator). For detailed information on the correct design of open vented heating systems, and the correct location of the open safety vent pipe, refer to the CIBSE Domestic Heating Design Guide and OFTEC Technical Book 4 (Installation).

4.5 PIPEWORK MATERIALS

Grant Vortex boilers are compatible with both copper and plastic pipe. Where plastic pipe is used it must be of the oxygen barrier type and be the correct class (to BS 7291-1) for the application concerned.

On either sealed or open-vented systems; where plastic pipe is used a minimum of ONE metre of copper pipe (or as per pipe manufacturers instructions) MUST be connected between both the boiler flow and return connections and the plastic pipe.

! NOTE !

Do not connect plastic pipe directly to the boiler.

Grant UK does not accept any responsibility for any damage, however caused, to plastic piping or fittings.

SEALED SYSTEMS

If plastic pipe is to be used, the installer must check with the plastic pipe manufacturer that the pipe to be used is suitable for the temperature and pressures concerned.

Plastic pipe must be Class S to BS 7291-1.

! WARNING !

When plastic pipe is used, the system MUST incorporate a low level pressure switch to shut off power to the boiler if the system pressure drops below 0.2 bar. A suitable low pressure switch kit is available to purchase from Grant UK (product code: MPCBS62).

UNDERFLOOR PIPEWORK

Plastic pipe may be used on underfloor floor systems where the plastic pipe is fitted after the thermostatic mixing valve. Copper tube must be used for at least the first metre of flow and return primary pipework between the boiler and the underfloor mixing/blending valves.

4.6 CONNECTIONS

4.6.1 FLOW AND RETURN CONNECTIONS

Refer to Section 5.

4.6.2 CONDENSATE CONNECTION

Grant Vortex Pro boilers are supplied with a factory-fitted condensate trap to provide the required 75 mm water seal in the condensate discharge pipe from the boiler.

Refer to Section 6 for details of the condensate disposal pipework.

4.6.3 DRAIN COCK

A drain cock is fitted at the bottom on the front of the boiler to allow the heating system to be drained.

4.7 PREPARATION FOR INSTALLATION

The following procedure must be performed before you can begin dismantling the boiler for installation:

1. With the boiler on the pallet, open the carton and remove all packing materials and the carton from the boiler.
2. Lift open lower front panel, slide panel to left or right and detach from the boiler.

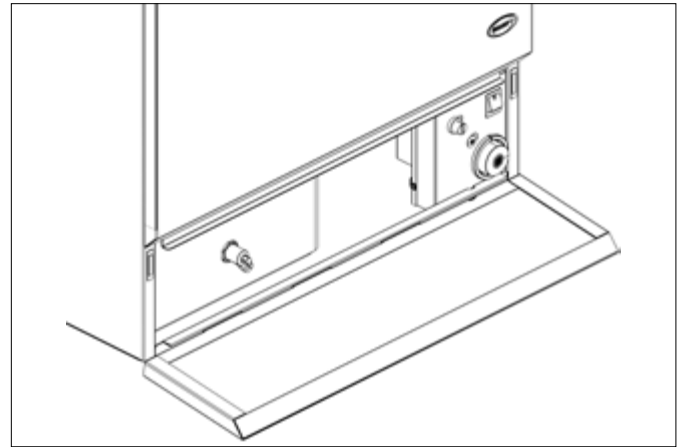

Figure 4-1: Boiler front panel open

3. Remove upper front panel. Pull bottom edge of panel sharply upwards to disengage retaining clips and lift off from boiler
4. Remove internal packaging from within boiler casing.
5. Remove filling loop and flexible oil hose packs from within boiler.

4.8 DISMANTLING THE BOILER

Dismantle the boiler as follows, keeping all components, screws and washers for re-assembly:

1. Slacken off hose clip on burner air inlet and remove snorkel tube from boiler.
2. Unscrew earth wire from underside of top casing panel.
3. Slacken the three screws at rear of top casing panel. Remove screws securing top panel to side panels. Pull top front corner of side casing panel on both sides by 10 mm outwards to disengage tabs on top casing panel. Pull top panel forwards to remove from boiler.
4. Disconnect plug from burner control box.
5. System model only – Disconnect plug from pump.
6. Unscrew inlet connection to condensate trap and remove trap from boiler.
7. Remove retaining clip and thermostat phials from their pocket (in right side of heat exchanger – below return connection).

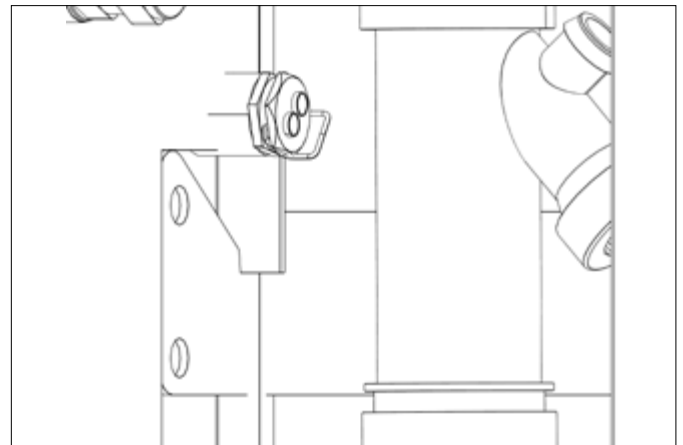

Figure 4-2: Removing thermostat phials

8. System model only - Unscrew and disconnect pressure gauge pipe from PRV body.
9. Slacken control panel retaining screws and remove control panel from boiler.

10. Remove the two screws securing right hand side panel to bottom panel. Remove right hand side panel from boiler by lifting upwards to disengage tabs.
11. Repeat procedure to remove left hand side panel from boiler.
12. Slacken the three screws at rear of bottom casing panel and remove bottom panel from boiler.
13. System model only - Unscrew upper pump union and remove pump, complete with flow pipe, from boiler.



Figure 4-3: Removing flow and return pipe

14. Non-system model – Unscrew compression connection on boiler shell and remove flow pipe from boiler.
15. Unscrew top right compression connection and remove return pipe from boiler.
16. Using a 13mm socket, slacken burner retaining nut (on top of burner). Rotate burner clockwise (towards rear of boiler), pull burner to the right until burner head is clear of mounting flange and remove burner from boiler.
17. Using 13mm spanner, unscrew the two clean-out door retaining nuts and remove door from front of boiler shell.

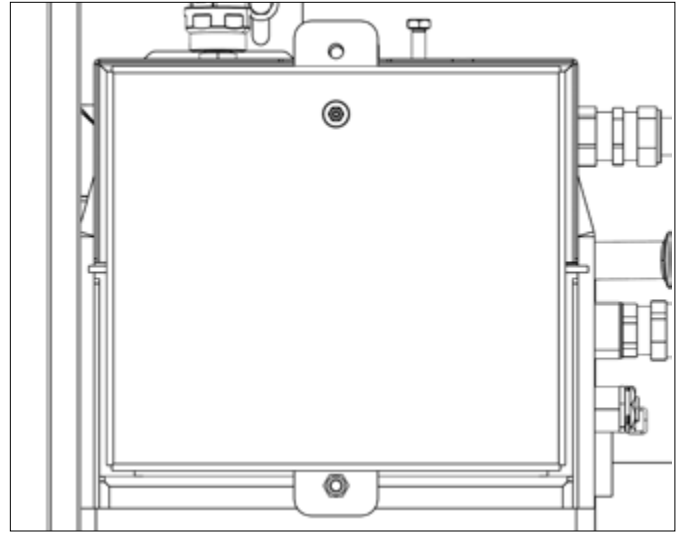

Figure 4-4: Removing clean-out door

18. Remove baffles from boiler shell.

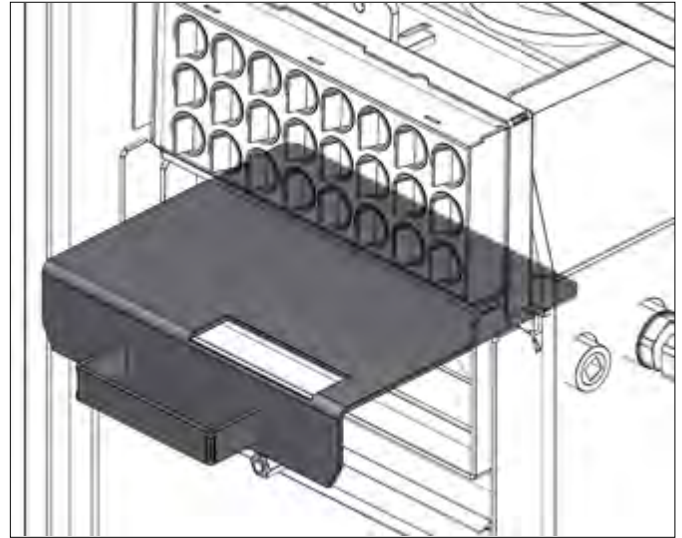

Figure 4-5: Removing baffles from boiler shell

19. Undo retaining screw and nut and remove transit bracket from top of boiler shell.
20. Push boiler shell upwards to disengage it from mounting bracket on back panel of boiler taking care not to damage the insulation on the side of shell.
21. Lift boiler shell away from back panel and stand it upright on the four feet.
22. Unscrew and remove the two transit screws securing mounting bracket and back panel to pallet.

4.9 INSTALLING THE BOILER

You are now ready to install the boiler.

The procedure is as follows:

1. If a back outlet flue system is to be used, remove the large circular flue knock-out from back panel. If the rear outlet PRV discharge is to be used, remove the knock-out from the back panel (as shown in the figure below).

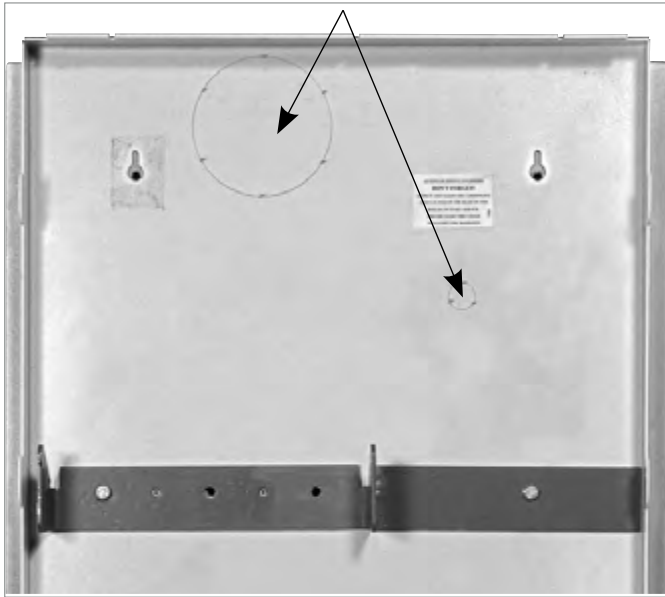

Figure 4-6: Installing the back panel

2. Locate and hold the back panel in the required position on the wall. Check it is level using a spirit level on the top flange. Mark position of the holes for the two keyhole slots. Remove the back panel from the wall.
3. Drill and fit wall fixing plugs (supplied) in the two holes. Fit the two screws (supplied) and mount the back panel on the wall using the two keyhole slots. Check again that the back panel is level before proceeding.
4. Mark the position of the four mounting bracket fixings on to the wall from the back panel. Also mark the positions of the flow and return pipes, the cold mains (for filling loop), the electrical power supply, and the condensate discharge pipe.
5. If using a back outlet flue and/or rear PRV outlet is to be used, also mark these holes on to the wall.

! NOTE !

If side outlet flue is to be used (to either left or right) then mark position as it may be necessary to cut flue hole BEFORE installing boiler on to wall.

6. Remove the back panel from the wall. Drill the holes for the mounting bracket fixings and fit the wall plugs provided. Drill all other necessary holes. If required, core drill the wall for a back outlet flue and drill a hole for the PRV discharge pipe. Re-mount the back panel on the two keyholes slots.
7. Locate the mounting bracket on to the back panel, aligning the four holes in the bracket with those in the back panel. Ensure that the mounting 'hooks' are pointing upwards and secure using the fixings supplied with the boiler.
8. Check the mounting bracket is level.

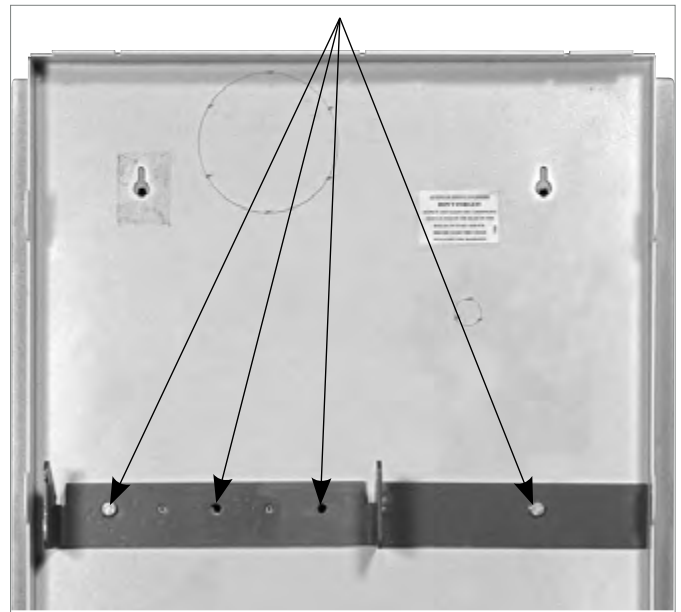

Figure 4-7: Fixing the back panel

9. Unscrew and remove flue fixing screw from flue outlet.
10. Lift the boiler shell and hang it on the mounting bracket – ensuring that the mounting plates on either side of the shell are fully located in the vertical slot of both mounting hooks.
11. Re-fit the return pipe to top right hand connection on boiler shell. Pass return pipe from system through hole in back panel (either at top or bottom of panel, as required) and connect to boiler return pipe.



Figure 4-8: Re-fitting flow and return pipe

12. System model only - Re-fit pump complete with flow pipe to upper pump union on boiler shell. Ensure that rubber pump union washer is fitted. Pass flow pipe from system through hole in back panel (either at top or bottom of panel, as required) and connect to boiler flow pipe.
13. Non-system model – Re-fit flow pipe to compression connection on boiler shell. Pass flow pipe from system through hole in back panel (either at top or bottom of panel, as required) and connect to boiler flow pipe.

! NOTE !

It is recommended that the system flow and return pipes are connected to the boiler at this point in the installation. Two 22mm isolating valves are supplied for use with sealed system models only. These must not be used on an open vented system. These boiler isolating valves should be located adjacent to the boiler in a convenient position.

14. Re-fit burner. First remove burner securing nut, locate burner head into hole in burner flange/boiler shell and locate mounting screw through hole on top of burner. Re-fit nut and tighten to secure burner in place. Connect flexible oil lines

from oil supply pipework to burner. It is recommended that the copper oil lines are installed at this stage while the side panels are not in place.

15. Re-fit baffles into boiler shell – ensuring they are in the correct order (check marking on each baffle) as shown below.

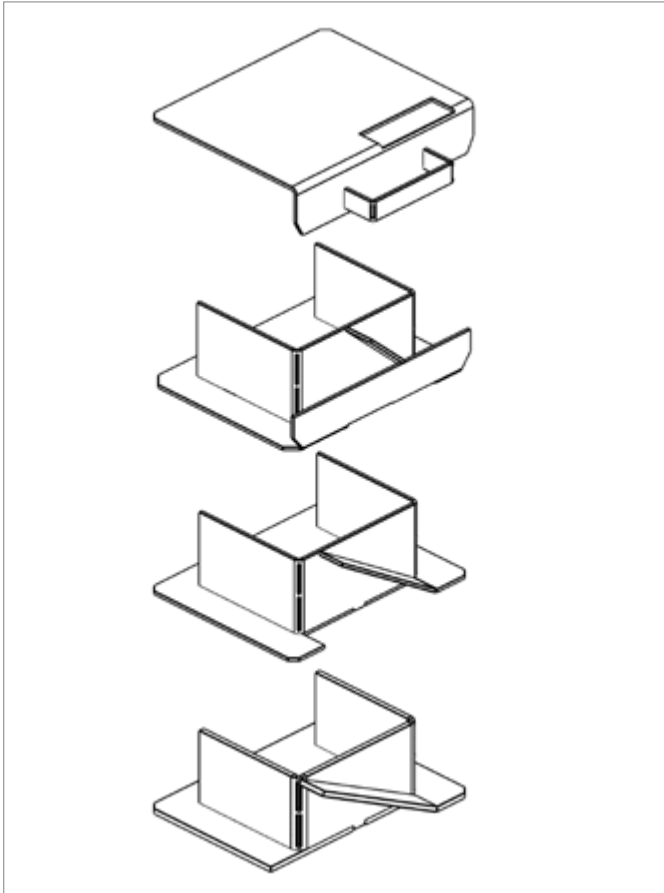

Figure 4-9: Re-fitting baffles into boiler shell

16. Locate clean-out door onto the two studs, re-fit nuts and tighten to secure door in place.
17. If side outlet flue system is to be used, remove flue 'knock-out' from either the left or right side casing panel, as required.
18. Re-fit left hand casing panel locating tabs on rear edge of panel into slots in back panel. Firmly push side panel downwards to fully engage tabs.
19. Repeat process to re-fit right hand casing panel.
20. Pass flue through hole in side panel and secure.
21. Re-fit bottom casing panel and secure in place with screws (with washers).
22. If top outlet flue system is to be used, remove the flue 'knock-out' in both the top casing panel and the top flange of the back panel.
Fit the boiler connector (supplied in the flue kit) to the top of the boiler shell, ensuring it is firmly connected and making a seal on the neoprene gasket.
Refer to flue installation instructions for further details.
23. Re-fit top casing panel and secure in place with screws (with washers). Ensure that the ends of the front flange fit into the slots in the top front of side panels.
24. System model only - Re-fit expansion vessel onto bracket inside right hand side panel and reconnect expansion vessel hose to connection on front right hand side of boiler shell. Ensure rubber sealing washer is fitted.
25. Re-fit control panel – locating fixing screws into slots in front flange of bottom panel. Tighten screws to secure.
26. Re-locate thermostat bulbs in pocket at rear right hand side of boiler shell.
27. System model only - Re-connect pressure gauge to PRV and tighten.
28. Re-connect burner plug.
29. System model only - Re-connect pump plug.
30. Re-fit condensate trap. Connect condensate discharge pipe

to outlet of trap.

31. Re-fit snorkel tube to air inlet connection on burner. Tighten hose clip to secure.
32. If balanced flue system is fitted, connect other end of snorkel tube to air inlet spigot of flue system.
33. If a conventional flue system is used, locate other end of snorkel in top of boiler, ensuring that inlet to tube is not restricted.
34. Fit flue system to boiler – refer to flue system installation instructions.
35. Re-fit upper front casing panel – hook top edge over front edge of top panel, locate pins into spring retaining clip on each side panel and push firmly home to secure.
36. Re-fit lower front panel – with the panel at 45° to vertical, locate the tabs into the horizontal slots in front of bottom panel. Slide to either left or right and lift into closed position against magnetic catches.

4.10 BEFORE YOU COMMISSION

To avoid the danger of dirt and foreign matter entering the boiler the complete heating system should be thoroughly flushed out – both before the boiler is connected and then again after the system has been heated and is still hot. This is especially important where the boiler is to be installed on an older system.

For optimum performance after installation, the boiler and the associated heating system must be flushed in accordance with the guidelines given in BS 7593 (Treatment of water in domestic hot water central heating systems). This must involve the use of a proprietary cleaner, such as Sentinel X300 (new systems), Sentinel X400 (existing systems), or Fernox Restorer.

After cleaning, it is vitally important that all traces of the cleaner are thoroughly flushed from the system.

For long term protection against corrosion and scale, after cleaning/flushing a suitable inhibitor should be added to the system water, such as Sentinel X100 or Fernox MB-1, in accordance with the manufacturers' instructions.

Failure to follow the above will invalidate the guarantee.

If the boiler is installed in a garage or out house, in order to provide further protection should there be a power failure in cold weather, a combined anti-freeze and corrosion inhibitor can be used such as Sentinel X500 or Fernox Alpha-11. Follow the manufacturers' instructions supplied to achieve the level of anti-freeze protection required.

For details of the Sentinel Products visit www.sentinel-solutions.net and for Fernox products visit www.fernox.com.

Grant UK strongly recommends that a Grant Mag One in-line magnetic filter/s (or equivalent*) is fitted in the heating system pipework. This should be installed and regularly serviced in accordance with the filter manufacturer's instructions.

* As measured by gauss. The MagOne magnetic filter has a gauss value of 12000.

4.11 COMPLETION

Following installation of the boiler, instruct the user in the operation of the boiler, the boiler controls, the heating controls and the safety devices.

Please ensure that the OFTEC CD/10 installation completion report (provided with the boiler) is completed in full, leaving the top copy with the user and retain the carbon copy for your own records.

Ensure that the User Handbook (supplied with the boiler) is handed over to the user.

5 PIPE CONNECTIONS

5.1 WATER CONNECTIONS

FLOW AND RETURN CONNECTIONS - ALL MODELS

On all models a 22mm push-fit connection is provided for both the heating flow and return connections.

Holes are provided in the top and bottom casing panels to route the pipework as required.

! CAUTION !

All pipes to be fitted into the push-fit connectors provided should be cut using a pipe slicer or pipe cutter - to leave the pipe ends with a slight radius and free from any burrs or sharp edges. Pipes to be used with these fittings should not be cut square using a hacksaw.

5.2 WATER CONNECTIONS - SYSTEM MODELS

A 15 mm discharge pipe must be connected to the safety valve outlet connection. The pipework between the safety valve and the boiler must be unrestricted, that is, no valves. The discharge pipe should be run to the outside of the building and terminate so that it cannot cause injury to persons or property.

A 15 mm double check valve ballofix type valve is provided on the flexible filling loop hose for connection of the cold mains supply to the heating system.

The cold mains supply should terminate inside the boiler casing.

A drain cock is fitted at the bottom on the front of the boiler to allow the heating system to be drained.

The expansion vessel is connected via a flexible hose to allow it to be moved to gain access to the burner and condensate trap for servicing.

When replacing the vessel, care should be taken to ensure that the flexible connecting hose is not twisted.



Figure 5-1: Non system boiler flow and return connections



Figure 5-2: System boiler flow and return connections

6 CONDENSATE DISPOSAL

6.1 GENERAL REQUIREMENTS

When in condensing mode the Grant Vortex boilers produce condensate from the water vapour in the flue gases.

This condensate is moderately acidic with a pH value of around 3.27 (similar to orange juice).

Provision must be made for the safe and effective disposal of this condensate.

Condensate can be disposed of using one of the following methods of connection:

Internal connection (preferred option)

- into an internal domestic waste system (from kitchen sink, washing machine, etc.)
- directly into the soil stack

External connection

- into an external soil stack
- into an external drain or gully
- into a rainwater hopper (that is part of a combined system where sewer carries both rainwater and foul water)
- purpose made soakaway

All condensate disposal pipes **must** be fitted with a trap - whether they are connected internally or externally to a domestic waste system/soil stack or run externally to a gully, hopper or soakaway.

6.2 CONNECTIONS

Connections into a rainwater hopper, external drain or gully should be terminated inside the hopper/drain/gully below the grid level but above the water level.

! CAUTION !

Condensate disposal pipes must not be connected directly into rainwater downpipes or to waste/soil systems connected to septic tanks.

Condensate should not be discharged into 'grey water' systems that re-use water used in the home (not including water from toilets).

It should be noted that connection of a condensate pipe to the drain may be subject to local Building Control requirements.

6.3 PIPEWORK

Condensate disposal pipework must be plastic (plastic waste or overflow pipe is suitable).

! NOTE !

Copper or steel pipe is NOT suitable and MUST NOT be used.

Condensate disposal pipes should have a minimum 'nominal' diameter of 22 mm (¾") - e.g. use 21.5 mm OD polypropylene overflow pipe.

Condensate disposal pipes must be fitted with a fall (away from the boiler) of at least 2.5° (~45 mm fall per metre run).

! NOTE !

Where it is not possible for the pipe to fall towards the point of discharge - either internally into a waste system or externally to a gully (e.g. for boilers installed in a basement), it will be necessary to use a condensate pump.

Condensate disposal pipes should be kept as short as possible and the number of bends kept to a minimum.

Pipes should be adequately fixed to prevent sagging, i.e. at no more than 0.5 metre intervals.

6.4 EXTERNAL PIPEWORK

Ideally, external pipework, or pipework in unheated areas, should be avoided. If unavoidable, external pipework should be kept as short as possible (less than 3 metres) and 32 mm waste pipe used to minimise the risk of ice blocking the pipe in freezing conditions.

The number of bends, fittings and joints on external pipes should be kept to a minimum to reduce the risk of trapping condensate.

! NOTE !

For boilers installed in an unheated area such as a loft, basement, outhouse or garage, all condensate pipework should be as 'external'.

The pipework should be insulated using suitable waterproof and weather resistant insulation.

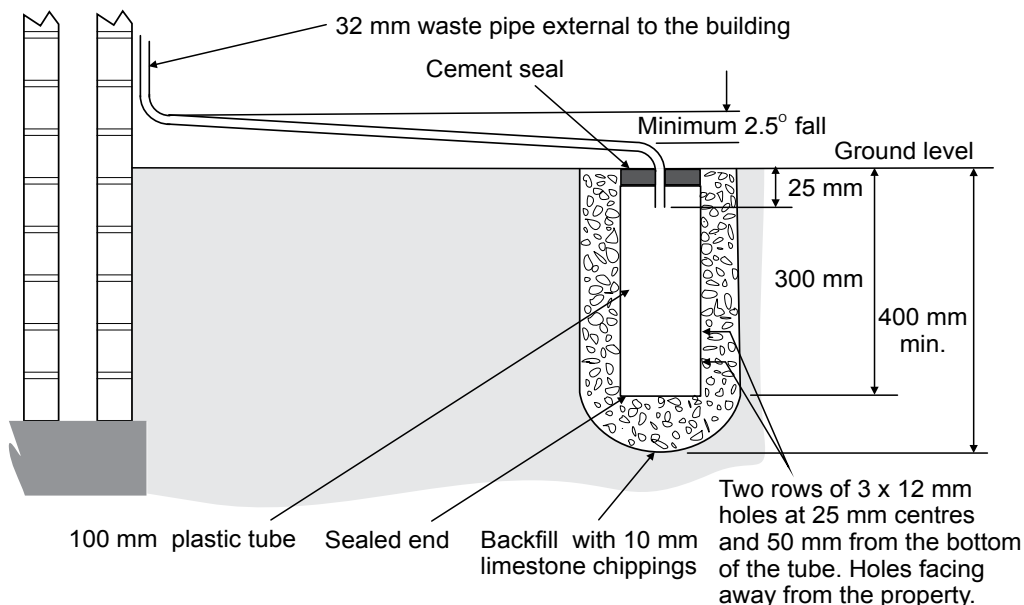

Figure 6-1: Purpose made condensate soakaway

6.5 CONDENSATE SOAKAWAY

To keep external pipework to a minimum, locate the soakaway as close as possible to the boiler but ensure it is at least 500 mm from building foundations and away from other services, e.g. gas, electricity, etc.

The condensate pipe may be run above or below ground level and can enter either the top or side of the soakaway tube. Refer to Figure 6-1.

Ensure that the drainage holes in the soakaway tube face away from the building.

Backfill both the soakaway tube, and the hole around it, with 10 mm limestone chippings.

Only use a soakaway where the soil is porous and drains easily. Do not use in clay soils or where the soil is poorly drained.

! CAUTION !

Any damage due to condensate backing up into the boiler due to a high water table, in the case of a soakaway, or flooded drains when the condensate disposal is via a gully or soil stack, is not covered by the Grant product guarantee.

6.6 CONDENSATE TRAP

Grant Vortex boilers are supplied with a condensate trap to provide the required 75 mm water seal in the condensate discharge pipe from the boiler.

The condensate trap is factory fitted inside the boiler casing - mounted on the outlet of the condensing heat exchanger - in an accessible position to allow for routine maintenance.

! NOTE !

If required, this condensate trap may be re-located outside the boiler casing. Refer to the procedure given in Section 6.9. This procedure must be carried out before the boiler is installed.

This trap incorporates a float (which will create a seal when the trap is empty) and an overflow warning outlet (fitted with a plastic sealing cap), see Figure 6-2.



Figure 6-2: Condensate trap

A 'push-fit' elbow connects the outlet of the condensing heat exchanger to the trap inlet. Ensure the elbow connector on the hose is fully pushed onto the 'top hat' inlet connector of the trap.

With the trap fitted inside the boiler casing, the sealing cap must be fitted. If the trap is re-located outside the boiler then the following applies:

- If connecting the condensate discharge - either internally or externally - into a waste system or soil stack - the sealing cap must be fitted in the trap outlet.
- On external discharge systems to a hopper, gully or soakaway, the sealing cap should be removed from the trap outlet.
- If there is any discharge of condensate from the overflow outlet, this could indicate a blockage (possibly due to freezing). Turn off the boiler and investigate the cause. If necessary contact your service engineer for assistance.

! WARNING !

Care should be taken when siting the trap such that the overflow outlet is readily visible and that any condensate overflowing from the outlet cannot cause either a hazard to persons or damage to surrounding property or equipment.

6.7 CONDENSATE DISPOSAL PIPEWORK

The condensate trap outlet is at an angle of 48° below the horizontal. This is to automatically give a 3° fall on any 'horizontal' runs of condensate disposal pipe. Refer to Figure 6-1 and see trap outlet/pipe.

The outlet of the trap will accept 21.5 mm to 23 mm OD Polypropylene overflow pipe for the condensate discharge pipe.

This discharge pipe can exit through the left side of the boiler through one of two pre-cut 'knock-outs' in the lower part of the left casing panel. Push out the 'knock-out' from the required hole taking care not to distort the side panel.

! NOTE !

When connecting plastic discharge pipe, ensure that the pipe is fully pushed into the outlet end on the flexible hose to prevent the possibility of leakage.

6.8 INSPECTION AND CLEANING OF TRAP

The trap **must** be checked at regular intervals (e.g. on every annual service) and cleaned as necessary to ensure that it is clear and able to operate.

The bottom bowl can be unscrewed from the trap body for inspection and cleaning.

To inspect and clean the trap:

1. Disconnect flexible condensate hose from inlet connector.
2. Unscrew the inlet connection nut.
3. Remove the inlet connector and nut from trap.
4. Disconnect the condensate disposal pipe from the trap outlet.
5. Remove trap from bracket.
6. Remove float from trap – clean if necessary.
7. Inspect inside of trap and clean as necessary.
8. Re-assemble trap, re-fit to boiler and re-connect flexible hose. Ensure that hose is fully pushed onto the trap inlet connector.

! CAUTION !

Failure to regularly check and clean the condensate trap may result in damage to the boiler and will not be covered by the product guarantee.

7 SEALED SYSTEMS

7.1 SEALED SYSTEM REQUIREMENTS

All Grant Vortex Eco Wall Hung models are suitable for use with sealed systems complying with the requirements of BS EN 12828, BS EN 12831 and BS EN 14336.

The system must be provided with the following items:

- Diaphragm expansion vessel complying with BS EN 13831
- Pressure gauge
- Pressure relief (safety) valve
- Approved method for filling the system

7.1.1 EXPANSION VESSEL

The expansion vessel should be fitted in the return pipework as shown in Figure 7-2. To reduce the operating temperature of the expansion vessel, position it below the pipe to which it is connected.

The expansion vessel may be positioned away from the system, providing the connecting pipe is not less than 13 mm diameter. If the expansion vessel is connected via a flexible hose, care must be taken to ensure that the hose is not twisted or kinked.

! NOTE !

Ensure that the expansion vessel used is of sufficient size for the system volume.

Refer to BS 7074-1 or The Domestic Heating Design Guide for sizing the required vessel.

7.1.2 PRESSURE GAUGE

The pressure gauge must have an operating range of 0 to 4 bar. It must be located in an accessible place next to the filling loop for the system.

7.1.3 SAFETY VALVE

The safety valve should be fitted in the flow pipework near to the boiler.

The pipework between the safety valve and boiler must be unrestricted, i.e. no valves. The safety valve should be connected to a discharge pipe which will allow the discharge to be seen, but cannot cause injury to persons or damage to property.

7.1.4 FILLING LOOP

Provision should be made to replace water lost from the

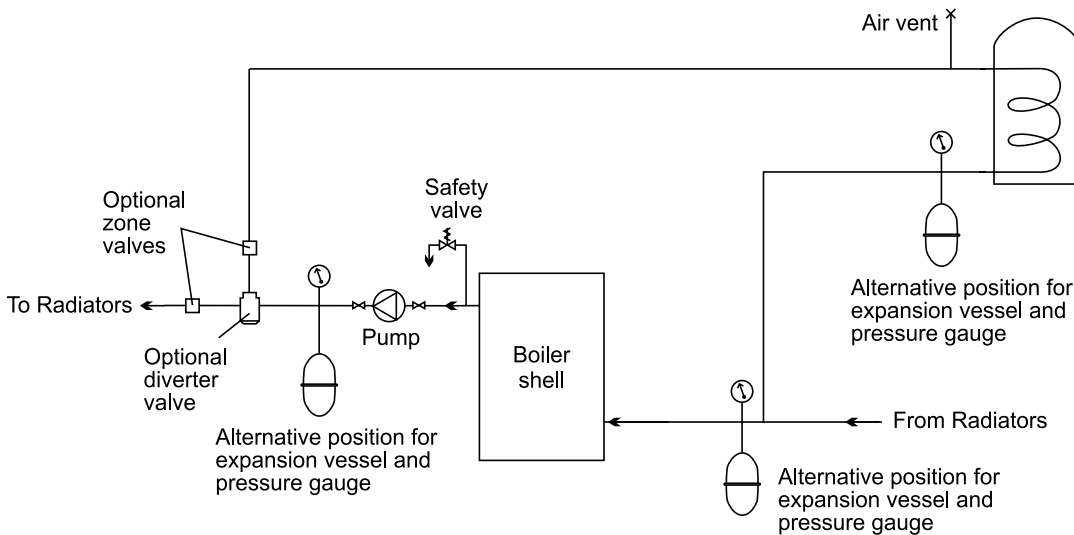

Figure 7-1: Sealed system

If thermostatic radiator valves are fitted, the system **must** incorporate an adequate by-pass.

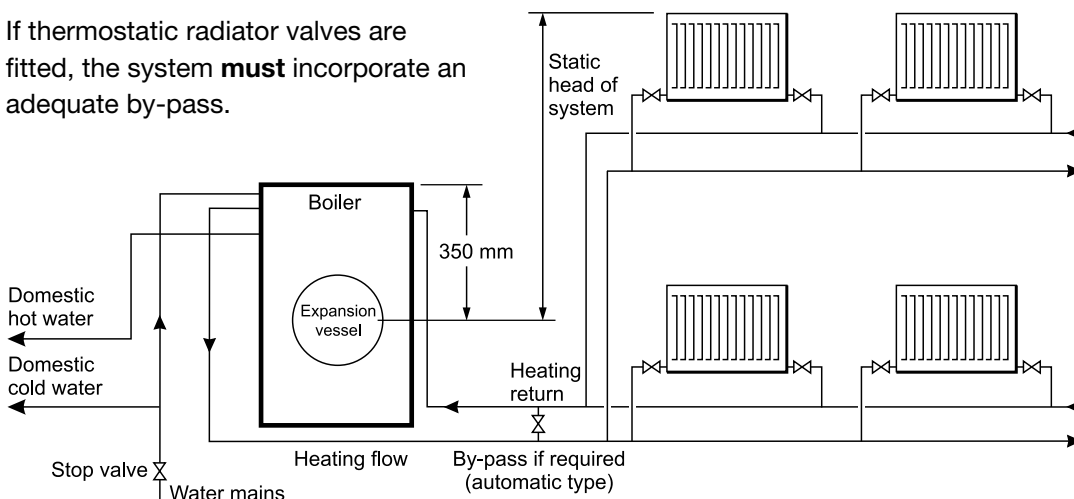

Figure 7-2: Sealed system boilers

system. This can be done manually (where allowed by the local water undertaking) using an approved filling loop arrangement incorporating a double check valve assembly.

The filling loop must be isolated and disconnected after filling the system.

7.1.5 HEATING SYSTEM

The maximum 'setpoint' temperature for the central heating water is 75°C. Refer to Section 1.1.

An automatic air vent should be fitted in the flow and return pipes of the highest point of the system.

If thermostatic radiator valves are fitted to all radiators, a system by-pass must be fitted. The by-pass must be an automatic type.

All fittings used in the system must be able to withstand pressures up to 3 bar. Radiator valves must comply with the requirements of BS 2767.

One or more drain taps (to BS 2879) must be used to allow the system to be completely drained.

7.2 FILLING THE SEALED SYSTEM

Filling of the system must be carried out in a manner approved by the local Water Undertaking.

! WARNING !

Only ever fill or add water to the system when it is cold and the boiler is off. Do not overfill.

The procedure for filling the sealed system is as follows:

1. Check the air charge pressure in the expansion vessel BEFORE filling the system.
The expansion vessel charge pressure should always be slightly greater than the maximum static head of the system, in bar, at the level of the vessel (1 bar = 10.2 metres of water). Refer to Figure 7-2.
The charge pressure must not be less than the actual static head at the point of connection.

! NOTE !

The air charge pressure may be checked using a tyre pressure gauge on the expansion vessel Schraeder valve. The vessel may be re-pressurised, when necessary, using a suitable pump. When checking the air pressure, the water in the heating system must be cold and the system pressure reduced to zero.

1. Check that the small cap (or screw) on all automatic air vents is open at least one turn. The cap (or screw) remains in this position from now on.
2. Ensure that the flexible filling loop is connected and that the double check shut off valve connecting it to the water supply is closed. A valve is open when the operating lever is in line with the valve, and closed when it is at right angles to it.
3. Open the fill point valve.
4. Gradually open the double check valve from the water supply until water is heard to flow.
5. When the needle of the pressure gauge is between 0.5 and 1.0 bar, close the valve.
6. Vent each radiator in turn, starting with the lowest one in the system, to remove air.
7. Continue to fill the system until the pressure gauge indicates between 0.5 and 1.0 bar. Close the fill point valve. The system fill pressure (cold) should be 0.2 - 0.3 bar greater than the vessel charge pressure – giving typical system fill pressures of approx 0.5 bar for a bungalow and 1.0 bar for a two storey house.
Refer to the Domestic Heating Design Guide for further information if required.
8. Repeat steps 4 and 5 as required until system is full of water at the correct pressure and vented.
9. Water may be released from the system by manually

operating the safety valve until the system design pressure is obtained.

10. Close the fill point and double check valves either side of the filling loop and disconnect the loop.
11. Check the system for water soundness, rectifying where necessary.

7.3 VENTING THE PUMP

For those heating circulating pumps fitted with a vent plug, it is important that the pump is properly vented to avoid an air lock and also prevent it running dry and damaging the bearings.

Unscrew and remove the plug from the centre of the pump motor. Using a suitable screwdriver, rotate the pump spindle about one turn. Replace the plug in the motor. Do not over tighten.

! NOTE !

Some heating circulating pumps are not fitted with a vent plug so it is not possible to vent these pumps in the manner described above. Refer to pump manufacturers own instructions for further details.

7.4 PRESSURE RELIEF (SAFETY) VALVE OPERATION

Check the operation of the pressure relief (safety) valve as follows:

1. Turning the head of the valve anticlockwise until it clicks. The click is the safety valve head lifting off its seat allowing water to escape from the system.
2. Check that the water is escaping from the system.
3. Top-up the system pressure, as necessary.

8 ELECTRICAL

8.1 GENERAL

Grant Vortex Eco models requires a ~230V 1ph 50Hz supply. It must be protected by a 5 Amp fuse.

Refer to Figures 8-1 to 8-4 for typical control system wiring diagrams for all models.

Refer to Figures 8-5 and 8-6 for wiring diagrams for all models.

! WARNING !

The Vortex boiler contains electrical switching equipment and must be earthed.

The supply must be fused at 5 Amp and there must only be one common isolator for the boiler and control system, providing complete electrical isolation.

A fused double pole switch or a fused three pin plug and shuttered outlet socket should be used for the connection.

The power supply cable should be at least 0.75 mm² PVC as specified in BS 6500, Table 16.

All the wiring and supplementary earth bonding external to the boiler must be in accordance with the current IET Wiring Regulations.

Any room thermostat or frost thermostat used must be suitable for use on mains voltage.

In the event of an electrical fault after installation of the boiler, the following electrical system checks must be carried out:

- Short circuit
- Polarity
- Earth continuity
- Resistance to earth

8.2 CONNECTING THE POWER SUPPLY

It is recommend that the boiler should be connected to a switched mains power supply from a programmer or control system.

A three core cable is required to connect the boiler terminal block to the live supply. Refer to Figures 8-1 to 8-4 for typical control system wiring diagrams.

! NOTE !

Ensure that the route and length of the supply cable is such that the boiler control panel can be hooked to the top panel of the casing during the service operation.

The procedure is:

1. Remove the lower and upper front panels, if they have not already been removed.
2. Remove the top of the control panel or the wiring cover (on Kitchen models) and open the cable clamp.
3. Route the supply cable through the hole in the rear panel (using the grommet supplied) up to the control panel, pass it through the cable clamp and connect to the boiler terminal block as follows:
 - Brown to live (terminal 1)
 - Blue to mains neutral (terminal 2)
 - Green/Yellow to mains earth (terminal 3)

8.3 FROST PROTECTION

For additional protection of either the entire heating system, or the boiler and localised pipework, it is recommended that a frost thermostat be installed.

Refer to Figures 8-1 to 8-4 (as appropriate) for connection details.

To protect the heating system, the frost thermostat should be sited within the house in such a place that it can detect any rise and fall in the ambient air temperature, i.e. in a room with a radiator.

Where the frost thermostat is installed outside the house (to protect a boiler installed in an external boiler room or garage) or in an attic, it is recommended that it be used in conjunction with a pipe thermostat to avoid unnecessary and wasteful overheating of the property.

The pipe thermostat should be located on the boiler return pipe, and set to operate at 25 C.

Refer to Figures 8-1 to 8-4 (as appropriate) for connection details.

8.4 CONTROL SYSTEM WIRING DIAGRAMS

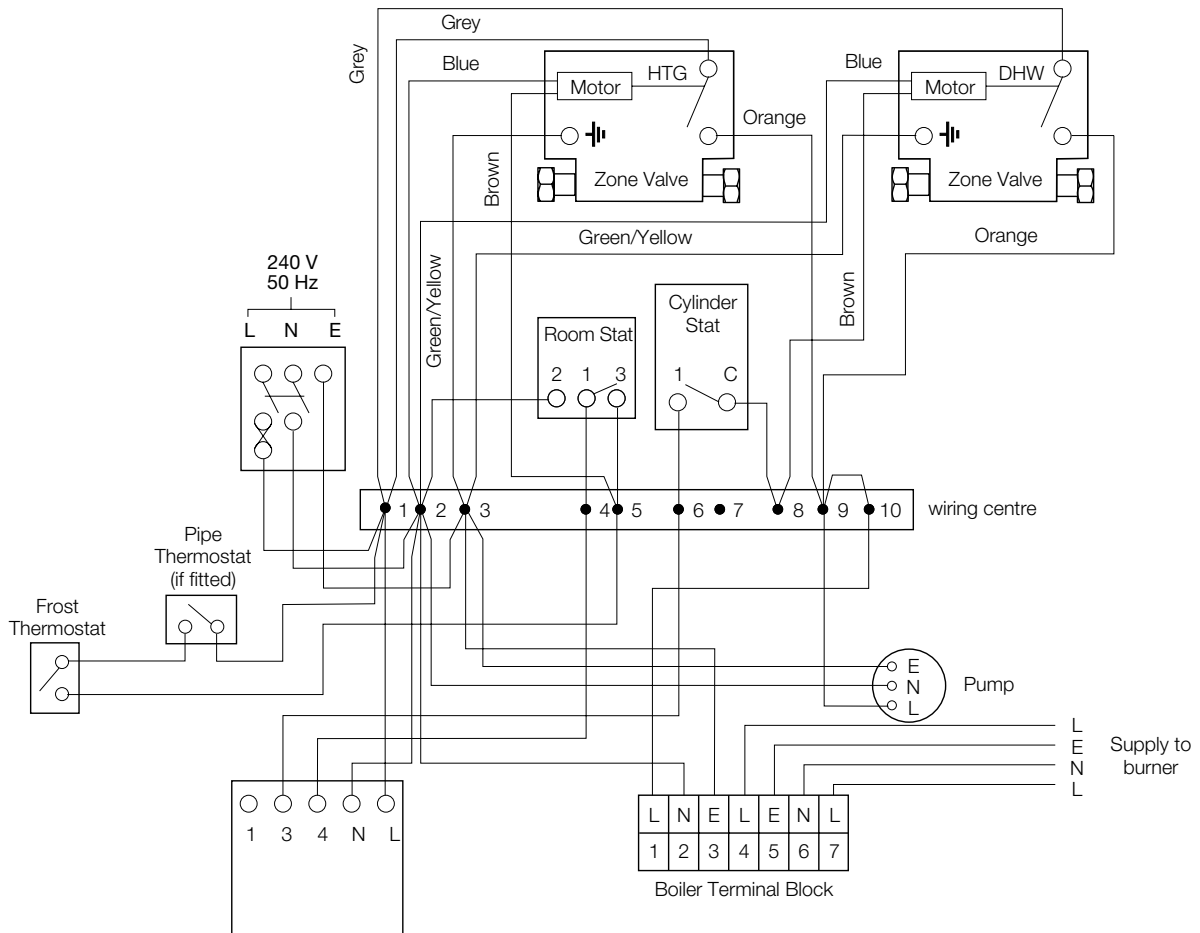

Figure 8-1: Internal wall hung - 2 X 2-port valve control system

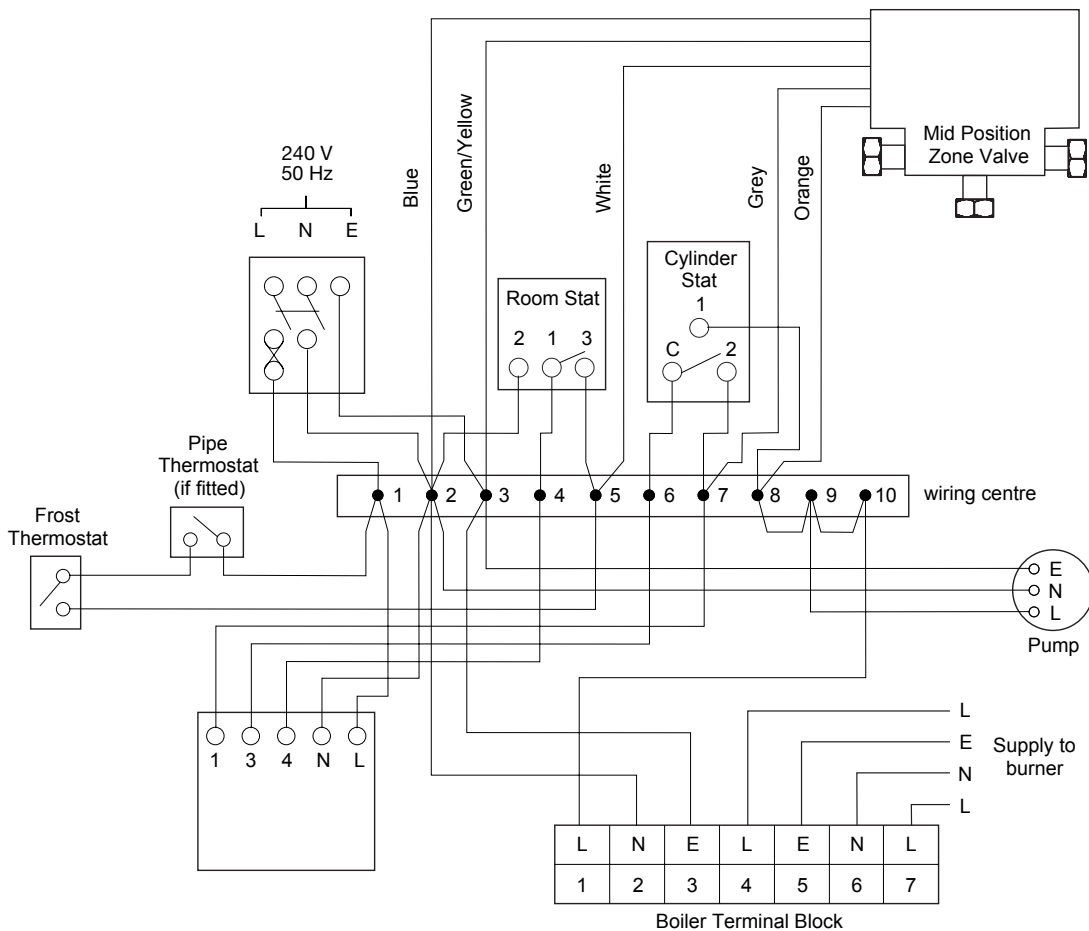

Figure 8-2: Internal wall hung - 3-port valve control system

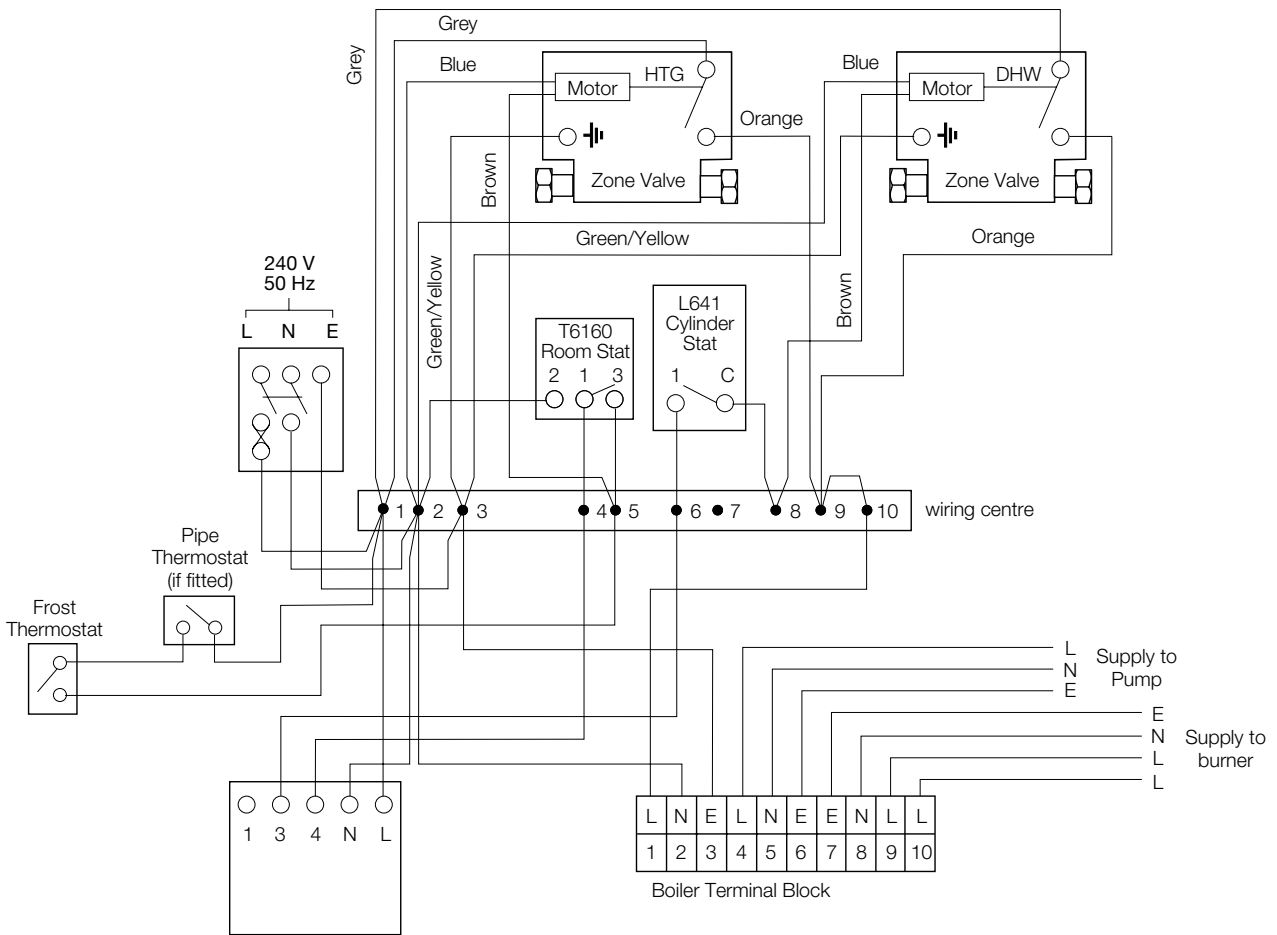

Figure 8-3: Internal system wall hung - 2 X 2-port valve control system

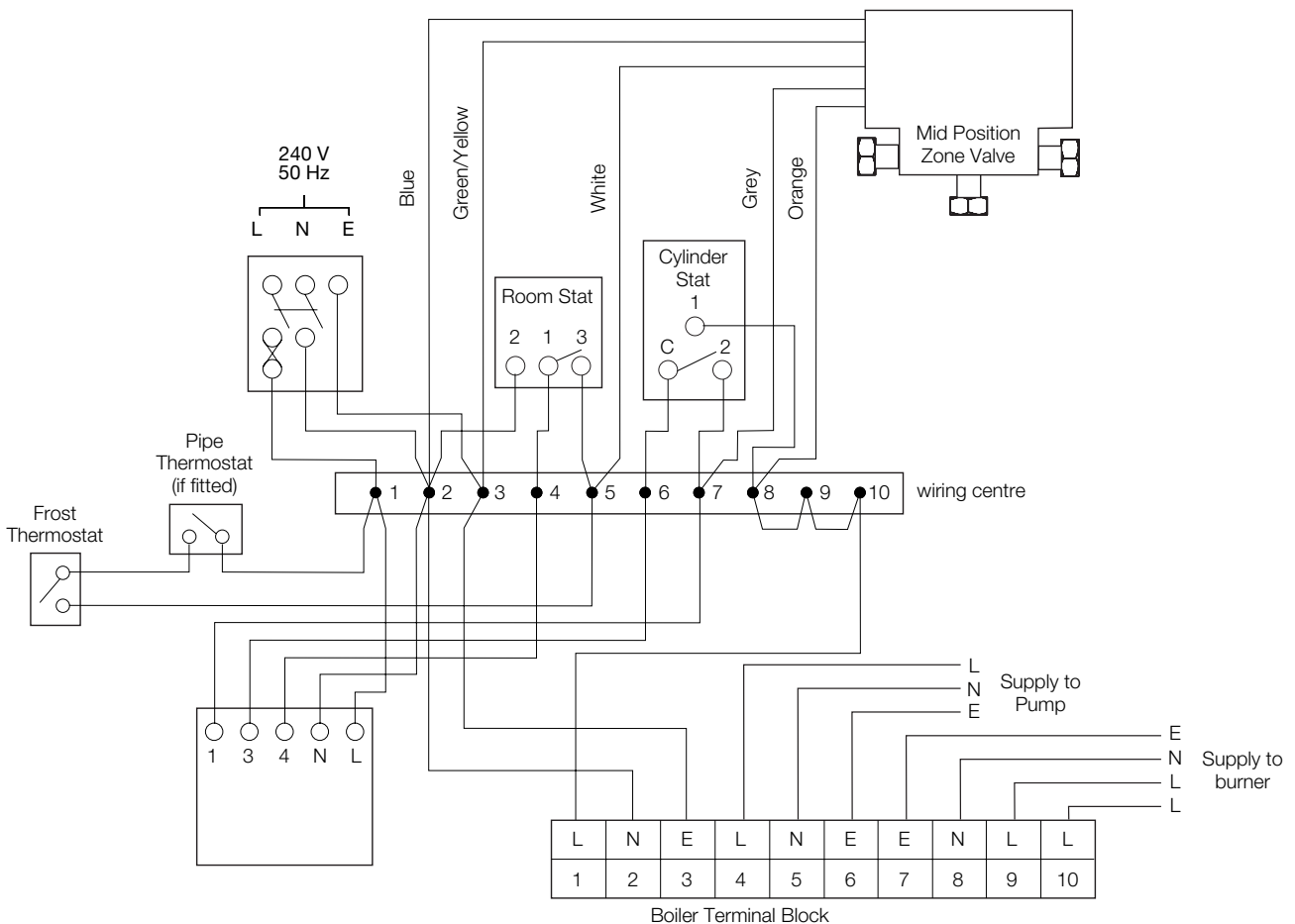

Figure 8-4: Internal system wall hung - 3-port valve control system

8.5 BOILER CONTROL PANEL WIRING DIAGRAMS

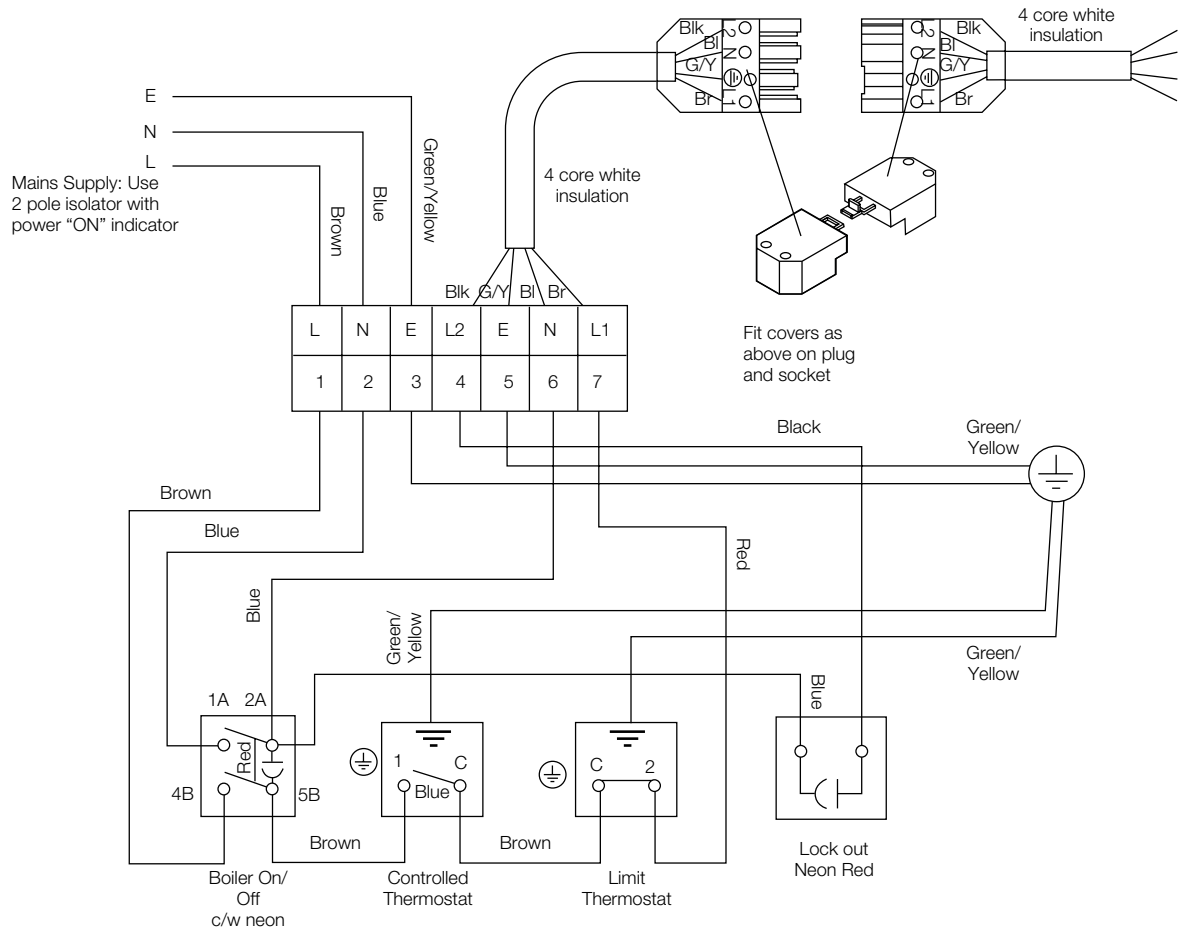

Figure 8-5: Internal wall hung - wiring diagram

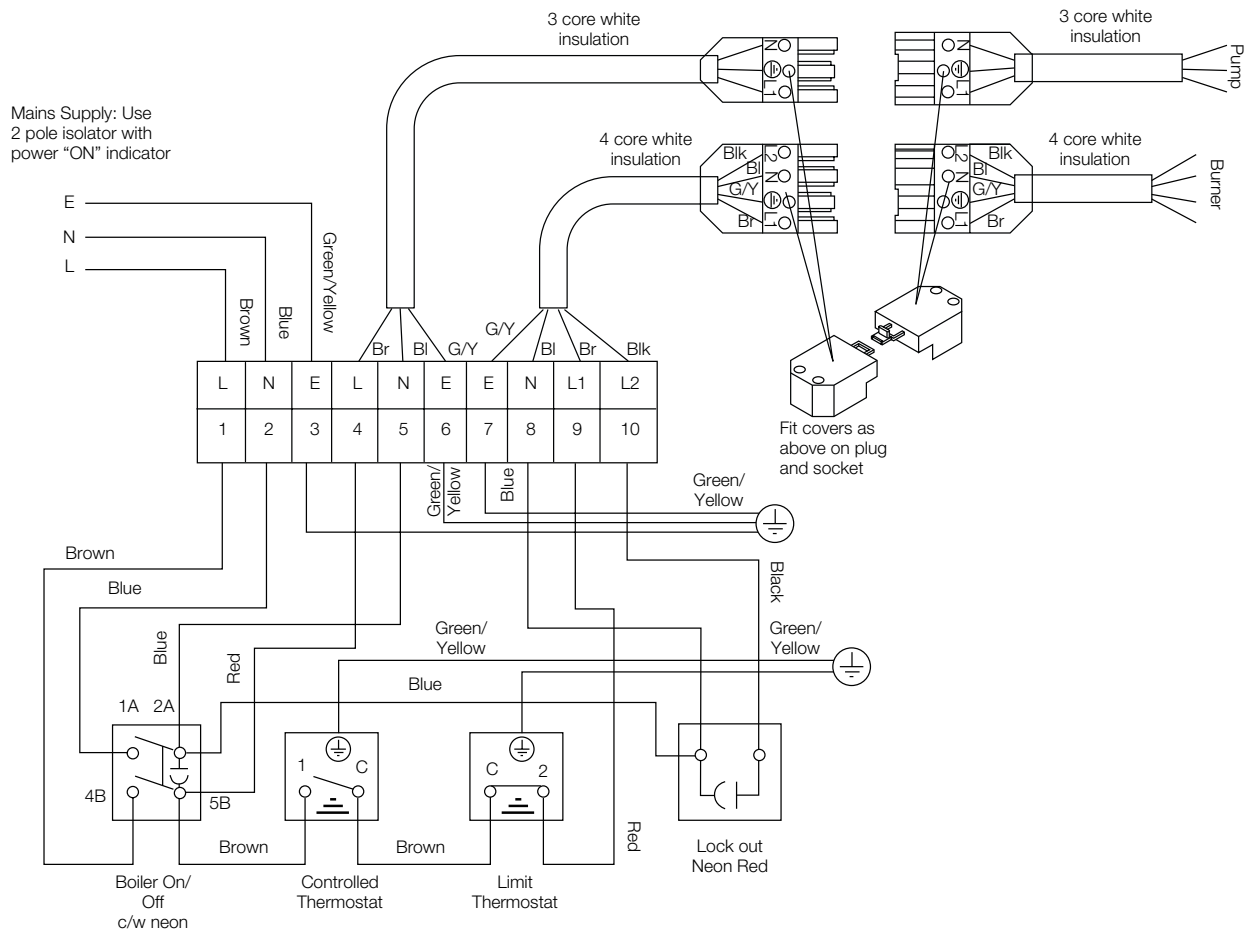

Figure 8-6: Internal system wall hung - wiring diagram

9 FLUE SYSTEM AND AIR SUPPLY

9.1 AIR SUPPLY

A sufficient permanent air supply to the boiler should be provided for the following reasons:

- For proper combustion of fuel and effective discharge of combustion products to the open air.
- For the ventilation of any confined space in which the boiler is installed to prevent overheating of the boiler and any equipment in and near the boiler.

It should be both the designer's and installer's concern that the air required for these functions be introduced so as to cause as little discomfort as possible to the building occupants and thus to offer them the least temptation to obstruct the ventilators.

Further details may be obtained from BS 5410-1.

! NOTE !

For a boiler fitted in a compartment, which is ventilated as shown, no additional allowance is necessary.

Open flue - Extract fans, where needed, should be in accordance with Section 5.4.7 in BS 5410-1.

All ventilation areas given are for domestic applications and relate to the full output rating of the boiler.

For installations in older dwellings (constructed prior to the introduction of Approved Document L1A 2006) the first 5 kW of output can be ignored. For all other cases refer to BS 5410-2.

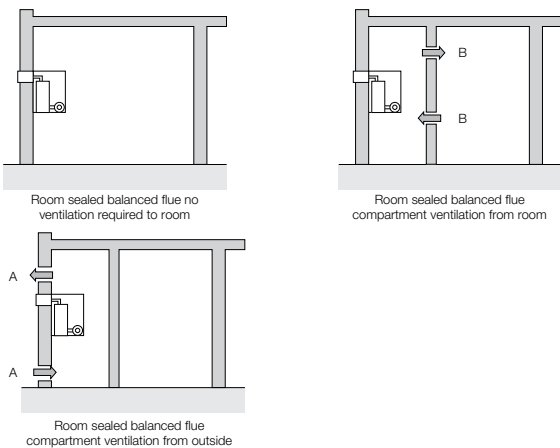

Figure 9-1: Air supply for room sealed balanced flue boilers

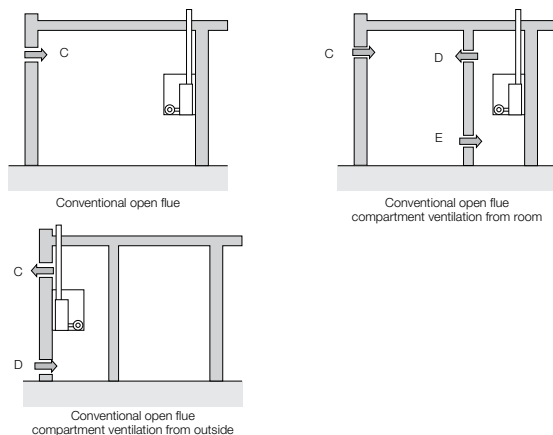

Figure 9-2: Air supply for conventional flue boilers

Table 9-3: Ventilation areas

Output	12/16		16/21	
	Area	cm ²	in ²	cm ²
Vent A	83	13	116	18
Vent B	165	26	231	36
Vent C	83	13	116	18
Vent D	165	26	231	36
Vent E	248	38	347	54

9.2 CONVENTIONAL FLUE SYSTEMS

! NOTE !

Under no circumstances can Grant Vortex boilers be installed with existing flue systems. Only flue systems and components suitable for wet flues should be used.

Failure to install the correct type of flue system will invalidate the guarantee.

Grant condensing boilers have high operating efficiencies and low flue gas temperatures. Care must be taken to ensure the flue system is suitable for the very low flue gas temperatures and condensate in the flue gases.

Suitable conventional flue systems are available from Grant UK.

The flue must terminate in a down draught free area, i.e. at least 600 mm above the point of exit through the roof or preferably above the ridge level.

The condensate may be allowed to run back into the boiler. A condensate drain at the base of the flue system is not required.

The high level flue terminal must be at least 600 mm from any opening into the building, and 600 mm above any vertical structure or wall less than a horizontal distance of 750 mm from the terminal.

If an existing chimney is to be used, it must be lined with a smooth bore stainless steel liner suitable for use with oil fired condensing boilers. The top and bottom of the annular space must be sealed.

Grant recommends the use of the Grant 'Orange' flue system, specifically designed for the Vortex range of condensing boilers.

The internal flue and liner diameter for all models up to 46 kW output must be 100 mm (4 in) and for the 46/58 and 58/70 models 125 mm (5 in).

The maximum vertical height (from the top of the boiler to the terminal) for the 'Orange' system is 19 metres.

! NOTE !

The Grant Orange system flexible stainless steel liner is directional. The arrows marked on the liner MUST be pointing vertically upwards, following the direction of the flue gases. Failure to comply with this instruction could lead to a leakage of condensate from the flue liner.

If a rigid flue is used externally, it must be of the twin-wall type incorporating seals at all joints, constructed with a stainless steel inner skin and be suitably insulated and weatherproofed. The internal flue diameter for a rigid flue for all models - up to and including the 58/70 - is 100 mm (4 in). Use the larger '200' size of 'Green' system components as listed in Figure 9-14.

Grant recommends the use of the Grant 'Green' and 'Orange' flue system components for this application. Refer to Section 1.3 for details.

! NOTE !

As no flue adaptor is supplied with the boiler, in order to correctly connect the hybrid system, it will be necessary to purchase the Grant CF adaptor kit (product code: CFA15/70).

If required, it is possible to use the white painted single-wall straight flue extensions, adjustable extensions and elbows from the Grant 'Orange' system for the internal section of the flue system, see Figure 9-6. These components can be fitted between the boiler connector and flue adaptor. The flue adaptor, to which the external twin-wall 'Green' flue components are connected, can therefore be situated just before the flue system passes through the wall.

! NOTE !

Grant 'Orange' system single-wall flue components must not be used externally.

The maximum vertical height (from the top of the boiler to the terminal) for the 100 mm diameter hybrid 'Green/Yellow' system is 8 metres.

Grant 'Green' twin-wall flue is recommended for externally run flues to reduce the possibility of the condensate freezing in the flue.

No part of any flue system should be made of an asbestos material; aluminium must not be used in any part of the flue.

Only stainless steel flue components should be used.

If the draught conditions are satisfactory, the flue should terminate with a standard cowl.

Refer to the locally applicable Building Regulations, BS 5410:1 and OFTEC Installation Requirements (OFTEC Technical Books 2 and 4) for further guidance on conventional flue systems.

! CAUTION !

Caution concerning likely damage to equipment or tools as a consequence of not following the instructions in the caution.

Only use flue systems suitable for oil fired condensing boilers.

Do not use fire cement. The use of high temperature silicone sealants is recommended.

! NOTE !

To comply with the requirements of the Building Regulations Approved Document J - conventional flue systems must have a flue data plate. A suitable data plate is supplied with the Grant Orange flue system and should be displayed next to the boiler or flue.

FLUE LINING KITS

Grant EZ-Fit Flexi Pack conventional flue system (Orange System)

A range of Flexi pack conventional flue lining kits are available from Grant UK. The packs have been specifically produced for Grant Vortex oil fired condensing boilers.

The pack includes a terminal/top plate/flexi flue adaptor, stainless steel smooth bore flexible flue liner, a rigid to flexi adaptor and a boiler flue connector.

Two diameters are available, a 100 mm for models up to 46 kW and 125 mm for models above 46 kW.

Table 9-4: Conventional flue kits

Product code	Flexi pack (Orange system)
GFKIT 6/100	100 mm diameter x 6 metre
GFKIT 6/125	125 mm diameter x 6 metre
GFKIT 8/100	100mm diameter x 8 metre
GFKIT 8/125	125mm diameter x 8 metre
GFKIT 10/100	100mm diameter x 10 metre
GFKIT 10/125	125mm diameter x 10 metre
GFKIT 11/100	100mm diameter x 11 metre
GFKIT 11/125	125mm diameter x 11 metre
GFKIT 12/100	100mm diameter x 12 metre
GFKIT 12/125	125mm diameter x 12 metre
GFKIT 14/100	100mm diameter x 14 metre
GFKIT 14/125	125mm diameter x 14 metre
GFKIT 16/100	100mm diameter x 16 metre
GFKIT 16/125	125mm diameter x 16 metre

Extensions

A range of white powder coated single wall extensions are available to connect the boiler to the flexible liner.

The nominal diameter of the extensions is 100 mm or 125 mm.

Extensions are supplied with locking bands.

Table 9-5: Extensions

Product code	Extensions (Orange system)
WX 150/100	100 mm diameter x 150 mm
WX 150/125	125 mm diameter x 150 mm
WX 250/100	100 mm diameter x 250 mm
WX 250/125	125 mm diameter x 250 mm
WX 450/100	100 mm diameter x 450 mm
WX 450/125	125 mm diameter x 450 mm
WX 950/100	100 mm diameter x 950 mm
WX 950/125	125 mm diameter x 950 mm

Flue extensions cannot be cut.

Also available are:

- An adjustable extension (235 to 300 mm)
- 45° elbow

! NOTE !

The rigid flue between the boiler and flexible flue liner should incorporate an adjustable section to allow inspection and cleaning of the flue system.

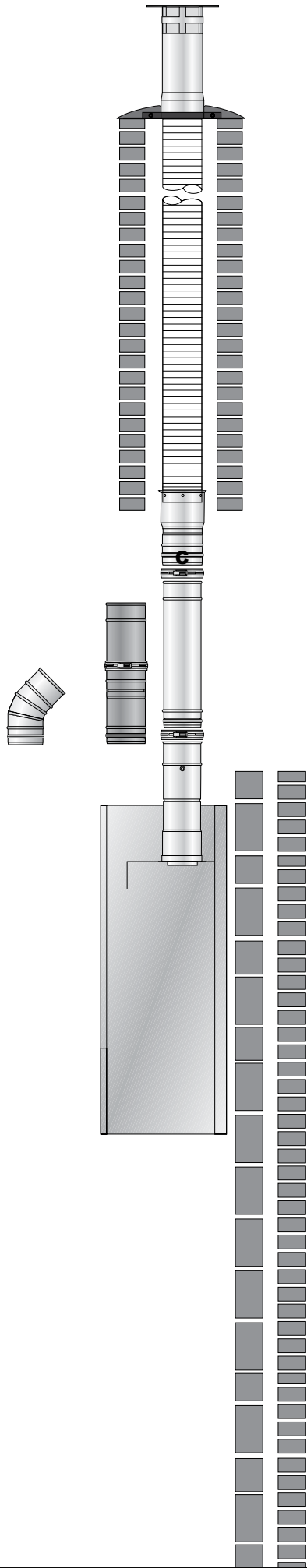

Figure 9-6: Grant Orange flue system in a typical brick chimney

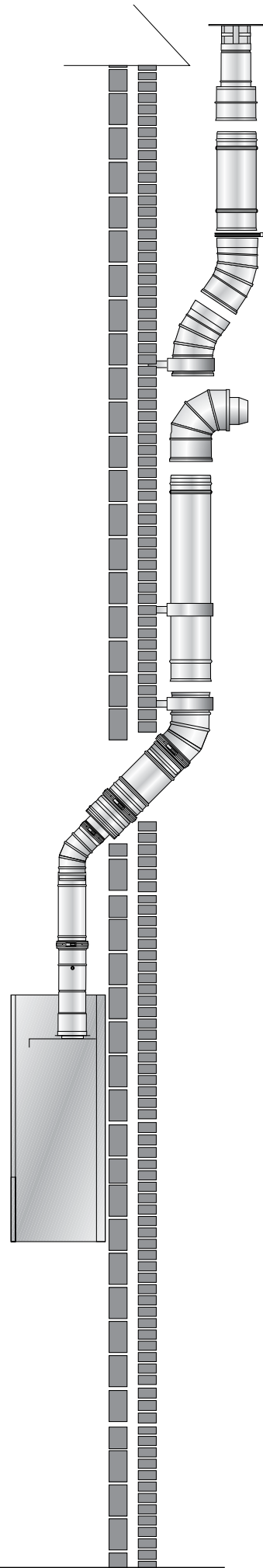

Figure 9-7: Hybrid flue system using Grant Orange and Green systems components

9.3 CONNECTING A CONVENTIONAL FLUE

If the Grant 'Orange' flue system is being used – follow the instructions supplied with the flue kit.

If the Grant 'Green' system (100 mm rigid twin-wall flue) is to be fitted to the boiler then the Grant CF adaptor kit (product code: CFA15/70) must be used – refer to Section 1.3.

To fit the adaptor kit, proceed as follows:

1. Fully screw the length of threaded studding (provided in the kit) into the nut located in the centre of the boiler flue outlet.
2. Fit the boiler connector (from the CF adaptor kit) over the threaded studding.
3. Position flange on to the neoprene gasket around the boiler flue outlet, ensuring that small spigot on the base of the connector is located in the hole in the centre of the neoprene gasket and that end of studding passes through the hole in the of the spacer bracket.
4. Fit washer and wing nut provided onto the end of threaded studding and secure connector in position by tightening down on wing nut – as shown in Figure 9-8.
5. Fit the flue adaptor (from the adaptor kit) into the boiler connector.

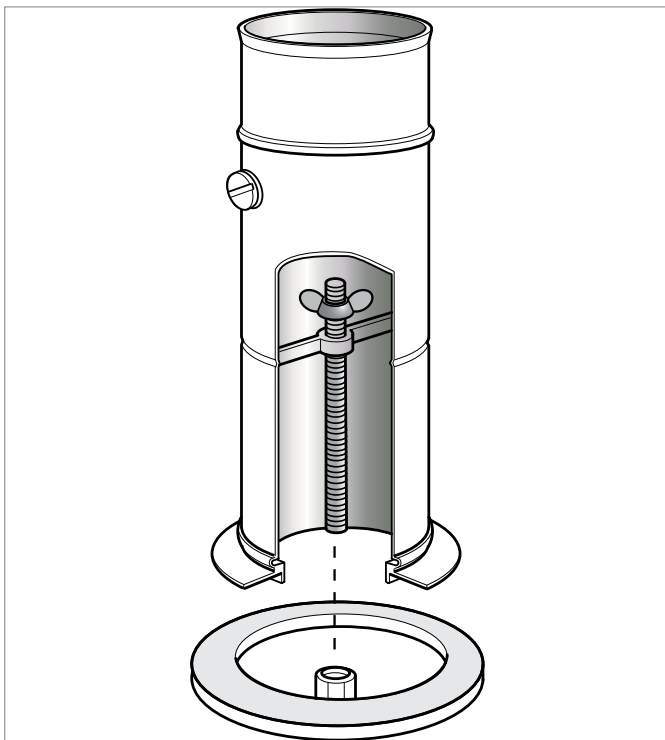

Figure 9-8: Boiler flue connector

! NOTE !

Lubricate the seal on the adaptor using the lubricant provided before attempting to fit the flue adaptor.

6. Fit the first section of flue into the flue adaptor and secure using the clamp band provided.
7. Assemble the remainder of the flue system as required, lubricating the seal on each component before fitting.

9.4 BALANCED FLUE SYSTEMS

Apart from a conventional flue, several balanced flue options are available for use with the Grant Vortex boilers.

All are suitable for use with Class C2 Kerosene.

! NOTE !

None of the flue sections in the following system can be cut.

LOW LEVEL HORIZONTAL BALANCED FLUE (YELLOW SYSTEM)

Available in Short (for single thickness brick walls) and Standard kits.

Extensions are available which extend the flue by 225 mm, 450 mm or 675 mm.

90° and 45° elbows are also available.

The maximum flue length - from the centre of the boiler flue outlet to the outer face of the wall - is 4 metres (with or without elbows included).

No more than 2 x 45° or 1 x 90° elbow should be fitted per system.

The low level balanced flue (Yellow system) is supplied with a stainless steel guard. This must be fitted in all circumstances to prevent objects from entering the flue outlet.

The guard must be fitted centrally over the flue terminal and securely fixed to the wall.

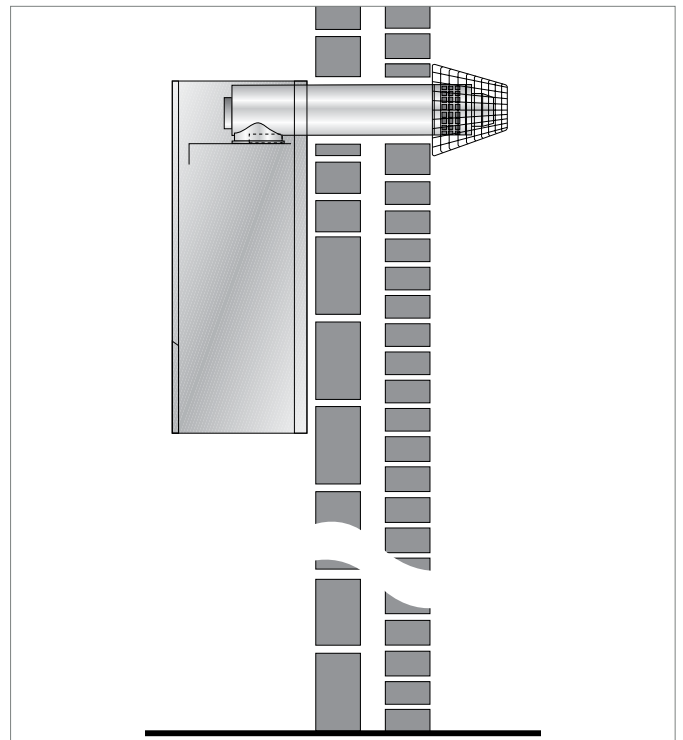

Figure 9-9: Low level balanced flue

HIGH LEVEL (HORIZONTAL) BALANCED FLUE (WHITE SYSTEM)

The High Level (horizontal) balanced flue (White system) allows the flue to rise vertically within the building before exiting through the wall horizontally.

The maximum flue length - from the top of the boiler flue outlet to the outer face of the wall - is 10 metres for all Grant Vortex boilers.

The following items are additionally available:

- Extensions to extend the flue by 225 mm, 450 mm or 950 mm.
- An adjustable extension of 275 to 450 mm.
- A 45° elbow - No more than 6 x 45° elbows should be fitted per system. Each elbow reduces the overall maximum length of the system by 1 metre.

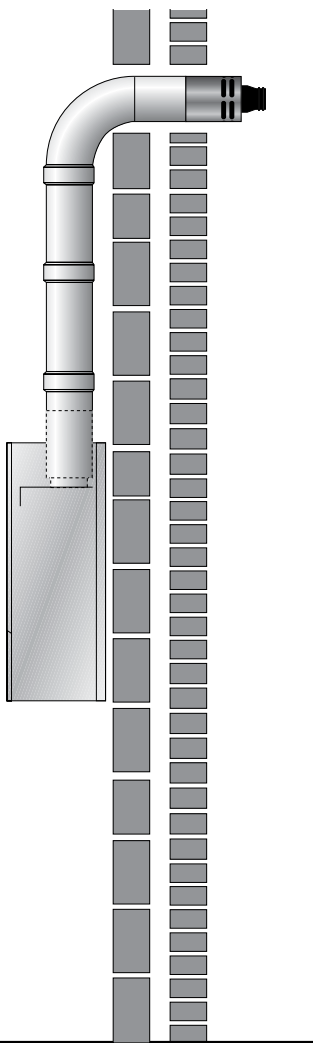

Figure 9-10: High level balanced flue

VERTICAL BALANCED FLUE (WHITE SYSTEM)

Allows the flue to rise vertically from the boiler to exit through the roof.

The maximum flue length - from the top of the boiler flue outlet to the terminal - is 12 metres for all Vortex boilers.

The following items are additionally available:

- Extensions to extend the flue by 225 mm, 450 mm or 950 mm.
- An adjustable extension of 275 to 450 mm.
- A 45° elbow - No more than 6 x 45° elbows should be fitted per system. Each elbow reduces the overall maximum length of the system by 1 metre.

Table 9-11: White system components - product codes

Item	12/16 and 16/21 models
1.2 metre high level adjustable flue kit c/w 90° elbow and terminal	HLK015090
Adjustable vertical 3 metre flue kit c/w terminal and storm collar	VTK055090
225 mm extension	EXTK31225/90
450 mm extension	EXTK09450/90
950 mm extension	EXTK11950/90
275 to 450 mm adjustable extension	EXTK13ADJ/90
45° elbow	ELBK2145/90
Pitched roof flashing - aluminium (VTK055090 and VTK0690200)	VTMF200
Pitched roof flashing - lead	VTK25P90 (includes collar)
Flat roof flashing - aluminium	VTK27F90
Wall bracket	BRK2990

FLEXIBLE VERTICAL BALANCED FLUE (RED SYSTEM)

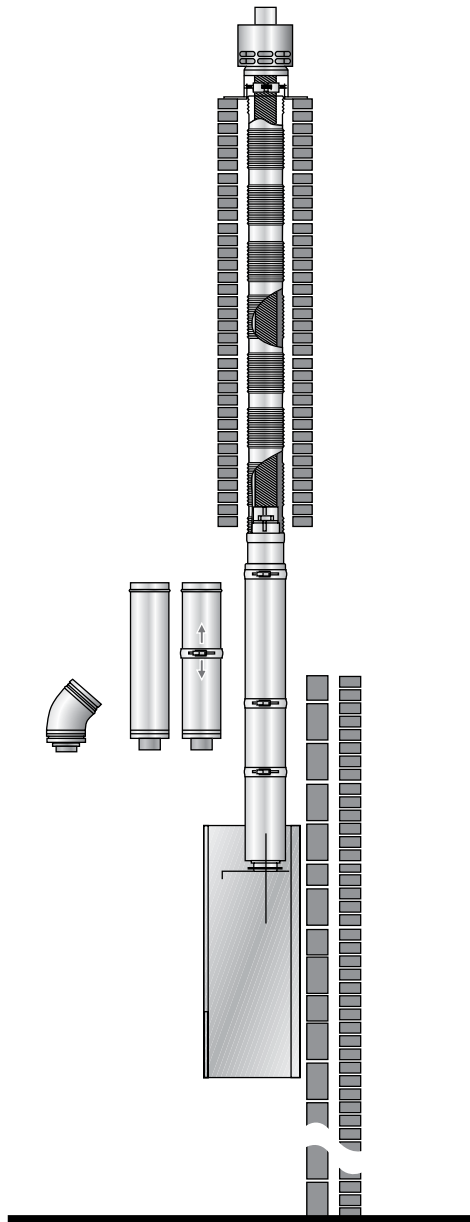

Figure 9-12: Red system balanced flue

This is a flexible vertical balanced flue system (for the 15/21 and 15/26 models only) designed to be fitted inside an existing masonry chimney. See Figure 9-12.

It basically consists of three sections:

- Concentric white painted flue pipe connected to the boiler.
- Vertical concentric flexible flue (flexible stainless steel flue liner inside a flexible plastic air inlet liner).
- Terminal assembly for chimney top mounting.

The flue pipe seals are factory fitted and must be lubricated with the lubricant supplied before assembly.

The Red system is supplied as a separate kit. Flue extensions and 45° elbows from the White system may be used to extend the flue between the boiler and the flexible section of the system.

The maximum vertical straight length of flue, from the top of the boiler to the top of the terminal, is 20 metres – using no more than four 45° elbows. Deduct 1 metre of straight flue length for every elbow used.

! NOTE !

One metre of straight flue length should be deducted for every elbow used. If the flexible liner has to pass around an offset in the chimney, two metres of straight flue length should be deducted to compensate for this, i.e. equivalent to two 45° elbows.

The Grant Red system flexible stainless steel liner is directional. The arrows marked on the liner **MUST** be pointing vertically upwards, following the direction of the flue gases. Failure to comply with this instruction could lead to a leakage of condensate from the flue liner.

Flue extensions cannot be cut, use adjustable extensions where required.

Three types of locking band are supplied with the kit.

The first type is for connecting flue sections that butt together (2 of this type of locking band are supplied).

The second type is to cover the joint on the adjustable (telescopic) section.

! NOTE !

The locking band for the adjustable section is labelled for easy identification.

The third locking band is plastic and supplied in two halves. This is to secure the plastic flexible liner to the adapter.

The flue kit includes a Black coated terminal with upstand and is designed to be fixed (using the screws provided) to the top of a masonry chimney.

The flue system may be offset using 45° elbows (product code: ELBK2145/90 models up to 26 kW output or ELBK22145/200 for models 26 to 70 kW output).

No more than a maximum of four elbows should be used per system.

EXTERNAL BALANCED FLUE (GREEN SYSTEM)

Where it is not practical to use a low level (Yellow system) or internal high level/vertical (White system) balanced flue, the boiler can be fitted with an external vertical/high level flue (Green system).

See Figure 9-13.

The Starter kit fits to the boiler in the same way as a low level balanced flue (Yellow system) and the external Tee allows the connection of a twin wall insulated flue pipe and a combustion air inlet - providing a room sealed flue system.

The external system can terminate at either high level or vertically (above roof level) as required.

See Figure 9-13.

The minimum dimensions for locating the terminal from building features (windows, doors, etc.) are shown in Figure 9-15.

The terminal must be positioned so as to avoid products of combustion accumulating in stagnant pockets around the buildings or entering into buildings. Care should be taken that the plume from condensed flue gases does not cause a nuisance.

The components listed on the following page for the external flue (Green system) components are available from Grant UK.

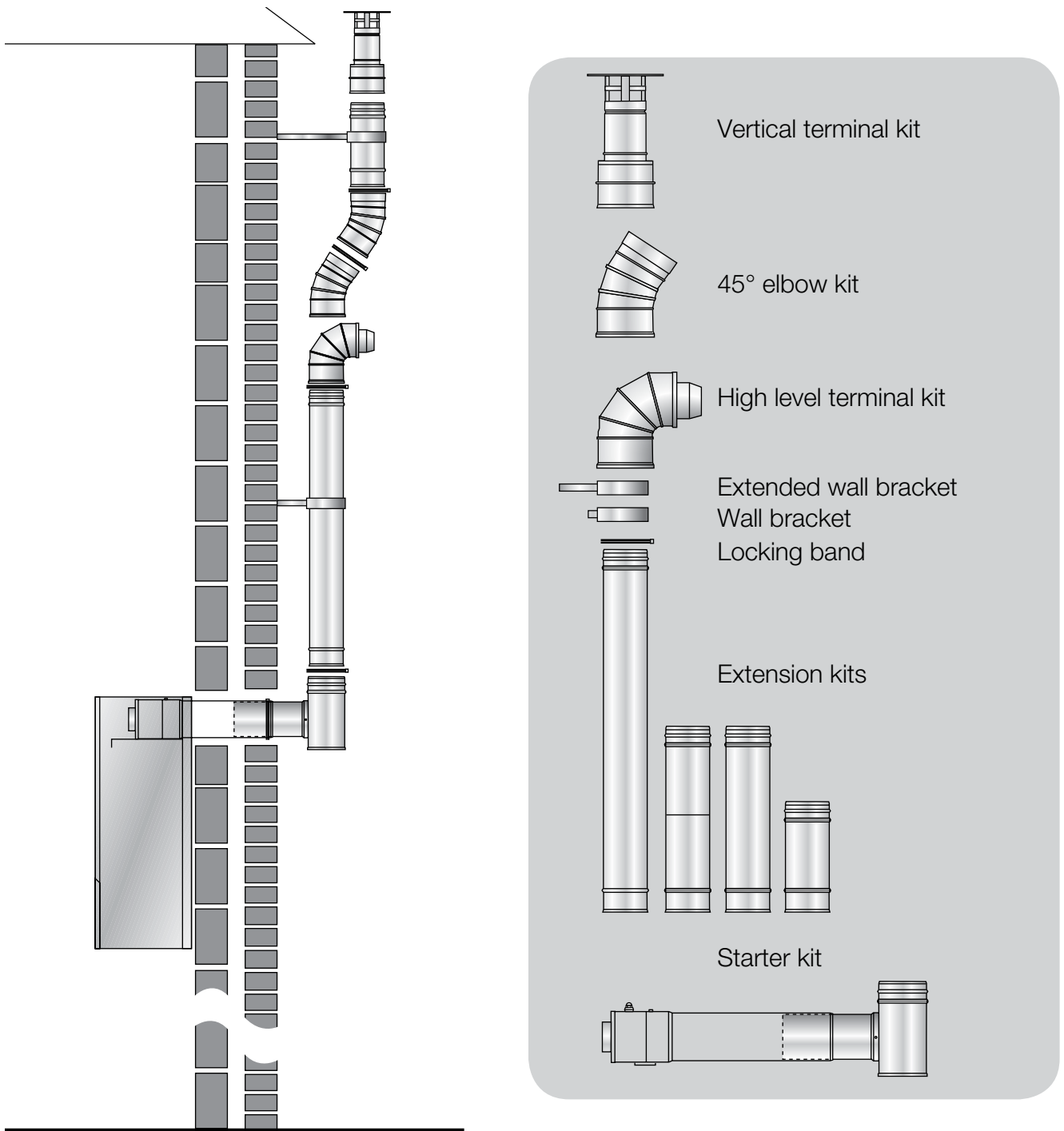

Figure 9-13: External balanced flue (green system)

Table 9-14: Green system components - product codes

Item	12/16 and 16/21 models
Standard starter kit (stainless steel)	GK90B
Short starter kit (stainless steel)	GK90SB
150 mm extension	GX150/90B
250 mm extension	GX250/90B
450 mm extension	GX450/90B
950 mm extension	GX950/90B
195 - 270 mm adjustable extension	GXA250/90B
45° elbow	GE45/90B
Straight terminal	GTL90B
High level 90° terminal	GTH90B
Vertical terminal	GTV90B
Wall bracket - standard	GWB90B
Wall bracket - extended	GEB90B

9.5 PREPARE THE WALL

9.5.1 LOW LEVEL BALANCED FLUE

If the boiler is to be used with a low level balanced flue (Yellow system) make the hole in the wall for the flue as shown in Figure 9-15.

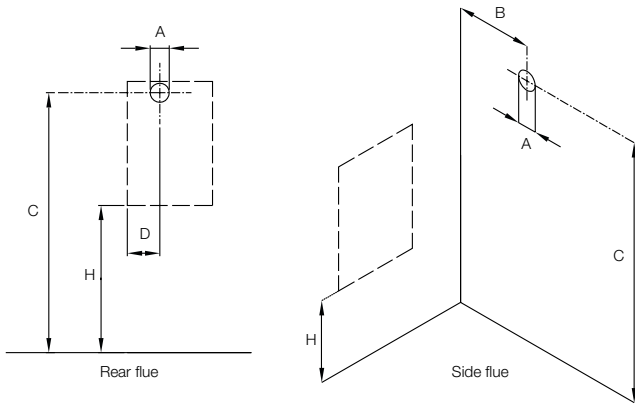

Figure 9-15: Flue hole dimensions and position for low level system

Table 9-16: Low level balanced flue hole cutting dimensions

Dimension (mm)			
A (dia.)	B	C	D
127	110	H + 755*	220

* H is the height from the floor to the underside of boiler casing

! NOTE !

Dimension A given in Figure 9-11 includes an extra 10 mm over the size of the terminal to provide clearance for fitting.

9.5.2 HIGH LEVEL AND VERTICAL BALANCED FLUE

If the boiler is to be used with the high level balanced flue (White system) make the hole in the wall for the flue as shown in Figure 9-17.

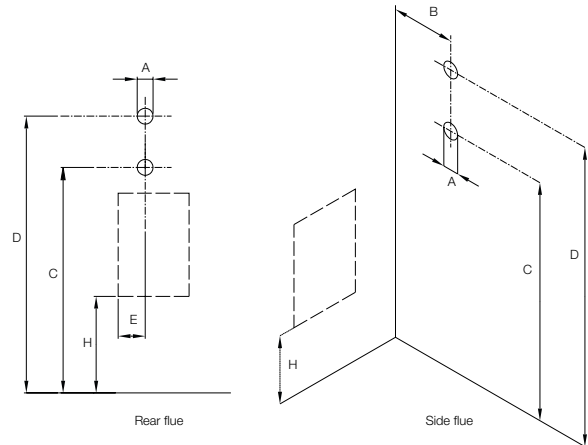

Figure 9-17: Flue hole dimensions and position for high level system

Table 9-18: High level balanced flue hole cutting dimensions

Dimension (mm)					
A (dia.)	B	C min	D min	D max	E
175	110	TBC	TBC	TBC	220

* Dimension C for starter section and elbow/terminal only

! NOTE !

Dimension A given in Figure 9-12 includes an extra 10 mm over the size of the terminal to provide clearance for fitting.

Fitting instructions for the high level balanced flue and vertical balanced flue are supplied with the flue kits.

Adjustable extensions

The adjustable extensions are telescopic.

The wall terminal section is adjustable and is suitable for a wall thickness of 215 mm to 450 mm.

Simply adjust to the required length using a twisting motion. The outer pipes must overlap by a minimum of 25 mm.

9.6 FLUE CLEARANCES

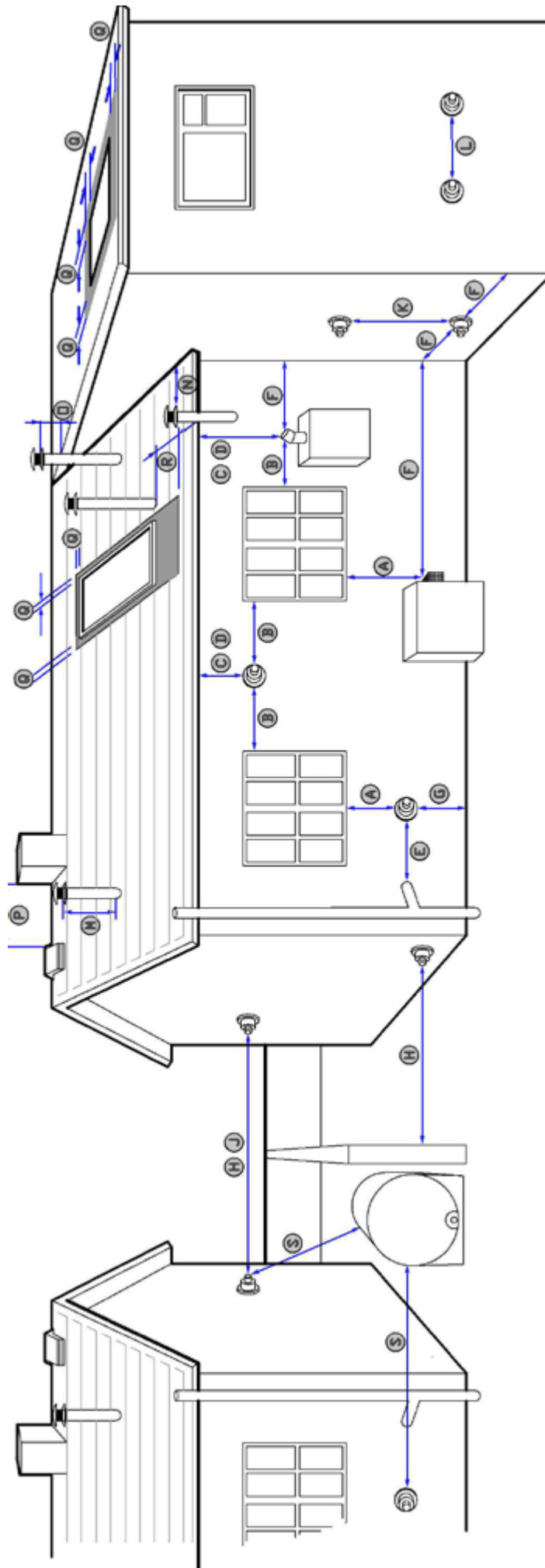

Figure 9-19: Flue clearances

Table 9-20: Flue clearances

Ref	Location of outlet	Minimum distance (mm)	
		Pressure jet	Condensing
A	Directly below an opening, air brick opening, opening window, etc.	600	1,000 **
B	Horizontally to an opening, air brick opening, opening window, etc.	600	1,000 **
C	Below a gutter, eaves or balcony with protection	75 *	1,000 **
D	Below a gutter, eaves or balcony without protection	600	1,000 **
E	From vertical sanitary pipework	300	
F	From an internal or external corner	300	
G	Above ground or balcony level	300	
H	From a surface or boundary facing the terminal	600	2,500 **
J	From a terminal facing the terminal	1,200	
K	Vertically from a terminal on the same wall	1,500	
L	Horizontally from a terminal on the same wall	750	
M	Above the highest point of an intersection with the roof	600	
N	From a vertical structure to the side of the terminal	750	
O	Above a vertical structure less than 750 mm from the side of the terminal	600	
P	From a ridge terminal to a vertical structure on the roof	1,500	
Q	Above or to the side of any opening on a flat or sloping roof	300	
R	Below any opening on a sloping roof	1,000	
S	From oil storage tank (Class 1)	1,800 ***	

* A heat shield at least 750 mm wide must be fitted to provide protection of combustible material.

** Clearances required by BS 5410-1:2014 to alleviate the effect of plume nuisance. If a risk assessment shows that there will be no impact from pluming, then the 'pressure jet' figure could apply - seek confirmation from Local Authority Building Control.

*** Seek guidance from OFTEC Book 3 (Oil Storage and Supply).

NOTES

- Appliances burning class D fuel have additional restrictions. Refer to BS 5410-1:2014.
- Vertical structure in N, O and P includes tank or lift rooms, parapets, dormers, etc.
- Terminating positions A to L are only permitted for appliances that have been approved for low level flue discharge when tested in accordance with BS EN 303-1, OFS A100 or OFS A101.
- Terminating positions should be at least 1.8 metres from an oil storage tank (Class 1) unless a wall with at least 30 minutes fire resistance and extending 300 mm higher and wider than the tank is provided between the tank and the terminating position.
- Where a flue is terminated less than 600 mm away from a projection above it and the projection consists of plastics or has a combustible or painted surface, then a heat shield of at least 750 mm wide should be fitted to protect these surfaces.
- If the lowest part of the terminal is less than 2 metres above the ground, balcony, flat roof or other place to which any person has access, the terminal should be protected by a guard.
- Notwithstanding the dimensions given above, a terminal should not be sited closer than 300 mm to combustible material. In the case of a thatched roof, double this separation distance should be provided. It is also advisable to treat the thatch with a fire retardant material and close wire in the immediate vicinity of the flue.
- A flue or chimney should not pass through the roof within the shaded area delineated by dimensions Q and R.
- Where protection is provided for plastics components, such as guttering, this should be to the standard specified by the manufacturer of the plastics components.
- Terminals must not be sited under car ports.
- Terminals at low levels (terminals under 2.1 metres) have more restrictive recommendations and should not be positioned near public footways, frequently used access routes, car parking spaces less than 2.5 metres from the terminal or patio's (hard surface area).

Further guidance can be obtained from BS 5410-1:2014, OFTEC Book 4 (Installation) and Approved Document J.

Grant UK flue products are fully compliant with the CE (Communauté Européenne/European Community) standards having undergone rigorous product testing.

10 COMMISSIONING

To ensure safe and efficient operation, it is essential that a Grant Eco Wall Hung boiler is commissioned as detailed in the following procedure.

To access the controls, open the lower front panel by pulling it down as shown in Figure 10-1.

The controls are shown in Figure 10-2.

To access the remainder of the boiler, remove the upper front panel. To do this, hold the lower edge of the panel and pull it sharply outwards to disengage the retaining clips and lift off from the boiler.

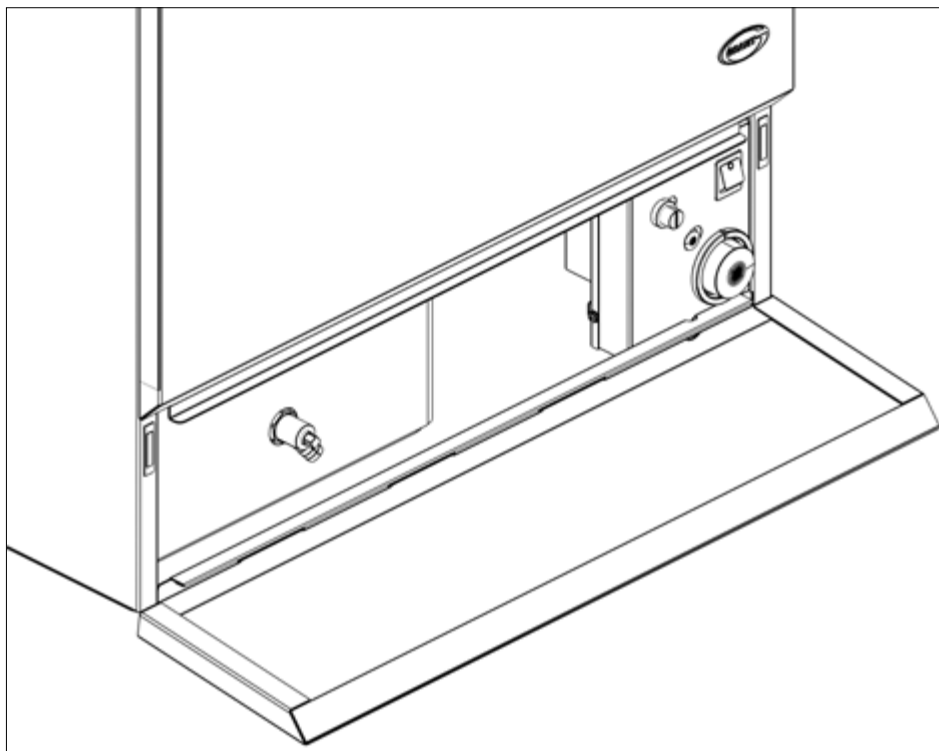

Figure 10-1: Boiler lower front panel in down position



Figure 10-2: Boiler controls

10.1 BEFORE SWITCHING ON

1. Ensure the boiler is isolated from the electrical supply and the boiler On/Off switch is set to OFF.
2. Check that the high limit thermostat bulb and boiler thermostat bulb are correctly located in their respective pockets. Check condition of both thermostat capillaries. Ensure they are not damaged, broken, kinked or crushed.
3. Remove the nuts and washers securing the front cleaning door. Withdraw the door – take care as it is heavy!
4. Check that the turbulators are in position and that the ends are vertical.
5. Check that the baffles are in position. Refer to Figure 11-1.
6. Refit cleaning door and check that it is fitted correctly and that a good seal is made.
7. Slacken of the hose clip and disconnect the flexible air inlet (snorkel) tube from the burner.
8. Unscrew the burner fixing nut (located at the top of the mounting flange), rotate the burner clockwise and remove the burner from the boiler.

The burner has a slotted lug on the underside of the fan housing. This allows the burner, when removed from the boiler, to be hung on the bolt on the front of the combustion door for checking/servicing.

! NOTE !

With two flexible hoses connected to the burner, identify (mark if necessary) which is the inlet and return if they are to be disconnected.

9. Check/adjust the burner settings as described in Section 10.2.
10. Re-fit the burner to the boiler and tighten the fixing nut. DO NOT OVERTIGHTEN!
11. Ensure that the condensing heat exchanger has been vented via the automatic air vent.
12. Ensure the automatic air vent on the condensing heat exchanger is open.
13. Check that all fuel line valves are open.
14. Connect a combined vent manifold and pressure gauge to the pressure gauge connection port on the oil pump. Open the vent screw on the vent manifold to vent the supply while the pump is running.
15. Check that all system controls are calling for heat and turn the boiler thermostat to maximum.

10.2 BURNER SETTINGS

With the burner removed from the boiler:

1. Remove the burner head. Refer to Figure 10-3. Loosen the two fixing screws and remove the head from the burner.

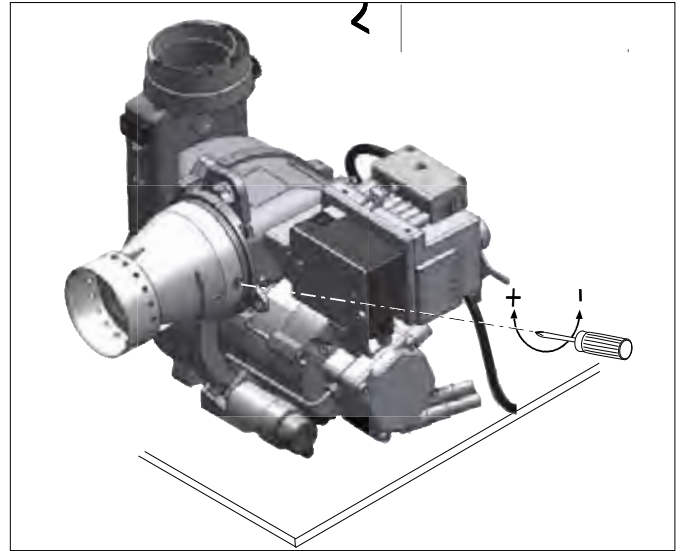

Figure 10-3: Removal of burner head

2. Check the nozzle is correct for the required boiler output. Refer to Table 2-2 for the correct nozzle size and type for the required boiler output.
3. If the nozzle needs to be replaced – remove the diffuser/electrode assembly. Refer to Figure 10-4.
 - Using a 3 mm Allen key, loosen the diffuser fixing screw on the electrode assembly.
 - Lift the diffuser/electrode assembly up and off the nozzle holder.
 - Disconnect both ignition leads from the electrodes.
4. Use a 16mm spanner to remove /re-fit the nozzle, whilst holding the nozzle holder using another 16mm spanner.

! CAUTION !

The use of an ill-fitting spanner will damage the nozzle and could lead to an incorrect flame pattern and poor combustion.

! NOTE !

Ensure that the nozzle is securely tightened so it does not leak but DO NOT OVERTIGHTEN!

5. Re-fit the diffuser/electrode assembly. Refer to Figure 10-4. Re-connect ignition leads to electrodes.
Re-fit the diffuser/electrode assembly onto the nozzle holder lining up the fixing screw with the with the recess in the nozzle holder.
Ensure diffuser assemble is fitted down hard onto the shoulder on the nozzle holder.
Tighten the fixing screw to secure the diffuser/electrode assembly in place on the nozzle holder.

! NOTE !

Do not overtighten the fixing screw as this may damage the electrode insulator.

6. Check/adjust the electrode setting. Refer to Figure 10-4. Always check the electrode settings after replacing the nozzle.

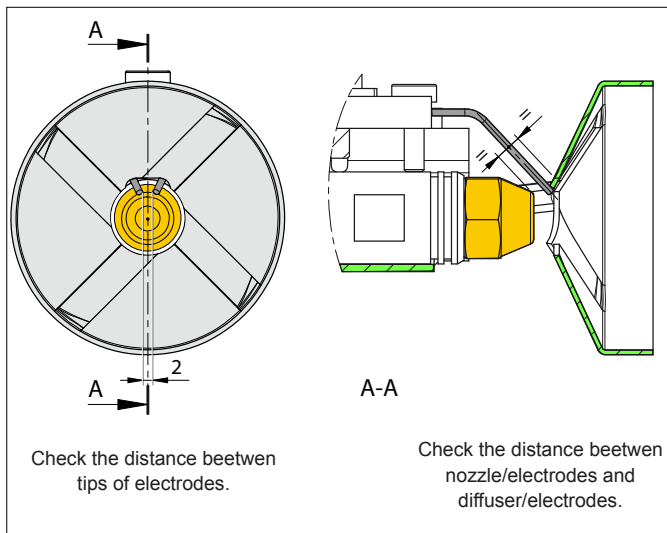

Figure 10-4: Ignition electrode settings

7. Re-fit the burner head. Refer to Figure 10-3.
 - Locate the head fixing screws in the countersunk slots in the burner collar.
 - Check/adjust the electrode setting. Refer to Figure 10-4.
 - As the head will only fit one way, rotate the head until the two screws align with the slots.
 - Tighten the two screws to secure the head in position on the burner.
8. Check/adjust the diffuser position. Refer to Figure 10-4.

! NOTE !

The diffuser position MUST be correctly set for the burner to operate correctly.

The diffuser position is correctly set when the distance between the internal shoulder of the burner head and the face of the nozzle is as given in Table 2-2.

- Refer to Table 2-2 for the required distance (diffuser setting) for the boiler output required. This is the distance from the front face of the nozzle to the internal shoulder of the burner head. Refer to Figure 10-5.
- Check the distance using the gauge supplied with the burner.

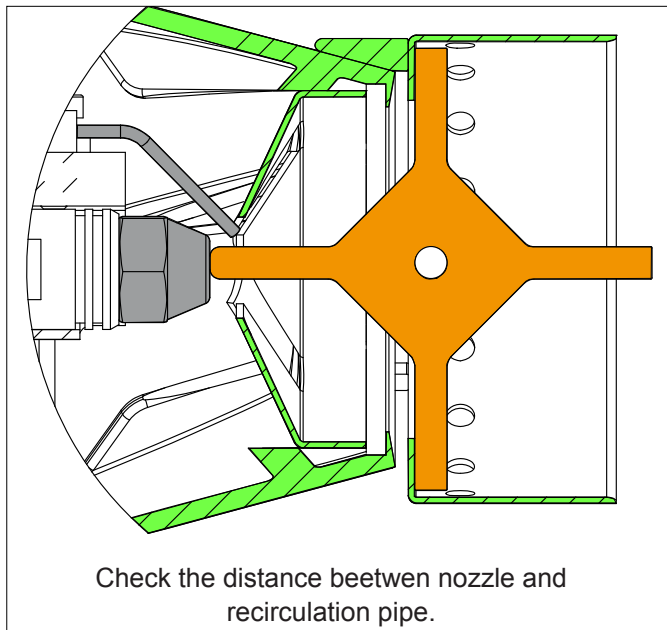

Figure 10-5: Checking the diffuser position using the gauge provided

- The three possible boiler output settings are stamped on three of the legs of the gauge.
- To use the gauge: Identify the correct leg of the gauge that matches the required boiler output.

- Position the gauge on the internal shoulder of the burner head so the leg for the required output is pointing towards the nozzle.
- Check that the gauge is at 90° to the internal shoulder of the burner head and across the full diameter.
- If the diffuser setting is correct, the tip of the gauge leg will just touch the front face of the nozzle, with the gauge still in contact with the internal shoulder of the burner head on BOTH sides. Refer to Figure 10-5.
- If the gauge leg is in contact with the nozzle face but the gauge is NOT in contact with the internal shoulder of the burner head on BOTH sides, the diffuser must be 'opened' (see below).
- If the gauge leg does not reach the nozzle with the gauge is in contact with the internal shoulder of the burner head on BOTH sides, the diffuser must be 'closed' (see below).

To adjust the diffuser position:

- If necessary, adjust the diffuser position by rotating the adjustment screw, located on the front of the burner, using a 4mm Allen key. Refer to Figure 10-3. Re-check the diffuser setting using the gauge, as described above.
- To increase the distance between the nozzle face and internal shoulder of the burner head (to open the diffuser): rotate the adjusting screw clockwise.
- To decrease the distance between the nozzle face and internal shoulder of the burner head (to close the diffuser): rotate the adjusting screw anti-clockwise.

! NOTE !

One full rotation of the adjuster screw is approximately 1mm of diffuser (and nozzle) movement.

! NOTE !

It is essential that the final position of the diffuser is checked, using the gauge provided with the boiler, and the diffuser adjusted as necessary to achieve the required position.

10.3 SWITCHING ON

1. Switch on the electricity supply.
2. Set the boiler On/Off switch to ON. A Neon on the switch lights when it is in the ON position. The boiler will now light automatically. Note that the neon lights when the boiler is switched on, but does not necessarily indicate that the burner is firing.
The burner should then fire. Open the vent screw on the vent manifold to vent the supply while the burner is firing.
3. The burner fan should start and the burner should light within about 12 seconds. If the burner does not light and the 'Lock-out' reset button on the burner lights, wait about 45 seconds and press the reset button to restart the ignition process.
This procedure may have to be repeated several times during first lighting.
4. With the burner alight, check the fuel pressure. Refer to Section 2.3 (burner settings).
5. Adjust the pressure if necessary.

! NOTE !

It is important that the oil pressure is correctly set.

6. Operate the boiler until it reaches normal operating temperature. Check oil supply/return pipe for leaks, rectifying where necessary.
7. Check the operation of the boiler thermostat. Ensure that by turning it anticlockwise it switches the burner off.
8. With the burner alight, re-check the fuel pressure and re-adjust if necessary. Turn the boiler off, remove the pressure

- gauge and replace the plug in the pump.
- Ensure that there are no oil leaks.
 - On balanced flue installations – ensure the flexible air inlet tube and the flexible air tube is connected to both the burner air inlet and the flue system.

10.4 RUNNING THE BOILER

- Re-light the boiler and allow it to run for at least 20 minutes.
- Check the smoke number, if it is 0-1 then it is satisfactory.
- Using a calibrated electronic flue gas analyser, set to the correct fuel, check the %CO₂ in the flue gases.

! NOTE !

To allow the boiler to be commissioned and serviced correctly a combustion test point is provided on the front cleaning door. Both the %CO₂ and smoke test may all be carried out using this test point.

This test point is not suitable for measuring boiler efficiency or conventional flue draught.

When using the test point on the cleaning cover note that the flue gas temperature reading will be higher than that measured in the flue thus resulting in an inaccurate efficiency reading. To obtain an accurate flue gas temperature and efficiency, the reading can only be measured outside through the low level flue terminal (or the test point on the conventional flue started section when used).

For high level and vertical balanced flues, the reading may be taken from the flue test point provided on the flue system. Refer to Section 9.

For conventional flues, a test point is provided in the conventional flue adaptor for flue draught and flue gas temperature measurement. Refer to Section 9.

- Set the %CO₂, as indicated on the flue gas analyser, to the required value given in Section 2.3 for the boiler concerned.
- Adjust the burner air damper by rotating the adjuster knob (see Figure 10-3) to achieve the required %CO₂.
- To increase the %CO₂ :
 - Turn the knob anti-clockwise. This will close the burner air damper and decrease the combustion air entering the burner.

To decrease the %CO₂ :

 - Turn the knob clockwise. This will open the burner air damper and increase the combustion air entering the burner.
- When the %CO₂ is set to the correct level, re-check the smoke number if the damper has been moved. Under no circumstances must the smoke number be above 1.

! NOTE !

For safer and efficient operation of the boiler it is essential that the air damper is correctly set to give the required %CO₂ in the flue gases.

10.5 BALANCING THE SYSTEM

- When the boiler has been adjusted and is running satisfactorily, balance the central heating system by adjusting the radiator lock shield valves.

Start with the radiator nearest the boiler and adjust the valves to achieve the required temperature drop across each radiator. If thermostatic radiator valves have been installed, check the system by-pass.

- Switch off the boiler.

10.6 COMPLETION

- With the system hot, check again for leaks, rectifying where necessary. Drain the system while it is hot to complete the flushing process. Refill and vent (and pressurise if a sealed system) the system.
- A suitable central heating system inhibitor must be added to protect the system against the effects of corrosion.
- A suitable antifreeze should be used to prevent damage to the boiler in areas where the electrical power failure can occur in winter months.
- Replace the upper and lower front panels on the boiler.

! NOTE !

After commissioning the boiler complete the Commissioning Report in the front of this manual and the OFTEC CD/11 commissioning report. Leave the top copy with the User and retain the carbon copy.

If the boiler is to be left in service with the User, set the controls, remote programmer and room thermostat to the User's requirements.

If the boiler is not to be handed over immediately, close the boiler fuel supply valve and switch off the electricity supply.

! CAUTION !

If there is any possibility of the boiler being left during frost conditions, then the boiler and system should be drained. Alternatively, a suitable heating system antifreeze should be used.

11 SERVICING

To ensure efficient operation of the boiler it is essential that a Grant Eco Wall Hung boiler is serviced at regular intervals of no longer than 12 months.

Servicing and replacement of parts must only be carried out by a suitably qualified engineer.

! CAUTION !

Details of every service should be entered in the Service Log, in the Boiler Handbook.

This information may be required to validate the Grant extended guarantee.

! WARNING !

Before starting any work on the boiler, or fuel supply please read the Health and Safety information given in Section 14 of these instructions.

11.1 CHECKS BEFORE SERVICING

The following sequence of checks should be made before starting any servicing work:

1. Check the flue terminal and ensure it is not blocked or damaged.
2. Run the boiler and check the operation of its controls.
3. Ensure that all water system connections and fittings are sound. Remake any joints and check the tightness of any fittings that may be leaking.
4. Allow the boiler and system to cool down.
5. If the boiler is used on a sealed central heating system, check the system pressure, check the operation of the pressure relief valve and check the expansion vessel air charge. Refer to Section 7.
6. Refill, vent and re-pressurise the system as necessary. Refer to Section 7.
7. Check that any ventilation openings are of adequate free area and are clear. Refer to Section 7.
8. Remove any sludge/water from the fuel tank by opening the sludge valve at the lower end of the tank (if fitted).
9. Ensure that all fuel system connections and fittings are sound. Remake any joints and check the tightness of any fittings that may be leaking.
10. With the fuel supply valve (at the oil tank) closed, clean/replace the filter element and clean the filter bowl.

! WARNING !

Before servicing, set the boiler On/Off switch to OFF, isolate the electricity supply and close the fuel supply valve.

The data label on the inside of the case side panel will indicate the fuel used and the nozzle fitted.

11.2 DISMANTLING PRIOR TO SERVICING

The procedure for dismantling the boiler is as follows:

1. Remove the front panels from the boiler.
To remove the lower front panel: open by pulling top edge down, slide panel to left or right and detach from the boiler.
To remove the upper front panel: hold the lower edge of the panel and pull it sharply outwards to disengage the retaining clips and lift off from the boiler.
2. On System models, carefully lift up and remove the expansion vessel from the boiler. Place the vessel on the front of the boiler. A clip is fitted to clip it on to the top front edge of the casing.
3. Slacken of the hose clip and disconnect the flexible air inlet (snorkel) tube from the burner.
4. Unscrew the burner fixing nut (top of mounting flange) and rotate the burner clockwise and withdraw the burner from the boiler.
The burner has a slotted lug on the underside of the fan housing. This allows the burner, when removed from the boiler, to be hung on the bolt on the front of the combustion door for checking/servicing.
5. If required, disconnect the flexible oil line(s), using a suitable container to prevent any oil spillage.
6. Check or replace the flexible fuel supply hose(s), as follows:
 - Braided flexible fuel supply hoses (as supplied with the boiler) should be replaced annually i.e. when the boiler is serviced.
 - Long-life hoses should be inspected annually. If in doubt replaces the hose(s). In any event, these hoses must be replaced every five years.

! NOTE !

With a two-pipe oil supply there will be two flexible hoses connected to the burner. Identify (mark if necessary) which is the inlet and return if they are to be disconnected.

11.3 CLEANING THE BOILER

The procedure for cleaning the boiler is as follows:

1. Remove the nuts and washers securing the front cleaning door and withdraw the door. Take care – it is heavy.
2. Remove the baffles as shown in Figure 11-1.

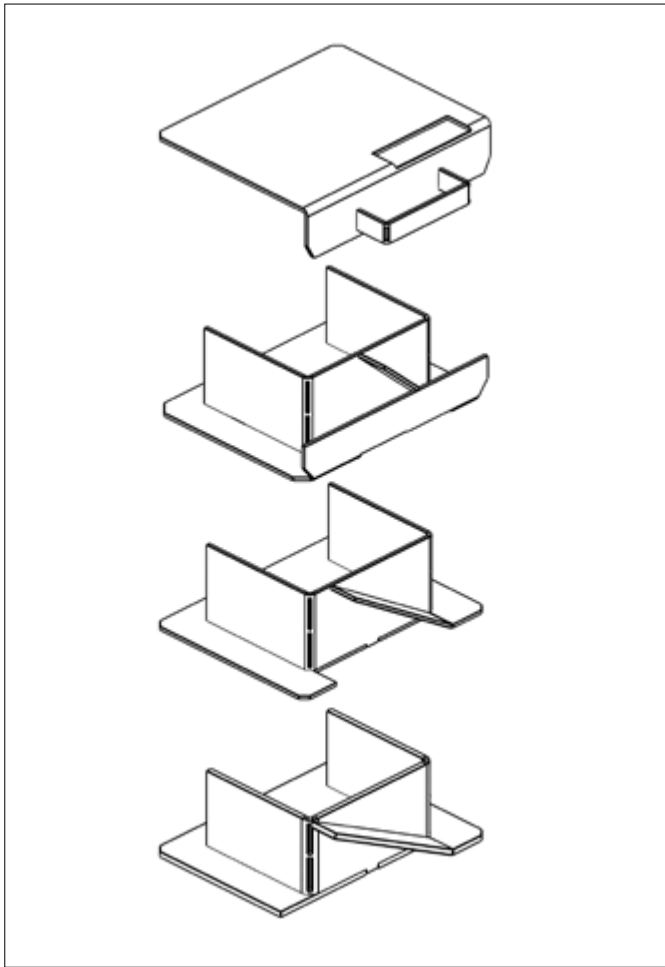

Figure 11-1: Removing the baffles

3. Remove all deposits from the baffle plates and all the boiler internal surfaces using a stiff brush and scraper if necessary.
4. Check the condition of the flue, clean as necessary.
5. Check the condition of the front cleaning door seal and replace if necessary.
6. Replace the baffles, ensuring they are correctly fitted. Refer to Figure 11-1.
7. Pull out the spiral turbulators from the heat exchanger tubes.
8. Clean the turbulators using a stiff brush.
9. Test the heat exchanger condensate drain by pouring water into one of the lower tubes and observe whether the water discharges from the 22mm condensate outlet. Replace the turbulators.
10. Replace the front cleaning door, ensuring the seal is in good condition and secure it in position with the nuts and washers previously removed. Tighten to form a seal.
11. Remove the condensate trap and check that it is not blocked and is operating correctly, i.e. the float is free to move. Clean the trap and float as required. Refer to Section 6.8.
12. Check that the boiler condensate outlet is unobstructed. Clean if necessary.

! NOTE !

The condensate trap and condensate outlet must be checked on every service and cleaned as necessary.

11.4 CLEANING THE BURNER

With the burner removed from the boiler:

1. Remove the burner head. Refer to Figure 10-3. Loosen the two fixing screws and remove the head from the burner.
2. Clean the burner head.
3. Remove the diffuser/electrode assembly. Refer to Figure 10-2.
 - Using a 3mm Allen key, loosen the diffuser fixing screw on the electrode assembly.
 - Lift the diffuser/electrode assembly up and off the nozzle holder.
 - Disconnect both ignition leads from the electrodes.
4. Use a 16 mm spanner to remove/re-fit the nozzle, whilst holding the nozzle holder using another 16 mm spanner.

! CAUTION !

The use of an ill-fitting spanner will damage the nozzle and could lead to an incorrect flame pattern and poor combustion.

5. Inspect the ignition electrodes – remove the electrode fixing screw and withdraw the electrode assembly. Wipe clean and check for any cracks on the insulation. Replace if necessary.
6. Re-fit the diffuser/electrode assembly. Refer to Figure 10-4.
 - Re-connect ignition leads to electrodes.
 - Re-fit the diffuser/electrode assembly onto the nozzle holder lining up the fixing screw with the recess in the nozzle holder.
 - Ensure diffuser assembly is fitted down hard onto the shoulder on the nozzle holder.
 - Tighten the fixing screw to secure the diffuser/electrode assembly in place on the nozzle holder.

! NOTE !

Do not overtighten the fixing screw as this may damage the electrode insulator.

7. Check/adjust the electrode setting. Refer to Figure 10-4. Always check the electrode settings after replacing the nozzle.
8. Re-fit the burner head. Refer to Figure 10-3.
 - Locate the head fixing screws in the countersunk slots in the burner collar.
 - Check/adjust the electrode setting. Refer to Figure 10-3.
 - As the head will only fit one way, rotate the head until the two screws align with the slots.
 - Tighten the two screws to secure the head in position on the burner.
9. Adjust the diffuser position. Refer to Figure 10-5.

! NOTE !

The diffuser position MUST be correctly set for the burner to operate correctly.

The diffuser position is correctly set when the distance between the internal shoulder of the burner head and the face of the nozzle is as given in Table 2-2.

- Refer to Table 2-2 for the required distance (diffuser setting) for the boiler output required. This is the distance from the front face of the nozzle to the internal shoulder of the burner head. Refer to Figure 10-3.
- Check the distance using the gauge supplied with the burner.
- The three possible boiler output settings are stamped on three of the legs of the gauge.
- To use the gauge: Identify the correct leg of the gauge that matches the required boiler output.
- Position the gauge on the internal shoulder of the burner head so the leg for the required output is pointing

towards the nozzle.

- Check that the gauge is at 90° to the internal shoulder of the burner head and across the full diameter.
- If the diffuser setting is correct, the tip of the gauge leg will just touch the front face of the nozzle, with the gauge still in contact with the internal shoulder of the burner head on BOTH sides.
- If the gauge leg is in contact with the nozzle face but the gauge is NOT in contact with the internal shoulder of the burner head on BOTH sides, the diffuser must be 'opened' (see below).
- If the gauge leg does not reach the nozzle with the gauge is in contact with the internal shoulder of the burner head on BOTH sides, the diffuser must be 'closed' (see below).

To adjust the diffuser position:

- If necessary, adjust the diffuser position by rotating the adjustment screw, located on the front of the burner, using a 4mm Allen key. Refer to Figure 10-3. Re-check the diffuser setting using the gauge, as described above.
- To increase the distance between the nozzle face and internal shoulder of the burner head (to open the diffuser): rotate the adjusting screw clockwise.
- To decrease the distance between the nozzle face and internal shoulder of the burner head (to close the diffuser): rotate the adjusting screw anti-clockwise.

! NOTE !

One full rotation of the adjuster screw is approximately 1mm of diffuser (and nozzle) movement.

! NOTE !

It is essential that the final position of the diffuser is checked, using the gauge provided with the boiler, and the diffuser adjusted as necessary to achieve the required position.

10. Continue cleaning the other burner components as detailed in Section 11.5

11.5 CLEANING THE BURNER

The procedure for cleaning the burner is:

Photocell

The photocell is a push-fit in the front of the burner body.

1. Holding the body of the photocell and NOT the cable, carefully pull the photocell out of the burner.
2. Clean the sensor end of the photocell.
3. Replace photocell back in the burner and check that it is fully pushed in.

Burner air inlet

This is located on the right hand side of the burner. Refer to Figure 10-3.

1. Using a 4mm Allen key, unscrew and remove the two screws and remove the air inlet from the burner.
2. Check inside and remove any debris, leaves, hair, fluff, etc. from the air inlet housing and air damper.

Burner fan housing

This is located over the fan impeller. Refer to Figure 10-3.

With the burner air inlet already removed:

1. Using a 4mm Allen key, unscrew and remove the four screws and remove the fan housing from the burner.
2. Check and clean the fan impeller and remove any debris, leaves, hair, fluff, etc.
3. Check/clean the fan housing.
4. Check the rubber seal around the fan housing. Replace if damaged or missing.
5. Re-fit the fan housing to the burner and secure with the four screws.
6. Re-fit the burner air inlet to the burner and secure with the two screws.

Oil pump filter

This is located under the end cover on the oil pump. Refer to Figure 10-3.

1. Using a 4mm Allen key, unscrew and remove the four cap screws securing the pump end cover. Remove end cover from pump.
2. Remove the filter and wash in kerosene.
3. Check the O-ring seal around the end cover. Replace if damaged.
4. Refit the filter and end cover.
5. Re-fit the four cap screws, tighten evenly, to secure the end cover.

11.6 RECOMMISSIONING

! WARNING !

To ensure safe and efficient operation of the boiler it is important that re-commissioning is carried out, especially combustion checks (%CO₂ level, flue gas temperature and smoke number) after the boiler has been serviced. Refer to the Commissioning instructions in Section 10.

12 FAULT FINDING

12.1 BURNER FAULT FINDING CHARTS

12.1.1 BURNER FAILS TO START, NO FLAME, NO LOCK OUT

Symptoms	Possible causes	Actions
Motor fails to run	No electrical supply to boiler	▶ Check ON/OFF switch is ON - mains neon is lit
▼	▼	▼
Lock-out light not lit	Fuse has blown	▶ Check or replace fuse
		▼
		If fuse has blown - check reason for failure
	Boiler thermostat not calling	▶ Adjust boiler thermostat to call for heat
	Heating controls are not calling	▶ Adjust programmer and room thermostat to call
	Overheat thermostat has operated	▶ Check and reset overheat thermostat if required
		▼
		If operated - check reason for operation
	No power to burner	▶ Check for 230 volts at control box mains terminals
	Control box faulty	▶ Replace faulty control box

12.1.2 BURNER FAILS TO START, NO FLAME, GOES TO LOCKOUT

Symptoms	Possible causes	Actions
Motor fails to run	No power to burner motor	▶ Check for 230 volts at motor plug terminals
▼		
Burner lockout	Burner motor capacity faulty	▶ Check and replace if necessary
	Burner motor faulty	▶ Replace burner motor
	Burner motor stalled	
	▼	
	Seized oil pump	▶ Check and replace faulty oil pump

12.1.3 BURNER STARTS, NO FLAME, GOES TO LOCKOUT

Symptoms	Possible causes	Actions
Motor runs	Flame instability	
▼	▼	
Burner pre-purges	Carbon / soot on combustion head	▶ Clean blast tube
▼	▼	
Burner does not fire	No oil pressure	▶ Check pump drive coupling - replace if failed
▼		
Burner lock-out	Low oil pressure	▶ Check oil pump pressure is correct
	▼	
	Excessive combustion air	▶ Adjust air damper setting
	▼	
	Excessive flue draught (CF only)	▶ Rectify condition (is a draught stabiliser required?)
	False light	▶ Check photocell is not sensing ambient light
	No ignition spark	▶ Check HT lead connections are sound ▶ Check ignition electrode gap is correct ▶ Check for 230 volts at ignition transformer ▶ Check transformer - replace if faulty
	No oil at nozzle	▶ Check for sufficient fuel in tank ▶ Check fire valve has not tripped ▶ Check all oil supply valves are open ▶ Check oil line and pump is not air-locked ▶ Check operation of solenoid valve ▶ Check pump drive coupling - replace if failed ▶ Check fuel pump - replace if seized
	Restriction in oil supply	▶ Check filters, valves and oil lines and rectify
	Fuel contamination (water in tank)	▶ Check tank, filters and oil line for water

12.1.4 BURNER FIRES, GOES TO LOCKOUT

Symptoms	Possible causes	Actions
Motor runs	Flame instability	
▼	▼	
Burner pre-purges	Carbon / soot on combustion head	▶ Clean combustion head
▼	▼	
Burner fires	Fuel contamination (water in tank)	▶ Check tank, filters and oil line for water
▼		
Burner lockout	Low oil pressure	▶ Check oil pump pressure and adjust if necessary
	▼	
	Excessive combustion air	▶ Adjust air damper setting
	▼	
	Excessive flue draught (CF only)	▶ Rectify condition (is a draught stabiliser required?)
	Photocell not sensing light	▶ Check photocell is clean and unobstructed
	Photocell failed	▶ Replace faulty photocell
	Defective nozzle	▶ Replace nozzle

12.1.5 DELAYED IGNITION, BURNER STARTS VIOLENTLY

Symptoms	Possible causes	Actions
Burner pulsates on start up	Excessive combustion air	▶ Recommission burner - adjust air setting
	Low oil pressure	▶ Check and recommission burner
	Partially blocked nozzle	▶ Replace nozzle
	Fuel contamination (water in tank)	▶ Check tank, filters and oil line for water
	Fan slipping on shaft	▶ Check and re-tighten
	Pump coupling loose or worn	▶ Check and replace
Burner starts violently	Delayed ignition	▶ Check electrode settings
		Check electrodes for damage
		Check HT lead connections are sound
		Check HT leads for damage or arcing

12.1.6 BURNER CYCLES ON AND OFF

Symptoms	Possible causes	Actions
Burner firing	Restriction in oil supply	▶ Check filters, valves and oil lines and rectify
▼		
Burner stops firing	Fuel contamination (water in tank)	▶ Check tank, filters and oil line for water
▼		
Pre-purge starts	Partially blocked nozzle	▶ Replace nozzle
▼		
Burner fires	Vitiated combustion air (balanced flue only)	▶ Disconnect snorkel tube and check operation
▼		
Burner stops firing		▶ Check flue terminal for obstructions and rectify
		▶ Check flue system for leaks and rectify
		▶ Replace faulty thermostat
	Boiler thermostat hunting	▶

13 SPARE PARTS

This section gives exploded views of the Ecoflam Max 1 low NOx yellow flame burners in the Grant Vortex Eco Wall Hung boilers, and parts lists associated with them.

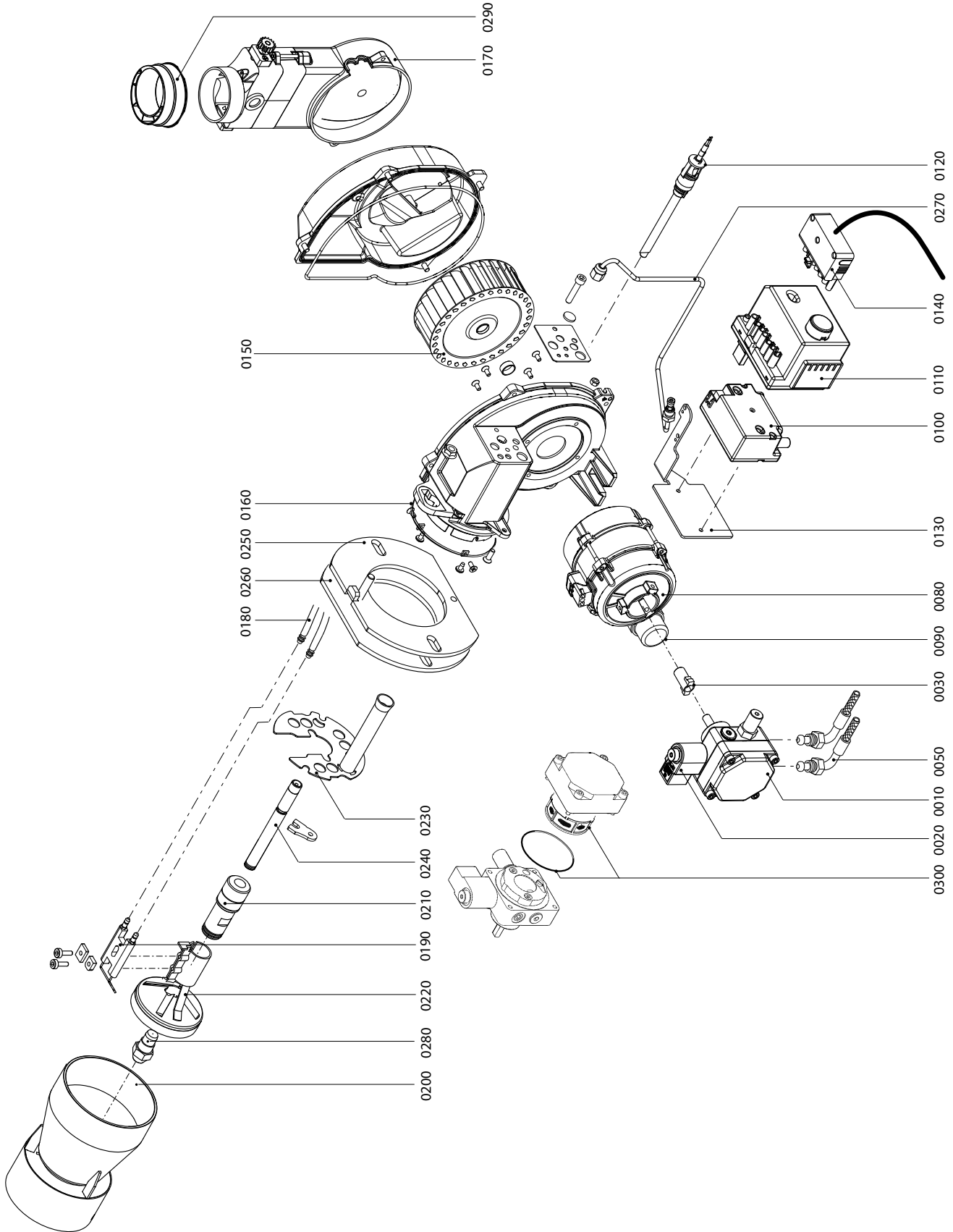

Figure 13-1: Ecoflam Max 1 low NOx yellow flame burner exploded diagram - 15/21, 15/26, 26/36 and 36/46kW models

Figure 13-2: Ecoflam Max 1 low NOx burner parts list

Key No.	12-16	16-21	Description	Ecoflam product code	Grant product code
0010	•	•	Oil pump (Danfoss BFP11 R3)	65322968	EBS65322968
0020	•	•	Coil (Danfoss BFP T85)	65327293	EBS65327293
0030	•	•	Coupling	65322920	EBS65322920
0050	•	•	Hoses	65327402	EBS65327402
0080	•	•	Motor	65326747	EBS65326747
0090	•	•	Capacitor (4 µF)	13011117	EBS13011117
0100	•	•	Ignition transformer	65323257	EBS65323257
0110	•	•	Control box with cables	65327403	EBS65327403
0120	•	•	Photoresistor	65327404	EBS65327404
0130	•	•	Support	65327405	EBS65327405
0140	•	•	Plug and cable	65327406	EBS65327406
0150	•	•	Fan	65323826	EBS65323826
0160	•	•	O-ring	65321066	EBS65321066
0170	•	•	Cover air inlet	65327407	EBS65327407
0180	•	•	Cables	65320934	EBS65320934
0190	•	•	Electrodes	65327306	EBS65327306
0200	•	•	Combustion head (12-16)	65327408	EBS65327408
0210	•	•	Combustion head (16-21)	65327409	EBS65327409
0220	•	•	Nozzle holder	65327410	EBS65327410
	•	•	Diffuser (12-16)	65327411	EBS65327411
	•	•	Diffuser (16-21)	65327412	EBS65327412
0230	•	•	Conveyor	65327413	EBS65327413
0240	•	•	Rod	65327414	EBS65327414
0250	•	•	Flange	65320975	EBS65320975
0260	•	•	Gasket	65321089	EBS65321089
0270	•	•	Oil pipe	65327415	EBS65327415
	•	•	Nozzle - 0.40/80°S	-	M1BS27100
0280	•	•	Nozzle - 0.40/80°EH	-	M1BS27150
	•	•	Nozzle - 0.50/80°EH	-	M1BS27146
	•	•	Nozzle - 0.60/80°EH	-	M1BS27131
0290	•	•	Ring	65320513	EBS65320513
0300	•	•	Set filter and seal	65325684	EBS65325684

14 DECLARATION OF CONFORMITY

EC DECLARATION OF CONFORMITY

In accordance with BS EN ISO/IEC 17050-1:2004

We: Grant Engineering (UK) Limited

Of: Hopton House
Hopton Industrial Estate
Devizes
SN10 2EU

Telephone: +44 (0)1380 736920

Fax: +44 (0)1380 736991

Email: info@grantuk.com

Website: www.grantuk.com

Declare that:

Equipment: Domestic oil boilers

Model Name/Number: Grant Vortex Eco Wall Hung 12-16 and 16-21

Indoor

Grant Vortex Eco Wall Hung System 12-16 and 16-21

Indoor

Note: All Grant system variants are supplied with glandless high efficiency integrated circulators

In accordance with the following Directives:

2006/95/EEC

Conforms with the safety objectives of the Low Voltage Directive and its amending directives.

2004/108/EC

Conforms with the essential protection requirements of the Electromagnetic Compatibility Directive and its amending directives.

92/42/EC

Conforms with the requirements of the Boiler Efficiency Directive.

2010/30/EU

Conforms with the Labeling of Energy related products to EU (no) 811/2013

2009/125/EC

Conforms with the Ecodesign of Energy related products to EU (no) 813/2013

I hereby declare that the equipment named above has been tested and found to comply with the relevant sections of the above referenced specifications. The unit complies with all essential requirements of the Directives.

Responsible Person:

Neil Sawers

Position:

Technical Manager

Signature:



Date:

23rd September 2016

15 HEALTH AND SAFETY INFORMATION

Under the Consumer Protection Act 1987 and Section 6 of the Health & Safety at Work Act 1974, we are required to provide information on substances hazardous to health (COSHH Regulations 1988).

Adhesives, sealants and paints used in the manufacture of the product are cured and present no known hazards when used in the manner for which they are intended.

The following other materials are present in the product:

15.1 INSULATION MATERIALS

Material Types:

Ceramic fibre board, mineral wool.

Description:

Rigid board, slabs, sleeves, gaskets, ropes.

Known Hazards:

May cause temporary irritation or rash to skin. High dust levels may irritate eyes and upper respiratory system.

Precautions:

Avoid unnecessary or rough handling, or harsh abrasion of boards. Normal handling and use of material should not produce high dust levels.

Avoid inhalation, and contact with skin and eyes.

After handling always follow normal good hygiene practices.

Protection:

Use disposable gloves, face mask and eye protection.

First Aid:

Eyes - If irritation occurs, wash eyes with copious amounts of water.

If symptoms persist, seek immediate medical advice.

Skin

If irritation occurs, wash under running water before washing with soap and water.

Inhalation

Remove to fresh air, drink water to clear throat and blow nose to remove dust/fibres.

Ingestion

Drink plenty of water.

15.2 SEALANT AND ADHESIVE

Material Types:

Silicone elastomer.

Description:

Sealant and adhesive.

Known Hazards:

Irritation to eyes.

Precautions:

Avoid inhalation of vapour, contact with eyes and prolonged or repeated contact with skin.

After handling always follow normal good hygiene practices.

Protection:

Use eye protection. Rubber or plastic gloves should be worn where repeated contact occurs and a face mask worn when working in confined spaces.

First Aid:

Eyes

Flush eyes with water for 15 minutes. Seek immediate medical attention.

Skin

Wipe off and wash with soap and water.

Inhalation

Remove to fresh air.

15.3 KEROSENE AND GAS OIL FUELS (MINERAL OILS)

Known Hazards:

The effect of mineral oils on the skin vary according to the duration of exposure and the type of oil.

The lighter fractions remove the protective grease naturally present on the skin, leaving it dry, liable to crack and more prone to damage by cuts, abrasions and irritant chemicals.

Skin rashes (Oil acne) most often on arms, but also on any part of the body in contact with oil or oily clothing.

Contact with fuel oils can cause dermatitis.

Precautions:

Avoid as far as possible any skin contact with mineral oil or with clothing contaminated with mineral oil.

The use of a lanolin-based barrier cream is recommended, in conjunction with regular washing with soap and rinsing with water to ensure all oil is removed from the skin.

Take care to prevent clothing, especially underwear, from becoming contaminated with oil.

Do not put oily rags or tools in pockets, especially trouser pockets.

Have first-aid treatment at once for an injury, however slight.

Do not inhale any vapours from mineral oils.

16 END OF LIFE INFORMATION

GENERAL

Grant oil boilers incorporate components manufactured from a variety of different materials. The majority of these materials can be recycled whilst the smaller remainder cannot.

Materials that cannot be recycled must be disposed of according to local regulations using appropriate waste collection and/or disposal services.

DISASSEMBLY

There is little risk to those involved in the disassembly of this product. Please refer to and follow the Health and Safety Information given in the Installation & Servicing Instructions provided with the boiler.

For guidance on the disassembly of the boiler refer to the information given in the Servicing section of the Installation & Servicing Instructions provided with the boiler.

RECYCLING

Many of the materials used in Grant oil boilers can be recycled, these are listed in the table below:

COMPONENT	MATERIAL
Outer casing panels	Mild steel (polyester powder coated)
Primary heat exchanger and baffles	Mild steel
Secondary heat exchanger	Stainless steel
Secondary heat exchanger spirals	Aluminium alloy
Pipework	Copper
Burner body/flange	Aluminium alloy
Burner oil pump	Aluminium alloy/steel
Riello oil burner cover	Plastic
Electrical wiring	Copper/plastic
Thermostats	Copper/plastic
Printed Circuit boards	Copper/plastic

DISPOSAL

All materials other than those listed above must be disposed of responsibly as general waste.



Neil Sawers
Technical Manager

Grant Oil Boiler Fiche V1.9 21/02/2017

17 PRODUCT FICHE

Product fiche concerning the
 COMMISSION DELEGATED REGULATIONS
 (EU) No 811/2013 of 18 February 2013
 (EU) No 813/2013 of 2 August 2013

Vortex Pro Utility	Symbols	Unit	12-16	16-21	System 12-16	System 16-21
Condensing boiler			Yes	Yes	Yes	Yes
Low temperature boiler			No	No	No	No
B1 boiler			No	No	No	No
Combination heater			No	No	No	No
Rated heat output	Prated	KW	16	21	16	21
Useful heat output						
At rated heat output and high temperature regime	P_4	KW	16	21	16	21
At 30% of rated heat output and low temperature regime	P_1	KW	4.8	6.3	4.8	6.3
Auxiliary electricity consumption						
At full load	elmax	kW	0.164	0.150	0.164	0.150
At part load	elmin	kW	0.062	0.07	0.062	0.07
In standby mode	P_{SB}	kW	0	0	0	0
Useful efficiency						
Seasonal space heating energy efficiency	η_s	%	90.13	90.52	90.13	90.52
At rated heat output and high temperature regime	η_4	%	93.1	90.8	93.1	90.8
At 30% of rated heat output and low temperature regime	η_1	%	96.7	96.9	96.7	96.9
Other items						
Standby heat loss	P_{stby}	kW	0.207	0.236	0.207	0.236
Ignition burner power consumption	P_{ign}	kW	0	0	0	0
Annual energy consumption	Q_{HE}	kWh	-	-	-	-
Sound power level indoors	L_{WA}	dB	51.2	51.7	51.2	51.7
Emissions of nitrogen oxides	NO_x	mg/ kWh	<120	<120	<120	<120
Emission class			2	2	2	2
Daily fuel consumption	Q_{fuel}	kWh	-	-	-	-
Annual fuel consumption	AFC	GJ	-	-	-	-

18 GUARANTEE

You are now the proud owner of a Grant Vortex condensing boiler from Grant Engineering (UK) Limited which has been designed to give years of reliable, trouble free operation.

Grant Engineering (UK) Limited guarantees the manufacture of the boiler including all electrical and mechanical components for a period of **twelve months from the date of installation**⁴, provided that the boiler has been installed in full accordance with the installation and servicing instructions issued.

This will be extended to a total period of **two years** if the boiler is registered with Grant Engineering (UK) Limited within **thirty days of installation** and it is serviced at twelve month intervals³. See main Terms and Conditions below.

If the boiler is installed as part of a VortexAir (hybrid) installation, the guarantee for the boiler will start from its original date of installation and NOT from the date of installation of the heat pump (if installed on different dates).

Registering the product with Grant Engineering (UK) Limited

Please register your Grant Vortex condensing boiler with Grant Engineering UK Limited **within thirty days of installation**. To do so visit:

www.grantuk.com/support/product-registration

You can register your boiler for a further **twelve months** guarantee (giving **two years** from the date of installation⁴). This does not affect your statutory rights¹.

If a fault or defect occurs within the manufacturer's guarantee period

If your boiler should fail within the guarantee period, you must contact Grant Engineering (UK) Limited who will arrange for the repair under the terms of the guarantee, providing that the boiler has been correctly installed, commissioned and serviced (if the appliance has been installed for more than twelve months) by a competent person and the fault is not due to tampering, running out of oil, oil contamination, debris, system water contamination, misuse, trapped air or the failure of any external components not supplied by Grant Engineering (UK) Limited, e.g. fire valve, motorised valve, etc.

This two year guarantee only applies if the boiler is registered with Grant Engineering (UK) Limited within thirty days of installation⁴ and is serviced after twelve months³.

In the first instance

Contact your installer or commissioning engineer to ensure that the fault does not lie with the system components or any incorrect setting of the system controls that falls outside of the manufacturer's guarantee otherwise a service charge could result. Grant Engineering (UK) Limited will not be liable for any charges arising from this process.

If a fault covered by the manufacturer's guarantee is found

Ask your installer to contact Grant Engineering (UK) Limited Service Department on +44 (0)1380 736920 who will arrange for a competent service engineer to rectify the fault.

Remember - before you contact Grant Engineering (UK) Limited

- Ensure the boiler has been installed, commissioned and serviced by a competent person in accordance with the installation and servicing instructions.
- Ensure there is oil to supply the burner.
- Ensure the problem is not being caused by the heating system or its controls. Consult the boiler handbook for guidance.

Free of charge repairs

During the **two year** guarantee period no charge for parts or labour will be made provided that the boiler has been installed and commissioned correctly in accordance with the manufacturer's installation and servicing instructions, it was registered with Grant Engineering (UK) Limited within thirty days of installation⁴ and, for boilers over twelve months old, details of annual service is available³.

The following documents must be made available to Grant Engineering (UK) Limited on request:

- Proof of purchase
- CD10 Installation Completion Form (or equivalent document)
- CD11 Commissioning Report Form (or equivalent document)
- Service documents (CD11 or equivalent document)

Chargeable repairs

A charge may be made (if necessary following testing of parts) if the breakdown is due to any fault(s) caused by the plumbing or heating system, e.g. contamination of parts due to system contamination, sludge, scale, debris or trapped air. Refer to 'Extent of manufacturer's guarantee'.

Extent of manufacturer's guarantee

The manufacturer's guarantee does NOT cover the following:

- If the boiler has been installed for over **two years**.
- If the boiler has not been installed, commissioned, or serviced by a competent person in accordance with the installation and servicing instructions.
- Instances where the serial number has been removed or made illegible.
- Fault(s) due to accidental damage, tampering, unauthorised adjustment, neglect, misuse or operating the boiler contrary to the manufacturer's installation and servicing instructions.
- Damage due to external causes such as bad weather conditions (flood, storms, lightning, frost, snow, or ice), fire, explosion, accident or theft.
- Fault(s) due to incorrectly sized expansion vessel(s), incorrect vessel charge pressure or inadequate expansion on the system.
- Fault(s) caused by external electrics and external components not supplied by Grant Engineering (UK) Limited.
- Problems caused by lack of oil or faults with the oil storage and supply system.
- Fault(s) due to contamination of the oil storage and supply system, e.g. water or debris.
- Bleeding or removing oil storage tank contamination or blockages from oil lines.
- Problems due to the flue system being incorrectly fitted or not installed to meet installation requirements.
- Boiler servicing, de-scaling or flushing.
- Cleaning out condensate traps/discharge pipes or thawing out frozen condensate pipework.
- Checking and replenishing system pressure.
- Oil supply pipelines, electrical cables and plugs, external controls not supplied by Grant Engineering (UK) Limited.
- Heating system components, such as radiators, pipes, fittings, pumps and valves not supplied by Grant Engineering (UK) Limited.
- Instances where the oil boiler has been un-installed and re-installed in another location.
- Use of spare parts not authorised by Grant Engineering (UK) Limited.
- Consumable items including, but not limited to, oil nozzles, oil hoses, gaskets and seals.

IMPORTANT

The nozzle and braided oil hose supplied with the boiler are only covered for the period up to the time of the first service (twelve months). Both **must** be changed on the first service and on every annual service thereafter.

IMPORTANT

A suitable oil filter with a minimum 15µ filtration **must** be installed in the oil supply line.

Do not wait until the fuel supply runs out before you re-order. Sludge in the bottom of the tank may be drawn into the fuel lines. It is recommended that the boiler is switched off when the new oil supply is delivered and that the fuel is allowed to settle for an hour before restarting the boiler.

Terms of manufacturer's guarantee

- The Company shall mean Grant Engineering (UK) Limited.
- The boiler must be installed by a competent person and in full accordance with the relevant Codes of Practice, Regulations and Legislation in force at the time of installation.
- The boiler is guaranteed for **two years** from the date of installation⁴, providing that every twelve months the annual service has been completed³ and the boiler registered with the Company within thirty days of installation. Any work undertaken must be authorised by the Company and carried out by a competent service engineer.
- This guarantee will be invalid if the boiler does not have an annual (every twelve month) service and will then be limited to twelve months from the date of installation⁴.
- The shell (heat exchanger) of the oil boiler is covered by a **five year parts only** guarantee from the date of installation⁴. This is subject to the following:
 - The boiler is operated correctly, in accordance with the Installation and servicing instructions.
 - Grant Engineering (UK) Limited **strongly recommends** that a Grant Mag-One in-line magnetic filter/s (or equivalent⁵) is fitted in the heating system pipework. This should be installed and regularly serviced in accordance with the filter manufacturer's instructions. We reserve the right to ask for proof of installation – failure to provide this may result in the guarantee becoming invalid.
 - Proof is provided that the system has been flushed or chemically cleaned where appropriate (refer to BS 7593) and that the required quantity of a suitable corrosion inhibitor added.
 - Proof of annual servicing (including the checking of any expansion vessels and pressure relief valves) must be provided if and when requested by the Company.
- This guarantee does not cover breakdowns caused by incorrect installation, neglect, misuse, accident or failure to operate the boiler in accordance with the manufacturer's installation and servicing instructions.
- The boiler is registered with the Company within thirty days of installation. Failure to do so does not affect your statutory rights¹.
- The balance of the guarantee is transferable providing the installation is serviced prior to the dwelling's new owners taking up residence. Grant Engineering (UK) Limited must be informed of the new owner's details.
- The Company will endeavour to provide prompt service in the unlikely event of a problem occurring, but cannot be held responsible for any consequences of delay however caused.
- This guarantee applies to Grant Engineering (UK) Limited boilers purchased and installed on the UK mainland, Isle of Wight, Channel Islands and Scottish Isles only². Provision of in-guarantee cover elsewhere in the UK is subject to agreement with the Company.
- All claims under this guarantee must be made to the Company prior to any work being undertaken. Invoices for call out/repair work by any third party will not be accepted unless previously authorised by the Company.
- Proof of purchase and date of installation, commissioning and service documents must be provided on request.
- If a replacement boiler is supplied under the guarantee (due to a manufacturing fault) the product guarantee continues

from the installation date of the original boiler and **not** from the installation date of the replacement⁴.

- The oil boiler must be connected to a mains water supply (installations utilising a private water supply are not covered by this guarantee).
- Breakdown/failure due to lime scale will not be covered by this guarantee.
- The replacement of a boiler under this guarantee does not include any consequential costs, such as the removal or replacement of worktops, kitchen units, etc.
- The boiler (excluding external modules) must not be sited in a location where it may be subjected to frost.

Hard water advice (for Combi boilers only)

If you live in a hard water area, protection against scaling must be given to the domestic hot water heat exchanger of your combination boiler.

You should fit an appropriate scale inhibitor or water softener as any breakdown caused by water scaling is not covered by the manufacturer's guarantee. Ask your installer for advice.

Foot notes

1. Your statutory rights entitle you to a one year guarantee period only.
2. The UK mainland consists of England, Scotland and Wales only. Please note that for the purposes of this definition, Northern Ireland, Isle of Man and Scilly Isles are **not** considered part of the UK mainland.
3. We recommend that your oil boiler is serviced every twelve months (even when the guarantee has expired) to prolong the lifespan and ensure it is operating safely and efficiently.
4. The guarantee period will commence from the date of installation, unless the installation date is more than six months from the date of purchase, in which case the guarantee period will commence six months from the date of purchase.
5. As measured by gauss. The MagOne magnetic filter has a gauss measurement of 12,000.

Version 1.2 – February 2017



GRANT ENGINEERING (UK) LIMITED

Hopton House, Hopton Industrial Estate, Devizes, Wiltshire, SN10 2EU
Tel: +44 (0)1380 736920 Fax: +44 (0)1380 736991
Email: info@grantuk.com www.grantuk.com