

Instructions for Use Installation and Servicing

Models covered by these instructions

(41-260-10)Eden Sb



To be left with the user

High Efficiency Condensing System Boiler



This is a Cat I_{2H} Appliance

Reference in these instructions to British Standards and Statutory Regulations/Requirements apply only to the United Kingdom.

For Ireland the current edition of I.S.813 "Domestic Gas Installations" must be used.

11687

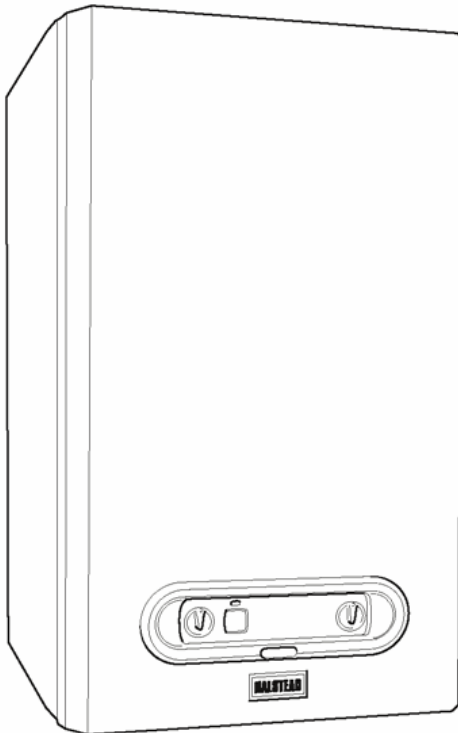

The instructions consist of three parts, User, Installation and Servicing Instructions, which includes the Guarantee Registration Card. The instructions are an integral part of the appliance and must, to comply with the current issue of the Gas Safety (Installation and Use) Regulations, be handed to the user on completion of the installation.

Halstead Boilers Limited, 20/22 First Avenue, Bluebridge Industrial Estate, Halstead, Essex CO9 2EX

Tel: 01787 272800. Sales Direct Line: 01787 475557. Fax: 01787 474588. Service Helpline: 01926 834834.

e-mail: sales@halsteadboilers.co.uk or service@halsteadboilers.co.uk Website : www.halsteadboilers.co.uk

Important Information

General

This condensing system boiler is able to provide central heating from a sealed water system with a fully indirect cylinder. The central heating water temperature can be adjusted on the boiler.

Once the controls are set the boiler operates automatically.

A frost protection program is also included.

Please read these instructions and follow them carefully for the correct and economical use of your boiler.

Gas Category

This boiler is for use only on Natural Gas (G20).

Gas Safety (Installation and Use) Regulations

In your own interests and that of safety, it is the Law that ALL gas appliances are installed by a competent person in accordance with the current issue of the above regulations.

Gas Testing and Certification

The boiler is tested and certificated for safety and performance. It is, therefore, important that no alteration is made to the boiler unless approved, in writing, by Halstead Boilers Ltd.

Any alteration not approved by Halstead Boilers Ltd., could invalidate the certification, boiler warranty and may also infringe the current issue of the statutory requirements.

CE Mark

This boiler meets the requirements of Statutory Instrument, No. 3083 The Boiler (Efficiency) Regulations, and therefore is deemed to meet the requirements of Directive 92/42/EEC on the efficiency requirements for new hot water boilers fired with liquid or gaseous fuels.

Type test for purposes of Regulation 5 certified by: Notified body 0086.

Product/production certified by: Notified body 0086.

The CE mark on this appliance shows compliance with:

1. Directive 90/396/EEC on the approximation of the laws of the Member States relating to appliances burning gaseous fuels.
2. Directive 73/23/EEC on the harmonisation of the Laws of the Member States relating to electrical equipment designed for use within certain voltage limits.
3. Directive 89/336/EEC on the approximation of the Laws of the Member States relating to electromagnetic compatibility.

Control of Substances Hazardous to Health

Under Section 6 of The Health and Safety at Work Act 1974, we are required to provide information on substances hazardous to health.

The adhesives and sealants used in this appliance are cured and give no known hazard in this state.

Insulation Pads.

These can cause irritation to skin, eyes and the respiratory tract.

If you have a history of skin complaint you may be susceptible to irritation. High dust levels are usual only if the material is broken.

Normal handling should not cause discomfort, but follow normal good hygiene and wash your hands before eating, drinking or going to the lavatory.

If you do suffer irritation to the eyes or severe irritation to the skin seek medical attention.

Spare Parts

REMEMBER, When replacing a part on this appliance, use only spare parts that you can be assured conform to the safety and performance specification that we require. Do not use reconditioned or copy parts that have not been clearly authorised by Halstead Boilers Ltd.

Manual Handling Guidance

During the appliance installation and the replacement of the heat exchanger it will be necessary to employ caution and assistance whilst lifting as the appliance or component exceeds the recommended weight for a one man lift.

In certain situations it may be required to use a mechanical handling aid.

Take care to avoid trip hazards, slippery or wet surfaces.

CONTENTS	DESCRIPTION	SECTION
INSTRUCTIONS FOR USE	Important Information	
	Operating the Boiler	
	General Information	1
	Boiler Location and Ventilation	2
	Flue Location and Ventilation	3
INSTALLATION INSTRUCTIONS	Heating System	4
	Domestic Hot Water System	5
	Installation Preparation	6
	Flue Preparation	7
	Gas/Water Connections and Boiler Fixing	8
	Safety Valve Discharge and Condensate Connections	9
	Electrical Connections	10
SERVICING INSTRUCTIONS	Commissioning	11
	Servicing	12
	Fault Finding	13
	Replacement of Parts	14
	Spare Parts	15

Important Information

WARNINGS

Gas Leak or Fault

If a gas leak or fault exists or is suspected, turn the boiler mains electrical supply off and turn off the gas supply at the meter. Consult your local gas company or your local installation/servicing company.

Clearances

If fixtures are positioned close to the boiler, space must be left as shown in [diagram 2.1](#). Enough space must also be left in front of the boiler to allow for servicing.

Sheet Metal Parts

This boiler contains metal parts (components) and care should be taken when handling and cleaning, with particular regard to edges.

Sealed Components

Under no circumstances must the User interfere with any sealed component as this could result in a potentially dangerous situation arising.

Electrical Supply Failure

This boiler must be earthed.

The boiler will not work without an electrical supply.

Normal operation of the boiler should resume when the electrical supply is restored.

Reset any external controls, to resume normal operation of the central heating.

If the boiler does not resume normal operation turn the mains reset switch off and on. If the boiler does not resume normal operation after this the overheat stat may have operated. The overheat stat would only operate under abnormal conditions and, under these circumstances; it would be advisable to consult your installation/servicing company.

Protection Against Freezing

The boiler has a built in frost protection programme as long as the electricity and gas are left switched on.

This device operates the burner and system pump when the temperature inside the boiler falls to 3°C.

Any other exposed areas of the system should be protected by a separate frost thermostat.

If the mains electricity and gas are to be turned off for any long periods during severe weather, it is recommended that the whole system, including the boiler, should be drained to avoid the risk of freezing. Make sure that, if fitted, the immersion heater in the cylinder is switched off.

If you have a sealed water system contact your installation/servicing company as draining, refilling and pressurising MUST be carried out by a competent person.

As a safety feature the boiler will stop working if the condensate drain becomes blocked. During freezing conditions this may be due to the forming of ice in the condensate drain external to the house. Release an ice blockage by the use of warm cloths on the pipe. The boiler should then restart. Contact your installation/servicing company if the fault persists.

Boilers Installed in a Compartment or Cupboard

If the boiler is fitted into a compartment or cupboard it does not require ventilation openings.

Do not use the compartment or cupboard for storage.

Boiler Casing

Do not remove or adjust the casing in any way, as incorrect fitting may result in incorrect operation or failure to operate at all.

Condensate Drain

The condensate drain, see [section 9.2](#), must not be modified or blocked.

Plumbing from flue terminal

Like all condensing boilers this appliance will produce a plume of water vapour from the flue terminal in cool weather. This is due to the high efficiency and hence low flue gas temperature of the boiler. It is normal and not a fault indication.

Cleaning

This appliance contains metal parts and care should be taken when handling and cleaning with particular regard to edges.

The boiler casing can be cleaned using a mild liquid detergent with a damp cloth, then a dry cloth to polish.

Do not use any form of abrasive or solvent cleaner as you may damage the paintwork.

Maintenance and Servicing

For the continued efficient and safe operation of the boiler it is recommended that it is checked and serviced at regular intervals. The frequency of servicing will depend upon the installation conditions and usage, but in general, once a year should be enough.

If this appliance is installed in a rented property in the UK there is a duty of care imposed on the owner of the property by the current issue of the Gas Safety (Installation and Use) Regulations, Section 35.

Servicing/maintenance should be carried out by a competent person in accordance with the rules in force in the countries of destination.

To obtain service, please call your installer or Halstead Boilers using the telephone number on the front cover of this booklet.

Please be advised that the installation engineer on completion of commissioning and servicing should complete the 'Benchmark' logbook.

All CORGI Registered Installers carry a CORGI ID card, and have a registration number. Both should be recorded in your boiler Logbook. You can check your installer is CORGI registered by calling CORGI direct on: - 01256 372300.

Replacement Parts

If replacement parts are required contact Halstead Boilers using the telephone number on the front cover of this booklet.

Please quote the name of the appliance, this information will be on the name badge on the front of the appliance.

If in doubt seek advice from the local gas company or Halstead Boilers using the telephone number on the front cover of this booklet.

Operating the Boiler

To Operate the Boiler

Sealed Water Systems.

CAUTION:

A sealed water system must be filled and pressurised by a competent person.

Only light the boiler when you are sure that the system and boiler have been filled and pressurised.

The pressure should read at least 0.7 bar, anything less than this figure could indicate a leak and you MUST contact your installation/servicing company.

All Systems

Check that the electrical supply to the boiler is ON at the external isolator.

Set any remote controls as required.

User Controls

Turn the mains reset switch to the ON position. The control light will illuminate (green) indicating the boiler is lit, see [diagram 1](#).

The temperature of the central heating water can be adjusted by turning the water temperature control knob to desired setting between 'Min' and 'Max', see [diagram 1](#).

'Max' is approximately 82°C (180°F).

NOTE:

If the appliance is supplying DHW via a storage cylinder, the flow temperature should be set at a temperature high enough to satisfy the DHW demand temperature, for example 50 - 60°C

The digital display, see [diagram 1](#), shows the temperature of the appliance when the appliance is running and system pressure in standby.

A fault is indicated by a RED flashing control light and flash fault code on digital display.

To reset:

Turn the mains reset switch anti-clockwise to 0.

Wait for 5 seconds.

Turn mains reset switch clockwise to 1.

If the fault persists contact your installer/service provider.

It should be noted that this is a fan flue appliance and fan operation may be heard.

To Turn the Boiler Off

There is a mains reset switch on the right hand side of the controls fascia. However, it is preferable to leave the electrical supply on whenever possible to permit operation of the built-in frost protection and daily pump exercise.

Diagram 1

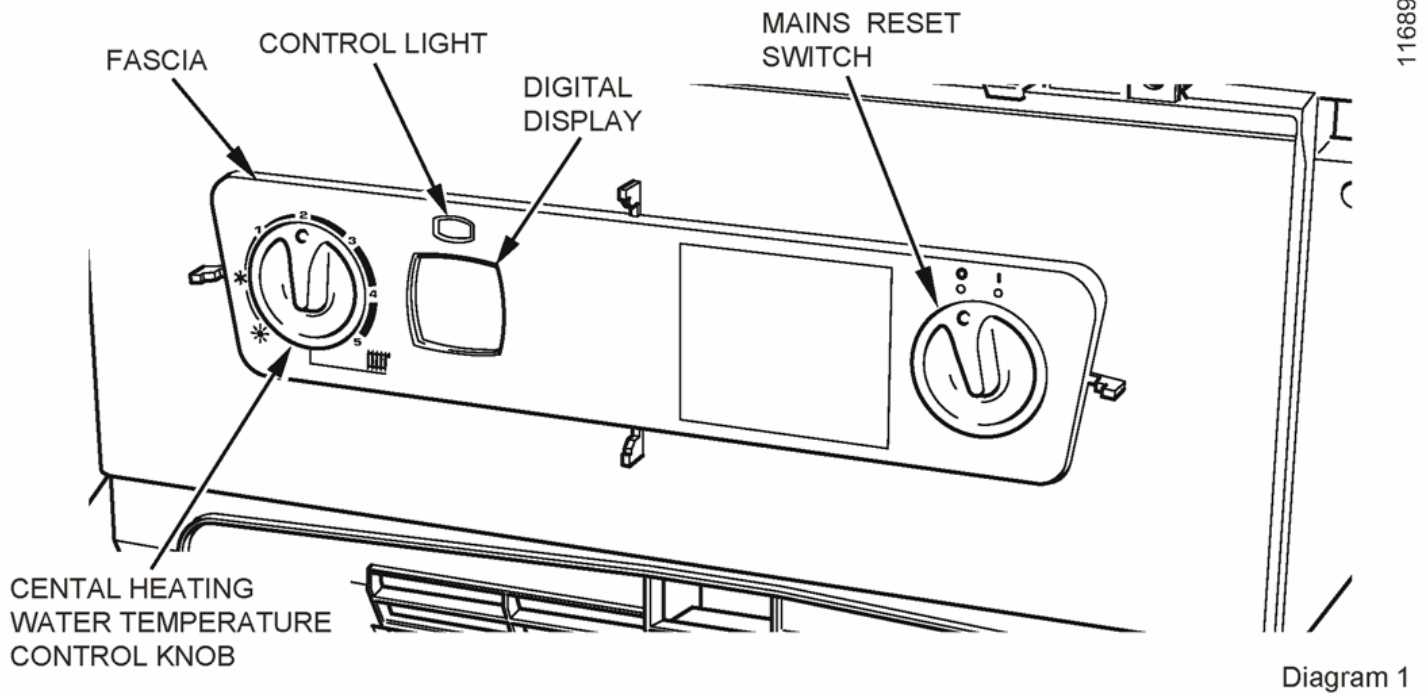

1 General Information

IMPORTANT:

The boiler is supplied in one pack, the flue is supplied separately.

This boiler is for use only on G20 natural gas.

Where no British Standards exists, materials and equipment should be fit for their purpose and of suitable quality and workmanship.

Refer to Manual Handling Operations, 1992 Regulations.

The installation of this boiler must be carried out by a competent person in accordance with the rules in force in the countries of destination.

Manufacturer's instructions must not be taken as overriding statutory requirements.

1.1 Sheet Metal Parts

WARNING:

When installing the appliance, care should be taken to avoid any possibility of personal injury when handling sheet metal parts.

1.2 Statutory Requirements

The appliance is suitable only for installation in GB and IE and should be installed in accordance with the rules in force.

Draw attention, if applicable, to the current issue of the Gas Safety (Installation and Use) Regulations, Section 35, which imposes a duty of care on all persons who let out any property containing a gas appliance in the UK.

In GB the installation of the boiler must be carried out by a competent person as described in the following regulations:

The manufacturer's instructions supplied.

The Gas Safety (Installation and Use) Regulations.

The appropriate Buildings Regulations either The Building Regulations, The Building Regulations (Scotland), The Building Regulations (Northern Ireland).

The Water Fittings Regulations or Water byelaws in Scotland.

The Health and Safety at Work Act, Control of Substances Hazardous to Health (COSHH).

The Current I.E.E. Wiring Regulations.

Where no specific instructions are given, reference should be made to the relevant British Standard Code of Practice.

In IE, the installation must be carried out by a competent person and installed in accordance with the current edition of I.S.813 "Domestic Gas Installations", the current Building Regulations and reference should be made to the current ETCI rules for Electrical Installation.

In GB the following Codes of Practice apply:

BS4814, BS6798, BS5440 Part 1 and 2, BS5546 Part 1, BS5449, BS6891, BS6700, BS7074 Part 1 and 2, BS7593, BS7671.

In IE: I.S.813, BS5546, BS 5449, BS 7074, BS 7593.

Manufacturer's instructions must not be taken as overriding statutory requirements.

BSI Certification

This boiler certified to the current issue of EN 483 for performance and safety.

It is important that no alteration is made to the boiler, without permission, in writing, from Halstead Boilers Ltd.

Any alteration that is not approved by Halstead Boilers Ltd., could invalidate the warranty and could also infringe the current issue of the Statutory Requirements.

1.3 Gas Supply

The gas installation shall be in accordance with the relevant standards.

In GB this is BS6891.

In IE this is the current edition of I.S.813 "Domestic Gas Installations".

The supply from the governed meter must be of adequate size to provide a steady inlet working pressure of 20mbar (8in wg) at the boiler.

On completion, test the gas installation for soundness using the pressure drop method and suitable leak detection fluid, purge in accordance with the above standard.

1.4 Technical Data

All dimensions are given in millimetres (except as noted).

See [diagram 1.1](#) and [Tables 1](#) and [2](#).

Diagram 1.1

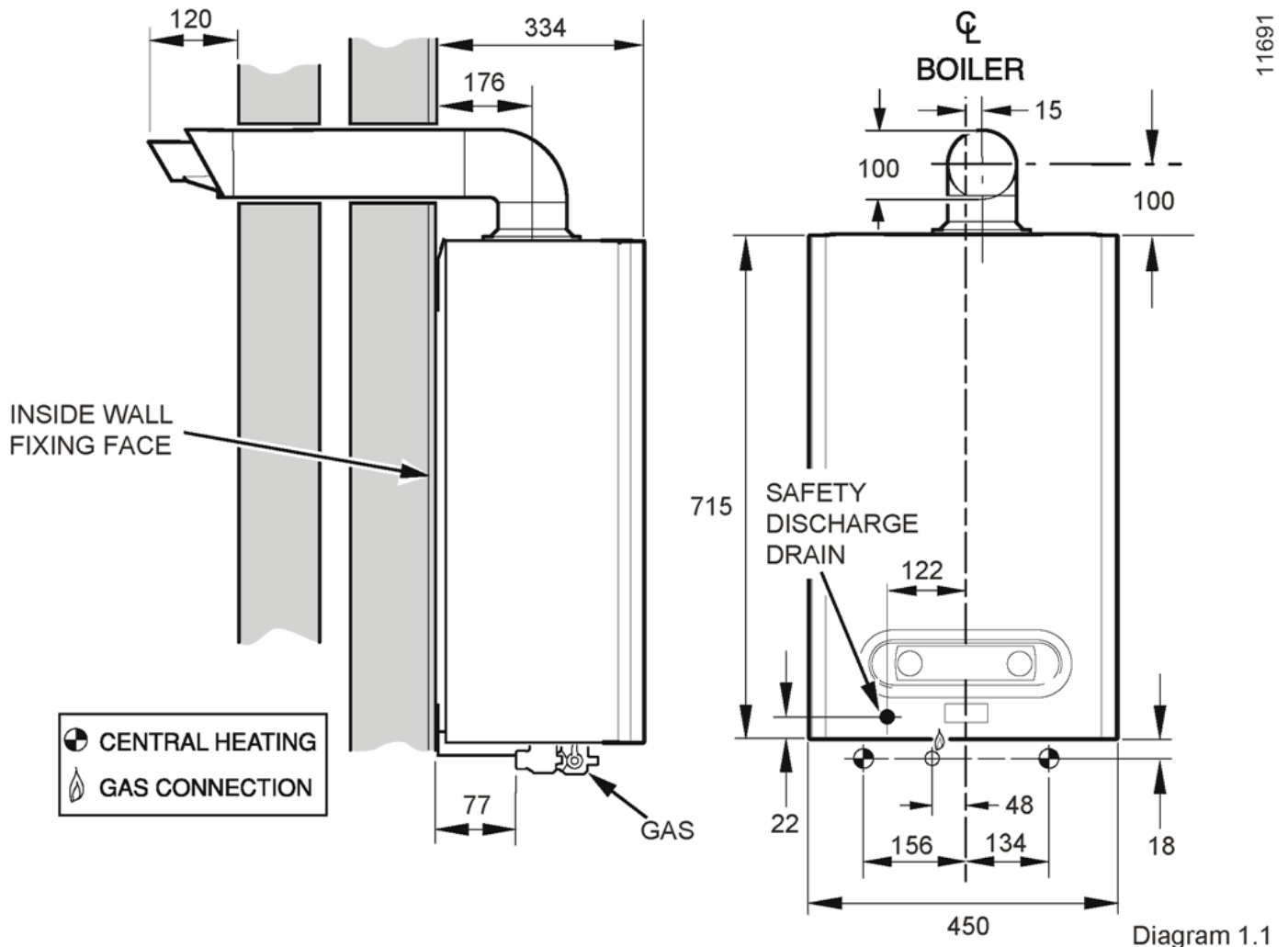

The data label is positioned on the inner door, refer to [diagram 1.2](#).

Diagram 1.2

HALSTEAD		Halstead Boilers Ltd. 20/22 First Avenue, Bluebridge Industrial Est. Halstead, Essex, CO9 2EX. Service - 01926 834834, Sales - 01787 475557	
EDEN Sb HIGH EFFICIENCY CONDENSING SYSTEM BOILER		2000 60728	
230V~50Hz 180W Fused at 3A For use on I _{2H} -G20 - 20 mbar This boiler is intended exclusively to be installed on a gas supply with a governed meter	GC No. 7-260-10		
	TYPE : C13, C33		
	EN 37 IP X D		
	NO _x Class 5		
WATER CIRCUIT PMS = 3 bar		CE 0086	
HEAT OUTPUT CONDENSING MODE = 30.1 kW		GB IE	
INJECTOR: N/A - DOES NOT APPLY		86/BN/726	
	MAXIMUM	MINIMUM	
HEAT INPUT NETT Q = kW	27.	5.0	
HEAT OUTPUT P = kW	27.0	.95	
SERIAL No.			

Diagram 1.2

The Seasonal Efficiency Domestic Boilers UK (SEDBUK) is: Eden Sb: Class 'A'.

The value is used in the UK Government's Standard Assessment Procedure (SAP) for energy rating of dwellings. The test data from which it has been calculated has been certified by B.S.I.

1.5 Electrical Supply

The boiler must be earthed.

All system components shall be of an approved type and all wiring to current I.E.E. wiring regulations.

External wiring must be correctly earthed, polarised and in accordance with the relevant standards.

In GB this is BS 6891.

In IE this is the current edition of I.S.813 "Domestic Gas Installations".

The boiler must be connected to a permanent 230V ac, 50Hz supply.

Connection of the whole electrical system of the boiler, including any heating controls, to the electrical supply must be through one isolator.

Isolation should be by a double pole switched fused spur box, with a minimum gap of 3mm for both poles. The fused spur box should be readily accessible and preferably adjacent to the appliance. It should be identified as to its use.

Alternatively connection can be made through an unswitched shuttered socket and 3A fused 3 pin plug both to the current issue of BS1363 may be used, provided they are not used in a room containing a bath or shower.

The mains supply cable and other cables connected to the boiler must be the PVC flexible type of at least 0.75mm² (24/0.20mm).

The colours of three core flexible cable are, blue - neutral, brown - live, green and yellow - earth.

The wire coloured blue must be connected to the terminal marked 'N' or 'Black'.

The wire coloured brown must be connected to the terminal marked 'L' or 'Red'.

The wire coloured green and yellow must be connected to the terminal marked 'E' or 'Green' or the earth symbol.

Diagram 1.3

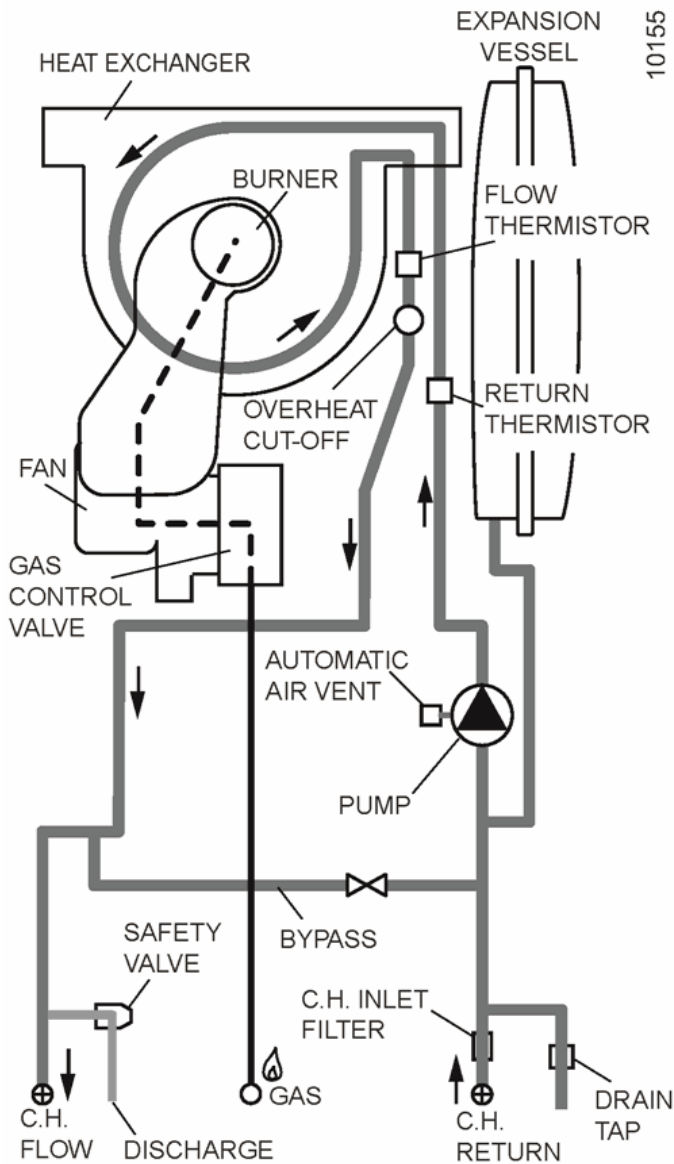

SCHEMATIC LAYOUT OF BOILER Diagram 1.3

1.6 Condensation Drain

A plastic drain pipe must be fitted to allow discharge of condensate to a drain.

Condensate should, if possible, be discharged into the internal household draining system. If this is not practical, discharge can be made externally into the household drainage system or a purpose designed soak away, see [section 9.2](#) for more details.

1.7 Heating System Controls

It is recommended that a programmer and room thermostat control the boiler.

Thermostatic radiator valves may be installed, however they must not be fitted in a room where the room thermostat is located.

NOTE:

For further information, see the current issue of the Building Regulations, approved document L1 (in the UK) and the references:

- 1) GIL 59, 2000: Central heating system specification (CheSS) and
- 2) GPG 302, 2001: Controls for domestic central heating system and hot water. BRECSU.

TABLE 1

Total Weight	33kg (73lb)
Gas connection	Rc½ (½in BSPT)
Water connection	22mm copper
Safety valve	Preset 3bar (43.5lbf/in ²)
Safety valve discharge	15mm copper
Expansion vessel capacity	8 litres (1.76 gallons)
Charge pressure	0.5bar (7.3lbf/in ²)

System min. pressure	0.7bar (10.1lbf/in ²)
Maximum system content using fitted expansion vessel	130 litres (28.6 gallons) at 75°C average system temperature
Electrical supply	230V~50Hz
Electrical rating	180W fused 3A
IP classification	X4D
Internal Fuse rating	
On Fan Supply	3.15 AT
On PCB	125mAT

Ball valves are fitted in water and gas connections.

For larger systems use an additional expansion vessel.

TABLE 2

RANGE RATING		MIN	MAX
BURNER %CO ₂		9.0 ± 0.2	9.0 ± 0.2
APPROXIMATE	m ³ /h	0.48	2.57
GAS RATE (after 10 mins from cold)	ft ³ /h	16.8	91

2 Boiler Location and Ventilation

2.1 Location

The boiler is not suitable for fitting outdoors.

This boiler may be installed in any room, although particular attention is drawn to the installation of a boiler in a room containing a bath or shower where reference must be made to the relevant requirements.

In GB this is the current I.E.E. WIRING REGULATIONS and BUILDING REGULATIONS.

In IE reference should be made to the current edition of I.S.813 "Domestic Gas Installations" and the current ETCI rules.

The boiler must be mounted on a flat wall, which is sufficiently robust to take its total weight, see [section 1 General Information, Data Table 1](#).

Any electrical switch or boiler control using mains electricity must be positioned so that a person using a bath or shower cannot touch it.

2.2 Clearances

The boiler should be positioned so that at least the minimum operational and servicing clearances are provided, see [diagram 2.1](#).

Diagram 2.1

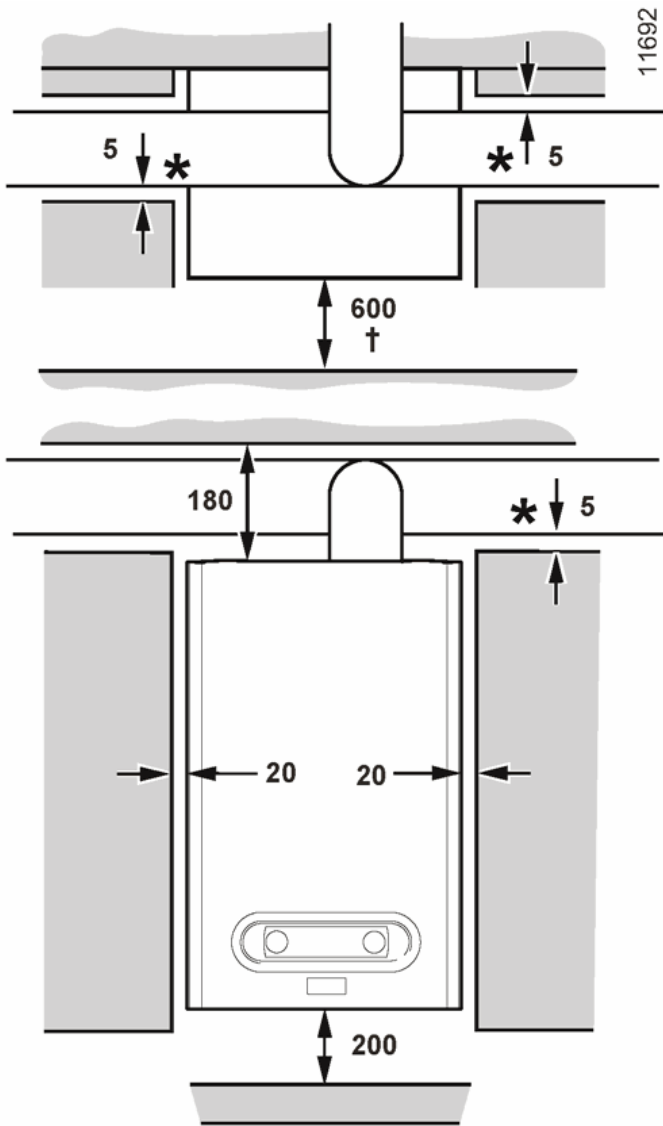

* Increase to 25mm clearance from combustible material.

† A removable compartment door can be placed at least 5mm in front of the appliance.

MINIMUM CLEARANCE FROM PERMANENT SURFACES

Diagram 2.1

Additional clearances may be beneficial around the boiler for installation and servicing.

For flue installations where external access is not practicable, consideration should be given for the space required to insert the flue internally, which may necessitate clearance larger than those specified in [diagram 2.1](#).

2.4 Timber Frame Buildings

If the boiler is to be installed in a timber building it should be fitted in accordance with the Institute of Gas Engineers document IGE/UP/7/1998. If in doubt seek advice from the local gas undertaking or Halstead Boilers Ltd.

2.5 Room Ventilation

The boiler is room sealed, so when it is installed in a room or space, a permanent air vent is not required.

2.6 Cupboard or Compartment Ventilation

Due to the high efficiency and hence low casing temperature of this boiler, cupboard or compartment ventilation is not necessary.

Leave existing air vents.

3 Flue Location and Ventilation

3.1 Flue Position and Length

The standard horizontal flue is fitted onto the top of the boiler.

See [diagram 3.1](#) and [3.2](#) to determine whether a standard flue can be used.

Diagram 3.1

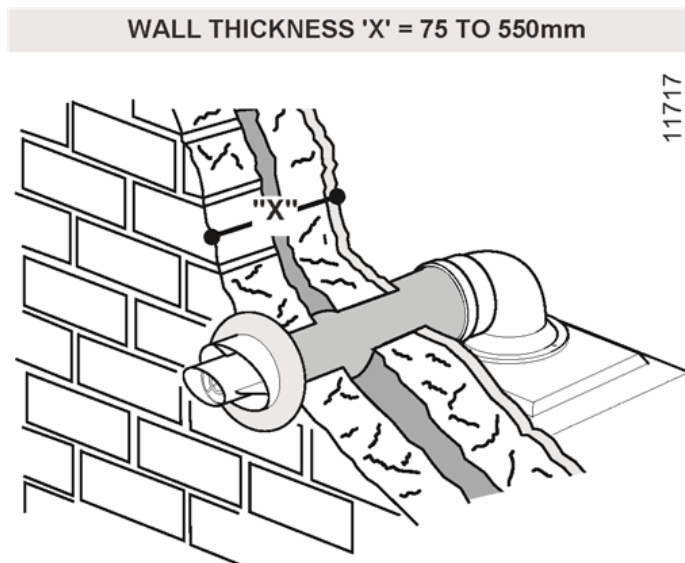

REAR FLUE - STANDARD

Diagram 3.1

Diagram 3.2

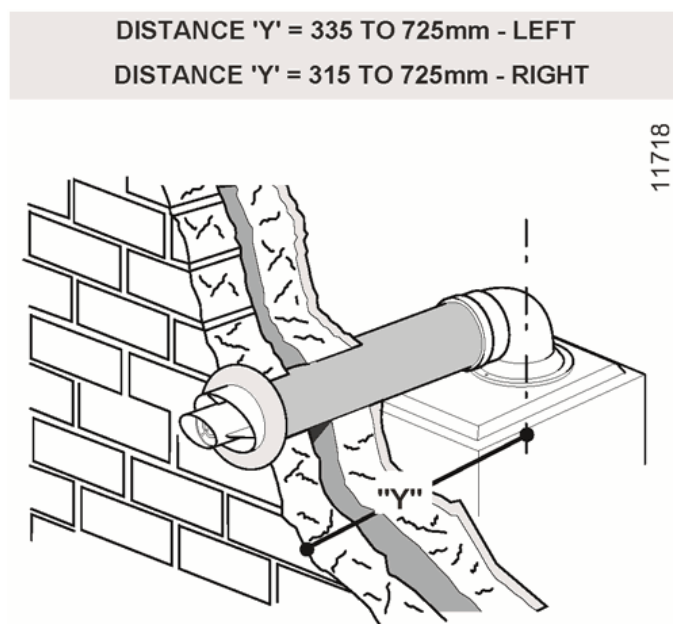

SIDE FLUE - STANDARD

Diagram 3.2

An elevated flue system can be installed with the addition of extension kits, see section below, Flue Options.

When extension pipes are used the flue system must be designed to have a continuous fall to the boiler of at least 2.5° to allow condensate to run out via the drain.

3.2 Internal Flue Installation

The flue can be installed from inside the building when access to the outside wall face is not practicable.

3.3 Flue Options

There are various flue systems to choose from, as follows:

Standard horizontal flue kit - Pt. No. 956065

Vertical flue terminal Kit - Pt. No. 956064

1 Metre Extension Kit - Pt. No. 956067

0.5 Metre Extension Kit - Pt. No. 956066

45° Flue Bend Pack - Pt. No. 956069

90° Flue Bend Pack - Pt. No. 956068

Additional accessories are available.

See Halstead "Flue Options Guide" for configurations available.

3.4 Terminal Position

The minimum acceptable siting dimensions for the terminal from obstructions, other terminals and ventilation openings are shown in [diagram 3.3](#).

Diagram 3.3

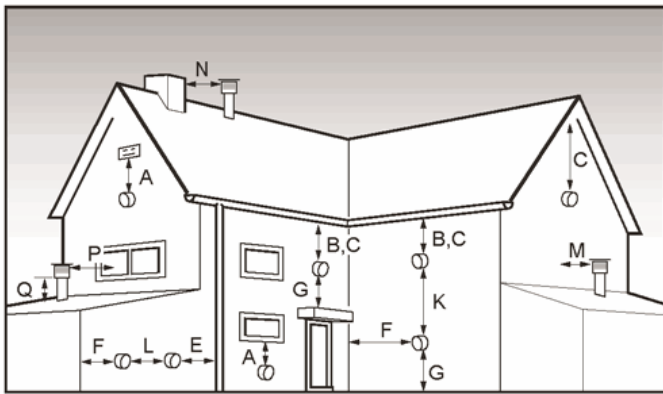

UNDER CAR PORT etc.

11508

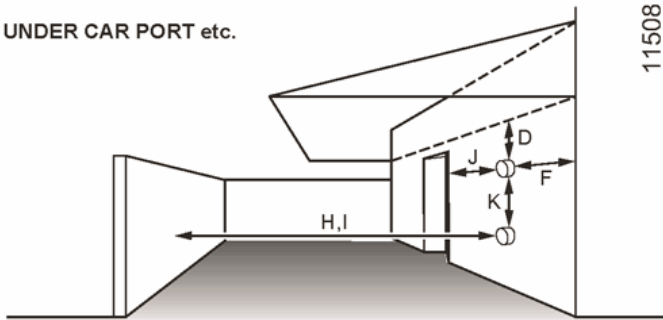

MINIMUM SITING DIMENSIONS FOR FANNED FLUE TERMINALS POSITION MM

HORIZONTAL FLUES

A	DIRECTLY BELOW, ABOVE OR HORIZONTALLY TO AN OPENING, AIR BRICK, OPENING WINDOW, AIR VENT, OR ANY OTHER VENTILATION OPENING	300
B	BELOW GUTTER, DRAIN/SOIL PIPE	75
C	BELOW EAVES	200
D	BELOW A BALCONY OR CAR PORT	200
E	FROM VERTICAL DRAIN PIPES AND SOIL PIPES	150
F	FROM INTERNAL/EXTERNAL CORNERS OR TO A BOUNDARY ALONGSIDE THE TERMINAL	300
G	ABOVE ADJACENT GROUND OR BALCONY LEVEL	300
H	FROM SURFACE OR A BOUNDARY FACING THE TERMINAL	600
I	FACING TERMINALS	1200
J	FROM OPENING (DOOR/WINDOW) IN CAR PORT INTO DWELLING	1200
K	VERTICAL FROM A TERMINAL	1500
L	HORIZONTALLY FROM A TERMINAL	300

VERTICAL FLUES

M	FROM ADJACENT WALL TO FLUE	300
N	FROM ANOTHER TERMINAL	600
P	FROM ADJACENT OPENING WINDOW	1000
Q	ABOVE ROOF LEVEL	300

Diagram 3.3

The terminal must be exposed to the external air, allowing free passage of air across it at all times.

Being a condensing boiler some plumbing may occur from the flue outlet. This should be taken into consideration when selecting the position for the terminal.

Carports or similar extensions of a roof only, or a roof and one wall, require special consideration with respect to any openings, doors, vents or windows under the roof. Care is required to protect the roof if made of plastic sheeting. If the carport comprises of a roof and two of more walls, seek advice from the local gas supply company before installing the boiler.

3.5 Terminal Guard

A terminal guard is required if persons could come into contact with the terminal or the terminal could be subject to damage.

In a terminal guard is required, it must be positioned to provide minimum of 50mm clearance from any part of the terminal and be central over the terminal.

The guard should be similar to that shown in [diagram 3.4](#).

Diagram 3.4

TERMINAL GUARD

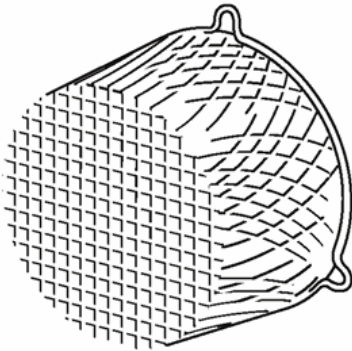

Diagram 3.4

A suitable guard is manufactured by:

Tower Flue Components

Morley Rd.

Tonbridge

Kent

TN9 1RA

Size: 280 × 280 × 270mm.

4 Heating System

4.1 General

The boiler is for use only with sealed central heating systems.

The safety valve is an integral part of the boiler and it cannot be adjusted.

The digital read-out on the controls fascia indicates the system pressure when there is no demand.

The circulation pump is integral with the boiler.

All domestic hot water circuits, connections, fittings must be in accordance with the relevant standards and water supply regulations.

For GB: Guidance G17 to G24 and recommendation R17 to R24 of the Water Regulations Guide.

For IE: The current edition of I.S.813 "Domestic Gas Installations".

4.2 Expansion Vessel

The boiler has an integral expansion vessel with a capacity of 8 litres (1.76 gallons), with a change pressure of 0.5bar.

NOTE:

The expansion vessel volume depends on the total water system volume and the initial system design pressure. To check if an additional expansion vessel is required, an accurate calculation of vessel size is given in the current issue of BS5449 and BS7074 Part 1.

Guidance on vessel sizing is also given in the current issue of BS5449 and BS7074 Part 1, for IE refer to the current edition of I.S.813 "Domestic Gas Installations".

4.3 Flow Rate

The flow rate through the boiler must not be allowed to fall below that given in [table 4](#).

The system can be fitted with a lockable balancing valve if necessary in the main flow or return pipes shown as valve "A" in [diagram 4.1](#).

Diagram 4.1

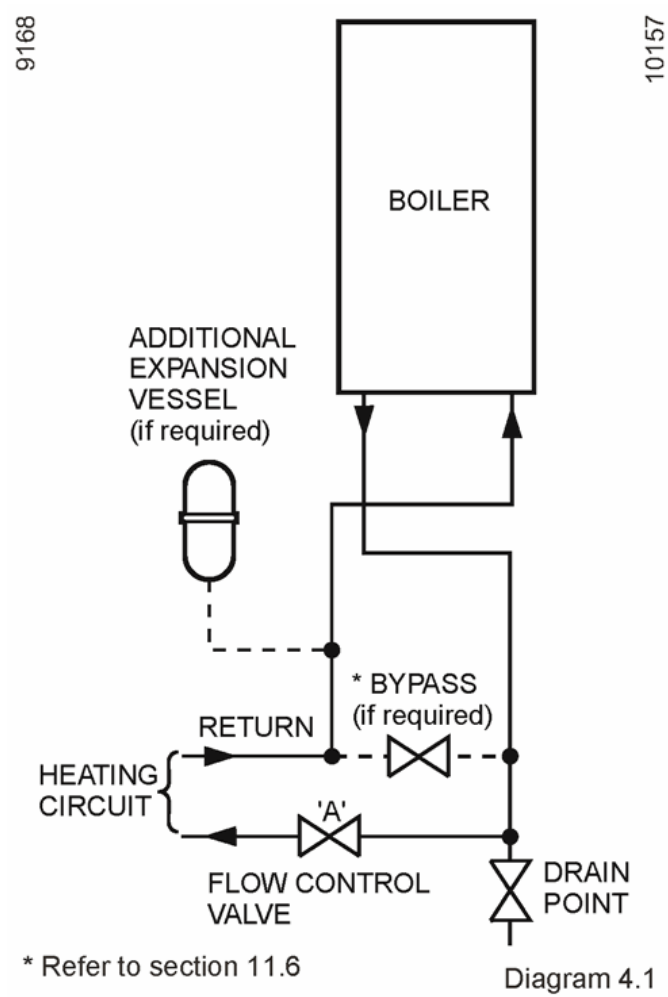

Table 4. Flow Rate

MINIMUM FLOW RATE
19.4 litres/min.
This is equal to 20°C differential at maximum heat input.

4.4 Bypass

The boiler is fitted with an adjustable automatic bypass. Ensure that under no circumstances does the flow rate drop below the figure specified, refer to [table 4](#) and [section 11.6](#).

4.5 Filling the Sealed System

Provision for filling the system at low level must be made, see [diagram 4.2](#). There must be no permanent connection to the mains water supply, even through a non-return valve.

Diagram 4.2

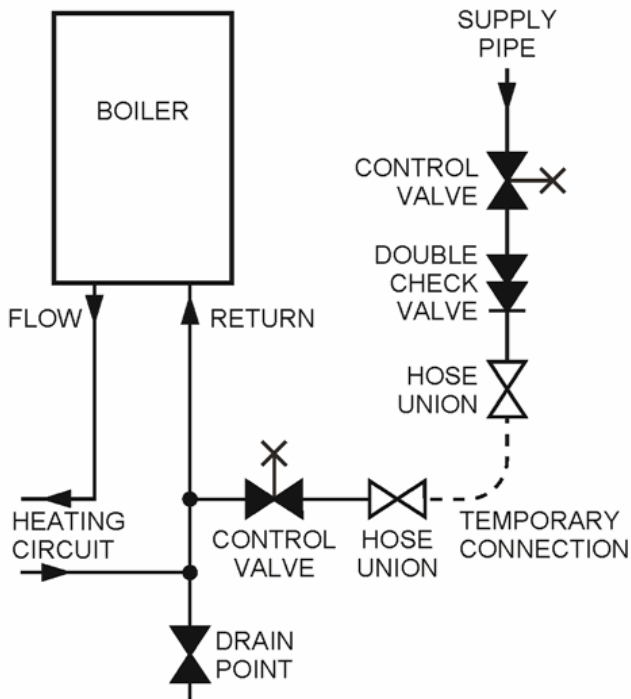

Method 1

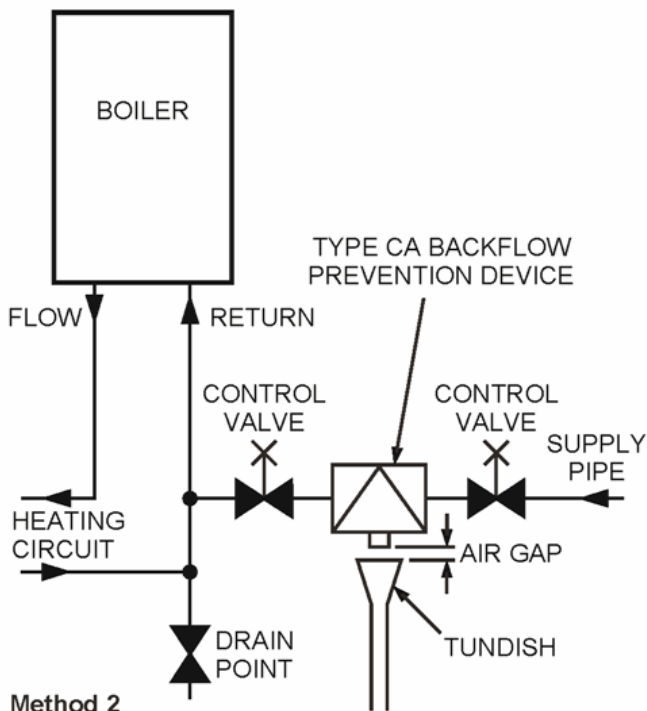

Method 2

Diagram 4.2

NOTE:

It is important that fittings used for connection to potable water comply with the water undertakings requirements.

4.6 Water Treatment

In the case of an existing installation, it is **ESSENTIAL** that prior to installing the new boiler the system is thoroughly flushed. For optimum performance after installation of a new system, the boiler and its associated central heating system should also be flushed. Flushing should be carried out in accordance with BS7593: 1992 using a cleanser such as Sentinel X300 or X400, Fernox Superfloc or Salamander.

For long-term corrosion protection, after flushing, an inhibitor suitable for stainless steel exchangers should be used, refer to the current issue of BS 5449 and BS 7593 on the use of inhibitors in central heating systems. Examples are Sentinel X100, Fernox or Salamander.

4.7 Draining Tap

A draining tap must be provided at the lowest points of the system, which will allow the entire system to be drained.

A drain tap for the appliance is provided as an integral part of the hydroblock, see [diagram 12.11](#).

5 Domestic Hot Water System

5.1 General

All domestic hot water circuits, connections, fittings must be in accordance with the relevant standards and water supply regulations.

For GB: Guidance G17 to G24 and recommendation R17 to R24 of the Water Regulations Guide.

For IE: The current edition of I.S.813 "Domestic Gas Installations".

5.2 Domestic Hot Water Cylinder

SINGLE FEED INDIRECT CYLINDERS ARE NOT SUITABLE AND SHOULD NOT BE USED.

The domestic hot water cylinder must be of the double feed indirect coil type. It must be suitable for working at a gauge pressure of 0.35bar above the safety valve setting.

6 Installation Preparation

6.1 Unpacking of Boiler

IMPORTANT:

With regards to the Manual Handling Operations, 1992 Regulations, the following lift operation exceeds the recommended weight for a one man lift.

Stand the boiler carton upright.

Cut and remove the securing straps and lift off the carton sleeve. Place aside any loose components until required.

Carefully lay the boiler on its back, remove the two front casing panel securing screws and lift off the panel from two retaining lugs, see [diagram 6.3](#).

Remove the two inner casing panel securing screws at the bottom front of the panel, then lift off the two retaining lugs, see [diagram 6.3](#).

6.2 Wall Template

Remove the wall template from the wall mounting pack and place in the desired position on a flat wall, giving due consideration to boiler clearances, see [section 2.2](#).

6.3 Flue Hole Cutting

The **standard horizontal flue** is designed with an internal fall of 35mm/metre towards the boiler for disposal of condensate. If the standard flue length alone is being used then the flue hole of diameter 105mm can be cut in the position marked on the wall template.

For **standard side flues** the horizontal flue centre line on the wall template should be extended to the side wall, and the vertical centre of the flue hole marked at 176mm from the back wall.

For installations with external access, a 105mm diameter core drill can be used.

For installations with internal access only, a 125mm diameter core should be used.

When using extension pipes with the horizontal rear flue, a core drill size of 125mm should be used to allow the extension pieces to slope at 35mm/metre (2.5°) towards the boiler.

For **extended side flues**, the flue hole centre should be determined by extending the dashed inclined line on the template to the side wall. This dashed line is drawn at 35mm/metre (2.5°) rise from the boiler. Where this line reaches the side wall, a horizontal line should be marked. The vertical centre line of the flue should then be marked at 176mm from the back wall, see [deagram 6.1](#).

Diagram 6.1

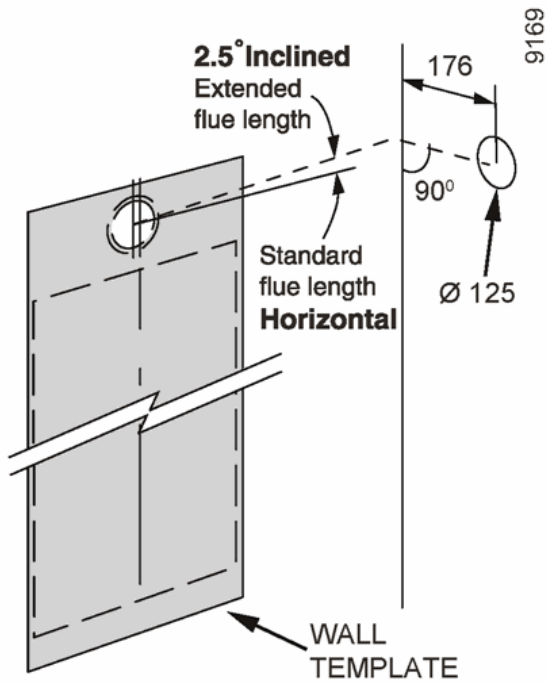

EXTENDED SIDE FLUE

Diagram 6.1

To allow for the flue passing through the wall at this angle a 125mm hole should be drilled irrespective of internal or external installation.

If necessary remove the wall template whilst drilling the flue hole.

6.4 Hanging Bracket Fixing

If previously removed, reposition the wall template over the flue hole and mark the position of the fixing holes for the hanging bracket, see [diagram 6.2](#).

Diagram 6.2

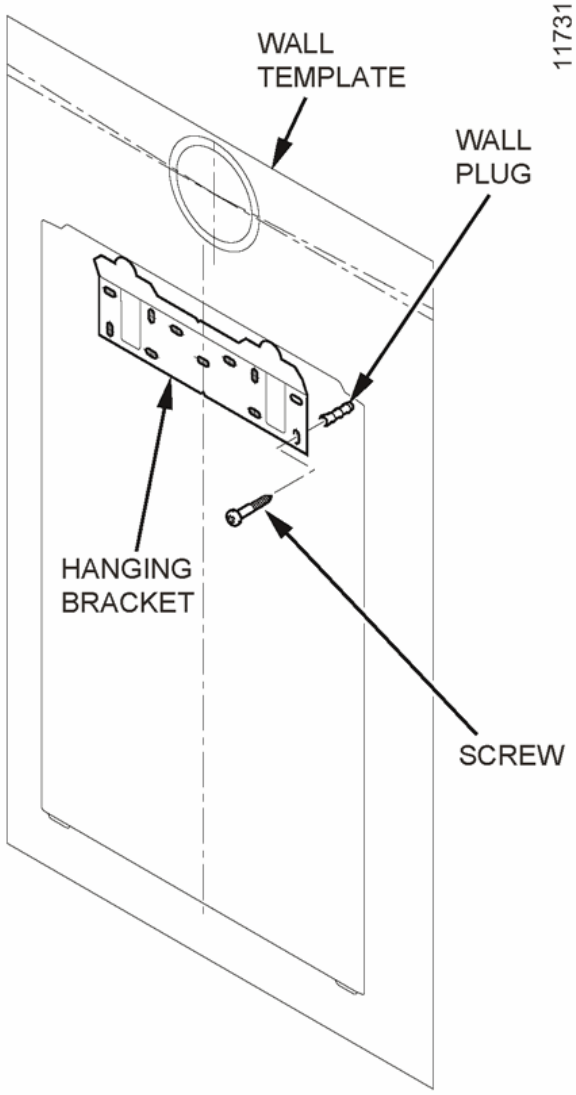

Diagram 6.2

Diagram 6.3

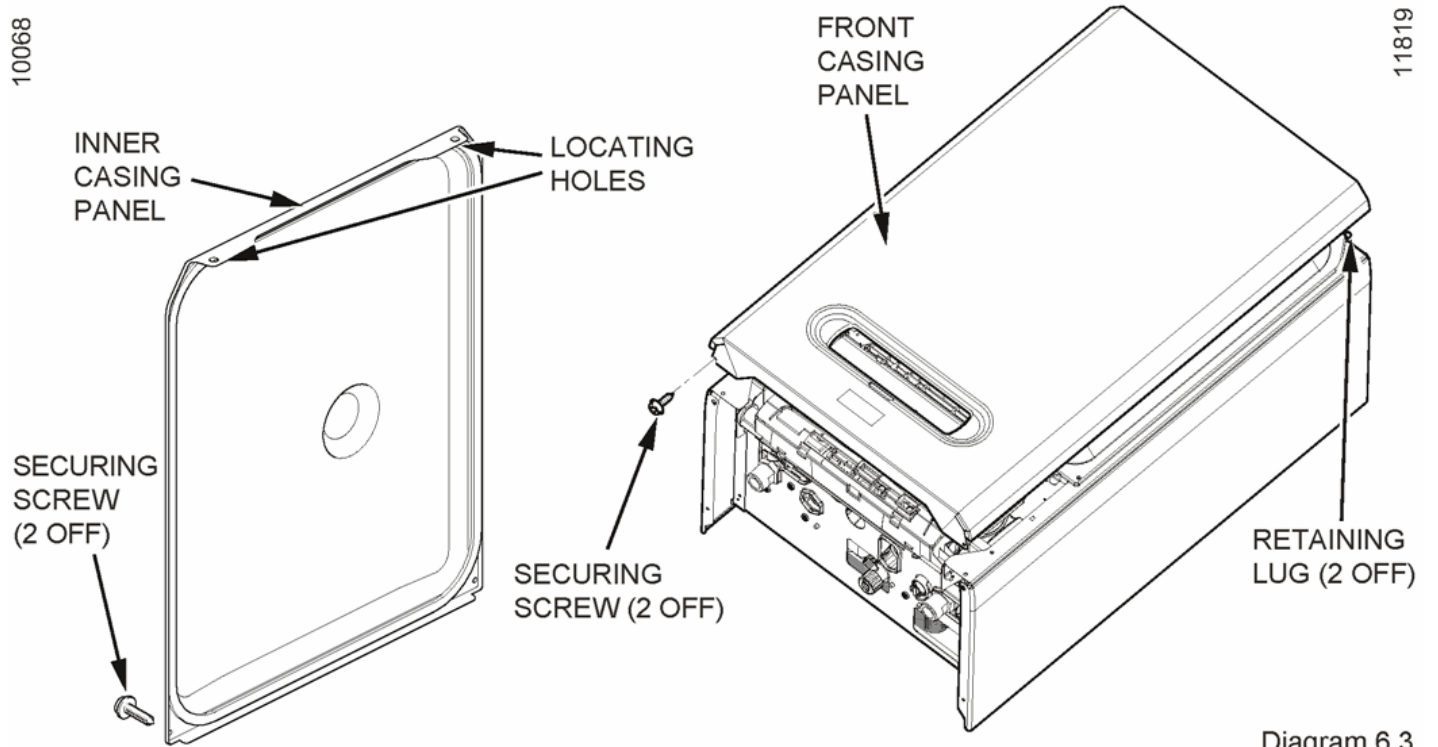

Diagram 6.3

Drill the fixing holes and insert suitable wall plugs.

If gas and/or water pipes are to be plumbed through the rear wall, the holes must be drilled as marked on the wall template prior to fixing.

Fix the hanging bracket to the wall using suitable screws.

7 Flue Preparation

7.1 Flue Length

All dimensions are in mm.

To determine flue length temporarily fit flue elbow to top of boiler.

For rear or side flue, measure the distance from the outside wall to the butt joint of the flue elbow fitted on top of the boiler. A standard flue system will be suitable if the length measured 'Y' is less than 633mm, see [diagram 7.1](#) and [7.2](#).

Diagram 7.1

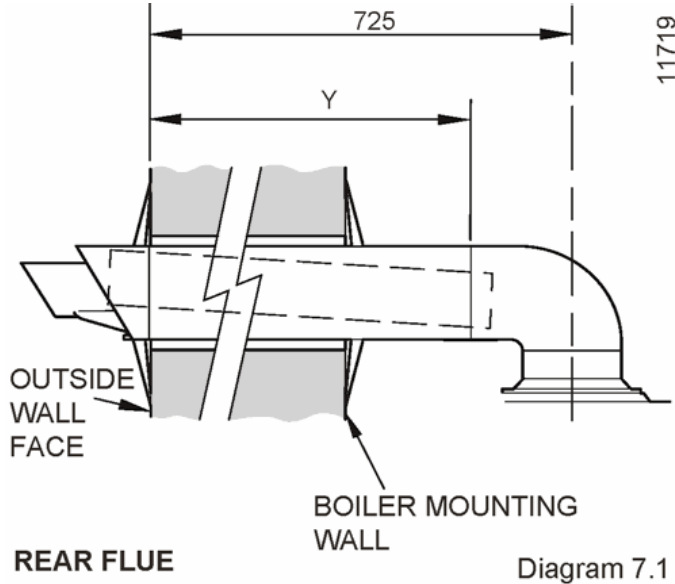
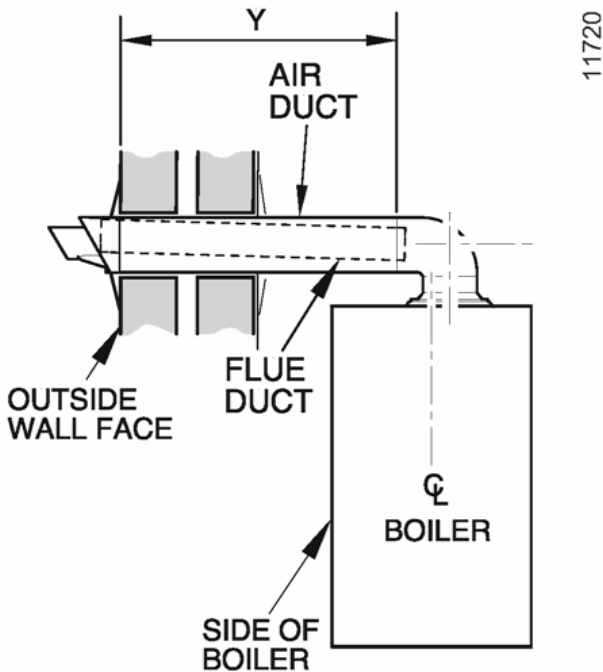

Diagram 7.2



If the measurement 'Y' exceeds 625mm then one or more extension pipes are required.

When cutting the flue duct should be cut flush with the air duct.

7.2 Extension pipes

Refer to [diagram 7.3](#) and [7.4](#).

Diagram 7.3

11721

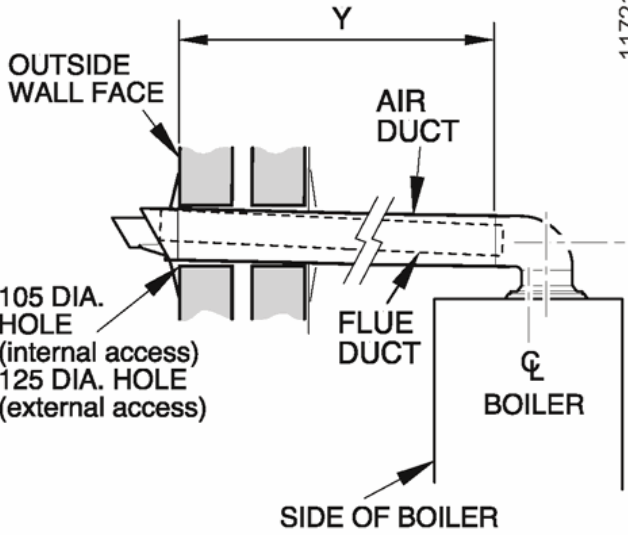

SIDE FLUE EXTENSION Diagram 7.3

Diagram 7.4

11722

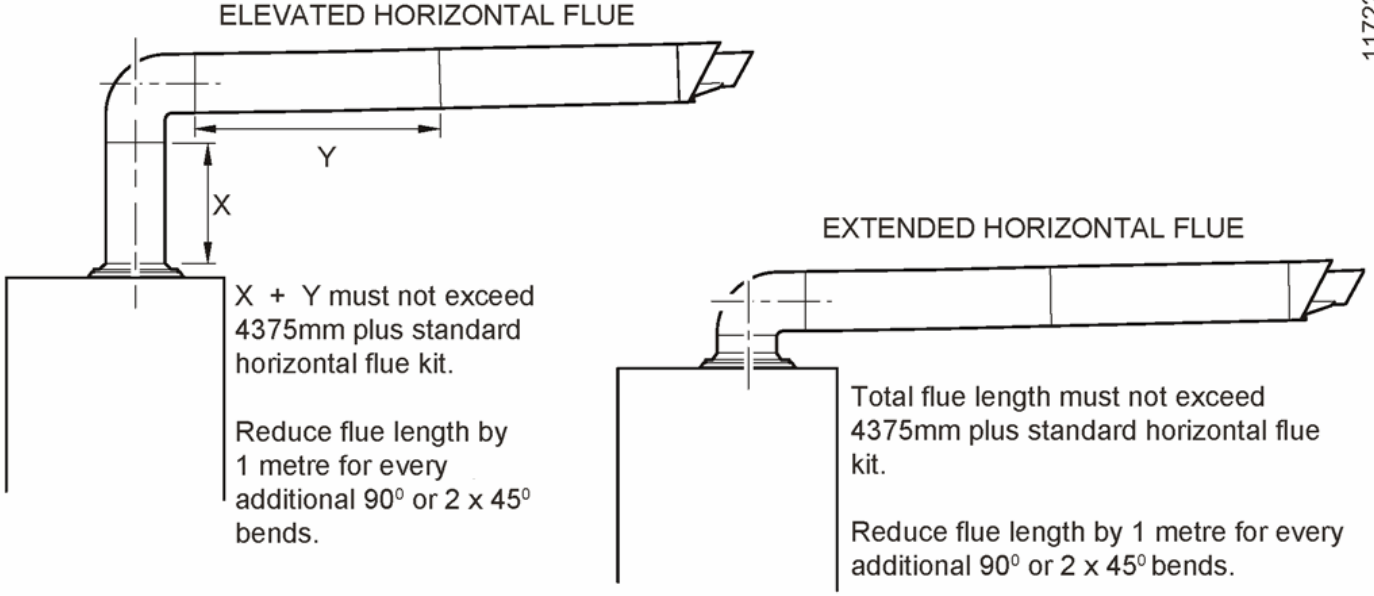

Diagram 7.4

Note maximum permitted lengths

When extension pipes are required it should be noted that the length of the air ducts which butt together are 960mm long and this should be taken into account when calculating the length that requires cutting.

For example:

- Distance from outside wall to butt joint on the flue elbow 'Y' = 2700 mm.
- Standard flue length = 625 mm.
- Extension pipe length = 960 mm.
- Length required of final extension pipe = $2700 - (625 + 960 + 960) = 155\text{mm}$.

In this example the final extension pipe would be cut to 155mm, this would be measured from the end of the air duct where the flue duct contains the 'o-ring' seal.

When cutting, the flue duct should be cut flush with the air duct at the opposite end to where the flue duct contains the 'o-ring' seal.

The system is made up from a standard horizontal flue kit and accessories. The accessories include flue extensions, bends 45° and 90° and fixing brackets.

The maximum permitted straight flue length is 4375 mm plus the standard horizontal flue. For each 90° or 45° x 2 bends fitted, the maximum length must be reduced by 1 metre.

NOTE:

45° x 2 bends can replace 1 x 90° if necessary. When using 90° bends any horizontal extension pipe should be inclined by a minimum of 2.5° fall towards the boiler to facilitate condensate removal.

7.3 Flue Assembly

The flue assembly is a push fit design.

Remove all burrs from cut pipes.

[Diagram 7.5](#) shows the components supplied in the standard kit and the flue adaptor.

Diagram 7.5

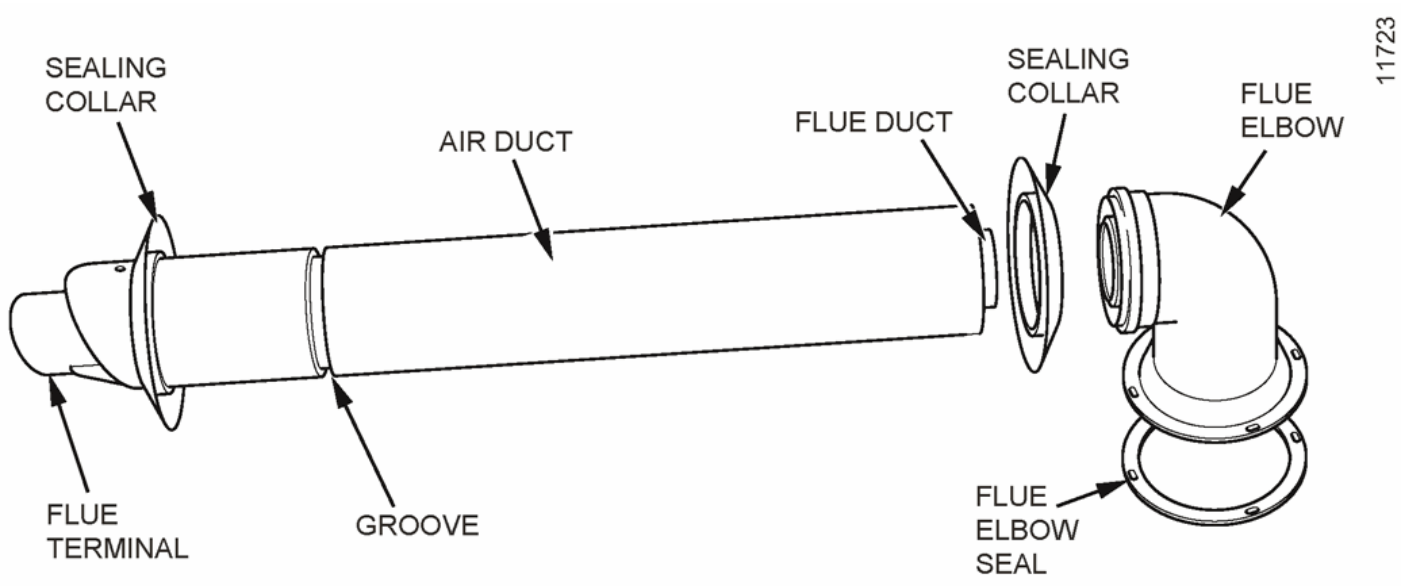

Diagram 7.5

Having cut the air and flue ducts as described in [sections 7.1-7.2](#) assemble the flue as follows, the flue can be fitted externally or entirely from inside.

Fit the rubber sealing collar behind the locating lugs on the flue terminal, see [diagram 7.5](#).

Push the flue assembly into the wall, externally or internally, initially until the end of the assembly protrudes a short way from the inside face of the wall. This will enable the inner rubber sealing collar to be positioned and allow the flue duct to be drawn back into the flue elbow after the boiler has been mounted.

7.4 Flue Attachment To Boiler

Refer to [section 8](#) and fix the boiler in position prior to completing the flue installation.

Refer to [diagram 7.5](#). Secure the flanged flue elbow in position on top of the boiler with four torque headed screws supplied, making sure the nib fits into the locating slot in the boiler casing to ensure correct orientation.

Draw flue assembly from wall, slide flue duct into flue elbow. Moisten the seals with water for easy push fit.

NOTE:

If the air and flue ducts have been correctly cut to the instructions given in [sections 7.1-7.2](#) the rubber sealing collar should fit flush with the outside wall, check this.

8 Gas/Water Connections and Boiler Fixing

8.1 Gas Connection

The gas supply can be connected from below or through the wall at the rear of the boiler, the position is shown on the wall template.

Refer also to [section 1.2](#).

Fit the sealing washer into the securing nut and make good the final connection to the gas service cock, see [diagram 8.1](#).

Diagram 8.1

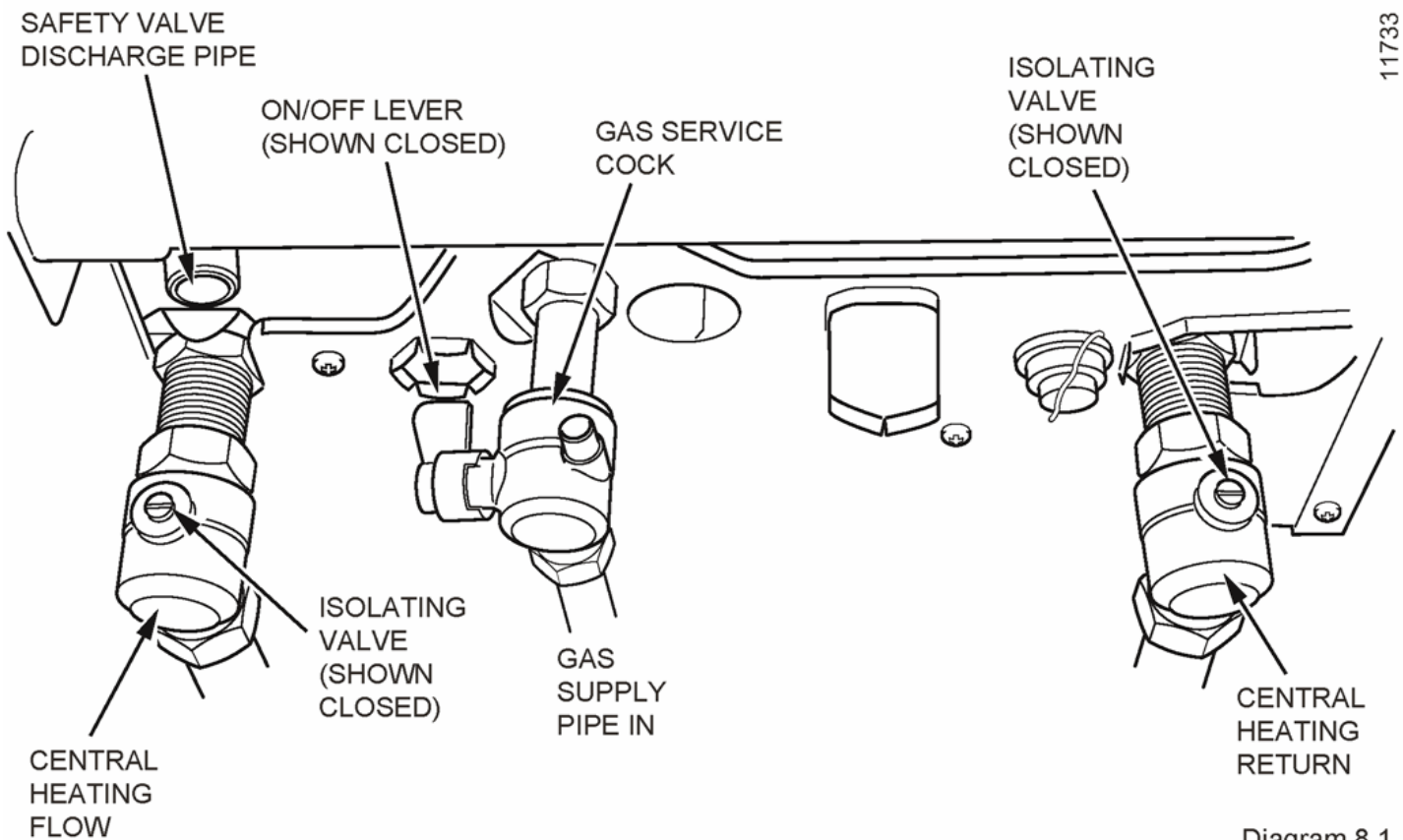

The whole of the gas installation, including the meter, should be inspected, tested for soundness and purged in accordance with the current issue of BS6891 and in IE the current edition of I.S.813 "Domestic Gas Installations".

Do not subject the gas service cock to heat.

Make sure the on/off lever is accessible.

8.2 Water Connections

Provision is made for the water connections to be made from below or through an internal wall at the rear of the boiler, the positions are shown on the wall template. Copper tailpieces, service cocks and gaskets are supplied in packs at the bottom of the boiler packaging.

Flush out the heating system before connecting to the boiler, refer to [section 4.6](#).

Make the connections to the heating system by fitting the sealing washers into the securing nuts and make good the final connection to the isolating valves, see [diagram 8.1](#).

Do not subject the isolation valves to heat.

IMPORTANT:

With regards to the Manual Handling Operations, 1992 Regulations, the following lift operation exceeds the recommended weight for a one man lift.

8.3 Boiler Fixing

Having previously secured the hanging bracket to the wall, lift the boiler into position in the following manner.

Lean the top of the boiler slightly to the wall and position just above the hanging bracket. Allow the boiler to slowly move downwards until engaged in the hanging bracket.

Slowly swing the base of the boiler to the wall ensuring that the connections on the boiler line up with gas and water isolation valves, see [diagram 8.1](#). Fit sealing washers into the securing nuts and make good the final connections.

Please refer to condensate connection before proceeding, see [section 9.2](#).

Attach the flue as described in [section 7.4](#).

9 Safety Valve Discharge and Condensate Connections

9.1 Safety Valve Discharge

The pipe from the safety valve must not discharge above an entrance, window or any type of public access area.

A short discharge pipe is supplied loose in the wall mounting pack. This must be extended, using not less than 15mm o.d. pipe, to discharge, in a visible position, outside the building, facing downwards, preferably over a drain, see [diagram 8.1](#).

The pipe must have a continuous fall and be routed to a position so that any discharge of water, possibly boiling, or steam, cannot create any danger to persons, damage to property or external electrical components and wiring.

To ease future servicing it is advisable to use a compression type fitting to extend the discharge pipe.

9.2 Condensate Drain Connection

The condensate drain connection is behind the pump at the rear of the boiler, see [diagram 9.1](#). 21.5mm plastic overflow pipe should be used to fit into the drain connection on the condensate siphon and discharge condensate to a drain. The drain pipe should have a fall of at least 2.5° away from the boiler.

Diagram 9.1

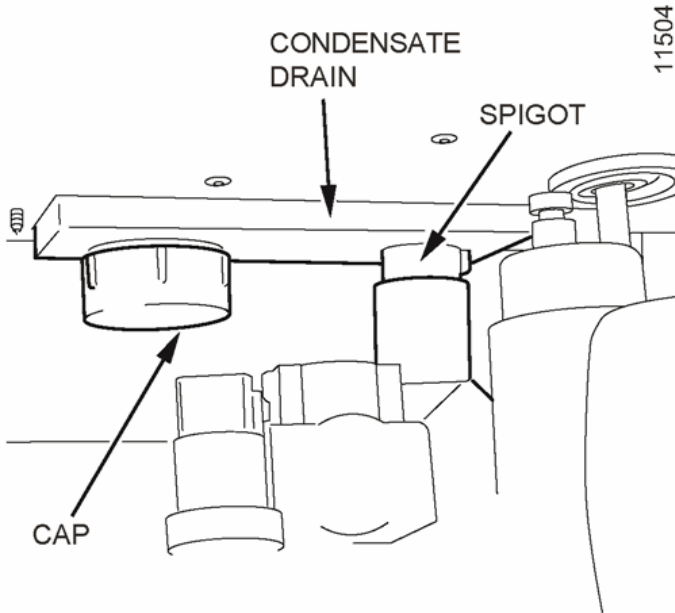

Diagram 9.1

Condensate should, if possible be discharged into the household internal drainage system. If this is not practicable, discharge can be allowed into the external household drains or a purpose designed soak-away.

It is recommended that any external condensate drain pipe is insulated and also preferably of 32mm diameter, to prevent freezing in adverse weather conditions.

The condensate is discharged periodically in 'slugs' by siphonic action.

It is not necessary to provide air breaks or extra traps in the discharge pipe as there is already a trap inside the boiler. Fitting an extra trap may cause the boiler siphon to work incorrectly. Refer to British Gas publication 'Guidance notes for the Installation to Domestic Condensing Boilers' for advice on the disposal of boiler condensate.

10 Electrical Connections

WARNING:

This appliance must be wired in accordance with these instructions. Any fault arising from incorrect wiring cannot be put right under the terms of the Halstead guarantee.

All system components must be of an approved type.

Electrical components have been tested to meet the equivalent requirements of the BEAB.

Connection of the whole electrical system and any heating system controls to the electrical supply must be through a common isolator.

Isolation should preferably be by a double pole switched fused spur box having a minimum contact separation of 3mm on each pole. The fused spur box should be readily accessible and preferably adjacent to the boiler. It should be identified as to its use.

A fused three pin plug and shuttered socket outlet may be used instead of a fused spur box provided that:

- a. They are not used in a room containing a fixed bath or shower.
- b. Both the plug and socket comply with the current issue of BS1363.

The mains electrical supply must be maintained at all times in order to provide domestic hot water.

Do not interrupt the mains supply with a time switch or programmer.

WARNING:

UNDER NO CIRCUMSTANCES MUST ANY MAINS VOLTAGE BE APPLIED TO ANY OF THE TERMINALS ON THE VOLTAGE FREE HEATING CONTROLS CONNECTION PLUG.

10.1 Mains Cable

IMPORTANT:

The mains cable comes supplied with the boiler, however, if a replacement supply cable is required it must be purchased. Part No. S1008600.

10.2 External controls (Mains Voltage)

Gain access to the 230V interface by unclipping the fascia panel and hinging forward, see [diagram 10.1](#).

Diagram 10.1

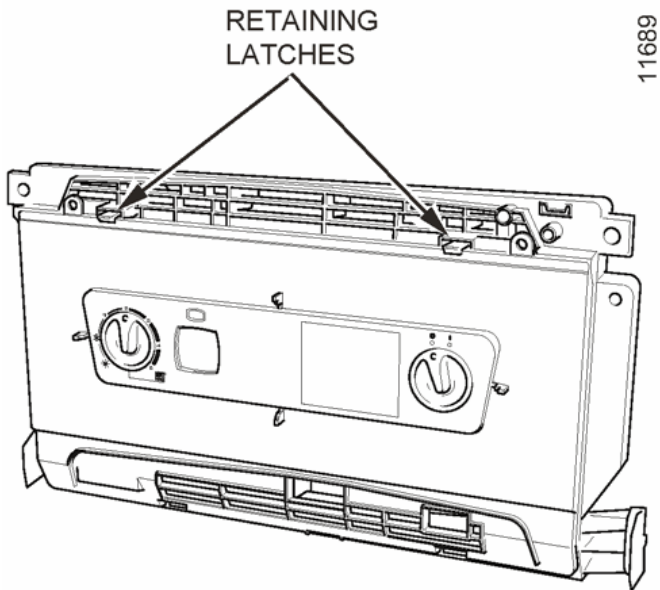

Diagram 10.1

Remove the red link from the mains voltage heating controls connection plug and connect as shown in [diagrams 10.2](#) & [10.3](#), then route the external control cable as shown on [diagram 10.2](#).

Diagram 10.2

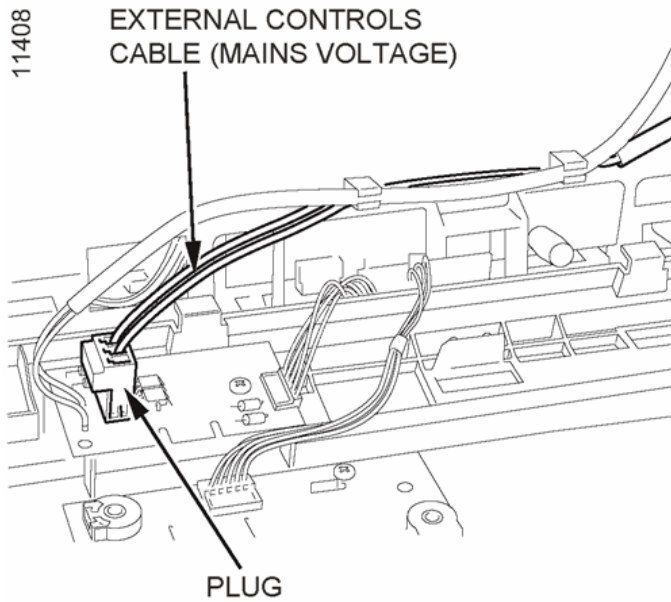
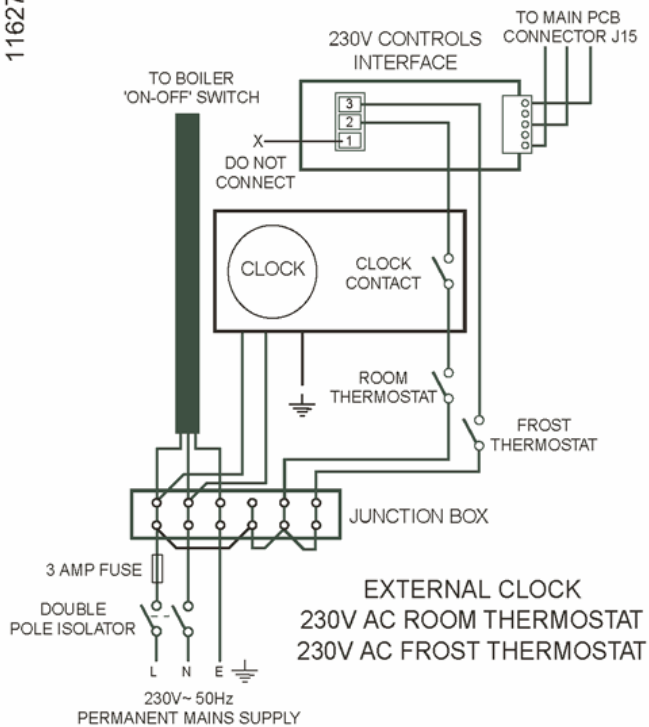

Diagram 10.2

Diagram 10.3

11627



11628

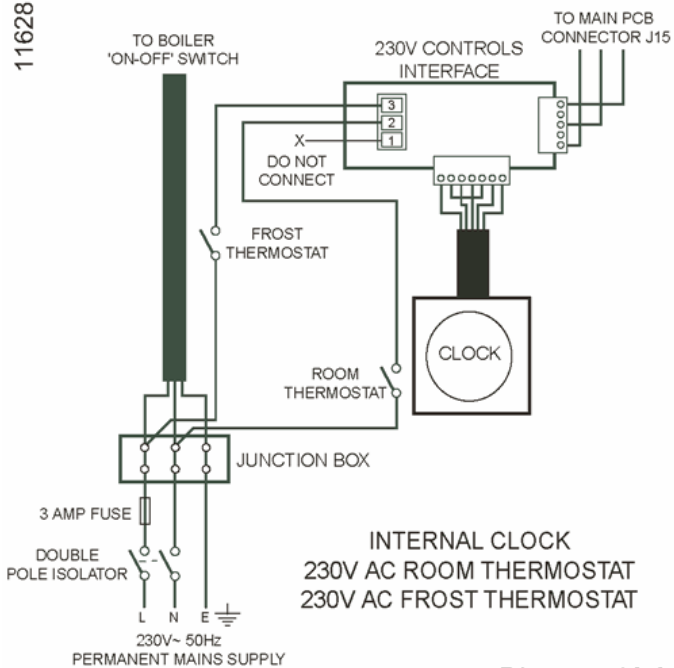

Diagram 10.3

Close the fascia panel and open the rear cover of control panel, see [diagram 10.4](#).

Diagram 10.4

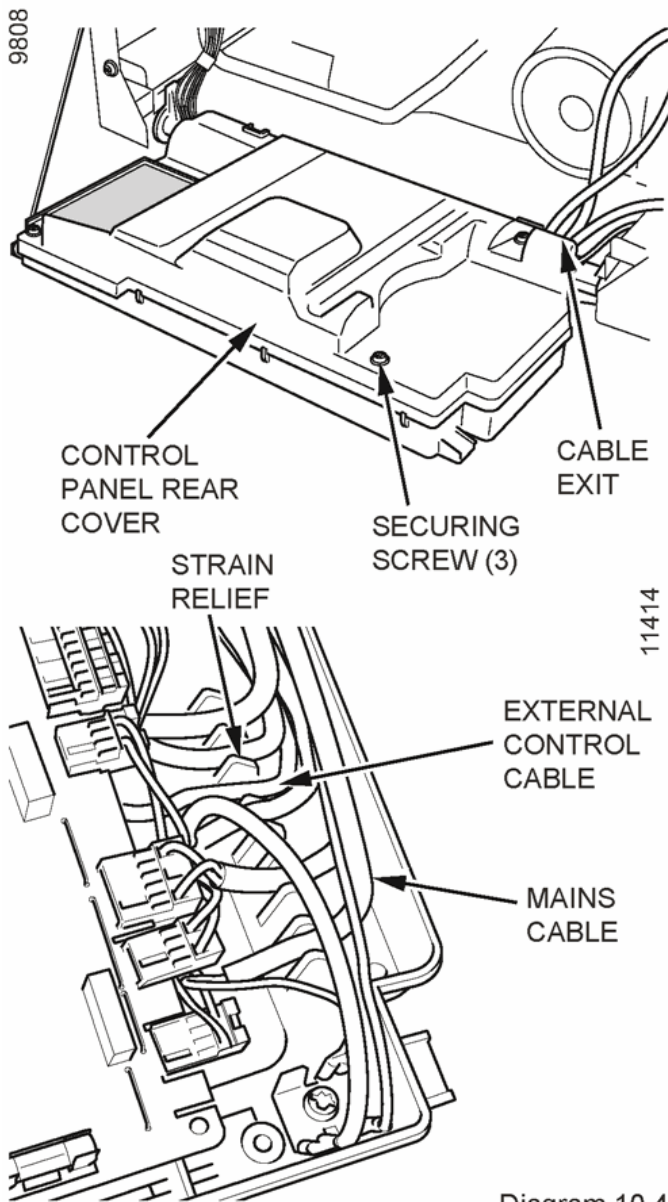

Diagram 10.4

Secure the external control cable in the strain relief, see [diagram 10.4](#).

Thread the external control cable through rear of the control panel where the other cables exit, see [diagram 10.4](#).

Close rear cover of control panel.

External control should be fitted in accordance with the rules in force.

Refer to wiring diagram in [Section 13](#).

10.4 Electrical Connections - Testing

Carry out preliminary electrical system checks as below:

1. Test insulation resistance to earth of mains cables.
2. Test the earth continuity and short circuit of cables.
3. Test the polarity of the mains.

Please ensure the "Benchmark" logbook is completed and left with the user and the magnetic lighting instructions label is placed on the surface of the boiler casing.

11 Commissioning

11.1 Preliminaries

A competent person in accordance with the current issue of BS6798 should carry out commissioning.

Make sure that the system has been thoroughly flushed out with cold water without the pump in place.

Refit the pump, fill the system with water, making sure that all the air is properly vented from the system and pump, see [diagram 11.1](#).

Diagram 11.1

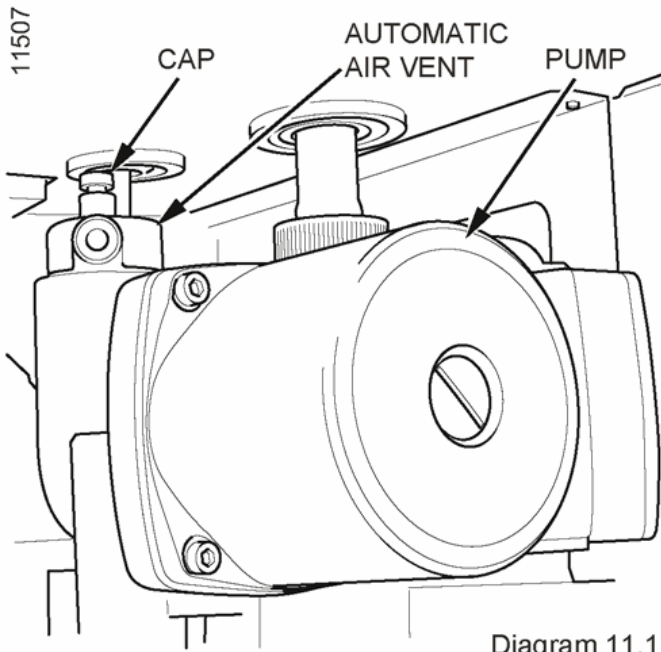

Before operating the boiler check that all external controls are calling for heat.

11.2 System Commissioning

Open the two central heating isolating valves, slots in line with the length of the valve, see [diagram 8.1](#)

To enable the system pressure to be viewed, turn the heating temperature knob to the OFF position.

Turn the mains electricity supply on to the appliance and ensure that the mains switch on the appliance fascia is set to the on position.

The system pressure should be viewed on the digital display on the front of the appliance, see [diagram 1](#)

Pressurise the system until the pressure on the display reads at least 1.0bar.

Make sure that the automatic air vent works correctly and that the black cap is loosely fitted to allow air to escape, see [diagram 11.1](#)

Check the heating system and boiler connections for water soundness.

11.3 Preparation for Lighting

Isolate the boiler from the mains electrical supply.

Test for gas soundness and purge air from the gas supply. Turn on the gas isolation valve, slot in line with the length of the valve, see [diagram 8.1](#).

11.4 Initial Lighting

The lighting procedure of the boiler is fully automated.

Check that all external controls are calling for heat. If an integral clock/timer is fitted check that it is correctly programmed and if necessary overridden to provide heat.

Ensure that the heating control knob is turned OFF

Turn on the mains electrical supply and the mains reset knob to (I) on the controls fascia.

The digital display will show system pressure.

Turn the central heating water temperature knob to (I) MINMUM.

The digital display will now show water temperature.

The fan should start and after a few seconds the ignition will commence

If the burner fails to light the fan will stop. Initially this may be due to air in the gas supply line. The boiler will automatically have three attempts at ignition.

If necessary turn the reset switch to the off position (O), then back to the on position (I) and the boiler will restart.

After the boiler has lit, allow to warm at minimum temperature setting to purge any air from the system.

Once the system has been purged of air, turn the central heating knob to the desired temperature.

The appliance will then continue to fire until the user controls are satisfied.

Note that after first power up the firing sequence changes. After one minute stabilisation time the boiler will ramp slowly to full rate rather than going immediately to full rate. This is an adaptive feature to cope with small system requirements.

11.5 Testing - Gas

Should any doubt exist about the gas rate, check it using the gas meter test dial and stop watch at least 10 minutes after the burner has lit, making sure that all other gas burning appliances and pilot lights are off.

The approximate gas rate: 2.57m³/h (91 ft³/h) is for guidance only.

The gas valve is factory set and should need no adjustment. It should be checked that the supply pressure is 20mb when the boiler is firing at full rate. This can be achieved by checking the inlet pressure at the tapping on the gas valve shown in [diagram 11.2](#).

Diagram 11.2

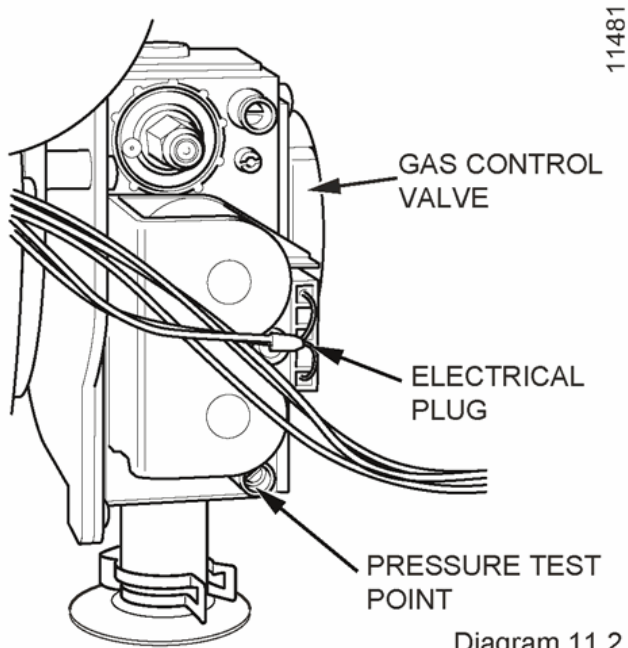

Disconnect pressure gauge.

Note that the burner pressure cannot be measured at the gas valve as it is altered by the suction of the fan and modulated according to demand.

Replace inner casing panel and front casing panel.

11.6 Testing - Heating System

Check that all remote controls are calling for heat. The boiler will fire automatically. Fully open all radiator valves and flow control valve 'A' if fitted, see [diagram 4.1](#).

Balance the radiators as required and if fitted adjust valve 'A' to give the required system differential. Turn off all radiators that can be shut off by the user and check to see if less than the maximum differential allowed of 20°C can be achieved across flow and return.

This boiler has a built in bypass, see [diagram 11.3](#) and [14.17](#).

The boiler is supplied with the bypass open half a turn. It should not be necessary to adjust the bypass, but if required turn the adjustment screw clockwise to close the valve, see [diagram 11.3](#).

Diagram 11.3

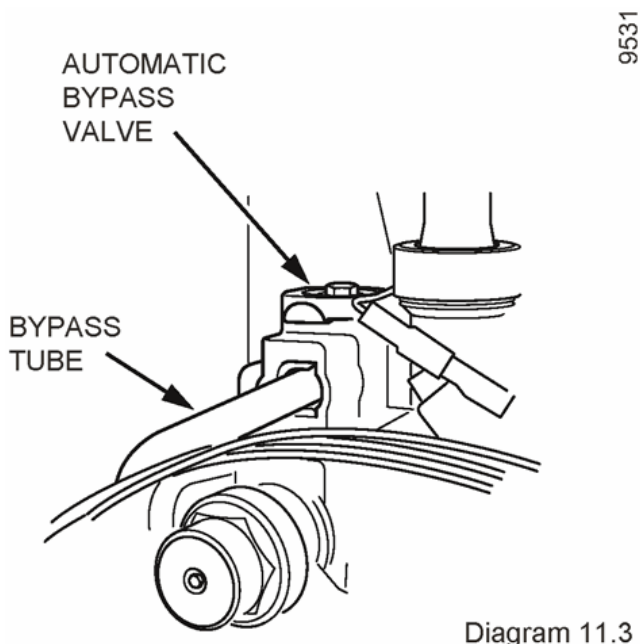

Allow the system to reach maximum temperature then switch off the boiler by isolating from the electrical supply.

Drain the entire system rapidly whilst hot, using the drain tap at the lowest part of the system. Fill and vent the system as described previously in [section 11.2](#).

Lock or remove the handle from control valve 'A' to prevent unauthorised adjustment.

11.7 User Controls and Options

The mains/reset switch is used to restart the boiler after a fault condition has occurred, i.e. ignition failure.

The heating control knob allows the user to set the desired temperature.

Temperature Display

The digital display normally shows the operating temperature of the unit.

11.8 Pump Exercise Program

After a power cut or every 24 hours in frost setting/summer mode the pump will run for one minute to prevent it from sticking. This will also occur during normal operating if there is no demand for more than 24 hours.

11.9 Frost Protection

The boiler has a built in frost protection programme as long as the electricity and gas are left switched on.

This device operates the burner and system pump when the temperature inside the boiler falls to 3°C.

When the temperature inside the appliance reaches 10°C the burner will shut down and after a short period the pump will stop.

This device primarily protects the boiler. Any other exposed areas of the system should be protected by a separate frost thermostat.

11.10 Instruct the User

Instruct and demonstrate the lighting procedure and advise the user on the safe and efficient operation of the boiler.

Instruct on and demonstrate the operation of any heating system controls.

Advise the user on the use and maintenance of any scale reducer and pass on any relevant instructional documents.

Advise that to ensure the continued efficient and safe operation of the boiler it is recommended that it is checked and serviced at regular intervals. The frequency of servicing will depend upon the installation conditions and usage, but in general, once a year should be enough.

Draw attention, if applicable, to the current issue of the Gas Safety (Installation and Use) Regulations, Section 35, which imposes a duty of care on all persons who let out any property containing a gas appliance in the UK.

It is the Law that any servicing is carried out by a competent person.

Advise the user that, like all condensing boilers this appliance will produce a plume of condensation from the flue terminal in cool weather. This is due to the high efficiency and hence low flue gas temperature of the boiler.

Advise the user of the precautions necessary to prevent damage to the system, boiler and the building, in the event of the heating system being out of use during frost or freezing conditions.

Advise the user that the permanent mains electrical supply SHOULD NOT be switched off, as the built in frost protection and pump saver program would not be operable.

Adjust the boiler temperature control and any system controls to their required settings. In addition it is necessary to complete the "Benchmark" logbook.

For IE, it is necessary to complete a "Declaration of Conformity" to indicate compliance to I.S.813. An example of this is given in the current edition of I.S.813.

Reminder, leave these instructions and the 'Benchmark' logbook with the user.

12 Servicing

REMEMBER, When replacing a part on this appliance, use only spare parts that you can be assured conform to the safety and performance specification that we require. Do not use reconditioned or copy parts that have not been clearly authorised by Halstead Boilers Ltd.

NOTE:

To ensure the continued efficient and safe operation of the boiler it is recommended that it is checked and serviced at regular intervals. The frequency of servicing will depend upon the particular installation and usage, but in general once a year should be enough.

It is the Law that any servicing is carried out by a competent person.

12.1 General

Refer to Table 3 [Section 1 General Information](#). Measurement of the products of combustion can be achieved by connection of a probe to the combustion analyser test point, see [diagram 12.1](#).

Diagram 12.1

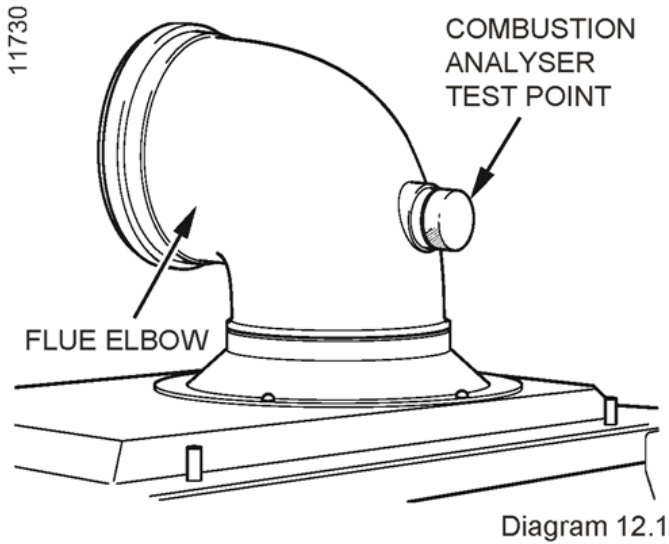

IMPORTANT:

Products of combustion will be discharged when the cap is removed. It is important to replace the cap immediately.

Before commencing with a service or replacement of parts the boiler should be isolated from the electrical supply and the gas supply should be turned off at the gas isolation valve, see [diagram 8.1](#).

All routine servicing requirements can be achieved by the removal of the front panel and inner panel only. To remove simply undo the two screws on the underside of the front panel and lift off, see [diagram 6.3](#). Undo the two screws on the front of inner panel and lift off, see [diagram 6.3](#).

Unless stated otherwise any part removed during servicing should be replaced in the reverse order to removal.

Servicing should always include the removal of any debris from the condensate pipe and siphon.

After completing any servicing of gas carrying components, ALWAYS test for gas soundness and carry out a functional test of the controls.

12.2 Spark Electrode

Disconnect the electrode lead and two securing screws. Withdraw the spark electrode carefully from the combustion chamber, see [diagram 12.2](#) and [12.5](#).

Diagram 12.2

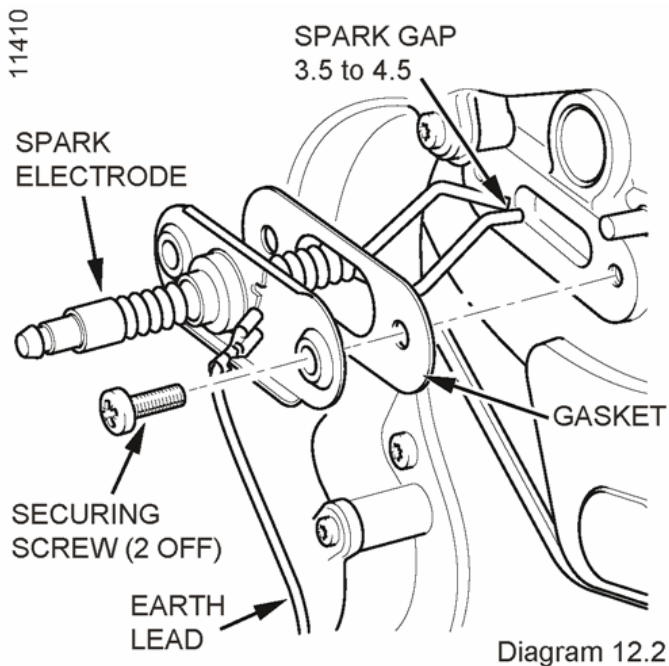

Diagram 12.3

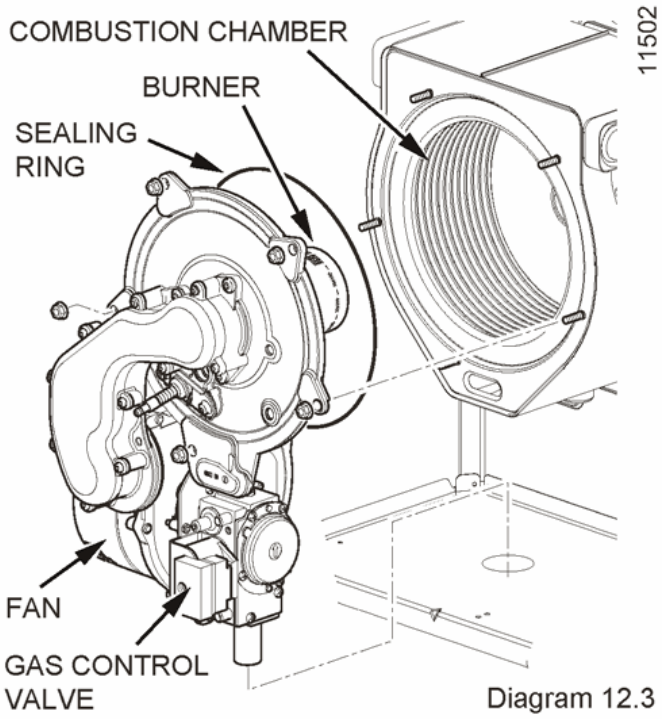

Diagram 12.4

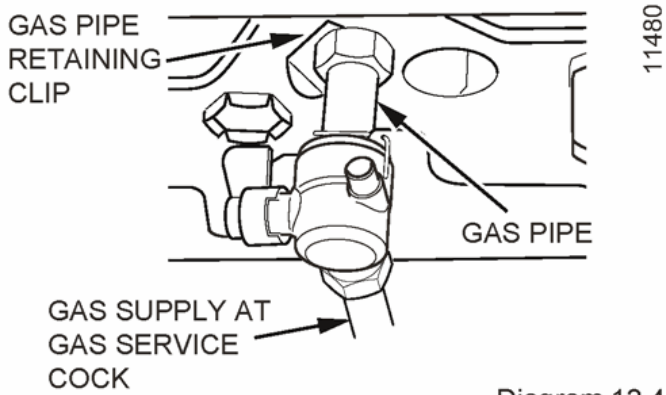
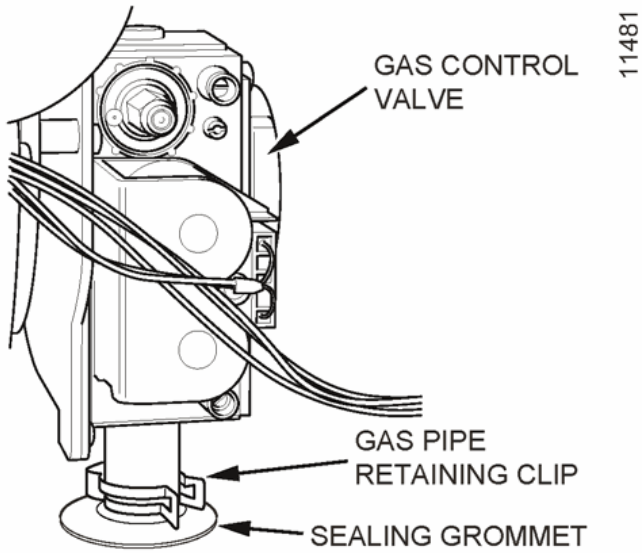
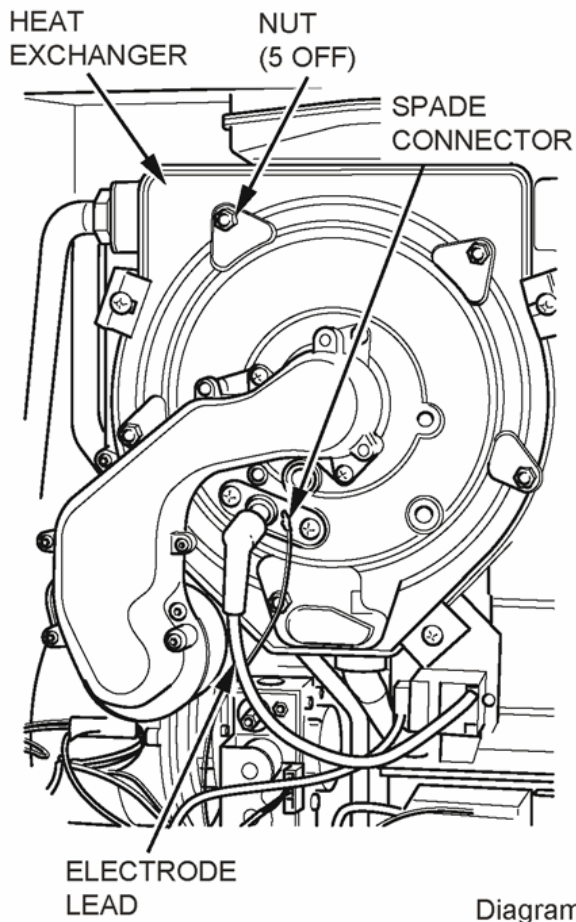

Diagram 12.5



11531

Diagram 12.5

Inspect the tips for damage.

Clean away any debris and check the spark gap is 3.5 to 4.5 mm.

Check the electrode gasket for signs of leakage and replace if necessary.

12.3 Burner

NOTE:

IF THE BURNER HAS TO BE REMOVED IT WILL REQUIRE A NEW GASKET WHEN REFITTED.

Drop down the control panel into the service position, see [diagram 12.8](#).

Diagram 12.6

OFFSET
ADJUSTMENT

11481

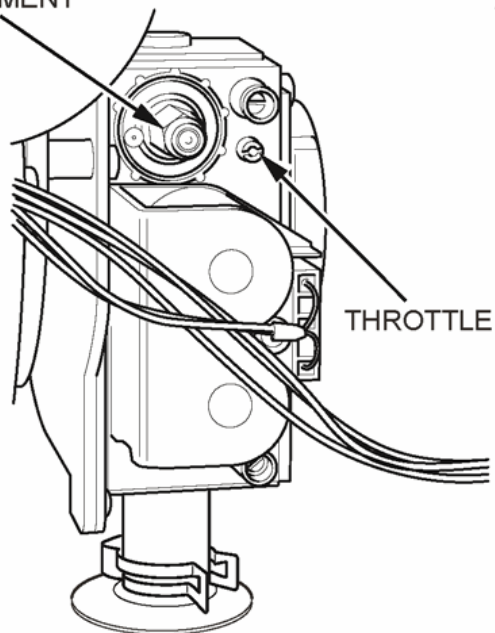
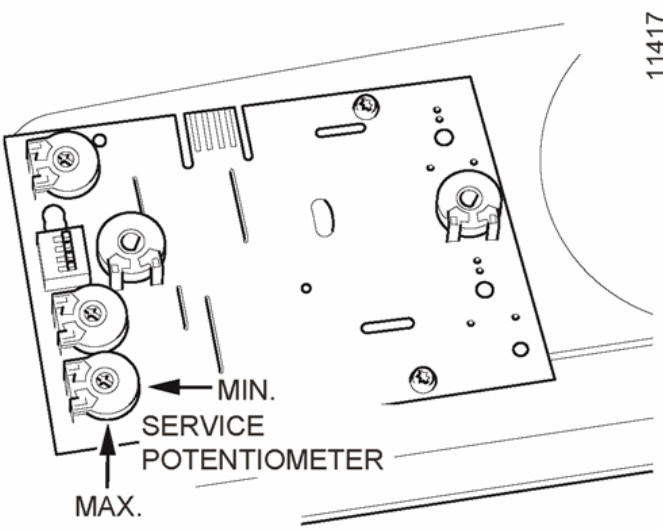
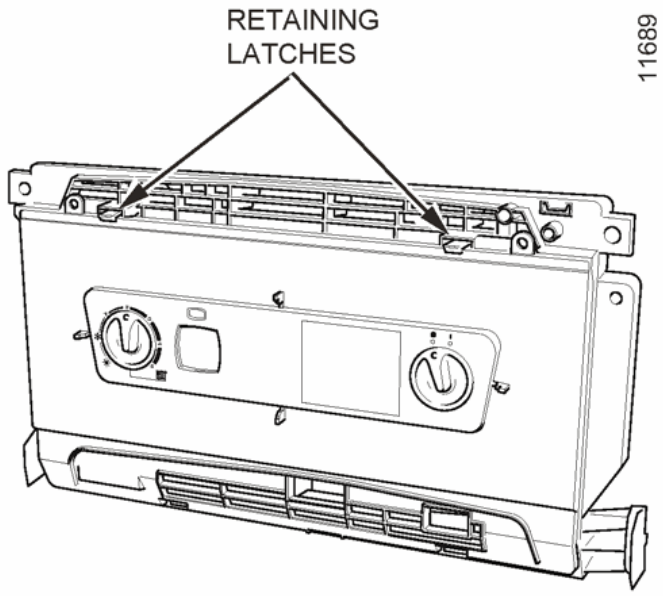

Diagram 12.6

Diagram 12.7



POTENTIOMETERS

Diagram 12.7

Diagram 12.8

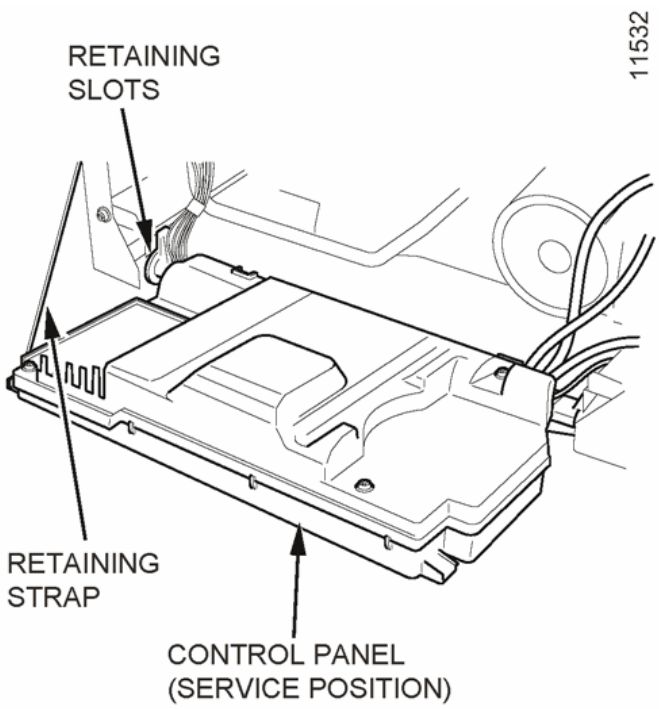

Diagram 12.8

Disconnect the gas supply at the gas service cock.

Remove the two gas pipe retaining clips, one located below gas valve and the other one located on the underside of the boiler chassis, see [diagram 12.4](#).

Pull sealing grommet down gas pipe, see [diagram 12.4](#).

Push the gas pipe upwards further into gas valve connection and then rotate anti-clockwise (looking down) until the gas pipe end is over the large hole in boiler chassis, see [diagram 12.4](#).

Withdraw the gas pipe from gas valve connection and remove.

NOTE:

When replacing ensure that the sealing grommet, situated below the gas valve is correctly re-seated.

Disconnect the gas control valve plug at the gas control valve.

Disconnect the electrical leads from the fan.

Remove the five combustion chamber front retaining nuts, see [diagram 12.5](#).

Gently remove the fan, gas control valve and burner assembly from the combustion chamber, see [diagram 12.3](#).

Clean the burner with a soft brush taking great care not to damage the front insulation. DO NOT use wire or sharp instruments to clean the holes of the burner.

Inspect the burner for any signs of damage.

Inspect the sealing rings and replace if necessary.

Removal of the burner is not necessary during a normal service.

12.4 Combustion Chamber and Heat Exchanger

Refer to [diagram 12.3](#).

Remove loose debris from combustion chamber using a soft brush and vacuum cleaner. Carefully flush by spraying water any remaining debris through the condensate trap (Ensure the water is kept away from electrical components).

12.5 Condensate Drain

Refer to [diagram 12.9](#).

Diagram 12.9

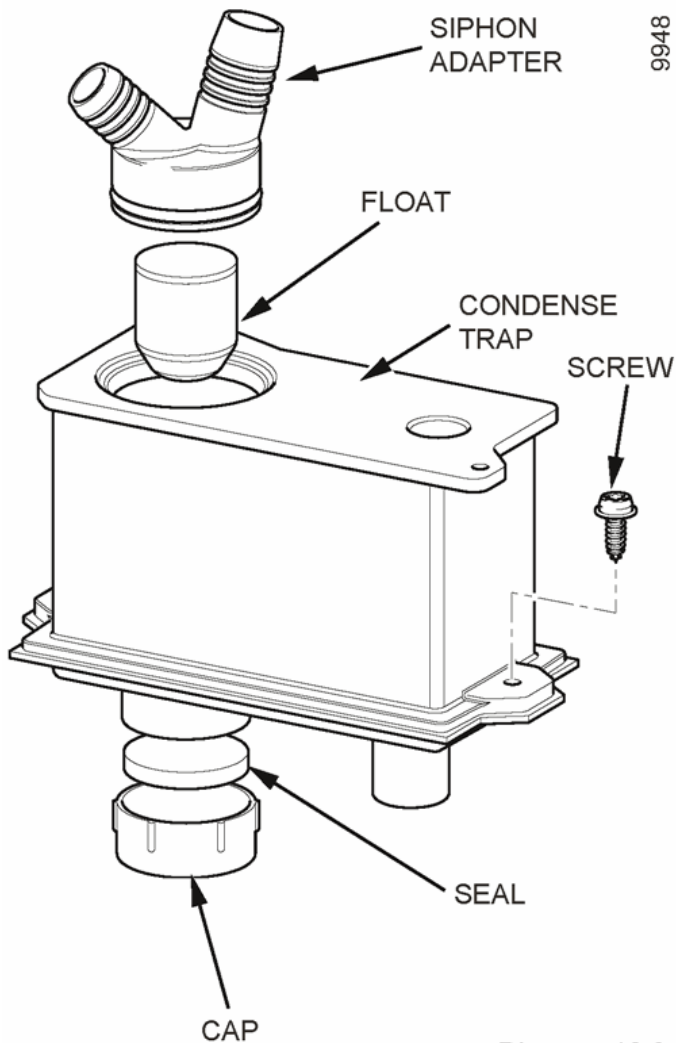

9948

Diagram 12.9

Remove DC fan supply, refer to [section 14.5](#).

Remove the clips securing the flexible tubes to the siphon adaptor by twisting the clips slightly to disengage the clip jaws from each other.

Remove black flexible tubes from siphon adaptor.

Lift off the siphon adaptor.

Remove the drain connection downstream of the condensate drain.

Remove the two condensate trap securing screws.

Lift up and carefully remove the condensate drain taking care not to spill any water which may be in the unit. As the unit is lifted remove the flexible connection on the outlet.

Remove the cap at the base of the condensate trap.

Remove any solids found.

Remove the float to clean it.

Flush water through the trap to remove any remaining solids.

Check for any debris in the outlet pipe of the condensate drain and clean as necessary.

Re-assemble and refit the condensate drain.

When refitting the cap ensure that a watertight seal is achieved, but do not use excessive force.

Remove siphon adaptor from flexible tubes.

Using a suitable container, flush the heat exchanger by spraying water until the water appears clear in the container.

Refit the siphon adaptor and flexible connections.

12.6 Combustion Check

Once the appliance has been re-assembled (apart from the front and inner casing panels) connect a CO₂ combustion analyser to the test point on the flue adaptor, see [diagram 12.1](#).

IMPORTANT:

Products of combustion will be discharged when the cap is removed. It is important to replace the cap immediately.

Turn on the gas service cock, see [diagram 8.1](#).

With the power off and the appliance cold, unclip the controls fascia and hinge it down to reveal the potentiometers on the rear of the User interface, see [diagram 12.7](#). Take care not to allow the fascia to drop down and damage the wiring.

Turn on the electrical supply.

Ensure external controls are calling for heat. The boiler should fire automatically.

Allow the boiler to fire for a minimum of 60 seconds and then, using an electrical screwdriver, rotate the service potentiometer fully clockwise. This will allow the digital display to indicate the 'flashing' fan speed on the appliance fascia.

In the fully clockwise position the display should be indicating the maximum fan speed of the appliance, 5400 rpm. Check the CO₂ value, which should be 8.8% ± 0.2%.

Note that with the inner case front panel fitted the combustion readings will increase slightly to 9.0% ± 0.3%.

If adjustment proves necessary then proceed as follows.

Refer to [diagram 12.6](#).

Adjust the maximum rate CO₂ by rotating the throttle to 8.8% in small incremental adjustments, then wait for the analyser to reflect the change before continuing to 8.8% (anti-clockwise to increase).

Rotate the service potentiometer fully anti-clockwise. Hold it in this position for about 5 seconds before rotating the service potentiometer clockwise to the mid-point or 3 o'clock position. The fan should reduce to 1200 rpm which will flash '12' on the LCD display.

Check the CO₂ value, which should be 8.8% ± 0.2%.

If adjustment proves necessary then proceed as follows.

Adjustment of the CO₂ at minimum rate is very coarse so carefully adjust the CO₂ with the offset adjustment to 8.8%, see [diagram 12.6](#).

Rotate the service potentiometer fully clockwise and recheck the maximum rate combustion, which should be 8.8% ± 0.2%.

After checking combustion rotate the service potentiometer fully anti-clockwise so that the display indicates the water temperature.

Replace the cap on the test point and refit the control cover rear panel.

12.7 Central Heating Filter

Turn off the electrical supply to the boiler.

Refer to [section 12.8](#) and drain the heating circuit of the boiler.

Remove the filter retaining clip and clean filter or renew if necessary, see [diagram 12.10](#).

Diagram 12.10

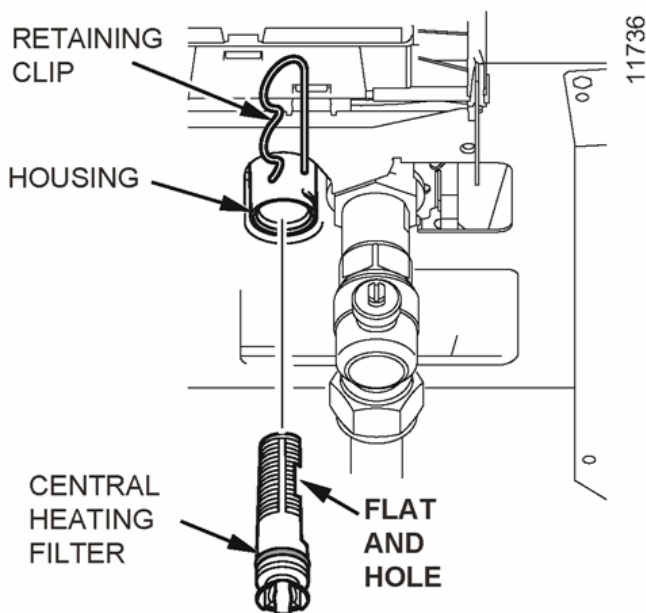

Diagram 12.10

Refit the filter, ensuring the correct orientation. The flat and hole in the filter positioned as shown in [diagram 12.10](#). Secure with retaining clip.

Open the heating flow and return isolating valves and refill, vent and pressurise the heating circuit. See [section 11.2](#).

Check for leaks.

12.8 Draining of Boiler Heating Circuit

Drain down the Heating Circuit only, by closing the heating flow and return isolating valves on the wall mounting jig, see [diagram 8.1](#).

Attach a length of hose to the drain point and open the drain valve, see [diagram 12.11](#).

Diagram 12.11

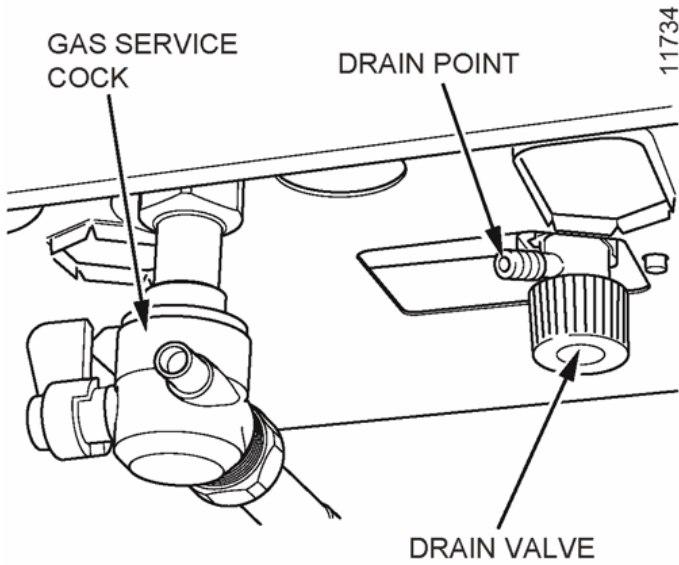

Diagram 12.11

After servicing or replacing parts, close the drain valve and remove the hose. Open the heating flow and return isolating valves and refill, vent and pressurise the heating circuit. See [section 11.2](#).

Check for leaks.

12.9 Inner Casing Panel Seal Check

Check the condition of the seal, replace as required.

To replace remove the old seal, thoroughly clean the casing surfaces. Fit the new seal, it is supplied to the correct length, see [diagram 12.12](#).

Diagram 12.12

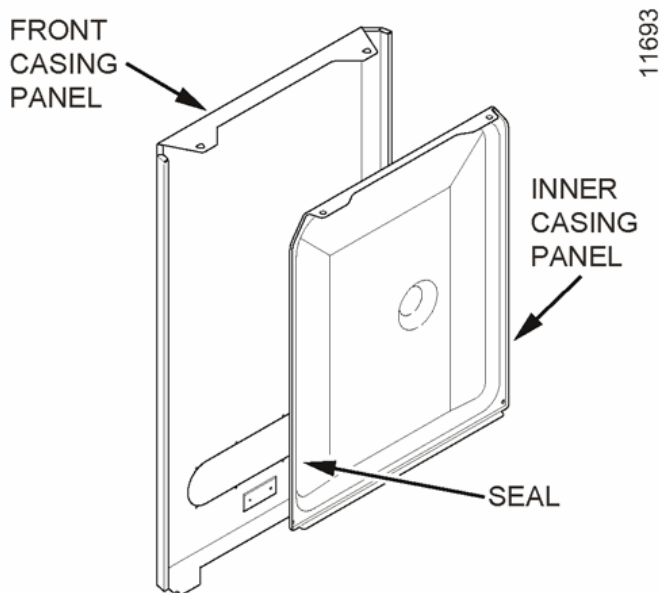

Diagram 12.12

13 Fault Finding

Diagram 13.1

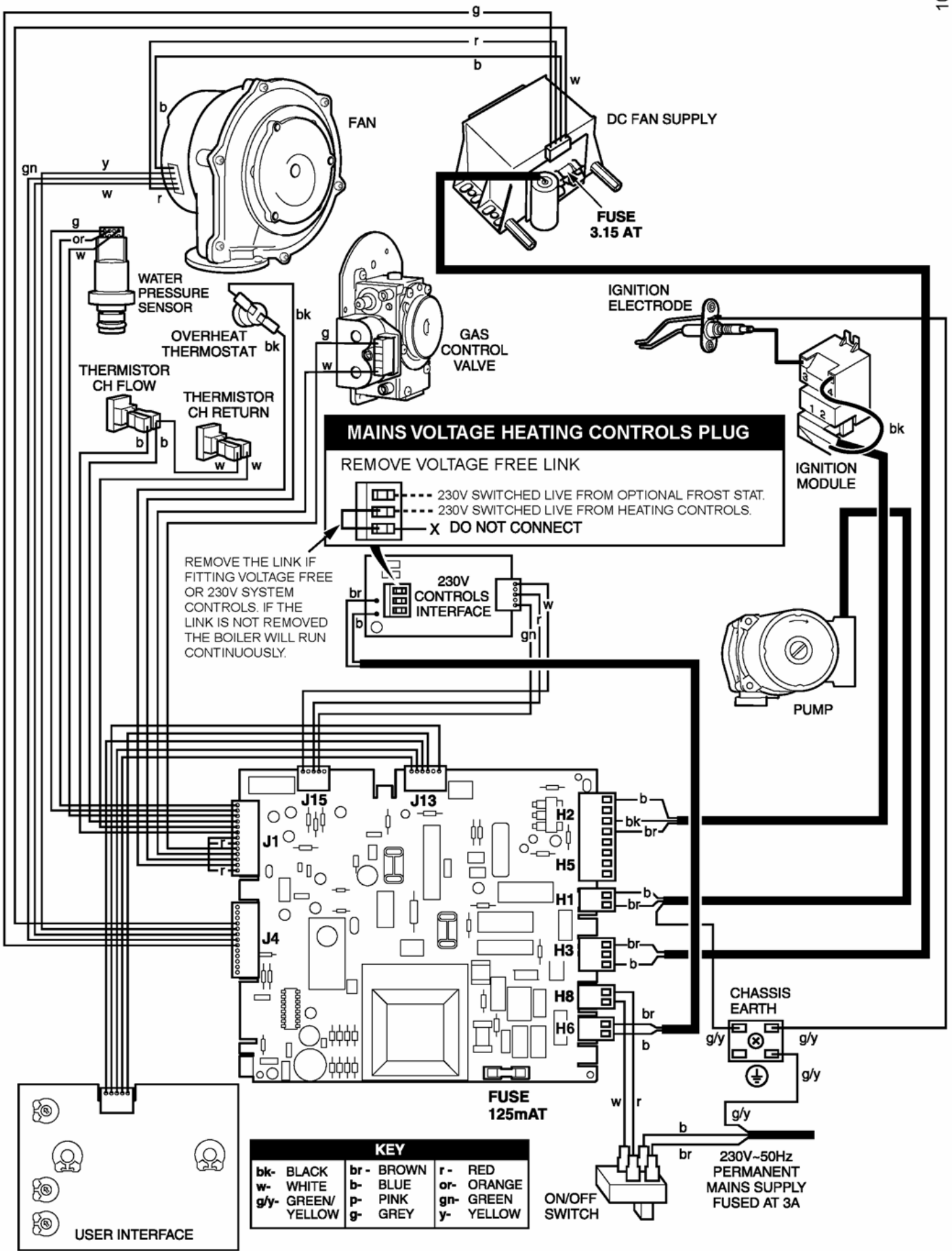

Diagram 13.1

Before trying to operate the boiler make sure that :

- All gas supply cocks are open and that the gas supply has been purged of air.
- There is a permanent mains supply to the boiler.
- There is a heating demand from the external controls.

WARNING:

Always isolate the boiler from the electrical supply before carrying out any electrical replacement work.

Always check for gas soundness after any service work.

Should there be any doubt about the voltage supply to any of the components, it is possible to carry out a simple electrical test to ensure all is operational in that area.

To carry out the electrical test, gain access to the Control Box PCB, as follows:

Hinge down the control box.

Remove Torx screws and unhook the rear panel.

For layout of PCB, see [diagram 13.1](#).

Diagram 13.2

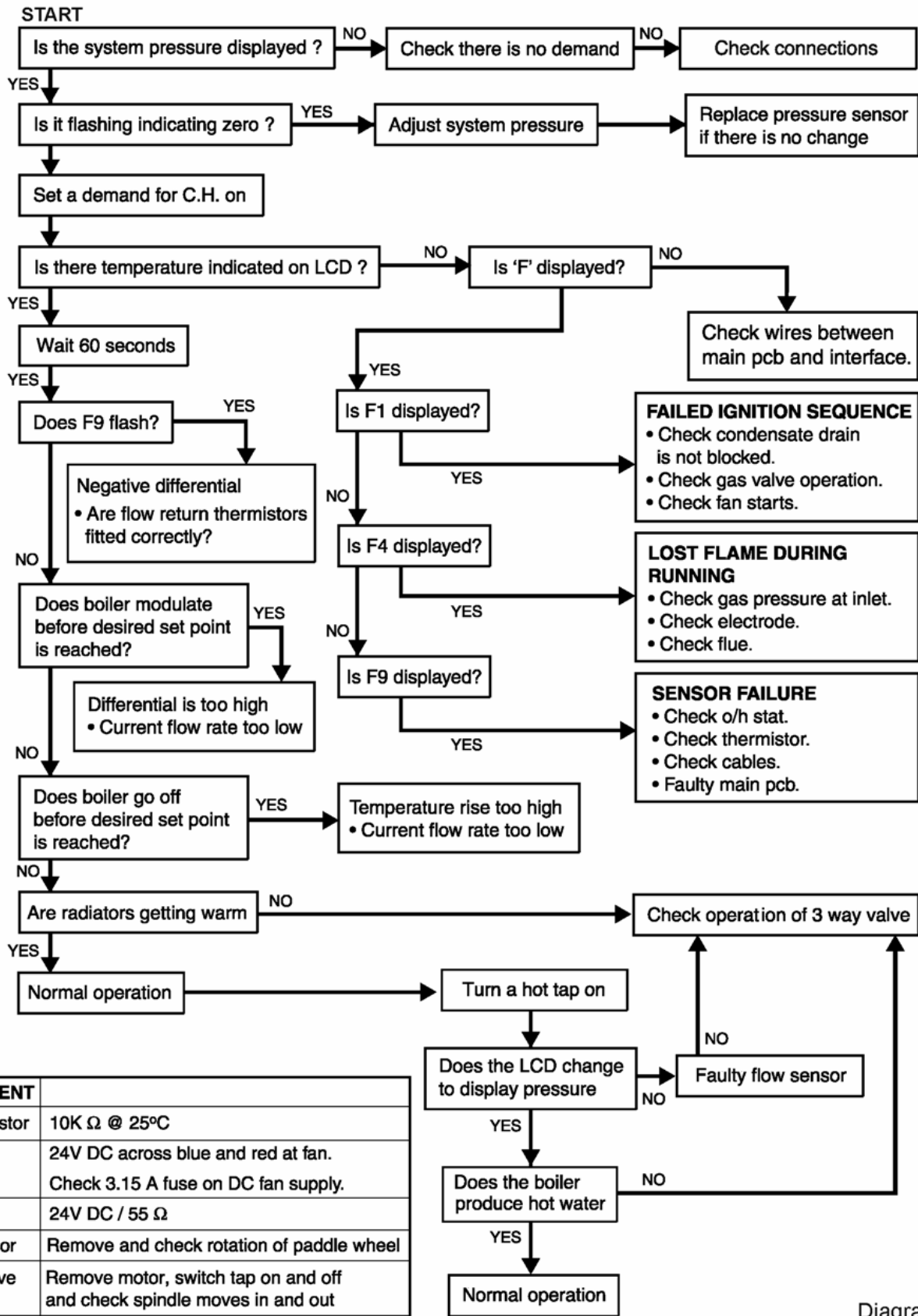

COMPONENT	
CH thermistor	10K Ω @ 25°C
Fan	24V DC across blue and red at fan. Check 3.15 A fuse on DC fan supply.
Gas Valve	24V DC / 55 Ω
Flow sensor	Remove and check rotation of paddle wheel
3 Way valve	Remove motor, switch tap on and off and check spindle moves in and out

Diagram 13.2

14 Replacement of Parts

14.1 General

Replacement of parts must be carried out by a competent person.

Before replacing any parts the boiler should be isolated from the mains electric supply and the gas should be turned off at the service cock on the boiler, see [diagram 8.1](#).

Unless stated otherwise parts are replaced in the reverse order to removal.

After replacing any parts always test for gas soundness and if necessary carry out functional test of the controls.

For replacement of parts the front casing and the inner casing panel of the boiler will need to be removed. To remove undo the two screws on the underside of the front casing and lift off. Undo the two screws on the front of the inner front panel and lift off.

The side panels can be hinged sideways to aid replacement of parts.

Undo and remove the three screws securing each side panel to the boiler, two at the front and one at the top.

14.2 Spark Electrode

For access, refer to [section 14.1](#).

Remove the spark plug lead, earth lead and two securing screws. Withdraw the spark electrode carefully from the combustion chamber, see [diagram 12.2](#).

14.3 Igniter Unit

For access, refer to [section 14.1](#).

Remove ignition lead and electrical connections, then remove igniter unit by removing two securing screws, see [diagram 14.1](#).

Diagram 14.1

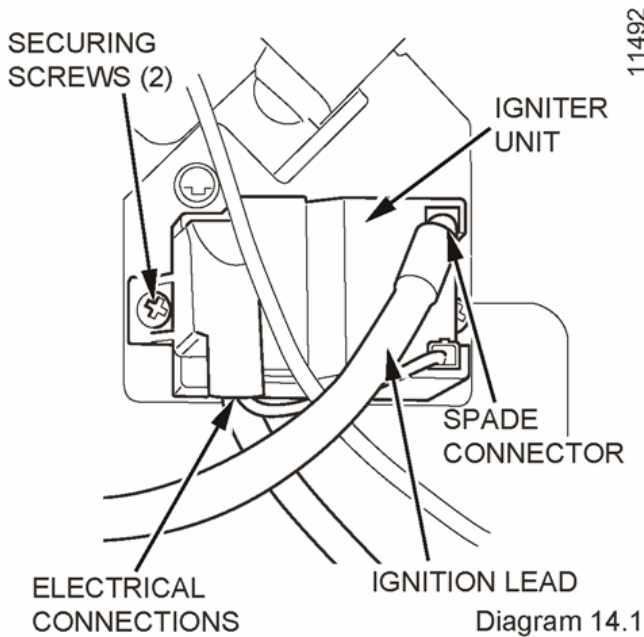

14.4 Ignition Lead

For access, refer to [section 14.1](#).

Refer to [diagram 12.5](#).

Pull the spark plug style connector off the spark electrode and the spade connector connected to the igniter unit, see [diagram 14.1](#).

14.5 DC Fan Supply

For access, refer to [section 14.1](#).

Refer to [diagram 14.2](#).

Diagram 14.2

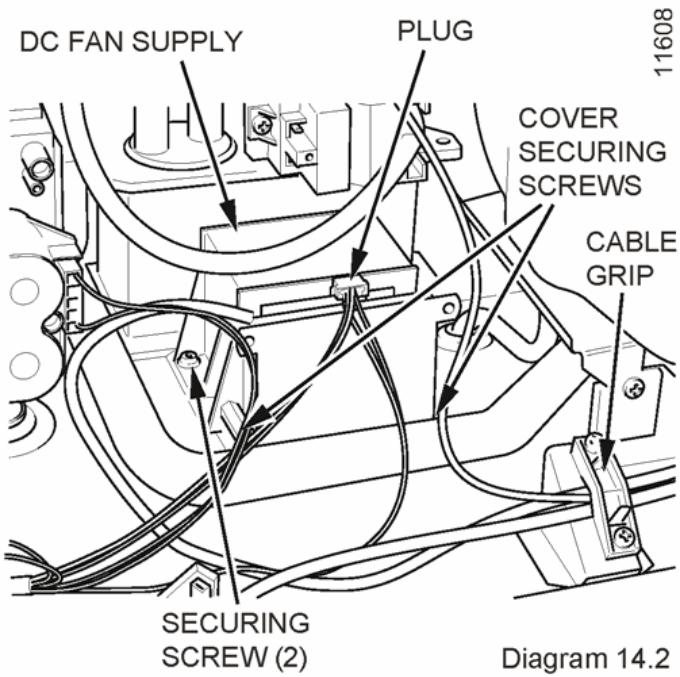

Diagram 14.2

Drop down control panel to the service position, see [diagram 14.23](#).

Unplug white plastic plug from DC fan supply.

Undo the three screws securing PCB rear cover and lift off.

Unplug DC fan supply lead from main PCB, see [diagram 14.3](#).

Diagram 14.3

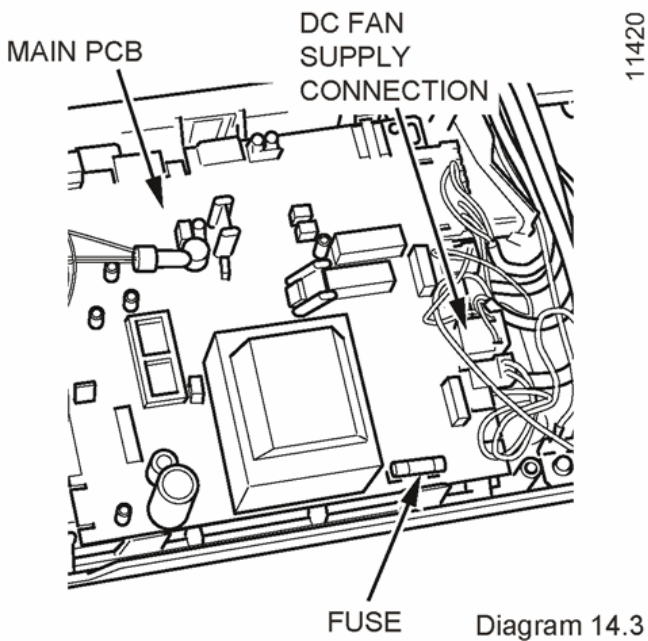

Diagram 14.3

Release cable grip located on boiler case.

Remove DC fan supply cable from retaining clip located to the right of cable grip.

Undo the two screws securing DC fan supply.

Hinge R/H side panel, refer to relevant part of [section 14.1](#).

Remove DC fan supply with lead.

14.6 Gas Control Valve

For access, refer to [section 14.1](#).

Remove the electrical plug from the gas control valve, see [diagram 14.4](#).

Diagram 14.4

11481

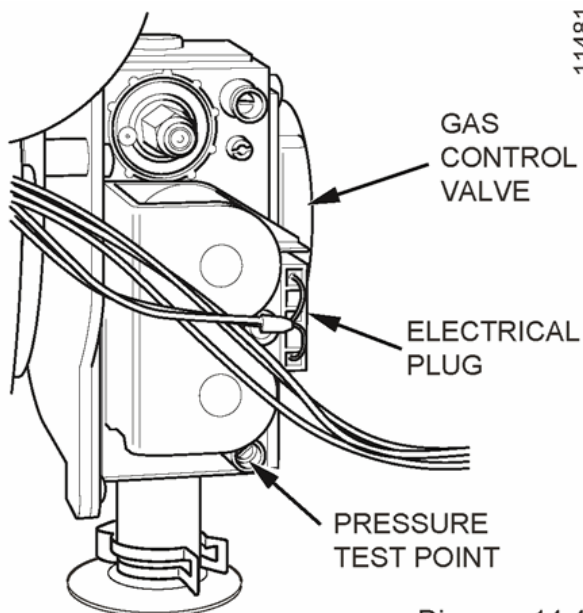

Diagram 14.4

Refer to [section 12.3](#) for removal of the fan, gas valve and burner assembly.

Before removing the gas valve note its position on the fan.

Remove the three securing screws, which fix the gas valve, plastic swirl plate to the venturi on the fan.

Remove the gas valve.

Remove the flexible gas supply pipe from the gas control valve.

When refitting the gas valve take care as it can be fitted more than one way.

After assembly test for gas soundness and purge in accordance with the current issue of BS6891 or in IE, the current edition of I.S.813 "Domestic Gas Installations".

14.7 Fan

For access, refer to [section 14.1](#).

Refer to [section 12.3](#) for removal of the fan gas valve and burner assembly.

Remove the gas control valve as described in the relevant parts of [section 14.6](#).

Remove the venturi plate secured with four screws and remove the two screws securing the fan to the gas manifold, see [diagram 14.5](#).

Diagram 14.5

11486

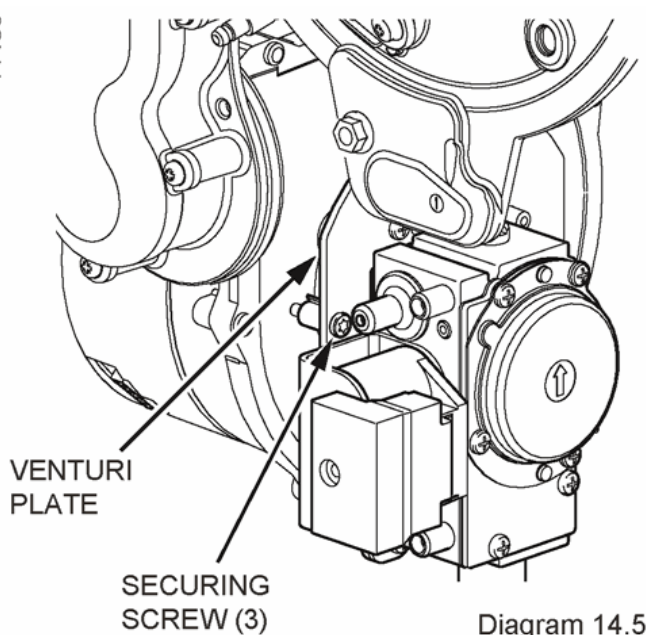

Diagram 14.5

Check the gasket and replace if necessary.

NOTE:

The Eden Sb fan is secured through an extension piece with two securing screws, check and replace any seals or gaskets if necessary.

14.8 Burner

NOTE:

THE BURNER WILL REQUIRE A NEW GASKET WHEN REFITTED.

For access, refer to [section 14.1](#).

Refer to [section 12.3](#) for removal of the fan, gas valve and burner assembly.

Remove the four screws that secure the burner, see [diagram 14.7](#).

Diagram 14.6

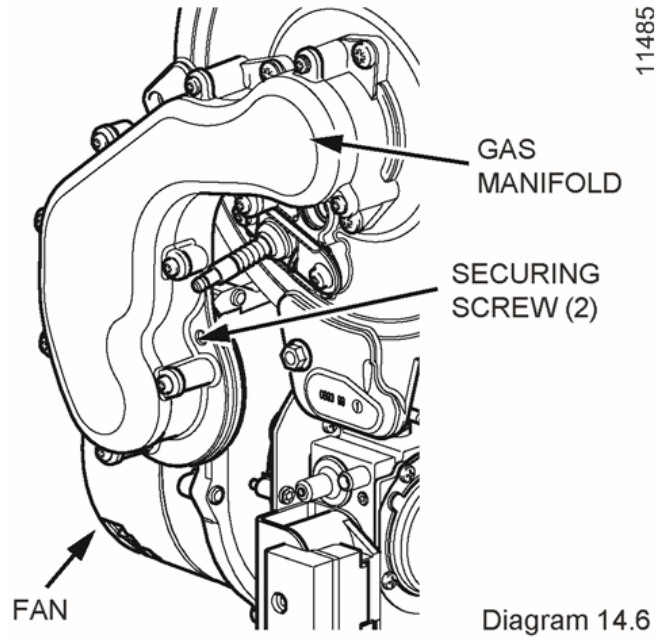
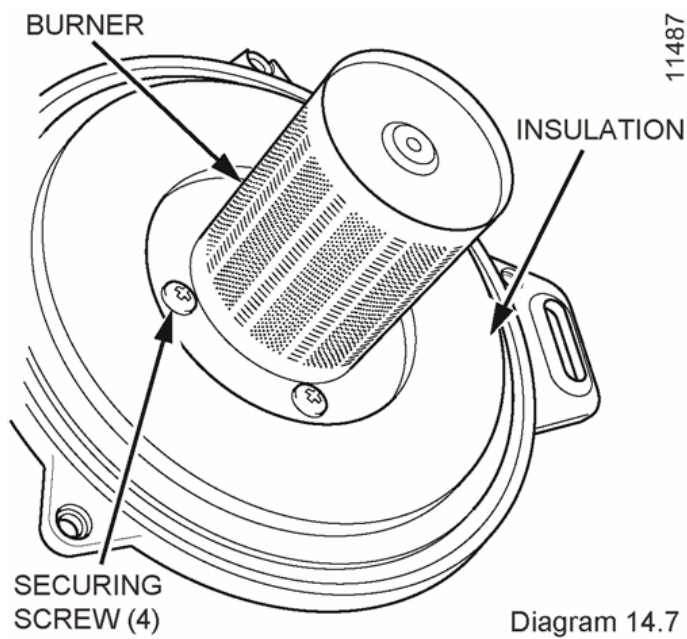

Diagram 14.7



14.9 Front Insulation

For access, refer to [section 14.1](#).

Refer to [section 12.3](#) for removal of the fan, gas valve and burner assembly.

Remove burner as per [section 14.8](#).

Remove spark electrode, see [section 14.2](#).

NOTE:

THE BURNER WILL REQUIRE A NEW GASKET WHEN REFITTED.

14.10 Rear Insulation

For access, refer to [section 14.1](#).

Refer to [section 12.3](#) for removal of the fan, gas valve and burner assembly.

Remove securing screw and washer in the centre of the insulation and withdraw insulation, see [diagram 14.8](#).

Diagram 14.8

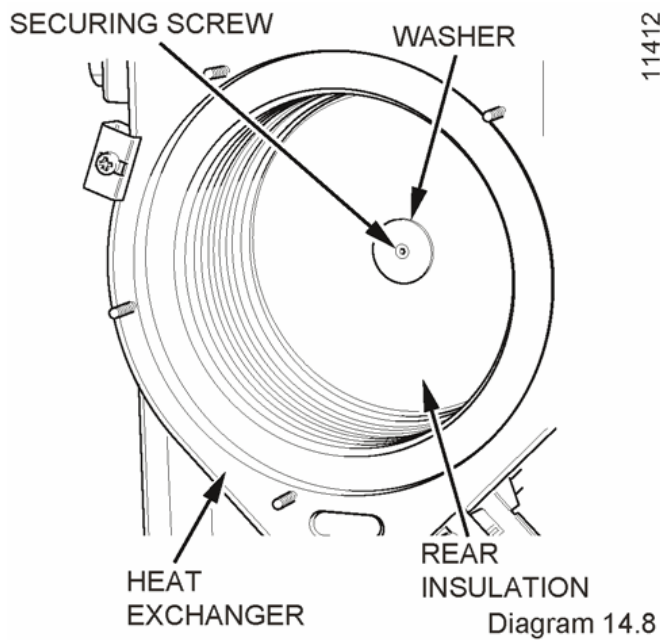

14.11 Viewing Window

For access, refer to [section 14.1](#).

Refer to [diagram 14.9](#).

Diagram 14.9

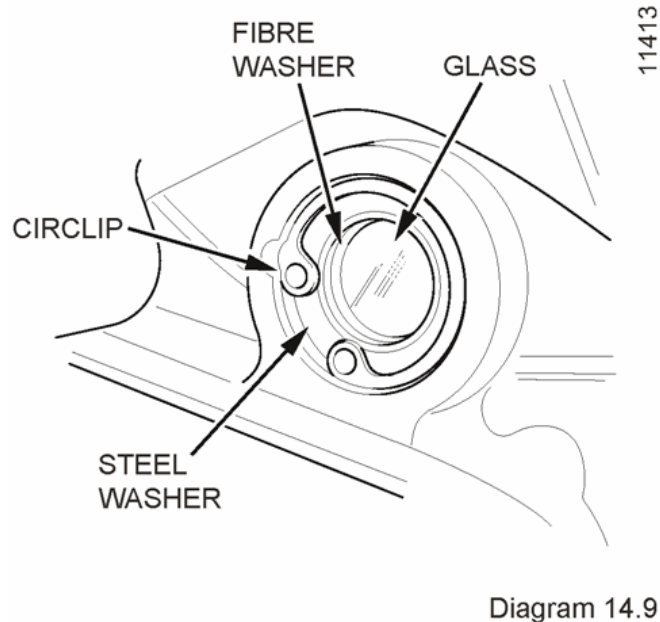

Remove circlip.

Remove steel washer.

Remove glass.

Remove fibre washer.

Replace in reverse order.

14.12 Expansion Vessel

For access, refer to [section 14.1](#).

Refer to [section 12.8](#) and drain the boiler heating circuit.

Undo the coupling at the base of the vessel, see [diagram 14.10](#).

Diagram 14.10

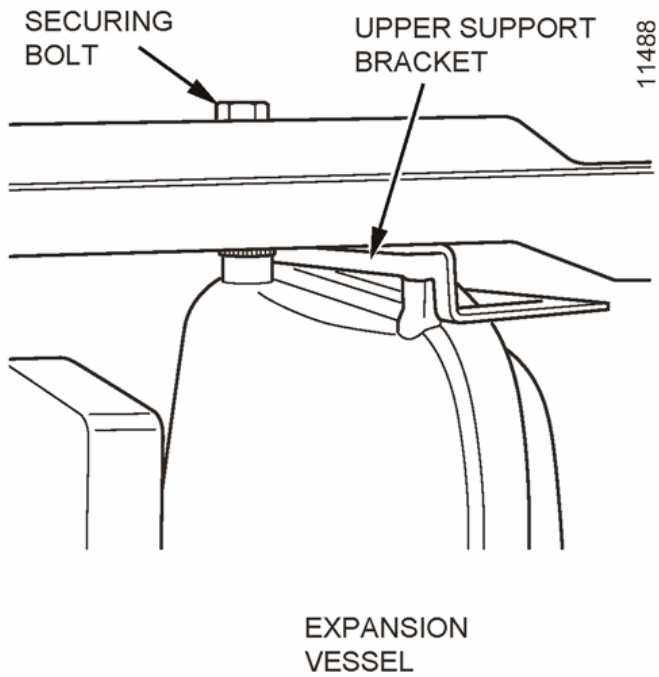

11488

11489

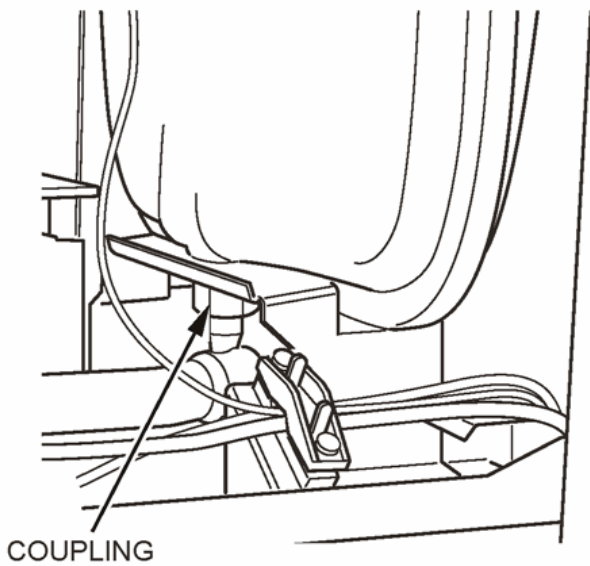

Diagram 14.10

While holding the vessel remove the securing bolt on the top panel of the boiler and upper support bracket on top of the expansion vessel.

Lift the vessel up, draw bottom out to the left, lower and remove.

Fit the replacement unit.

Refill, vent and pressurise the boiler.

Check for leaks.

14.13 Heat Exchanger

For access, refer to [section 14.1](#).

Refer to [section 12.3](#) for removal of the fan, gas valve and burner assembly.

Drain the boiler heating circuit, see [section 12.8](#).

Remove the clip securing the clear condense pipe to heat exchanger.

Pull to remove the condense pipe out of the bottom of the heat exchanger.

Undo the two nuts of the flow and return pipes from the heat exchanger.

Move the pipes away from the heat exchanger.

Loosen the three heat exchanger securing screws and clamps (two at the top and one at the bottom) to remove the heat exchanger, see [diagram 14.11](#).

Diagram 14.11

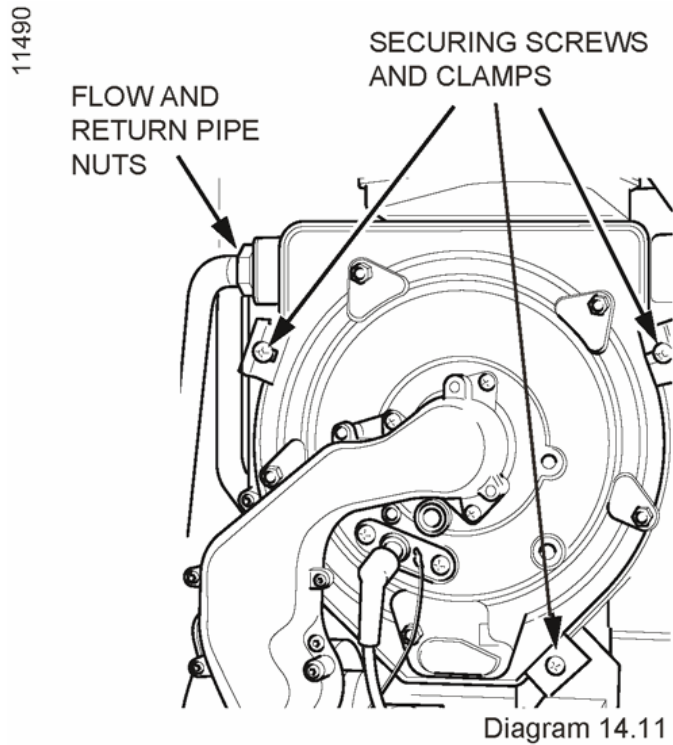

CAUTION:

There will be water in the heat exchanger.

Remove condense pipe connector from bottom of heat exchanger.

Carefully ease heat exchanger out.

14.14 Flue Hood

For access, refer to [section 14.1](#).

Refer to [diagram 14.12](#).

Diagram 14.12

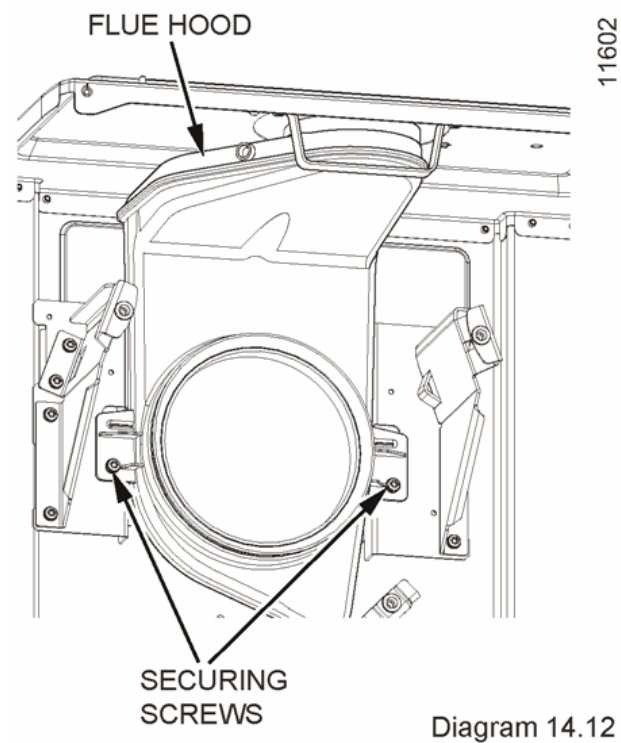

Remove heat exchanger as per [section 14.13](#).

Remove the two securing screws and pull the hood down and away from the flue hood bracket and flue elbow, see [diagram 14.12](#).

14.15 Pump (head only)

For access, refer to [section 14.1](#).

Refer to [section 12.8](#) and drain the boiler heating circuit.

Refer to [diagram 14.13](#).

Diagram 14.13

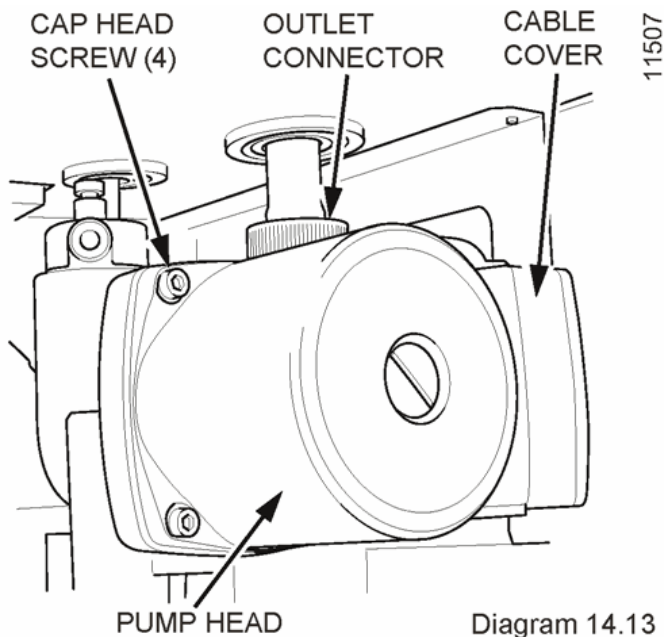

Remove the four cap head screws.

Carefully remove the pump head together with cable, do not strain cable.

Support the pump head, unscrew cable cover at the side of pump head and remove.

Disconnect wiring from pump head.

Reconnect wiring to new pump head and fit cover.

Fit the new pump head with 'o' ring.

Refill, vent and pressurise the boiler.

Check for leaks.

14.16 Safety Discharge Valve

For access, refer to [section 14.1](#).

Refer to [section 12.8](#) and drain the boiler heating circuit.

Refer to [diagram 14.14](#).

Diagram 14.14

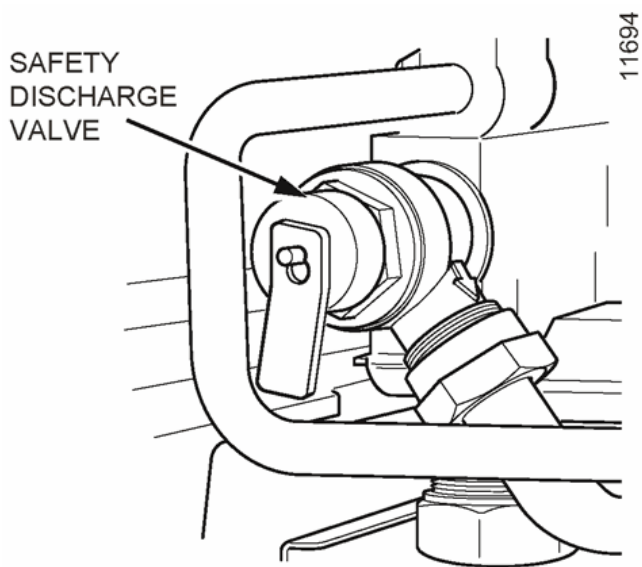

Diagram 14.14

Undo the safety discharge valve union and remove from the pipework.

Remove the securing clip and withdraw the safety discharge valve.

Refill, vent and pressurise the boiler.

Check for leaks.

14.17 Heating Flow Thermistor

For access, refer to [section 14.1](#).

Refer to [diagram 14.15](#).

Diagram 14.15

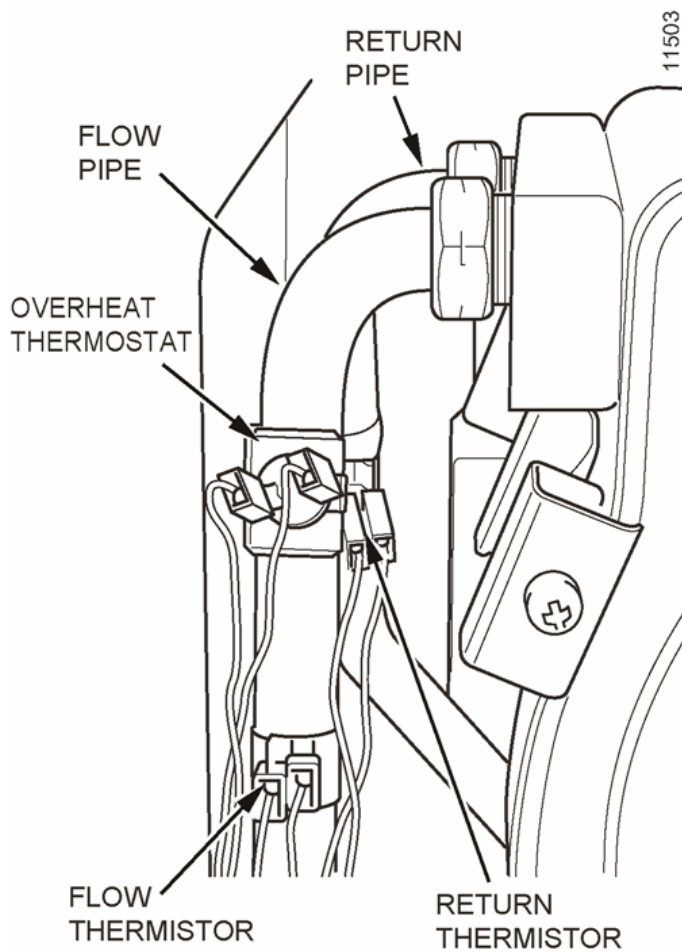

Diagram 14.15

Remove the electrical connections from the thermistor.

Remove the retaining clip from the flow pipe.

Remove the thermistor from the retaining clip.

Note that the polarity of the wiring to thermistors is unimportant.

14.18 Heating Return Thermistor

For access, refer to [section 14.1](#).

Refer to [diagram 14.15](#).

Remove the electrical connections from the thermistor.

Remove the retaining clip from the return pipe.

Remove the thermistor from the retaining clip.

Note that the polarity of the wiring to thermistor is unimportant.

14.19 Overheat Thermostat

For access, refer to [section 14.1](#).

Refer to [diagram 14.15](#).

Remove the electrical connections from the overheat stat.

Remove the retaining clip from the return pipe.

Remove the overheat stat from the retaining clip.

Ensure that the replacement thermostat is correctly located on the flat on the return pipe and carefully push the thermistor clip into place.

14.20 Automatic Air Vent

For access, refer to [section 14.1](#).

Refer to [section 12.8](#) and drain the boiler heating circuit.

Refer to [diagram 14.16](#).

Diagram 14.16

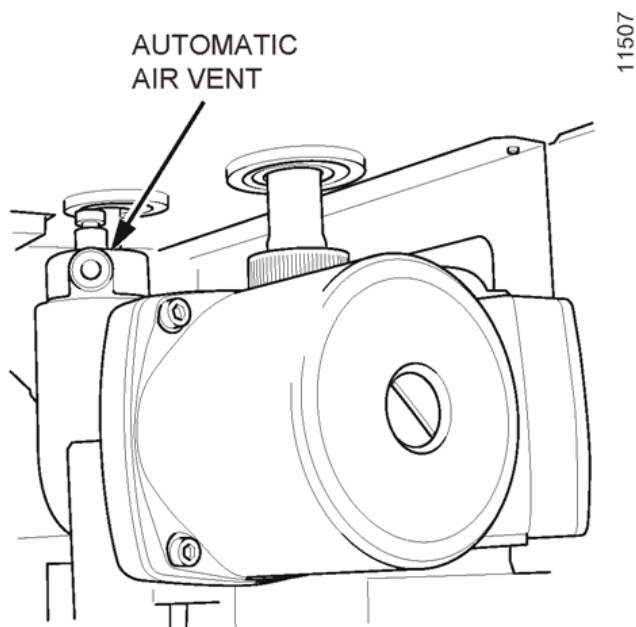

Diagram 14.16

Unscrew the automatic air vent.

Fit the new automatic air vent and 'o' ring ensuring the vent cap is left loose.

Refill, vent and pressurise the boiler.

Check for leaks.

14.21 Low Water Pressure Sensor

For access, refer to [section 14.1](#).

Refer to [section 12.8](#) and drain the boiler heating circuit. Refer to [diagram 14.17](#).

Diagram 14.17

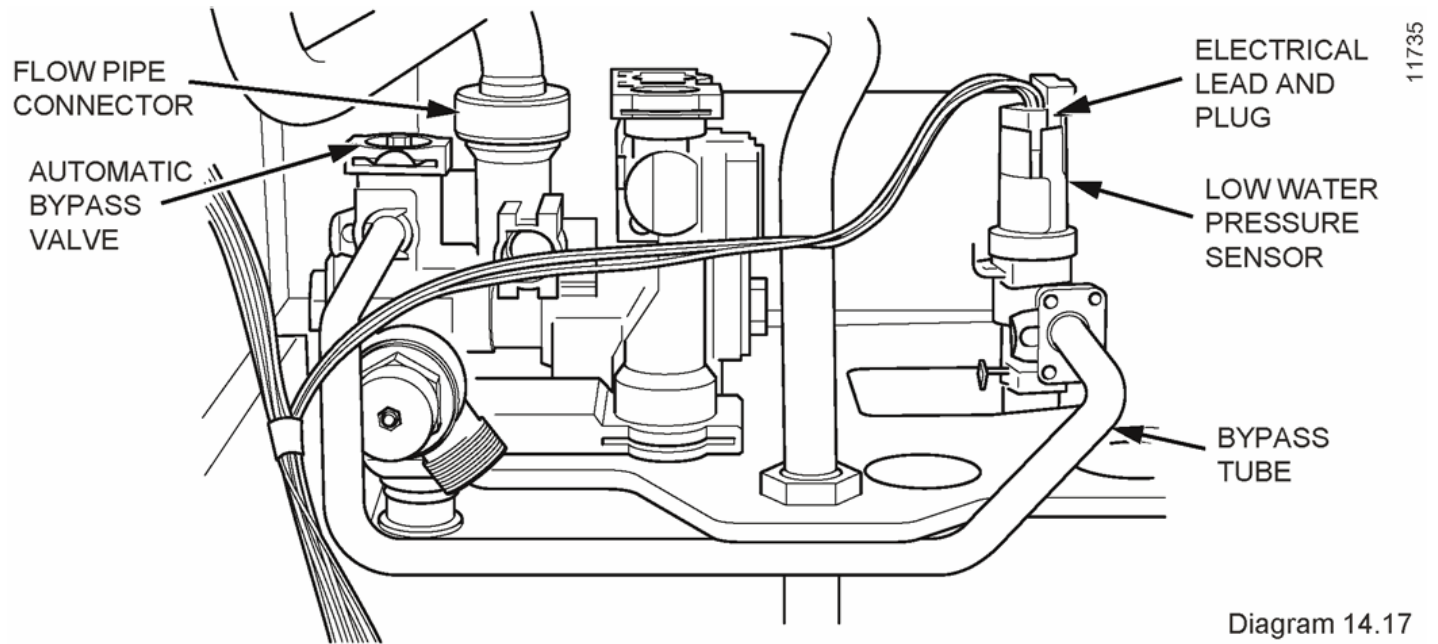

Diagram 14.17

Disconnect the electrical lead by pushing up retaining tab and withdraw lead plug.

Remove the retaining clip to remove the low water pressure sensor.

Fit the new low water pressure sensor. Refill vent and pressurise the boiler.

Check for leaks.

14.22 Bypass Tube

For access, refer to [section 14.1](#).

Refer to [section 12.8](#) and drain the boiler heating circuit.

Refer to [diagram 14.17](#).

Remove the retaining clips to remove the bypass tube.

Replace the bypass tube, refill, vent and pressurise the boiler.

Check for leaks.

14.23 Automatic Bypass Valve

For access, refer to [section 14.1](#).

Refer to [section 12.8](#) and drain the boiler heating circuit.

Refer to [diagram 14.17](#).

Remove the retaining clip to remove the bypass valve.

Replace the reduced pressure zone valve, refill, vent and pressurise the boiler.

Check for leaks.

14.24 Central Heating Filter

Refer to [section 12.7](#).

14.25 Heating Circuit Drain Point

Refer to [section 12.8](#) to drain the boiler heating circuit. Refer to [diagram 14.18](#).

Diagram 14.18

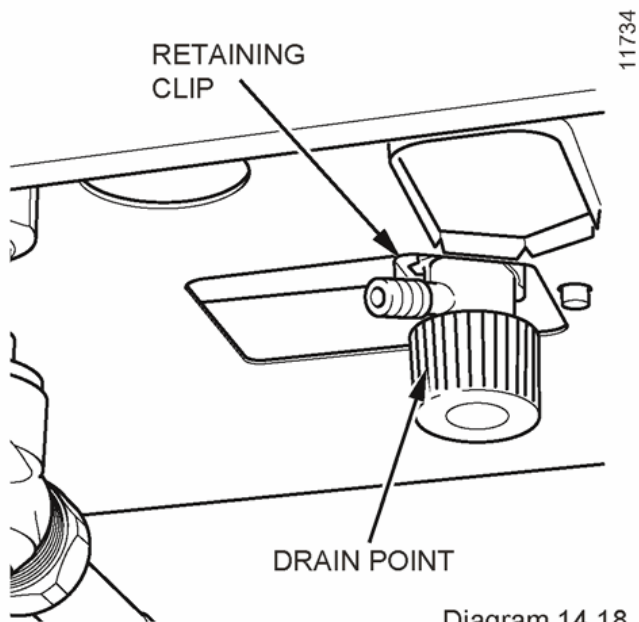

11734

Diagram 14.18

Remove the retaining clip to remove the drain point.

Replace the draining point, refill, vent and pressurise the boiler.

Check for leaks.

14.26 Inner Casing Panel Seal

For access, refer to [section 14.1](#).

Refer to [diagram 14.19](#).

Diagram 14.19

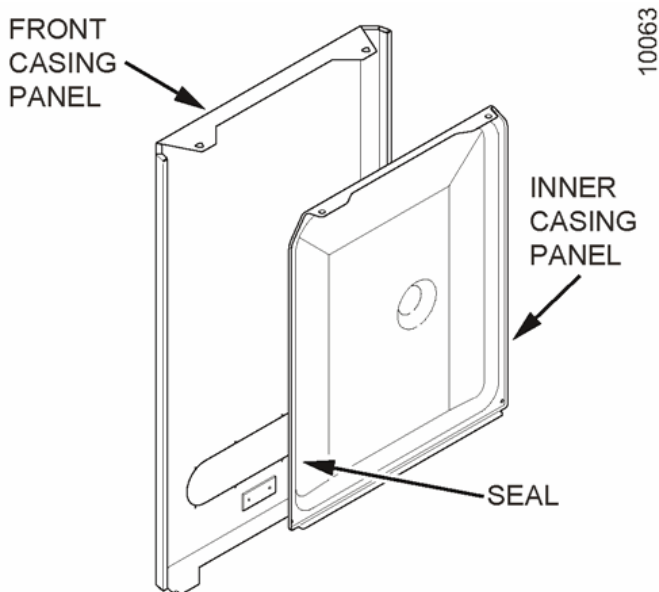

10063

Diagram 14.19

Remove the inner casing panel.

To replace remove the old seal, thoroughly clean the casing surfaces. Fit the new seal, it is supplied to the correct length.

Refit the inner casing panel.

NOTE:

Ensure the seal is fitted correctly giving an airtight joint.

14.27 Condense Drain

For access, refer to [section 14.1](#).

Refer to [section 12.5](#).

14.28 Hydroblock Assembly Left-Hand

Refer to [section 12.8](#) to drain the boiler heating circuit.

Refer to [diagram 14.17](#).

Undo the connector on the bottom of the flow pipe from the hydroblock.

Undo the nut connecting flow pipe to heat exchanger.

Lift the flow pipe up out of the way.

Remove the bypass tube, refer to [section 14.22](#).

Undo the safety discharge valve union and remove the pipework.

Remove the securing clip and withdraw the safety discharge valve, refer to [section 14.16](#).

Remove securing clip 1 below hydroblock, see [diagram 14.20](#).

Diagram 14.20

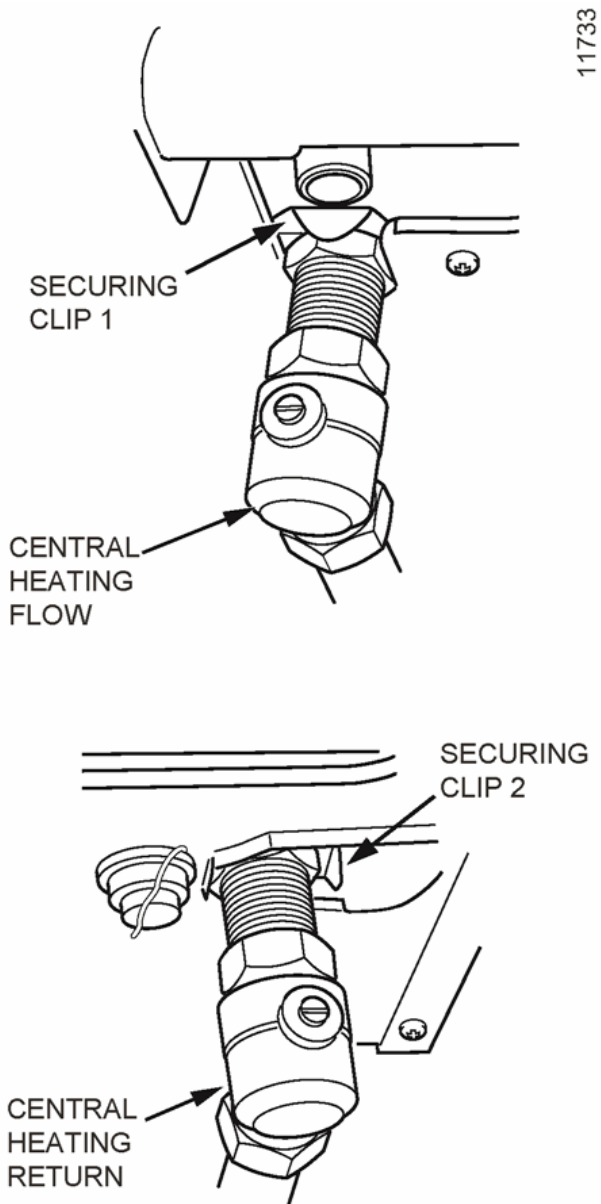

Diagram 14.20

Undo three securing screws on the underside of the left-hand hydroblock.

Remove screw in back plate. Lift out the left hand hydroblock.

Remove any remaining components for refitting into the replacement left hand hydroblock.

Refill, vent and pressurise the boiler.

Check for any leaks.

14.29 Hydroblock Assembly Right-Hand

For access, refer to [section 14.1](#).

Refer to [section 12.8](#) to drain the boiler heating circuit.

Refer to [diagram 14.17](#).

Undo the connector on the bottom of the return pipe from the hydroblock.

Undo the nut connecting return pipe to heat exchanger.

Lift the return pipe up out of the way.

Undo the coupling at the base of the expansion vessel, see [diagram 14.10](#).

Remove the clip holding the expansion vessel coupling into the top of the right hand hydroblock.

Move the coupling out of the way.

Remove pump head, refer to [section 14.15](#).

NOTE:

It is not necessary to disconnect the electrical lead but put pump head in a convenient place where it will not strain the lead.

Remove the bypass tube, refer to [section 14.22](#).

Remove the electrical connection to the low water pressure sensor, refer to [section 14.21](#).

Remove the water connection clip 2 below the hydroblock, see [diagram 14.20](#).

Remove the central heating filter, refer to [section 12.7](#).

Remove the retaining clip to remove the drain point, refer to [section 14.25](#).

Undo two securing screws on underside of the right hand hydroblock.

Remove screw in back plate.

Lift out the right hand hydroblock.

Remove the remaining components for refitting into the replacement right hand hydroblock.

Refill, vent and pressurise the boiler.

Check for leaks.

14.30 Access to Switches, User Interface and Timer (if fitted)

For access, refer to [section 14.1](#).

Release the front of the fascia by carefully prising up the two retaining latches, see [diagram 14.21](#).

Diagram 14.21

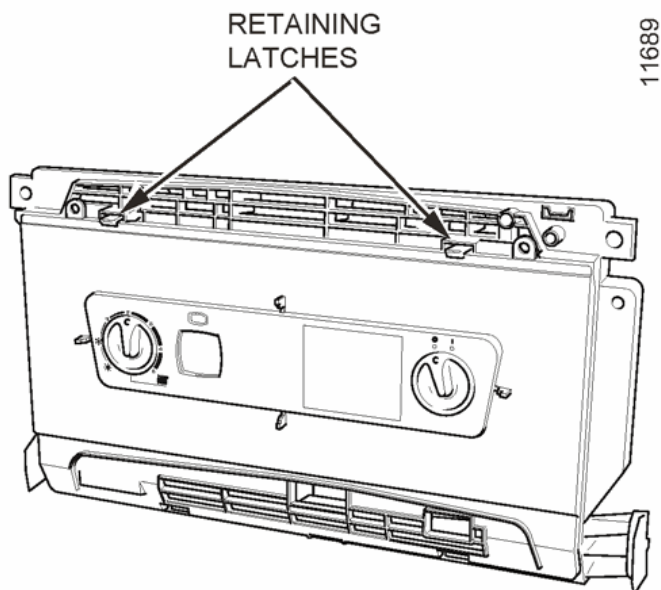

Diagram 14.21

Do not allow the front of the fascia to swing down and be loosely held by the electrical connections to the mains/reset switch, user interface and clock. Either remove the connections or support the fascia.

14.31 Mains/Reset Switch

Refer to [section 14.30](#) for access and [diagram 14.22](#).

Diagram 14.22

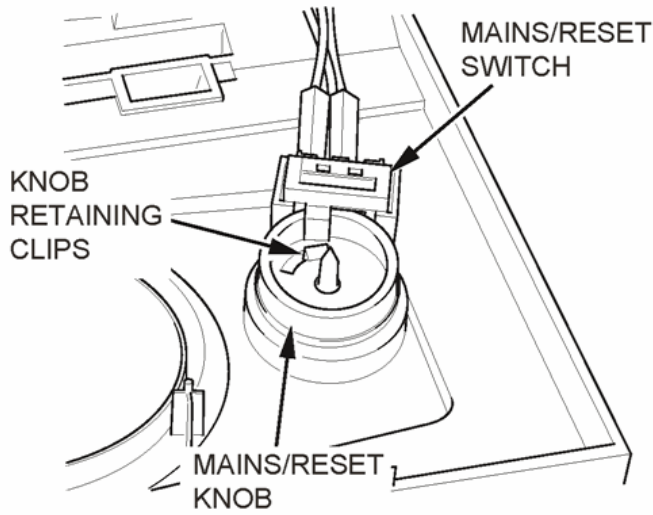

Diagram 14.22

Remove the switch retaining screw.

Remove switch from housing.

Remove electrical leads.

14.32 Mains/Reset Knob

Refer to [section 14.30](#) for access.

Remove actuator by springing back retaining clips, see [diagram 14.22](#).

Spring back knob retaining clips and push knob out from the back.

14.33 User Interface/Display Unit PCB

Refer to [section 14.30](#) for access and [diagram 14.24](#).

Diagram 14.23

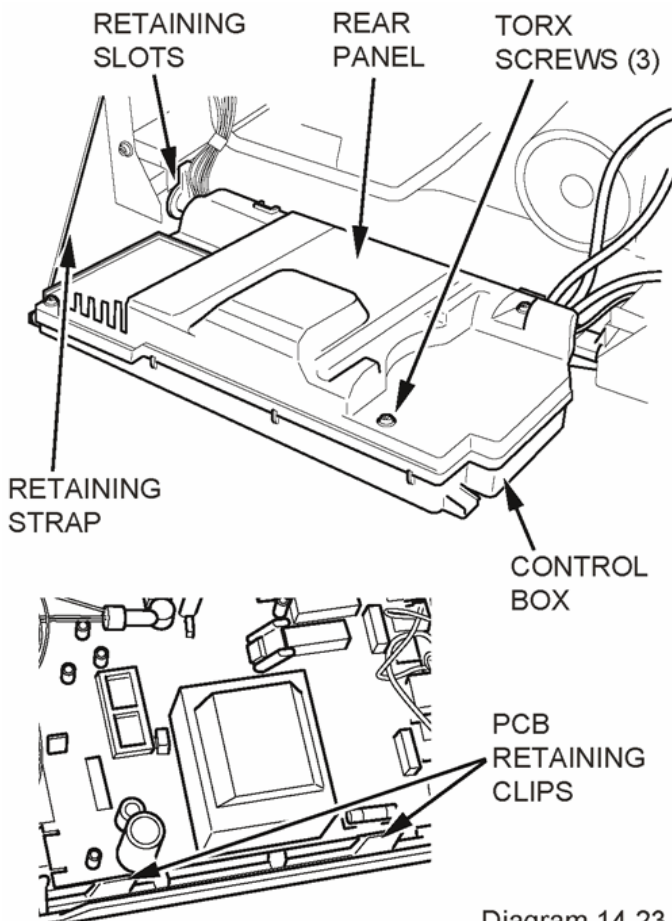
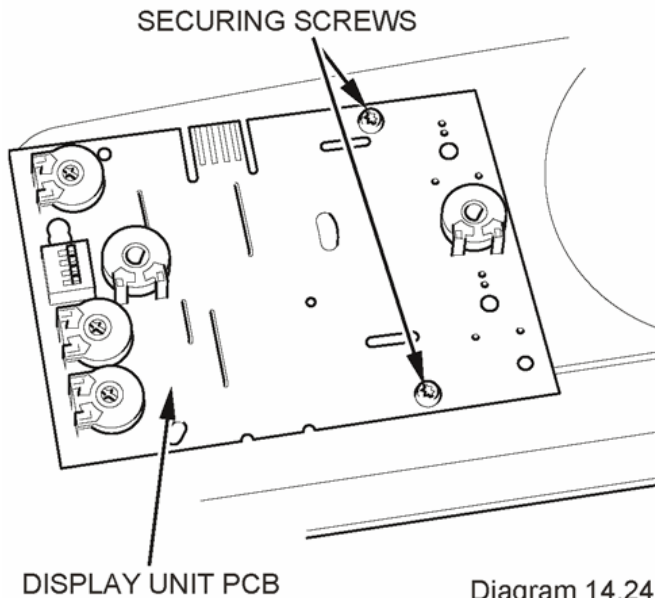

Diagram 14.23

Diagram 14.24



Remove electrical plug.

Remove the two securing screws.

Withdraw the board.

When replacing the board refer to instructions supplied with replacement PCB on setting it up.

14.34 Control Box PCB

For access, refer to [section 14.1](#).

Hinge down the control box.

Remove three TORX screws and unhook the rear panel.

Remove the electrical connections to the PCB.

Prise back the two PCB retaining clips and withdraw the PCB.

When refitting the rear panel ensure the leads are not trapped, refer to [diagram 14.3](#).

14.35 Control Box

For access, refer to [section 14.34](#).

Remove relevant plugs and connectors, refer to wiring [diagram 13.1](#).

Withdraw grommets and leads so they are hanging loose.

Unthread the retaining strap and remove the control box by drawing it outwards away from its retaining slots, see [diagram 14.23](#).

14.36 Fuses

PCB - Control Box

For access, refer to [section 14.34](#).

The fuse (rated 125mAT) is located at bottom right hand side of the PCB, see [diagram 13.1](#)

PCB - DC Fan Supply

For access, refer to [section 14.1](#).

Refer to [diagram 14.2](#) and wiring [diagram 13.1](#).

Undo the two screws securing the front cover of the DC Fan Supply and remove.

The fuse (rated 3.15AT) is located near the centre of the PCB.

14.37 230V Controls Interface

For access, refer to [section 14.30](#).

Disconnect the electrical connection from the 230V controls board and the electrical connection from the Control box PCB, see [diagram 14.25](#).

Diagram 14.25

230V CONTROLS
INTERFACE BOARD

11419

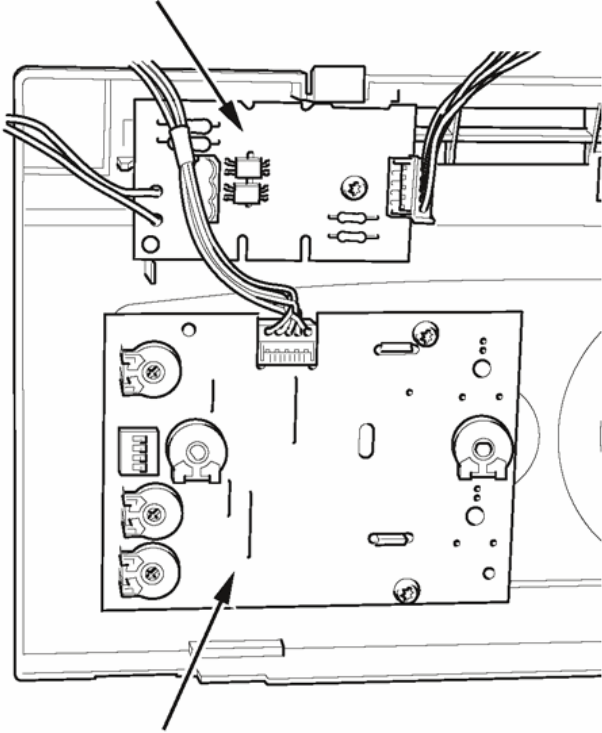

DISPLAY UNIT
PCB

Diagram 14.25

Remove the 230V controls interface retaining screw.

Remove the 230V controls interface board.