

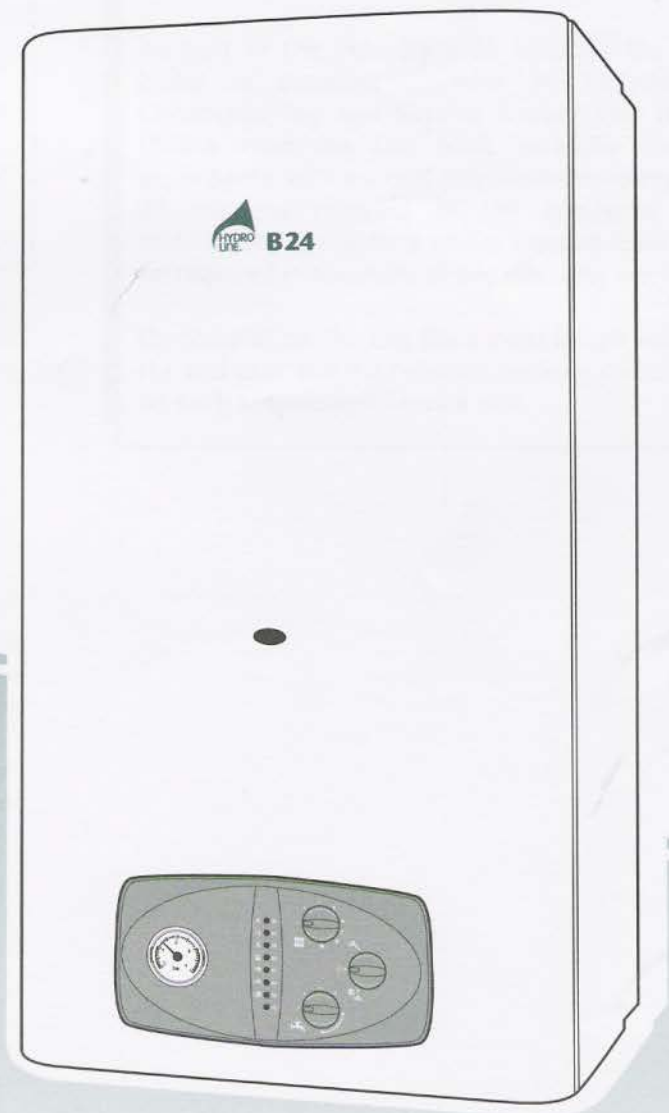

B24

**Condensing
Wall Mounted
Combination Boiler**

**Installation,
Servicing
&
User Instructions**



Natural Gas / LPG

Hydroline B24
Condensing Combination Boilers

British Gas Service Listing
This boiler has been 'Service Listed' by British Gas
and has been designated with the following
G.C No. 47-157-18



The Hydroline™ central heating boiler is manufactured from high quality materials, enabling reliability and optimum performance.

Hydroline™ is committed to the continual development of their appliances to ensure their customers benefit from the latest advances in combustion technology and energy savings.

'Benchmark' Log Book

As part of the industry-wide initiative the B24 boiler is supplied with an Installation, Commissioning and Service Record Log Book. Please read the Log book carefully and in accordance with current requirements complete all sections relevant to the appliance and installation. The details within the Log Book will be required in the event of any warranty work.

On completion, the Log Book must be left with the end user and the relevant sections completed on each subsequent Service visit.

Type test for purpose of EEC Regulations certified by:

Notified Body IMQ

51BP2727	CE Directive 90/396/EEC
51BP2728DR	CE Directive 92/42/EEC
	CE Directive 73/23/EEC
	CE Directive 89/396 EEC
	(modified from 93/68)

The manufacturer, in the continuous process to improve his products, reserves the right to modify the data expressed in the present documentation at any time and without prior notice.

The present documentation is an informative support and it cannot be considered as a contract towards third parties.

Contents

Section	Page
Preface	2
The Signs on Box	3
The Signs on Boiler	3
1. Installation Regulations	4
2. Technical Data	5
3. Boiler Characteristics	7
4. Operation	7
5. General Installation	8
6. Appliance Siting	10
7. Flue Terminal Location	10
8. General Flue Info	12
9. Electrical Connections	13
10. Boiler Installation	15
11. Gas Supply	16
12. Filling the System	17
13. Control Panel Functions	17
14. Commissioning	18
15. Onboard Adjustments	18
16. Safety Devices	19
17. Fault Finding Chart	20
18. Routine Servicing	22
19. Component Replacement	24
20. Gas Type Conversion	32
Appendices	
Spare Parts List	33
User Instructions	34
Benchmark Log Book	38- 39

Preface

The Hydroline™ gas fired, condensing combination boiler meets the requirements of all appropriate regulations and is deemed to meet the requirements of:

- Gas Appliance Directive 90/396/EEC
- Efficiency Directive 92/42/EEC
- Low Voltage Directive 73/23 EEC (modified from 93/68)
- Electromagnetic Compatibility Directive 89/396 EEC (modified from 93/68)

Hydroline™ declares that the materials used in the manufacturer of this appliance are non-hazardous and that no substances harmful to health are contained within the appliance.

Manual Handling:

As this appliance is heavy it is recommended that you get assistance when lifting. When manoeuvring the boiler always use safe techniques – keep your back straight, bend your knees, don't twist, move your feet. Avoid bending forwards or sideways and keep the load as close to your body as possible. Where possible transport the boiler using a suitable trolley, sack truck or get some assistance. Grip the boiler firmly and before lifting establish where the weight is concentrated to determine the centre of gravity, repositioning yourself if necessary

Warnings

Hydroline™ accepts no responsibility for the unsatisfactory performance of the appliance or flue arising from the failure to comply with the installation and user instructions. Incorrect installation could invalidate your guarantee and may lead to prosecution.

If the boiler is sold to another customer, all documents must be transferred from existing customer to the new one and the appliance must be re-registered with Hydroline in order to maintain the guarantee.

The boiler must be installed in accordance with these instructions and all the regulations currently in force. Read these instructions carefully before installing or using the appliance.

SHOULD YOU SMELL GAS: Turn the gas valve off at the Gas Meter or Gas Cylinder, ventilate the room by opening windows and doors (EXTINGUISH ANY NAKED FLAMES, DO NOT OPERATE ANY ELECTRICAL SWITCHES) and call Transco on 0800 111 999 or if you use LPG call your gas supplier.

IMPORTANT NOTE

Speed 2 is the factory default setting for the Pump.
This setting should be suitable for most of your applications.

IMPORTANT

Installation of the Condensate Waste Hose

The condensate trap bottom part should be filled with 50 cc. of water before operating the boiler.

1. When the boiler is mounted push the plastic hose supplied all the way onto the condensate outlet to the bottom left hand corner of the boiler as shown in the diagram.
2. Cut the plastic hose to desired length and fit a plastic coupling to connect to your plastic waste pipe.

NOTE: Removal of the condensate trap for cleaning purposes.

1. Pull off the plastic hose from the condensate trap.
2. Unscrew the bottom of the trap in an anti-clockwise direction by hand. Note if the trap has become stuck there is a hexagonal socket in the bottom of the trap to enable an allen-key to be used.

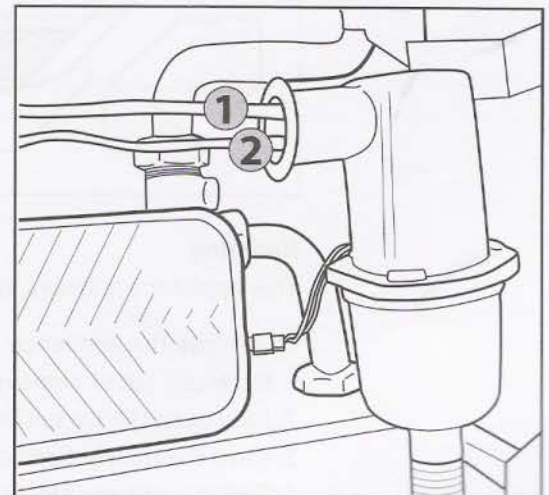

* The accessory for the condensate trap includes the hose.

NOTE: Cables on the cap ; 1- Ionisation cable
2 - Earth cable

The Signs on Box



The sign of approval B 24 boiler has been certified by IMQ Italy.



This is a fragile piece of equipment: Do not drop.



Avoid getting the box damp or wet.



The packed appliances may be stacked three high.



Do not crush the packaging as this may damage the appliance.



Store the appliance upright as indicated on the box.

The Signs on Boiler

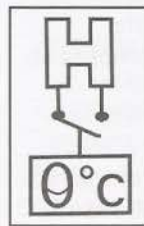

This picture shows the terminal block, which is located at the bottom left hand side of the control panel cover, to which a voltage free room thermostat may be fitted. NOTE: This is a voltage free connection and no power must be applied to these terminals. For mains powered thermostat connection, see section 9.5.



Warning! High Voltage: This sign is located on the back of the control box housing warning of high voltages within the control box. Turn off and isolate the appliance before removing this cover.

NOTE: Take care as there may be residual voltage within some components



Potentiometer Cover: Removal of the cover, which is found on the back of the control box, gives access to the adjustment potentiometers. NOTE: Do not make any adjustments without reading the instructions carefully.

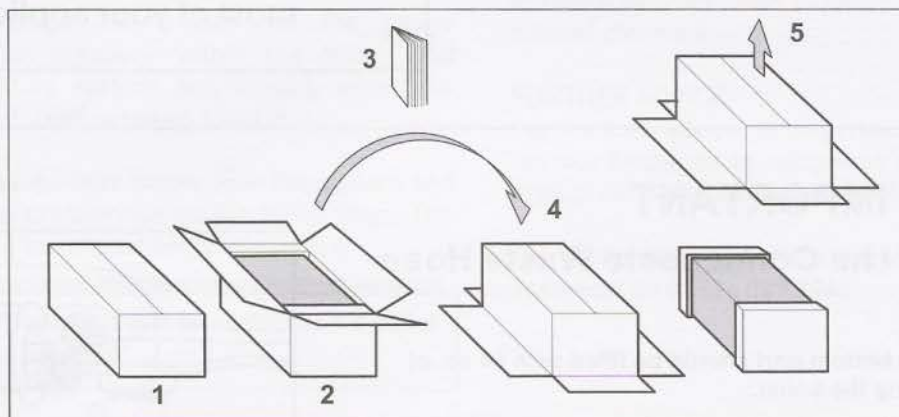

Handling

This appliance is heavy, truck if possible and obtain assistance if required.

To remove the appliance :

1. Carefully slit or remove the scaling tape being careful not to scratch the appliance door.
2. fully open the carton lid and remove any instructions & components.
3. Read the instructions carefully before installation of the appliance.
4. Roll the carton onto its open face.
5. Lift the carton free of the inner packaging.
6. Remove the mounting bracket and valve package.
7. Stand the boiler on its base within the styrene block and remove the top packaging piece.
8. If you wish to remove the styrene base lie the appliance on its back to do so.

1. Installation Regulations

- 1.1. Correctly may invalidate your guarantee and may lead a dangerous situation.
- 1.2. Your CORGI registered engineer should carry a CORGI ID card containing their registration number, which should be recorded in your BENCHMARK Log Book, which is supplied with the Instructions. You can check the validity of this ID number by contacting CORGI on 0800 915 0480.
- 1.3. This appliance must be installed in accordance with the Gas Safety (Installation and Use) Regulations, current Building Regulations, Building Standards (Scotland), I.S.813 Installation of Gas Appliances (Ireland), IEE Wiring Regulations (BS 7671), Health and Safety Document No. 635 (Electricity at Work Regulations) and Local Water Authority Bye Laws.
- 1.4. On installation the following British Standards must also be considered:
 - ✓ BS 6798 Specification for installation of gas fired hot water boilers of rated input not exceeding 70kW.
 - ✓ BS 5449 Central heating for Domestic Premises.
 - ✓ BS 5546 Installation of gas hot water supplies for domestic purposes.
 - ✓ BS 5440 Flues and Ventilation for gas appliances of rated input not exceeding 70kW (Part 1 Flues)
 - ✓ BS 5440 Flues and Ventilation for gas appliances of rated input not exceeding 70kW (Part 2 Air Supply)
 - ✓ BS 6891 Installation of low pressure gas pipe-work installations up to 28mm (R1¼).Reference should also be made to British Gas Guidance Notes for Installation of Domestic Gas Fired Boilers.
- 1.5. Due to the manufacturer's continuous improvement policy the manufacturer reserves the right to change any specification of the appliance or make modifications to these instructions, which meet current regulations at the time of print. However, the instructions must not be taken as overriding statutory requirements.
- 1.6. To ensure reliability and continued performance ensure that other components in the system are also approved to relevant standards and that the appliance and system is adequately protected and maintained on an annual basis.

For further information or advice contact Hydroline™
Service & Technical Enquiries in the UK:

Service: 08444 810 218

Sales: 01234 334 667

Technical: 01234 329 106

Or by E mail on the website: www.hydroline.co.uk

2. Technical Data

		Hydroline B 24
Heat Input (max)	kW	25.7
Heat Output (max)	kW	24.7
Heat Input (min)	kW	11
Heat Output (min)	kW	10.2
Useful efficiency at 100% load	%	96
Useful efficiency at 30% load	%	102.4
Burner injector	mm.	1.20 NG 0.75 LPG
Burner Pressure (Natural Gas)	mbar	Max 12.5 Min 2.5
Burner Pressure (Propane)	mbar	Max 28.5 / 36.5 Min 6 / 7.8
Power Supply	Input	220-240V-50Hz
Max. power consumption	Watt	220
Level of Protection		IPX 4 D
Case Dimensions	mm	330d x 405w x 720h

		Hydroline B 24
Maximum heating temperature	°C	85
Max. domestic hot water temperature	°C	64
Operating pressure (Bar)	PMS Nominal (Min)	3 1.5 (0.8)
Domestic water supply pressure (Bar)	PMS (Min)	8 (0.25)
Expansion Vessel Capacity	Litres	7
Expansion Vessel Pre-charge Pressure	bar	1
Domestic Water Supply Output at 30° C Δ T	Lt/min	11
Air Intake Pipe Diameter	mm	100/125
Flue Pipe Diameter	mm	60/80
Max. Flue Length C12 – C32	m	3.0 (60/100) 7.0 (80/125)
Max. Flue Length C42 – C52	m	20 (80/80)
Equivalent Length 45° Bend	m	1.0
Equivalent Length 90° Bend	m	1.5
Net weight	kg	37
Gross Weight	kg	40

Figure 1

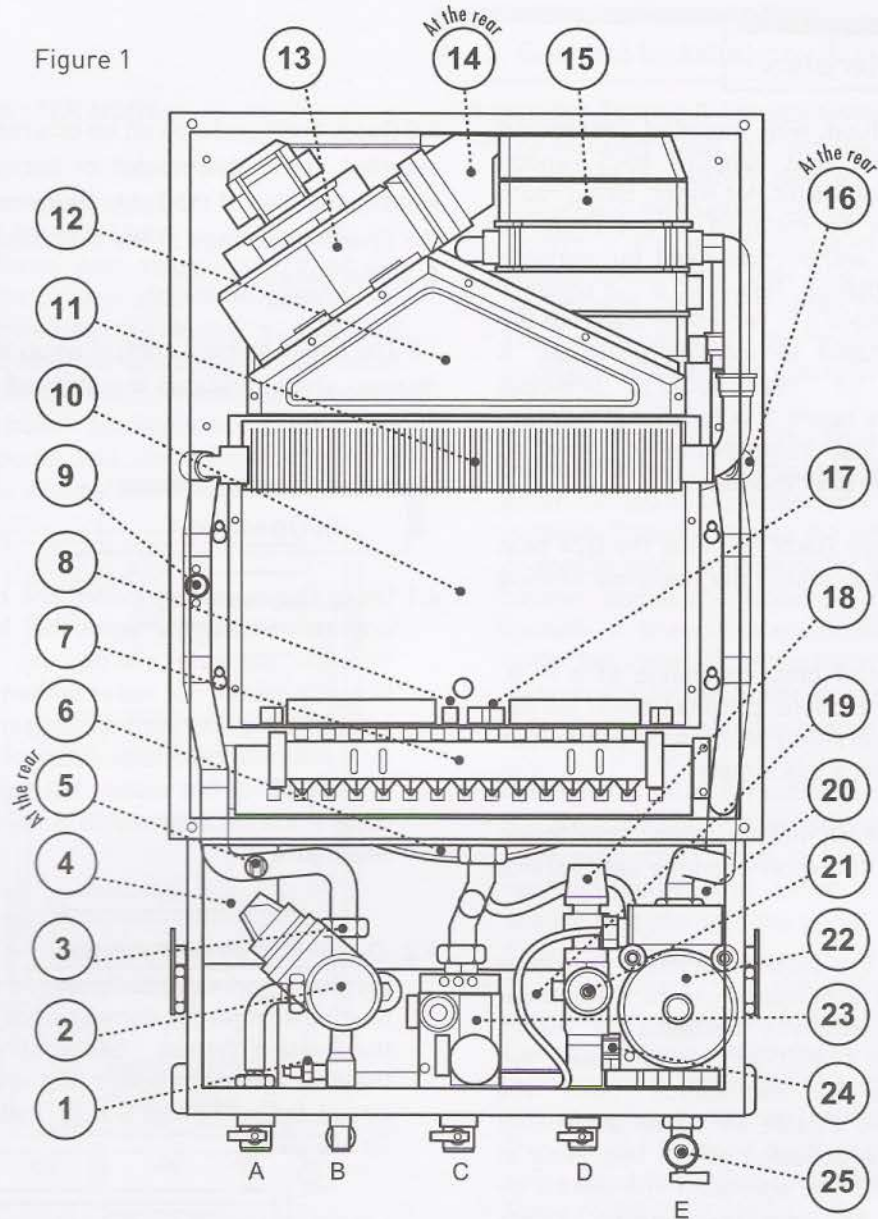

- | | |
|-----------------------------|--------|
| A - Heating Flow | (22mm) |
| B - D.H.W. Outlet | (15mm) |
| C - Gas Inlet | (22mm) |
| D - Cold Water Inlet | (15mm) |
| E - Heating Return | (22mm) |

Key

- | | |
|--|---|
| 1 - D.H.W. Sensor | 14 - Air Pressure Switch |
| 2 - Diverter Valve Motor | 15 - Condensing Unit (Turbo heat exchanger) |
| 3 - Diverter Valve | 16 - Overheat thermostat |
| 4 - Condensate Trap | 17 - Ignition Electrode |
| 5 - Overheat Safety Thermostat | 18 - Heating Circuit- Pressure Safety Valve |
| 6 - Expansion Vessel (At rear of the boiler) | 19 - Secondary Heat Exchanger |
| 7 - Burner | 20 - Automatic Air Vent |
| 8 - Flame Sensor Electrode | 21 - Water Pressure Switch/Sensor |
| 9 - C.H. Sensor (Heating Sensor) | 22 - Pump |
| 10 - Combustion Chamber | 23 - Gas Valve |
| 11 - Primary Heat Exchanger | 24 - D.H.W. Flow Sensor |
| 12 - Fan Hood | 25 - Filter Valve (Below the pump) |
| 13 - Fan | |

3. Boiler Characteristics

3.1 The B24 is a fan flued, wall-mounted condensing type combination boiler that supplies both central heating and mains fed domestic hot water. Being room sealed the boiler may be installed in any room or internal compartment without the need for purpose made combustion ventilation. However, if the boiler is installed in a compartment it is recommended that the compartment is ventilated for cooling purposes. A functional diagram of the boiler's principal components is given as figure 1. A functional diagram of the boiler's principal components is given as *VENTILATION section in user manual*

3.2 Range rated between 20kW and 9kW the B24 heat output can be adjusted to match the designed heating systems requirements.

3.3 An electronic control unit, consisting of a PCB, which includes ignition module, provides direct burner ignition and flame supervision along with continuous modulation of the burner's gas supply.

3.4 An interface unit, which includes boiler adjustment potentiometers and fault display provides easy service ability to the boiler.

3.5 Heat transfer to the boiler's primary hydraulic circuit is obtained via a primary, gas to water heat exchanger contained within a hermetically sealed combustion chamber. A 230 volt, dual speed fan expels the products of combustion from the combustion chamber to outside air via an associated flue system. The fan is activated at the beginning of each ignition cycle and its operation monitored by means of negative and positive sensing points connected to an air pressure switch.

3.6 A secondary heat exchanger allows the instantaneous transferral of heat from the primary hydraulic circuit to water destined for domestic hot water use. The secondary heat exchanger is sized so as to minimise thermal shock and is protected against the build up of lime scale by limiting the D.H.W. outlet water temperature to a maximum of 64°C.

3.7 An integral pump located in the boiler's main hydraulic circuit circulates water through the primary heat exchanger to either the central heating circuit or D.H.W. heat exchanger, depending on the demand. In the event of reduced or interrupted water circulation in the central heating circuit, a system by-pass should be fitted as far away from the boiler as possible.

Note: It is no longer permissible to utilise a non-thermostatic controlled radiator as a by-pass.

3.8 Room temperature can be controlled by the use of an external room thermostat or temperature regulator. Note connection of the room thermostat is dependant on the operating voltage of the thermostat. See section 9.4 & 9.5 for details

3.9 The boiler's control panel incorporates an LED display, which indicates the state of operation and fault defect codes.

4. Operation

4.1 Using the operating switch the boiler can be set to operate either on domestic hot water only or domestic hot water and heating.

Note: Domestic hot water demand draws preference over heating. During heating periods the boiler will automatically revert back to heating mode, after a draw off of hot water, but there will be a 45sec delay if the No.3 dipswitch is set to the OFF position. See figure 21.

4.2 Depending on demand water is either diverted via the three port valve to the secondary water-to-water heat exchanger for domestic hot water or directly to the heating system. Schematic diagrams showing the flow within the boiler's central heating hydraulic circuit figure 2a and D.H.W. hydraulic circuit figure 2b are given.

Figure 2a

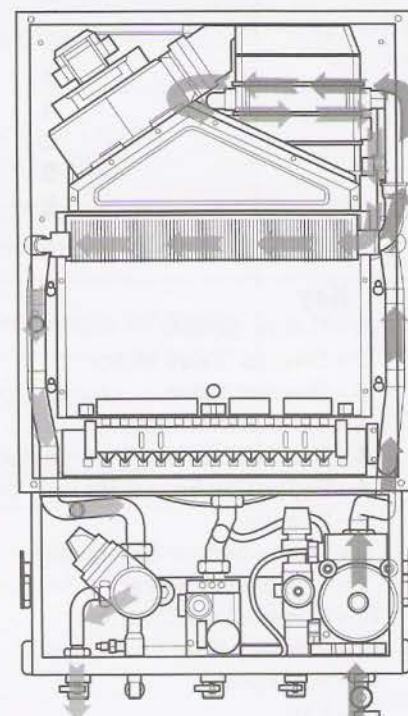

CENTRAL HEATING HYDRAULIC CIRCUIT

5. General Installation

4.3 DOMESTIC HOT WATER MODE:

On opening a hot water outlet the boiler automatically responds to fire the boiler and supply the water-to-water heat exchanger with hot water via the three port valve, located on the hydro-block. The boiler's electronic control unit automatically modulate the burner's output to maintain the required temperature at the faucet. Hot water will continue to flow until the faucet is closed and the boiler automatically shuts down. Note that the pump will continue to run for a further 10secs to dissipate the residual heat from the boiler.

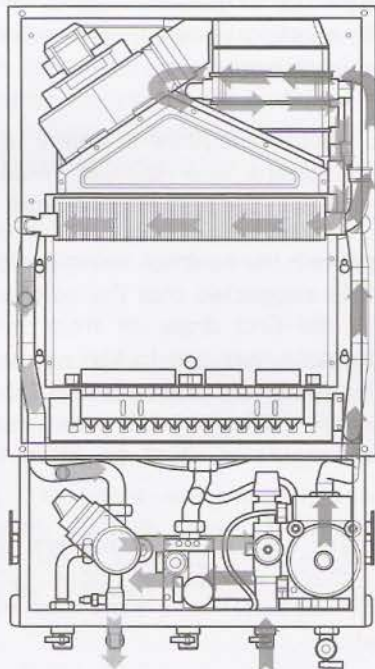

Figure 2b

DOMESTIC HOT WATER HYDRAULIC CIRCUIT

4.4 DOMESTIC HOT WATER AND CENTRAL HEATING MODE:

When heating demand is requested, power is on and the thermostats are calling for heat, the boiler will fire automatically. An integral pump is then energised and hot water from the boiler's primary circuit is circulated around the central heating systems pipe-work and radiators. When the demand for central heating is no longer present, e.g. the thermostat reaches temperature, the burner will shut down and the boiler will revert to stand-by, waiting to respond to the next heating or hot water demand. The pump will continue to operate for a short period of time to dissipate any excess heat from within the boiler's heat-exchanger. If during the heating period there is a call for hot water this will take preference over heating. When satisfied the boiler will then supply the heating demand as required. Note there may be a 45sec delay depending on how the boiler's dipswitches are set. See section 15.4 for details.

5.1 Installer Testing & Commissioning Tips

- The installer shall instruct the user in the operation of the boiler, safety devices contained within the boiler and instruction on how to re-pressurise the system if the water pressure falls. The installer should then hand over the instructions with the Benchmark Logbook that has been completed.
- The user should be instructed to keep the instructions in a safe place for servicing and future reference.
- It is important to keep the boiler clear of dust during the installation. In particular, do not allow debris to enter the top of the boiler where the flue connection is made. This may cause the fan outlet to get blocked or combustion chamber to fill with debris and will, of course, cause the boiler to fail to ignite on first ignition. It is recommended that you check the fan outlet before you light the boiler.
- Before you fit the boiler ensure that the pipe work that you are installing is connected to the appropriate connections on the boiler i.e. cold water pipe to cold water inlet, hot water outlet to the hot water tap etc.
- Because the boiler is actually operated, at the end of each production stage, a small amount of water is retained within the boiler when packed. Please ensure that you spin the pump rotor manually before firing the boiler.
- It is important that the boiler must be used in conjunction with a Hydroline approved flue and all flue connections are correctly sealed.
- Remember to flush out the system, both cold and hot, in order to remove the debris from the system. This should be done particularly where boilers are being fitted to existing radiator circuits.
- Refer to BS 7593:1992 for the details to clean DHW and Central heating systems.
- This boiler's central heating output has been set to a mid range position. However you may choose to adjust this using potentiometer P2 to meet the requirement of the system.
- Remember to release the small cap on top of the auto air purge device on the pump, 1 turn, before filling. This will ensure that air is removed as the system fills.
- Do not use the pressure relief valve as a means of flushing the system, please use the valve below the pump. Discharging water from the pressure relief valve may allow water to seep after you have left the job, causing the boiler to lose pressure and debris to collect on the seating.
- The boiler is fitted with inlet filters both on the cold water inlet and the central heating return. If you are unable to obtain hot water at an outlet
- it is likely that the cold water inlet valve filter has become blocked, whilst blockage of the filter on central heating return valve, the overheat thermostat

will cause the heater to lock out at as the water flow is reduced.

- If you are able to obtain hot water but not heating it is also advisable to check that the room thermostat and any external time clock that may be fitted are calling for heat.
- Remember that after hot water draw off there is a 45 sec delay before the heating will fire up if No.3 dipswitch is in the OFF position, see figure 21
- When commissioning the boiler check the inlet pressure is at 20mbar and burner pressure against the Technical data, section 2.
- Note an anti-cycle delay time can be set up to a maximum of 255 seconds by adjusting potentiometer 2 as described in section 15.5
- If you experience any problems please refer to the installation and commissioning guidelines within the boiler instruction manual. If necessary, please contact Hydroline™ Service Enquiries, in the UK, for further advice and assistance on
Sales – 01234 334 667
Service – 08444 810 218
Technical – 01234 329 106

NOTE – FOR INSTALLERS:

REMEMBER IT IS A REQUIREMENT TO COMPLETE THE BENCHMARK CODE OF PRACTICE LOGBOOK BEFORE LEAVING THE INSTALLATION.

5.2 The boiler is designed to operate on fully pumped, pressurised sealed systems operating at a maximum of 3bar pressure and maximum design flow temperature of 85°C.

5.3 The boiler's integral expansion vessel is pre-charged to a pressure of 0.5bar and will accommodate a system volume of 125 litres. at an average water temperature of 75°C and maximum system pressure of 3 bar. If the system volume is more than 125 litres. an additional expansion vessel must be fitted to suit the size of the system. A typical installation of an additional pressure vessel is shown in figure 3

5.4 The heating circuit should be designed and balanced to give a 20°C temperature rise across the boiler flow and return.

5.5 When fitting a new boiler to an existing system the system must be thoroughly flushed in accordance with the recommendations of BS7593 prior to installation.

5.6 It is recommended that the system should be protected by an anticorrosion inhibitor. Failure to comply with this requirement may invalidate your guarantee.

5.7 On installation it is important to ensure that the heat exchanger is not a natural collecting point for air and where possible, the system pipe work should have a gradient to ensure any excess air is carried naturally to other purpose made, air release points.

5.8 In high water volume systems or under floor heating systems where prolonged operation of the boiler is expected at temperatures below 60°C, a by-pass must be installed on the boiler outlet in order to prevent condensation forming inside the combustion chamber. Failure to comply with this requirement will invalidate the manufacturer's guarantee.

5.9 The pressure relief discharge must be directed away from any electrical equipment or where it could cause a hazardous situation.

5.10 To enable adequate drainage of the system drain cocks compliant with BS2879 must be fitted at the lowest points in the system pipe-work.

5.11 To obtain the best hot water performance from your boiler it is suggested that the cold water supply to the boiler is the first draw off from the incoming mains supply. Note that the boiler will not operate unless there is a minimum pressure of 0.25bar with a flow rate of 2.5l/min. Where inlet pressures exceed 8bar, a pressure regulator must be fitted to the cold water supply.

5.12 Where cold water mains are fitted with a water meter, check valve(s) or loose jumper stopcock, a domestic hot water mini-expansion vessel may need to be fitted.

5.13 Although the boiler is designed to inhibit the formation of scale, in hard water areas above 200mg/l, a proprietary scale reduced should be fitted in the cold water supply to the boiler. Failure to comply may invalidate your guarantee. The local water undertaking will advise on water hardness.

5.14 To obtain the best hot water performance from your boiler it is suggested that supplies to outlets are run in 15mm copper, as short as possible and where practical, be insulated to reduce heat loss.

5.15 The boiler incorporates a frost protection thermostat. Therefore if the boiler will not be used for long periods of time during cold weather, in order to avoid freezing the electric supply must be left ON and all the central heating isolation valves must be left open. The internal frost thermostat will then operate the boiler if the temperature falls too low. However, if the electrical supply is to be turned off the boiler, the heating system and domestic hot water circuit must be drained.

5.16 The boiler incorporates a frost protection thermostat. Therefore if the boiler will not be used for long periods of time during cold weather, in order to avoid freezing the electric supply must be left ON and all the central heating isolation valves must be left open. The internal frost thermostat will then operate the boiler if the temperature falls too low. However, if the electrical supply is to be turned off the boiler, the heating system and domestic hot water circuit must be drained.

6. Appliance Siting

6.1 If the boiler is to be installed in any room or compartment, it requires no purpose made ventilation for combustion air. If sited in a room containing a bath or shower then particular reference is drawn to the requirements of British Standard 7267 (confirm) [I.E.E. Wiring Regulations] and Building Regulations.

6.2 If the B24 boiler is installed in a compartment there must be purpose made ventilation for cooling purposes.

6.3 The boiler is not suitable for external installation unless protected by a purpose made building such as a boiler house.

6.4 The following clearances are recommended for installation purposes; 200mm above, 300mm below and 50mm at each side. 600mm is required at the front but this may be provided by opening a cupboard door.

6.5 The boiler must be sited at least 1m away from flammable materials and heat sensitive walls must be protected by an appropriate insulating material.

6.6 The wall on which the boiler is mounted must be sufficiently strong enough to support the weight of the boiler.

6.7 A condensate drain pipe must be fitted to allow discharge of condensate to a drain or soak way. Where possible condensate should be discharged into the household internal drainage system. If this is not practical, discharge can be made into an external drain. If neither of the above options are possible then condensate must be discharged into a purpose designed soak way.

It is recommended that any external condensate pipe is insulated and increased to 32mm diameter in order to prevent the condensate from freezing.

To avoid excessive condensation occurring within the boiler flue the boiler should wherever possible, be sited to ensure the shortest possible flue run is utilised.

6.8 For compartment installation the requirements of BS6798 and BS5440: Part 2 must be met.

- The compartment must be of sufficient size to permit access for inspection and servicing or the removal of the boiler and any ancillary equipment.
- Any space used for airing clothes or storage must be separated from the appliance by a non-combustible partition. Where the partition is formed from perforated material, then the major dimension of the apertures shall not exceed 13mm.
- No combustible surface must be within 20mm of the boiler casing without protection.
- There must be 20 mm clearance between the compartment door and boiler case.
- Where the boiler's flue pipe passes through the airing space, it must be protected by a non-combustible sleeve or fire stop which has a minimum clearance of 25 mm from the flue pipe. In addition, if the flue pipe passes through the partition then the clearance gap of the flue pipe or its guard with the partition must not exceed 13 mm.

6.9 When the boiler is intended for use with LPG it must not be installed in a room or internal space below ground level.

7. Flue Terminal Location

7.1 The flue terminal must be sited with minimum clearances as specified in *Figure 4*. Note if plumbing becomes problematic or causes a nuisance a plume management kit is available from your stockist.

7.2 Current regulations and standards require a terminal guard to be fitted where the terminal is accessible to touch or at risk of being damaged. All wall mounted terminals sited within 2m of the level which people have normal access, should be adequately protected with a suitably sited guard.

7.3 Where the flue terminates within 1m of a plastic or painted gutter or within 500mm of painted eaves then protection should be provided in the form of an aluminium shield at least 1m in length, fitted to the underside of the gutter or painted surface.

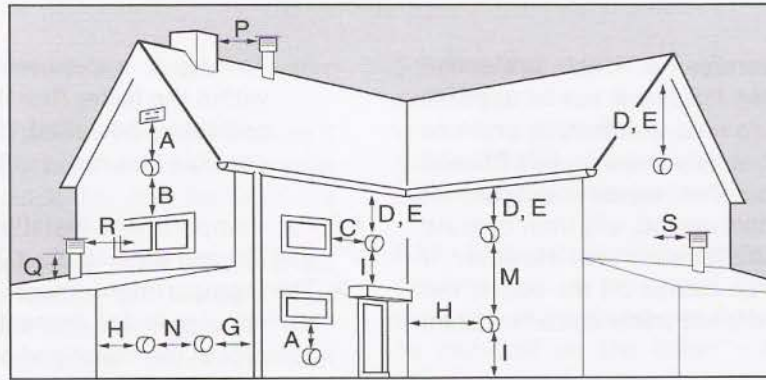

UNDER CAR PORT etc.

Figure 4

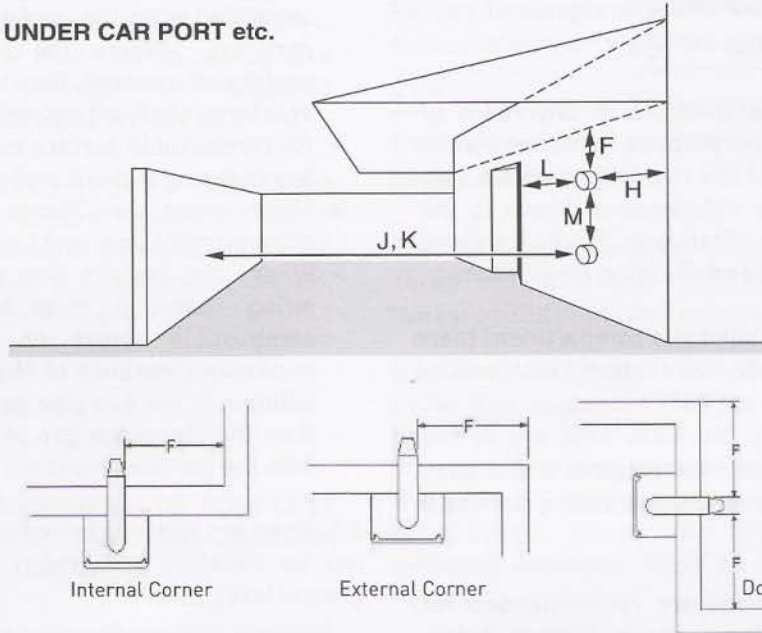

Location	Description (See diagram)	Clearance (mm)
A	Below an opening (See Note 1)	300
B	Above an opening	300
C	Horizontally to an opening	300
D	Below gutters, soil pipes or drain pipes	75
E	Below eaves	200
F	Below balcony or car port roof	200
G	From a vertical drain pipe or soil pipe	150
H	From an internal or external corner or to a boundary alongside the terminal (See Note 2)	300
I	Above ground, roof or balcony level	300
J	From a surface or a boundary facing the terminal (See Note 2)	600
K	From a terminal facing the terminal	1200
L	From an opening in the car port into the building	1200
M	Vertically from a terminal on the same wall	1500
N	Horizontally from a terminal on the same wall	300
P	From a structure on the roof or another roof terminal	600
Q	From a vertical flue terminal to an adjacent wall	300
R	From a vertical flue terminal to an adjacent wall which includes an opening window (See Note 3)	1000
Notes:	<ol style="list-style-type: none"> 1. An opening here means an opening element, such as an openable window, or a fixed opening such as a air vent. However, in addition, the outlet should not be nearer than 150mm to an opening into the building fabric formed for the purpose of accommodating a built in element, such as a window frame. 2. Boundary as defined in the Building Regulations (England & Wales) or the Building Standards (Scotland) Regulations. 3. Where the wall adjacent to a vertical flue terminal includes an opening window, the clearance between the terminal and any part of the opening window must not be less than 1000 mm. 	

7.4 The flue should not be sited where the condensate plume may give rise to a nuisance factor under certain weather conditions.

NOTE: If you have difficulty siting the flue in an appropriate location your supplier will be happy to supply an "anti-plume management kit", which discharges the flue products at a higher level.

8. General Flue Info

8.1 The boiler utilises a concentric flue arrangement which consists of a 60mm-diameter inner flue and 100mm-diameter outer air inlet duct.

8.2. Various types of flues can be purchased with the boiler but the standard 700+/-5mm flue kit (figure 5) is supplied with the boiler, which can be routed to the rear, left or right of the appliance by means of a 90° bend. The bend is connected to the boiler using the screws provided and sealed with the gasket.

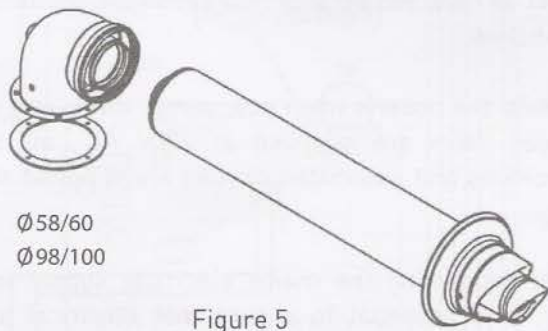

Figure 5

8.3. The 60/100 mm flue pipes may be extended up to a maximum of 2.5 m using additional spare components available from your supplier. This length can be increased to 7 m using the 80/125 mm flue kit.

8.4. A vertical 60/100 mm flue kit is also available from your supplier up to a maximum length of 3m. The terminal is suitable for a flat or pitched roof. This length can be increased to 7 m using the 80/125mm flue kit.

8.5. If horizontal and vertical flue lengths are less than 1 m, the restrictor (air diaphragm) – figure 6 must be fitted on the combination boiler.

Please find the information sheet for the installation of restrictor given with documentation group. The diameter of air diaphragm changes according to the installation types.

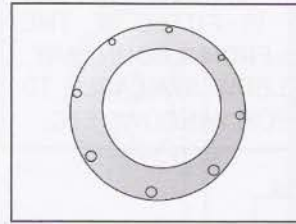

Figure 6

	C12-C32		C42-C52
	60/100	80/125	80/80
24 kW	Ø80	Ø80	Ø80

8.6 The air diaphragm should be removed if the length of the flue pipe installation is below:

	C12-C32		C42-C52
	60/100	80/125	80/80
24 kW	>1 m		>2 m

8.7. The connection of vertical flue system is similar to the Horizontal flue connection. The flue is connected to the boiler via connection screws whilst the sections are held together with the clamps provided.

8.8. To avoid condensate dripping from the terminal the flue should be installed with an upward gradient (from the boiler) of 3°. Note that some new flue may have the 3° built in.

8.9. The installation types for room sealed versions are C12-C32-C42-C52

8.10. The boiler can be used with separate ducts such as 80/80 to fit required type of installations.

Note. For each additional 90° elbow used the maximum flue length must be reduced by 1.5 m, whilst the use of 2 x 45° bends warrants a reduction of 2m.

WARNING!

ONLY AN APPROVED FLUE IS TO BE USED WITH THIS PRODUCT. FAILURE TO COMPLY WITH THIS REQUIREMENT WILL INVALIDATE YOUR GUARANTEE AND COULD LEAD TO A DANGEROUS SITUATION.

FOR CONDENSING BOILERS IT IS RECOMMENDED THAT AN ANTI PLUME KIT IS FITTED IF THE TERMINAL IS LESS THAN 2.5 m FROM A BOUNDARY. IN ADDITION THERE IS 45° ELBOW AVAILABLE TO DEFLECT THE PLUME AWAY FROM WINDOWS ETC.

9. Electrical Connections

9.1 The boiler is supplied factory wired complete with 1.5 m of mains fly lead. All electrical connections to the mains supply must be made in full accordance with the current I.E.E. regulations.

9.2 The boiler must be connected to an effective earth system. Using the cable supplied the boiler may be connected via a 3 amp fused three pin plug to an unswitched shuttered socket outlet. However if the boiler is installed in a room containing a bath or shower regulations dictate that disconnection must be incorporated in the fixed wiring with a switch provided for disconnection from the mains supply having a contact separation of at least 3 mm on all poles and fused at 3 amp.

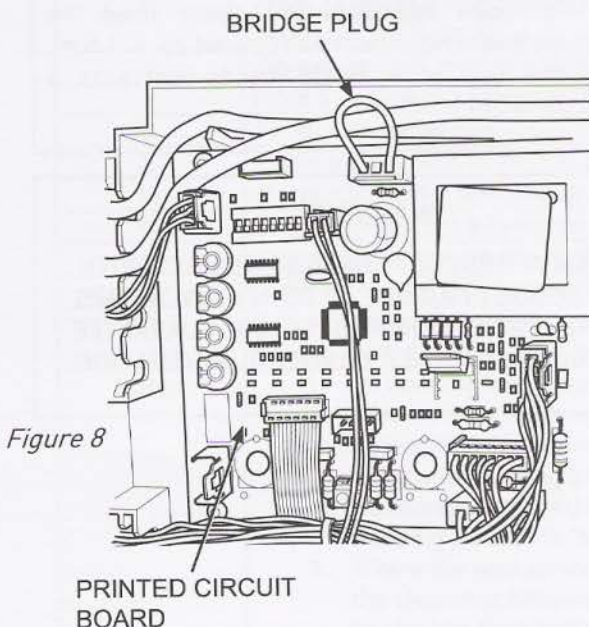
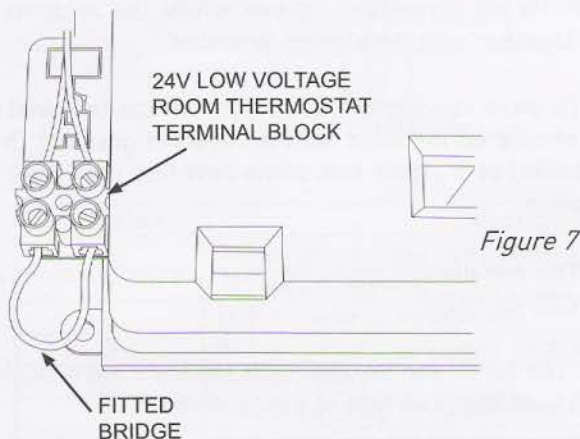

9.3 Other than for a bathroom installation the point of connection must be readily accessible, at a distance no further than 1.5m adjacent to the appliance and provide complete electrical isolation for the boiler and control system.

Warning: On no account must any external voltage be applied to any of the terminals on the heating control connection plug. Figure 7

located to behind of left side of the plastic cover (figure 7). On connection of a voltage free room thermostat to the boiler, the factory fitted bridge across the room thermostat terminal connectors must be removed. If a mains voltage thermostat is to be used please refer to figure 8.

9.5 Mains powered thermostats must be connected directly to the mains circuit board as indicated in Figure 8. Cut the existing link and connect the wires into the thermostat circuit.

9.6 Ensure that the polarity of the mains connection is correct as reversed polarity may cause the appliance to malfunction.

9.7 While the boiler's main pcb, pump, three-way valve and gas valve are supplied at 230V AC., all other components and associated circuits are supplied at low voltage.

9.8 On connecting the mains electrical supply to the boiler, it is essential to ensure that electrical safety checks for earth continuity, earth resistance, polarity and short circuit are carried out prior to making the final connection. A diagram of the boiler's electrical circuit is given as figure 9.

9.9 Fuse Ratings

Circuit Board
F1 - 2amp fast blow
F2 - 2amp fast blow

Important Note

Connection to the mains electrical supply must be maintained at all times in order to provide domestic hot water, frost protection and pump over-run facility. Ensure that the boilers electrical supply is not interrupted by any external controls.

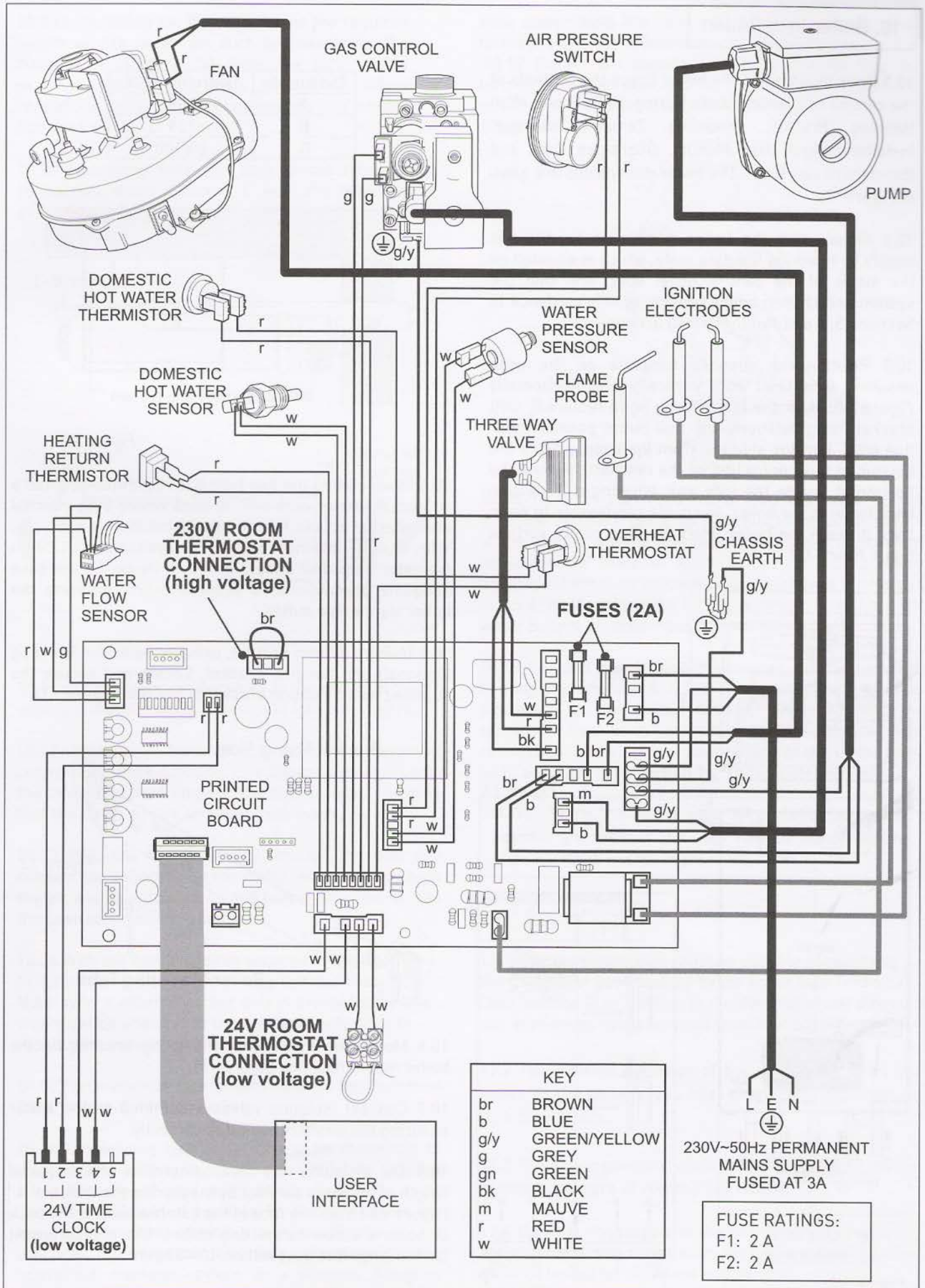

KEY	
br	BROWN
b	BLUE
g/y	GREEN/YELLOW
g	GREY
gn	GREEN
bk	BLACK
m	MAUVE
r	RED
w	WHITE

230V~50Hz PERMANENT
MAINS SUPPLY
FUSED AT 3A

FUSE RATINGS:
F1: 2 A
F2: 2 A

Figure 9

10. Boiler Installation

10.1 Prior to installing the boiler check the contents of the carton: Appliance, Valves (Fixing Jig Optional), Wall Hanging Bracket, Mounting Template Service, Installation and User Manual, Guarantee Card and Benchmark Log Book. The boiler dimensions are given in Figure 10.

10.2 Ensure that the boiler is suitable for the gas supply by checking the data plate, which is situated on the inside of the control panel door, and that the system and chosen boiler position is in accordance to Sections 5, 6 and 7 of these instructions.

10.3 Position the supplied template on the wall, ensuring it is level both vertically and horizontally (*figure 11*). Mark the boiler fixing jig (if required), wall bracket fixing positions and flue outlet position (rear flue only). For flue side exit from the boiler - Mark the horizontal flue centre line on the rear wall. Extend the horizontal line to the side wall allowing a 3° decline back towards the boiler, to enable condensate to drain back through the boiler. Mark the flue centre vertical line. (*figure 12*)

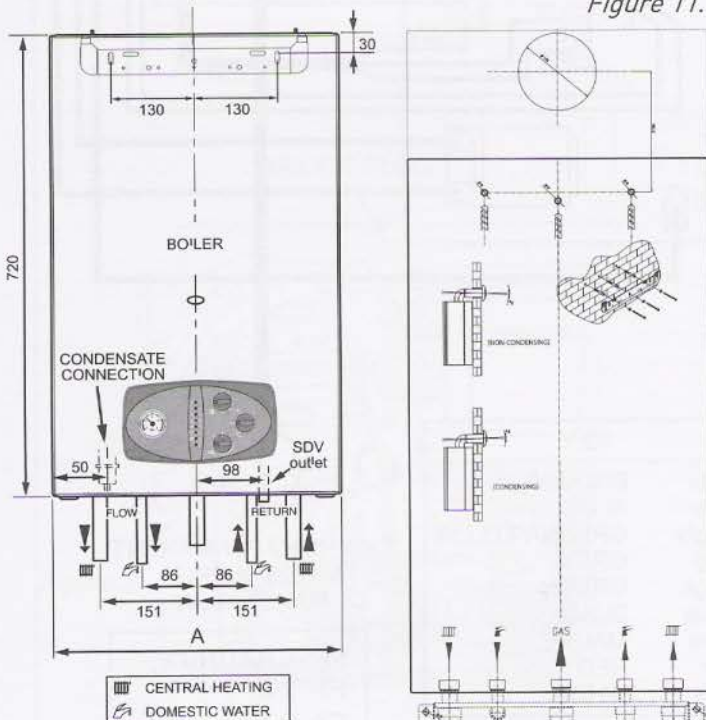
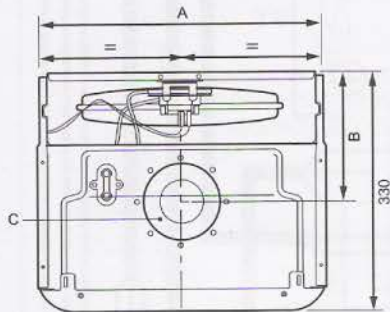

Figure 10.

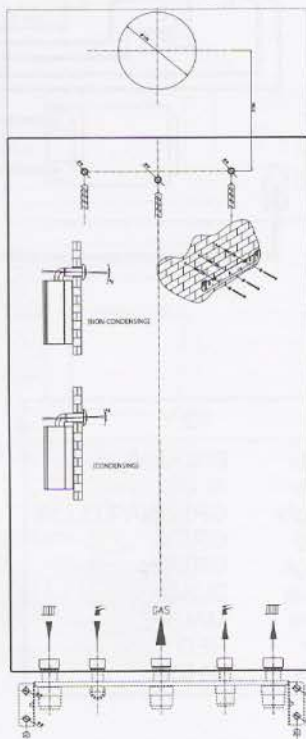

Figure 11.

Dimension	Hydroline B 24
A	405
B	169
C	60/100

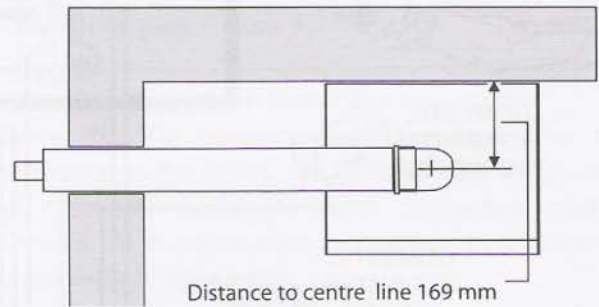
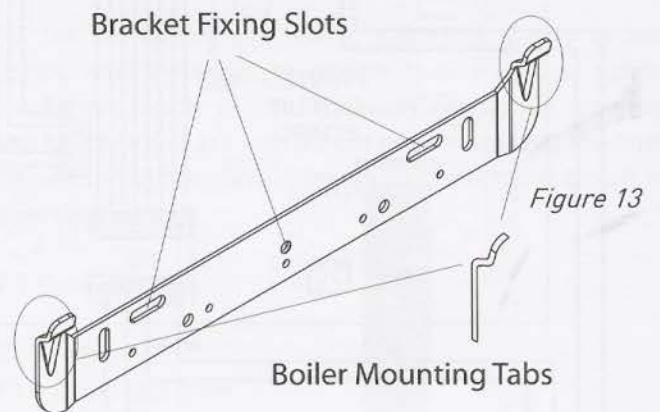

Figure 12

10.4 When cutting the flue hole it is recommended that a 105mm diameter core drill is used where both internal and external access for the flue installation is available. Where only internal access is available a 125mm diameter core drill should be used. (Note: Please take adequate precautions to prevent debris entering the boiler via the flue outlet).

10.5 Using a 8.5mm drill bit, drill the holes for fixing jig (optional) and hanging bracket. Locate and secure the supplied wall mounting bracket in position (*figure 13*).



10.6 Mount the boiler onto the fixing bracket via the boiler mounting slots, (*figure 13*).

10.7 Connect isolation valves assembled to the boiler ensuring the washers are fitted correctly.

10.8 On installing the flue, determine the required length of the outer air duct by measuring the distance 'L' (*figure 15*) from the face of the external wall to the back of boiler's elbow connecting collar. The measurement for the inner flue duct will be 'L' + 20mm

10.9 On installing the flue, determine the required length of the outer air duct by measuring the distance 'L' (Figure 14) from the face of the external wall to the back of boiler's elbow connecting collar. The measurement for the inner flue duct will be 'L' + 20mm

10.10 Measuring from the back of the terminal connection, mark distance 'L' onto the outer air duct. (figure 14)

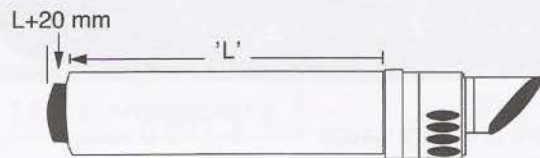

Figure 14

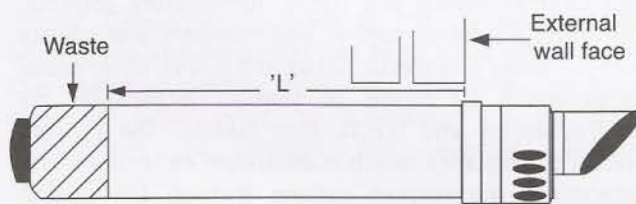

Figure 15

10.11 Cut the outer air duct only to the required length ensuring that the cut is square and free from burrs.

10.12 Measuring from the back of the terminal connection, mark distance 'L' + 20mm (figure 14) onto the inner flue duct and cut the duct to size, ensuring that the cut is square and free from burrs.

10.13 Pass the flue assembly through the wall and connect the assembly to the boiler, ensuring that both the air and flue duct joints are fully pushed home into the connecting elbow's collar.

10.14 With the flue and joints secured fit the flue trim to the external wall surface using suitable mastic. Note. Where internal access only is available, the flue trim must be attached to the flue assembly prior to passing the assembly through the wall.

10.15 For maximum flue lengths refer to the Technical Data, section 2 in this manual

10.16 Condensing type boilers must be connected to the drainage system. A plastic drain must be fitted to allow discharge of condensate to a drain. Condensate should, if possible, be discharged into the internal household draining system. If this is not practical, discharge can be made externally into the household drainage system or a purpose designed

soak away. Note if a soak way is used the drain must terminate at least 500mm from the external wall.

10.17 Extract the bottom part of condensate trap, by turning anti-clockwise and fill it with approximately 50 cc water re-connecting it to the boiler. (Figure 16).

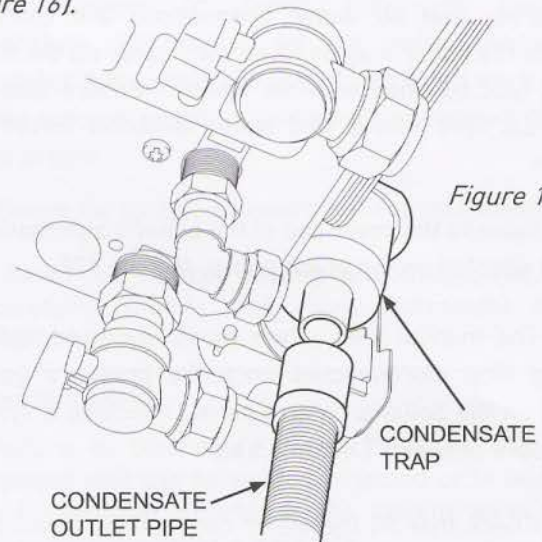

Figure 16

10.18 Connect the condensate drainage pipe to the drainage system. (Figure 16) Note due to the acidic nature of the condensate the drainage system must be made of non-corrosive material such as plastic tubing. More detailed information on condensate discharge is provided in BS 6798 (Specification for installation of gas fired hot water boilers of rated input not exceeding 70kW)

10.19 Connect the domestic hot water, cold water inlet, heating system flow & return and pressure relief valve pipework to the boiler fittings, ensuring that the pipework has been correctly flushed before final connection. The electrical connections to the boiler must be in accordance to Section 9 of these instructions.

NOTE: Place the filling loop in a visible accessible position and instruct the user how to pressurise the system if there is a fall in pressure.

11. Gas Supply

11.1 The gas supply pipe must be capable of supplying the quantity of gas required by the boiler (see Technical Data, section 2) in addition to the demand of any other gas appliances being serviced from that supply.

11.2 The internal diameter of the gas supply from the meter to the boiler's gas inlet connection must not be less than 22mm.

11.3 The meter governor must be capable of delivering a nominal pressure of 20mbar (for natural gas).

11.4 On final connection of the gas supply to the boiler, the complete gas installation including the gas meter, must be tested for tightness and purged.

12. Filling the System

12.1 The boiler must not be operated without water.

12.2 On completion of the boiler installation and ensuring that all water connections are correctly made the boiler may be filled with water via the filling loop (not supplied with the boiler). Ensure that two manual feed valves and boiler isolation valves are open.

12.3 Release the cover cap of the boiler's automatic air vent situated on top of the pump. (Figure 17)

12.4 The manual feed valves must be closed and the filling loop disconnected once the pressure gauge, sited on the boiler's control panel, indicates a system pressure between 1.0 and 1.5 bar.

12.5 Check that all the water connections throughout the system are sound and bleed each of the heating system's radiators in turn. As air is vented the system pressure may need topping back up to 1.0bar.

12.6 Air must be vented from the boiler's pump by unscrewing the pump's integral vent plug and allowing water to bleed for a few seconds. Take care not to allow water to splash onto any electrical components.

Release the cover cap
(behind the pump) when
the filling complete



Figure 17

12.7 When the system is bled of any air it must be re-filled until the pressure shown on the display gauge indicates a system pressure of 1.5bar.

12.8 If the pressure shown on the gauge exceeds 1.5 bar discharge the excess pressure from the system via a radiator valve or pipe connection. Do not use the safety discharge valve as the valve seat may become contaminated with debris and fail to re-seal.

13. Control Panel Functions

Figure 18

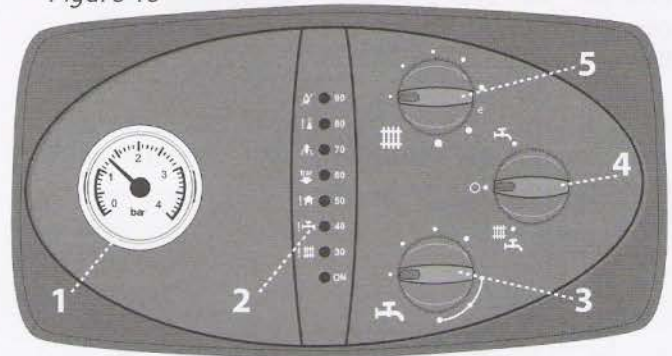

- 1- System pressure gauge 2- LED Display
3- D.H.W. temperature control 4- Function switch
5- C/heating temperature control

13.1 Central heating and D.H.W. temperature controls: The boiler's integral control unit monitors and adjusts both the boiler's hydraulic circuit and D.H.W. water outlet temperatures by means of sensors located on the Central/heating and D.H.W. flow outlets. The sensors electrical resistance, which is dependant on temperature, determines the current passing through the control potentiometers located on the control panel. The respective potentiometer control dial allows manual setting of the maximum required temperature (reference value) being between 30° and 85°C for C/heating and 35° and 64°C for D.H.W. When the boiler operates in heating or D.H.W. mode, the current received is compared to the manually set reference value. The difference of the two values operates the modulation of the gas valve adjusting the useful heat output generated and stabilising the temperature to within $\pm 1^\circ\text{C}$.

13.2 Re-set function: Should the boiler lock out at any time, please check the gas supply and ionisation probe position, the boiler may be re-started by switching to standby "0" position (Switch 4 figure 18) waiting 15-30 seconds and switching back to its previous position once the fault has been eliminated.

13.3 Function switch: The three position switch allows the boilers operation to be set to 'Stand-by' (centre position), 'Heating + D.H.W.' (left hand position) or 'D.H.W. only' (right hand position)

Flashing - Flames or Gas Failure		○ 90	Water Temperature
Flashing - Overheat Thermostat		○ 80	
Flashing - Fault on Air Pressure Switch		○ 70	
Flashing - Low System Pressure		○ 60	
Flashing - Fault on Outdoor Sensor		○ 50	
Flashing - Fault on DHW Sensor		○ 40	
Flashing - Fault on CH Sensor		○ 30	
		○ ON	Boiler Stand by Indicator

Important Note.

In order to maintain the appliance's warranty and so as to comply with the Domestic Heating Compliance Guide; when the boiler is to be installed to an existing central heating system, the system must be properly cleansed using a proprietary cleanser before the boiler is connected to the system. On all installations, after connecting the boiler to the system and initially filling with water, a proprietary inhibitor must be added to the system water to prevent corrosion.

14. Commissioning

14.1 The B24 boiler have been tested and pre-set at the factory and is dispatched with its on board controls set to provide a maximum central heating and D.H.W. output. Consequently, once all the connections have been made and the boiler has been filled with water to the designed system operating pressure, the boiler may be fired prior to adjusting it's on board parameters to match the heating systems requirements.

14.2 Prior to firing, check that the electrical supply to the boiler is 'On' (The green boiler 'Stand by' indicator will light) and the gas service cock is in the open position.

- Set the boiler's central heating and domestic hot water temperature controls to maximum by turning them fully clockwise.
- Set the external room thermostat (if fitted) to maximum and open the thermostatic radiator valves to maximum.

14.3 Switch the boilers function switch to the central heating and domestic hot water position. The boiler's control unit will now automatically carry out pre-ignition safety checks before igniting the burner.

14.4 During the 10 second burner ignition attempt visually check that all of the burner blades ignite correctly.

If necessary, adjustments to the ignition rate may be made using potentiometer P4. Turning P4 clockwise increases the ignition rate and anti-clockwise decreases the rate. After successful ignition check the integrity of the boiler's flue for tightness and correct operation.

14.5 Check the boiler for correct domestic hot water operation by opening and closing the household domestic hot water draw off taps.

14.6 In order to maintain the appliance warranty after initial filling the heating system must be thoroughly flushed using a propriety cleanser to remove foreign material and contaminants.

14.7 Restart the boiler and again allow the central heating system to reach maximum operating temperature. Check that all the water connections throughout the system are sound and bleed each of the heating systems radiators and purpose made air release points in turn.

14.8 Check the system pressure and top up if necessary.

14.9 Reset the central heating & domestic hot water temperature controls and room thermostat to the desired temperature settings.

Important Notice

- Failure to thoroughly power flush the heating system with the boiler disconnected or to add an anti corrosion inhibitor to the system water will invalidate the boiler's warranty.
- The condensate trap must be filled with water and plastic discharge pipe connected to drain before operating the boiler.

15. Onboard Adjustments

15.1 The boiler incorporates 4 potentiometers and a bank of dip switches to allow adjustment to its pre-set parameters. These are situated on the rear of the control panel.

The potentiometers can easily be accessed by removing the cover on the rear of control panel (*Figure 19*). However, to reach the dip switches, the control panel must be opened. (*Figure 20*).

15.2 Setting the maximum c/heating flow temperature: The boiler is dispatched with a maximum flow temperature factory set to 90°C. Where a lower maximum temperature is required such as in the case of under-floor heating, the factory setting can be altered between a maximum of 50°C and a minimum of 30°C, by fitting dip switch '6' into ON position.

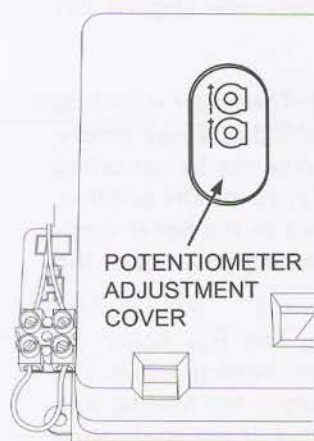

Figure 19

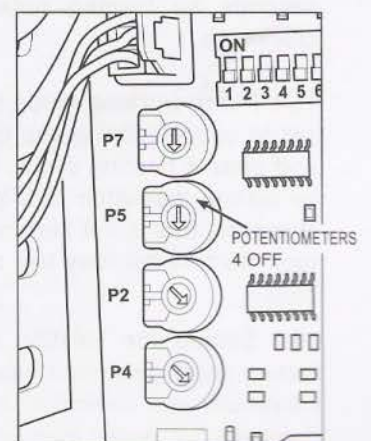

Figure 20

15.3 Setting the boiler's integral pump: The boiler's integral pump is factory set to operate in both central heating and D.H.W. mode. Where an external pump is incorporated into the system design the integral pump may be disconnected in central heating mode by fitting dip switch '5' into the ON position.

15.4 Setting the 45 seconds delay: The boiler is factory set to exclude the delay of 45 seconds before re-ignition between the closing of a hot water tap and CH start-up. This delay can be set to 45 seconds by setting dip switch '3' (Figure 22) into the OFF position.

Important
Gas Type Jumper, Dip Switch 1, Dip Switch 4 and Dip Switch 5 are factory set and must not be adjusted.

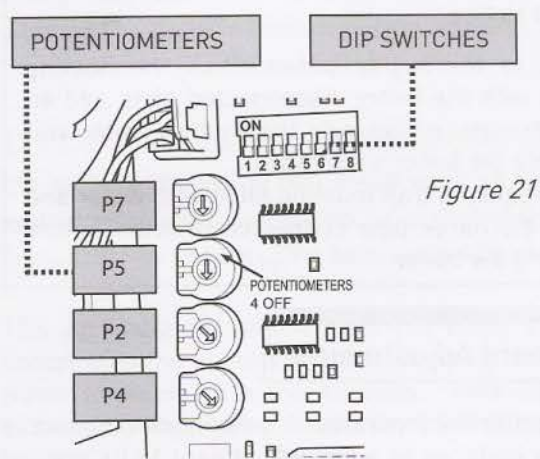

Figure 21

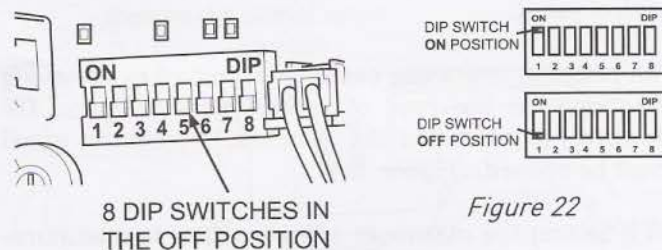

Figure 22

15.5 255 seconds delay setting: The boiler is capable of up to 255 seconds ignition delay (anti cycling time) before re-ignition following burner shut down on the primary hydraulic water reaching its set temperature. This delay can be increased up to a maximum of 255 seconds by turning potentiometer P5 (Figure 22) clockwise.

15.6 Pump working mode setting: The boiler is factory set to operate the pump for a period of 45sec before and after a heating cycle. This delay can be cancelled by setting dipswitch '2' (Figure 22) to the ON position. However, this is not recommended as the boiler over-heat thermostat may trip out, causing lock-out of the boiler.

15.7 Setting the Heating output: The B24 boiler is factory set to give mid range central heating output. The maximum and minimum heat output for heating and domestic hot water may be adjusted, if required, using potentiometers P2 (Figure 22).

15.8 Gas valve ignition capacity. The graduated opening of the gas valve for ignition rate is governed by potentiometer P4 control, which is factory set. To assist in setting the boiler's modulating gas rate parameters the ignition rate of the valve can be forced from minimum to maximum rate by setting the potentiometer clockwise.

15.9 The boiler's integral pump is factory set to its maximum speed setting to give a 1000 l/hr flow on a nominal over 5 m head. The pump may be adjusted to a lower speed to match the designed central heating system requirements. (Figure 23)

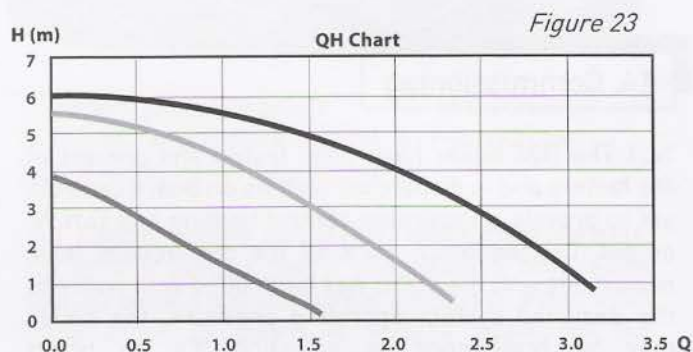

Figure 23

16. Safety Devices

16.1 A hydraulically operated primary pressure sensor monitors water pressure or water shortage in the primary hydraulic circuit and will switch the boiler off if the pressure is below 0.3bar. The boiler will not operate until the circuit has been re-pressurised.

16.2 The temperature of the water flowing from the primary heat exchanger is monitored by an overheat thermostat located on the outlet pipe. If the water temperature gets too hot the switch opens, cutting off the electrical supply to the gas valve and causing the boiler to 'Lock-out'. Once activated the boiler has to be manually re-set by switching the control knob off (for 15 seconds) and on again.

16.3 An air pressure switch situated in the boiler's fan compartment monitors the boiler's flue operation. If a partial obstruction within the flue occurs the fan will continue operating but the boiler's burner will shut down until the blockage is cleared.

16.4 The boiler's control unit has in-built frost protection device that fires the boiler's burner when the temperature of primary hydraulic water falls below 6°C. The device works irrespective of any room thermostat setting and will protect the complete heating system. On reaching a water temperature of 15°C the boiler reverts back to normal operation.

16.5 If there is a fault on DHW sensor, system continues operation by controlling DHW outlet temperature by flow sensor and CH sensor, which limits the temperature up to 65°C during DHW operation. If such failure occurs and displays on LED screen, please contact service department.

17. Fault Finding Chart

FAULT FINDING CHART 1

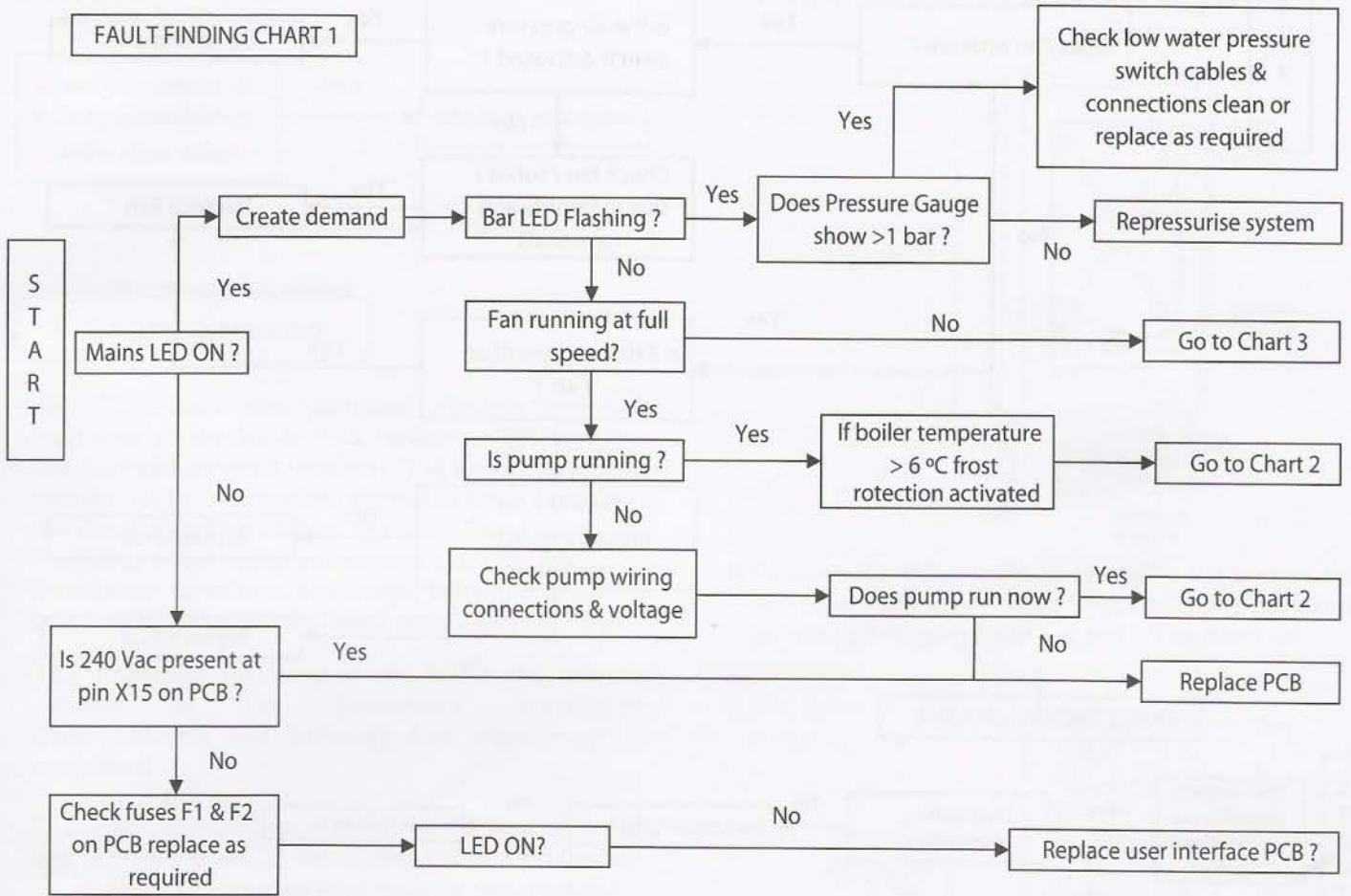

FAULT FINDING CHART 2

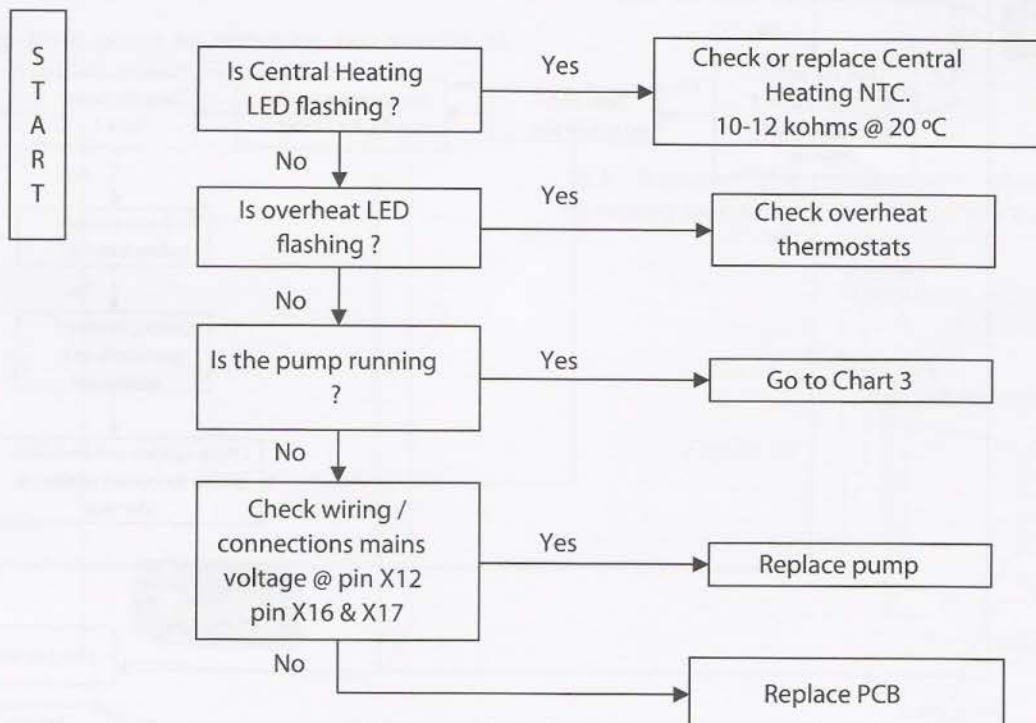

FAULT FINDING CHART 3

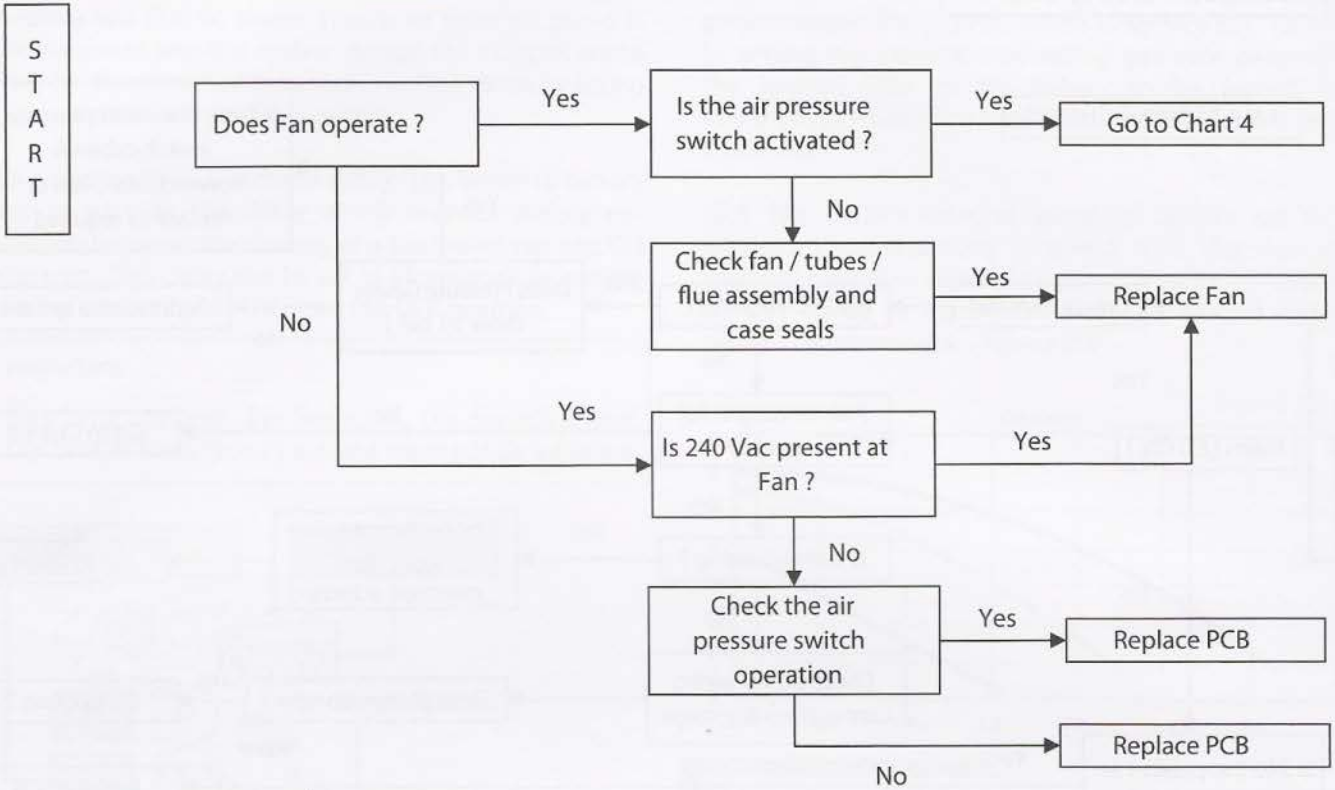

FAULT FINDING CHART 4

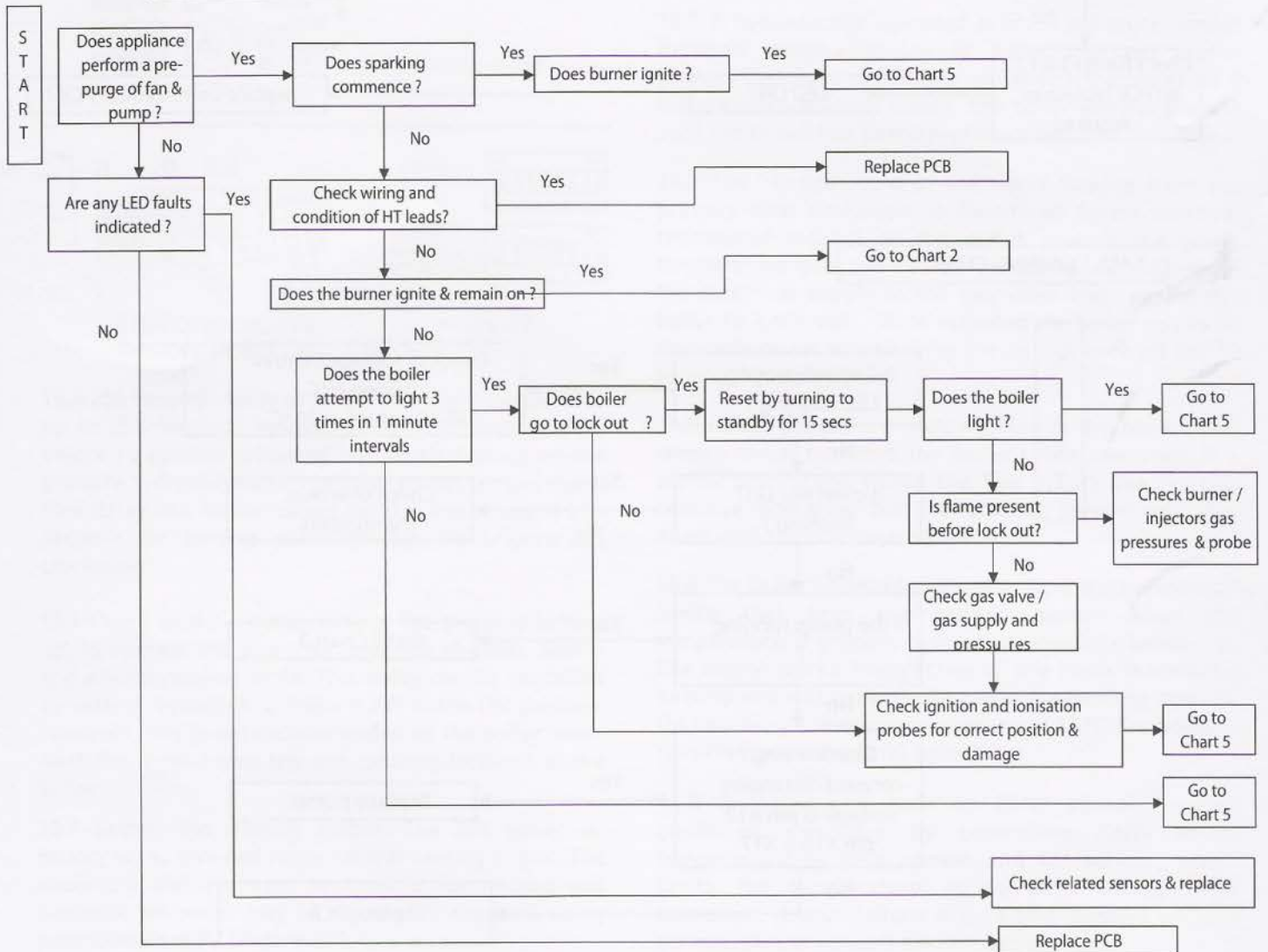

FAULT FINDING CHART 5

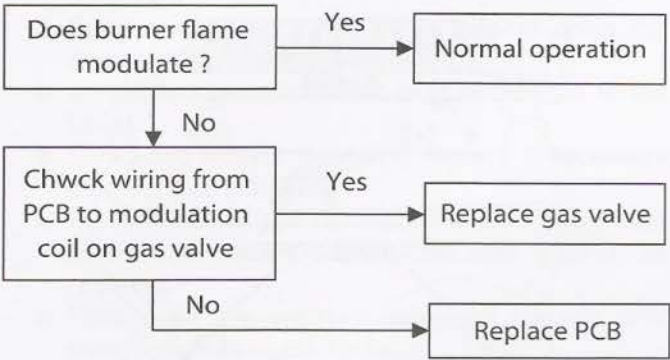

18. Routine Servicing

18.1 To ensure the continued efficient and safe operation of the boiler it is recommended that it is checked and serviced regularly. The servicing must be carried out by a competent person in accordance with the Gas Safety (Installation and Use) Regulations. The frequency of servicing will depend upon the particular installation conditions and usage, but in all cases the boiler must be serviced at least once a year.

18.2 Following servicing of the boiler the relevant sections of the 'Benchmark' Installation, Commissioning and Servicing Log Book must be completed.

18.3 Prior to servicing a check of the flue operation and terminal guard (if fitted) along with a preliminary check of the boilers operation must be undertaken.

18.4 Ensure the boiler is cold and that both the electrical and gas supplies to the boiler are isolated before commencing service of the boiler.

18.5 Remove the boiler casing as follows:

- Open the front panel by removing two screws at the bottom of the boiler, *Figure 25*.

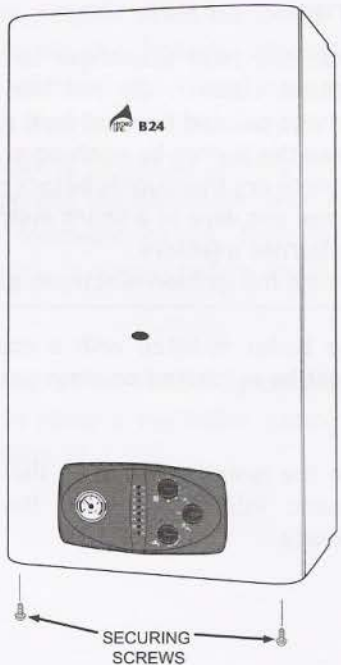

Figure 25

- Release the hermetic chamber cover by removing two screws on both sides and by lifting them to release from their retaining hooks. (*Figure 26*)

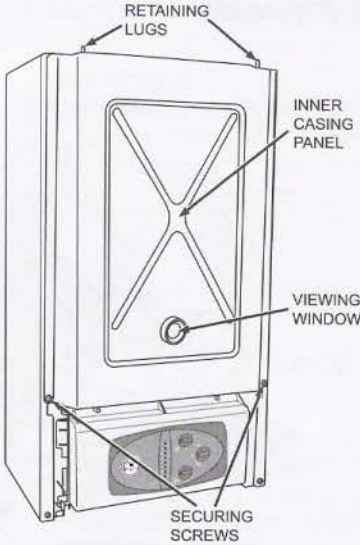

Figure 26

- Release the side panels by removing the screws on the upper and lower sides (*Figure 27*). Remove the panels by swinging them out and lifting them up.

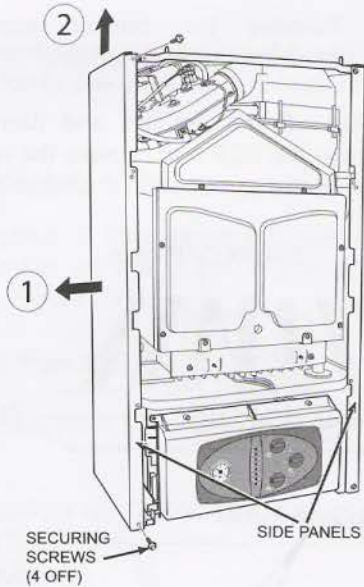

Figure 27

- 18.6 Remove the combustion chamber cover by removing four screws on sides. (*Figure 28*)

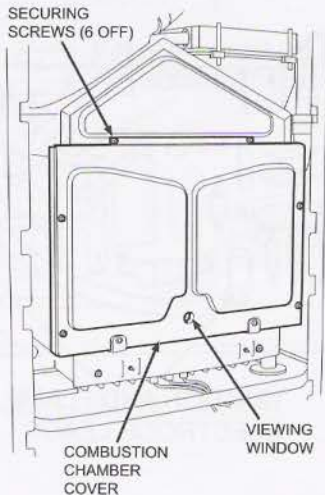
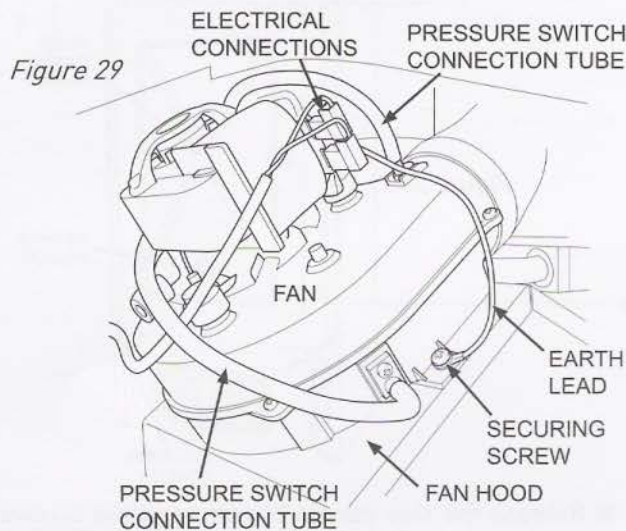

Figure 28

18.7 Disconnect the electrical leads and air pressure switch connection tube from the fan, remove the fan screws and withdraw fan from fan hood with its 56° bend. (Figure 29)



18.8 Remove the burner assembly from the combustion chamber as follows:

- Pull off the ignition and flame electrode leads from the PCB and remove the wires with grommet from the combustion chamber base. (Figure 30)

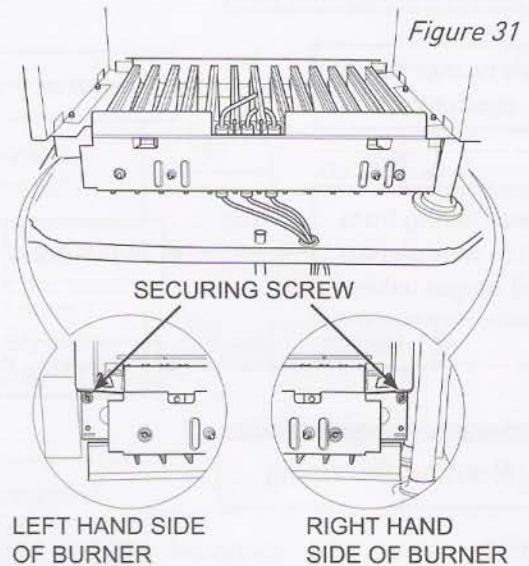
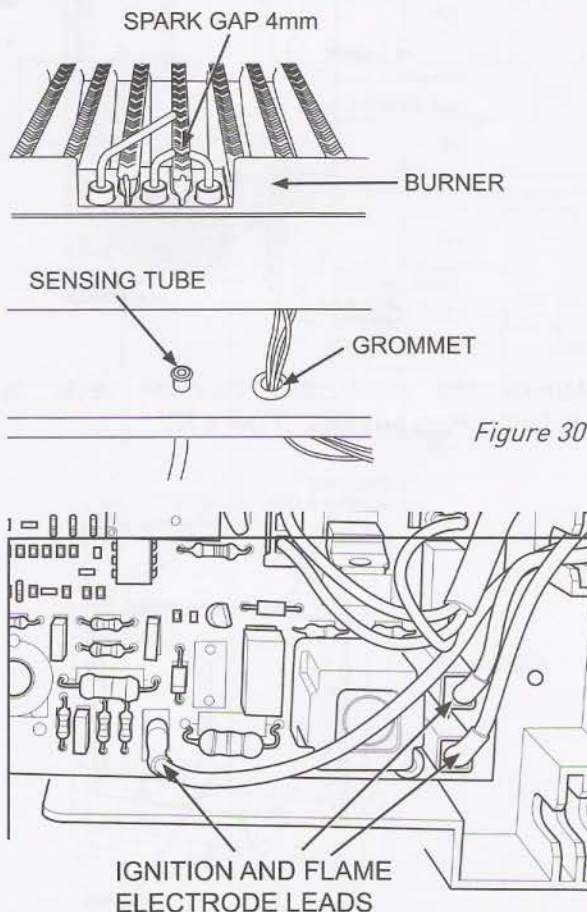

- Remove the burner-retaining screws at the sides and remove the burner.

18.9 Visually check for debris/damage and clean/replace as necessary the following items:

- ⇒ Heat exchanger
- ⇒ Burner
- ⇒ Fan/compartment
- ⇒ Electrodes
- ⇒ Insulation/gaskets

Note. All washers/gaskets must be retained for use on re-assembly, replace if damaged.

18.10 To clean the condensate trap, which is located at the back left hand corner of the appliance, remove the plastic hose from the outlet and insert a suitable allen key into the outlet and remove the sump by turning anti-clockwise. Clean the sump using a dilute solution of bleach. Apply a little silicone grease to the O ring and replace the sump so that the O ring is just engaged. Do not over tighten.

Important.

- ❖ Clean the heat exchanger using a soft brush or vacuum cleaner. Do not use any tool likely to damage painted finish of heat exchanger.
- ❖ Clean the burner by washing in soapy water. Allow to dry thoroughly before re-fitting.
- ❖ Do not use wire or a sharp instrument to clean the burner injectors.
- ❖ Ensure the ignition electrode gap is set to 4 mm.

18.11 The boiler is fitted with a cold water inlet filter which must be inspected on each service. To access the filter:

- Close the isolating valve on the boiler's cold water domestic inlet by turning the valve head fully clockwise.

- Open one or more hot water taps to drain the domestic hot water circuit.
- Disconnect the cold water inlet connection to the boiler.
- Clean and inspect the filter, replace if necessary as described in (18.20).
- Re-fit the filter and reinstate the cold water inlet connection to the boiler, fit new gasket as required.
- Fully open the isolating valve on boiler's cold water inlet and check for leaks.

18.12 On completing the service reassemble the boiler components in reverse order of removal, ensuring that all component joints and gaskets are sound. Any damaged seal or gasket must be replaced.

18.13 Reinstall the boiler's electrical and gas supplies and check for gas soundness and correct boiler operation.

CAUTION!

While there are no substances harmful to health contained within this appliance, some component parts of the boiler (insulation pads, gaskets and rope seals) are manufactured from man made fibres. When damaged or broken these fibres may cause a temporary irritation. High dust levels may irritate eyes and upper respiratory system. It is important therefore, that sensible precautions are applied when exchanging components.

19. Component Replacement

19.1 Ensure that both the electrical and gas supplies to the boiler are isolated before replacing any component part.

19.2 To prevent the need to drain the entire heating system when replacing the boiler's integral pump, expansion vessel, safety relief valve and pressure sensor, the boiler's hydraulic circuit may be isolated from the central heating circuit by closing the boiler's isolation valves. Opening the discharge valve will then drain the boiler's hydraulic circuit. Note clean the valve seat to ensure it seals before re-filling the boiler.

19.3 For replacement of the following components it will be necessary to remove the boiler casing panels as described in Section 17.

19.4 Domestic hot water sensor

- The domestic hot water sensor is located on the left side of the hydraulic block's hot water side. (Figure 32)
- Carefully disconnect the leads from the sensor.

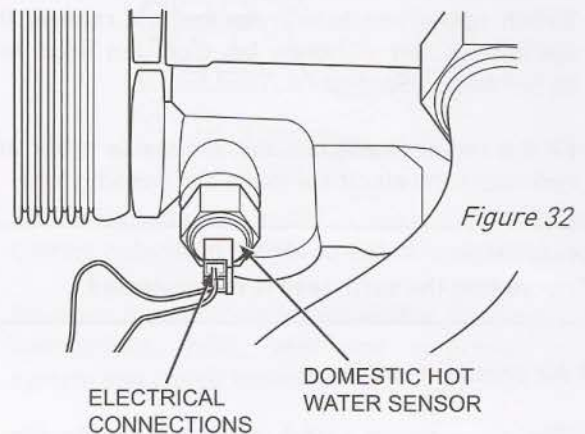

- Remove the sensor using a 13mm spanner.
- Fit the replacement sensor ensuring the washer is correctly fitted. Re-fit the leads to the replacement sensor

19.5 Central heating sensor

- The c/heating sensor is located on left side of the combustion chamber on the outlet of the primary heat exchanger. (Figure 33)
- Unclip the sensor from the pipe.
- Disconnect the leads from the sensor.

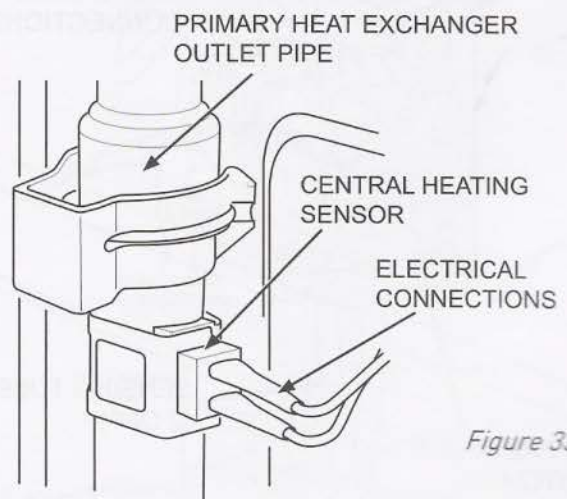

- Fit replacement sensor.
- Fit the leads and replacement the sensor.

19.6 Fan Unit

- Disconnect the electrical leads from the fan.
- To remove the fan, disconnect the 90° bend from the top of the boiler
- Disconnect the electrical leads and air pressure switch connection tube from the fan, remove the fan screws and withdraw fan from fan hood with its 56° bend. (Section 18.7)
- Fit the replacement fan unit in reverse order and reconnect the electrical leads and sensing tube.

WARNING!
Ensure that the earth lead is re-connected.

19.7 Air pressure switch

- The air pressure switch is located on the top of the expansion vessel. (Figure 34)
- Remove the sensing tube and electrical connections from the air pressure switch, noting which tube is connected to which port.
- Remove the air pressure switch by pulling forward off its bracket.
- Fit the replacement switch in reverse order of removal.

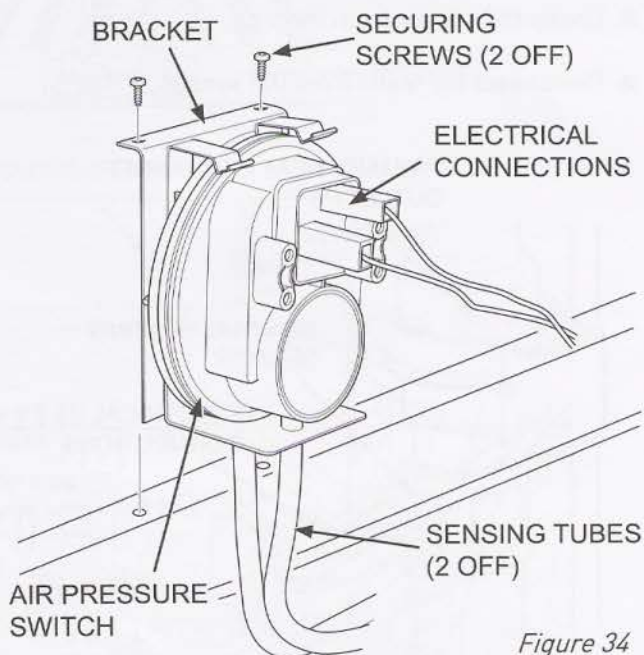

Figure 34

19.8 Burner

Note.
The replacement burner is supplied as component parts and requires assembly on site.

- Remove the burner assembly from the combustion chamber as detailed in Section 18.7 retaining all washers/gaskets for use on re-assembly.
- Remove the manifold as shown in Figure 31.
- Fit the manifold with new burner injectors and tighten, ensuring that the injector size, marked on each injector is the same as stated in the 'Technical Data' section for the type of gas being used.

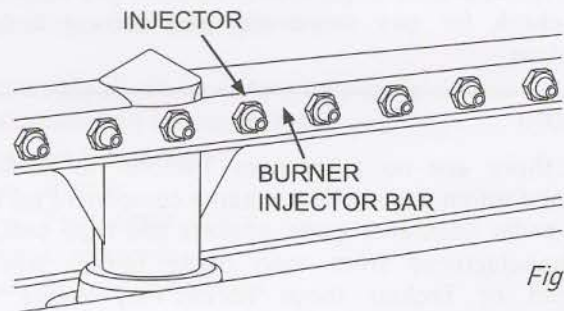

Figure 35

- Replace the burner bar and re-fit the burner blades (replace any damaged seals as necessary) and reassemble the boiler in reverse order.
- Check gas soundness and boiler operation.

19.9 Printed circuit board (PCB)

- Turn off and isolate the electrical supply.
- Remove the interface cover by lifting the two latches. (Figure 36-37)
- Remove the electrical connections to the PCB by pulling carefully, noting the locations of all the terminals.
- Release the screws securing the PCB to the control panel and lift out the PCB.
- Fit the replacement PCB in reverse order to removal, ensuring that the PCB electrical connections are fully pushed home.
- Check and re-set as necessary the potentiometers and dip switches to the same value as the old PCB.

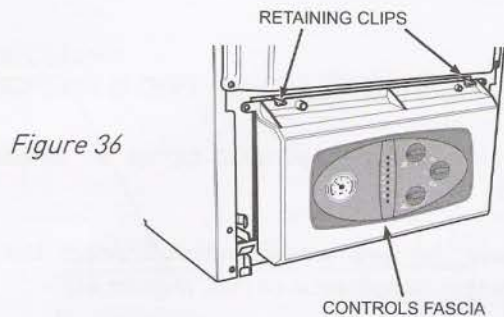

Figure 36

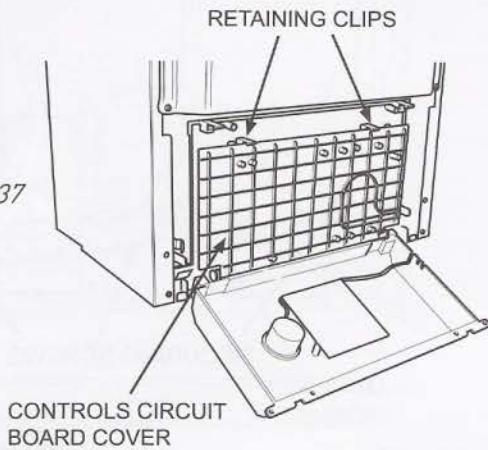

Figure 37

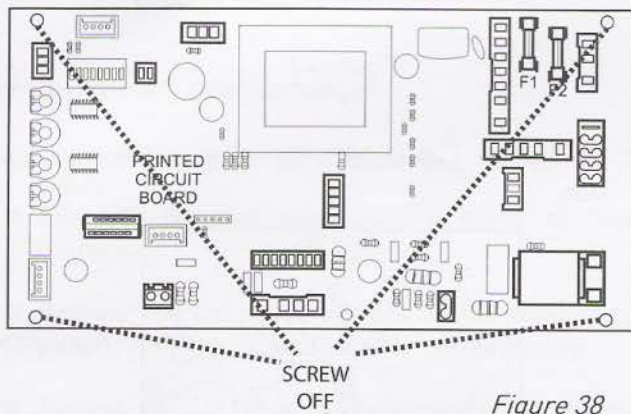

Figure 38

19.10 Pump

- Follow 18.10a or b depending on type of failure.

19.10a Replacing motor:

- Drain the boiler's hydraulic circuit as detailed in (19.2).
- Remove the screws shown in Figure 39.

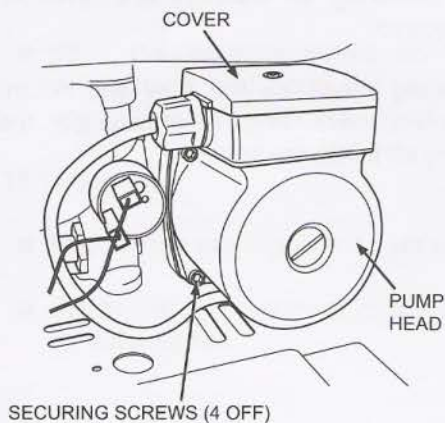

Figure 39

- Pull off the motor, remove the cover and disconnect the electrical leads from cable box Figure 40.

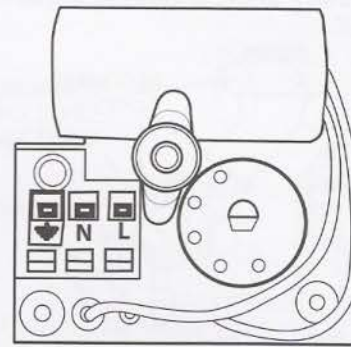

Figure 40

- Fit the replacement motor in reverse order ensuring correct polarity of the electrical connections.
- Re-open the isolating valves on the flow and return connections, refill, vent and re-pressurise the system and check for leakage.

19.10b Replacing the pump body:

- Remove the motor as described above.
- Remove the secondary water-to-water heat exchanger as detailed in (19.12).
- Remove the expansion vessel pipe by removing the clip on the pump body.
- Remove the pressure gauge connection as detailed in (19.11).
- Disconnect the electrical leads of low pressure sensor.
- Disconnect the pumps outlet fitting. (Figure 41)

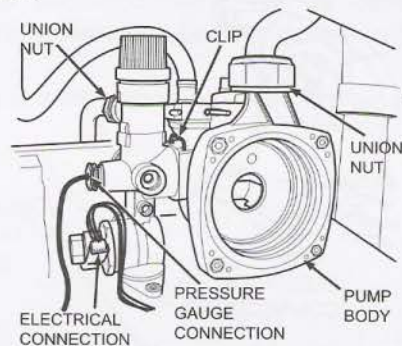
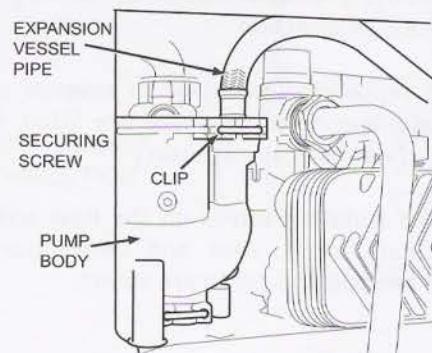

Figure 41



- Remove the fixing screws from the pump and hydraulic block at the bottom of the boiler (Figure 42).

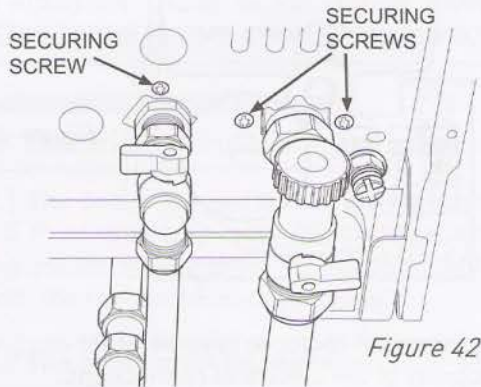

Figure 42

- Remove the pump assembly.
- Remove the pump body from the hydraulic assembly by releasing the clip.
- Fit the replacement body in reverse order ensuring that the pump washers are sound and fitted correctly and the polarity of the electrical connections are correct.
- Open the isolating valves on the low and return connections, refill, vent and re-pressurise the system ensuring all joints are sound.

19.11 Low water pressure sensor

- Drain the boiler's hydraulic circuit as detailed in (19.2).

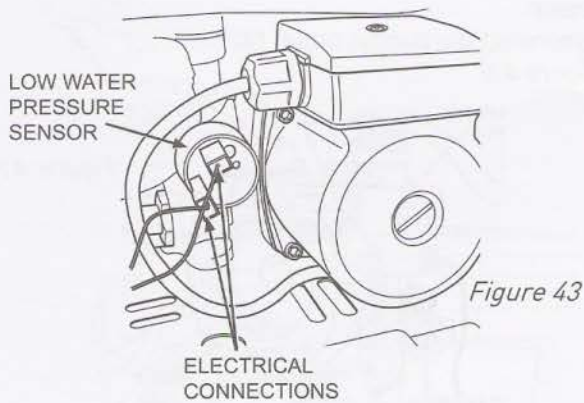

Figure 43

- Remove the pressure sensor by turning it in an anticlockwise direction.
- Fit the replacement sensor in reverse order of removal ensuring all washers are fitted. Replace damaged washers as necessary.
- Open the isolating valves on the flow and return connections, refill, vent and re-pressurise the system ensuring all joints are sound.

19.12 Secondary Heat Exchanger

- Drain the boiler's hydraulic circuit as detailed in (19.2)
- Remove the two screws which connect the heat exchanger to hydraulic circuit. (Figure 44)

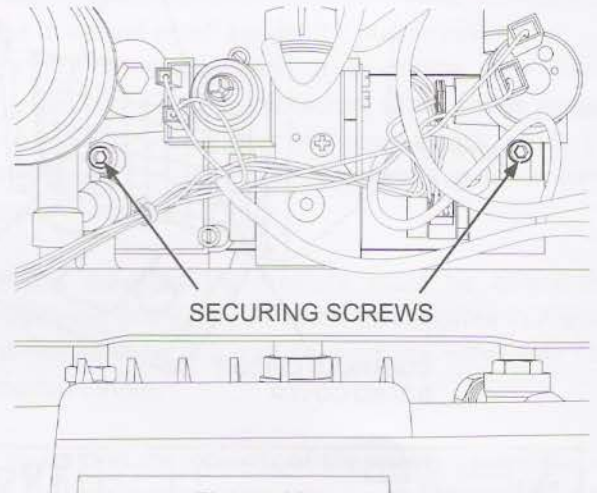

Figure 44

- Remove the exchanger from the gap on the left hand side.

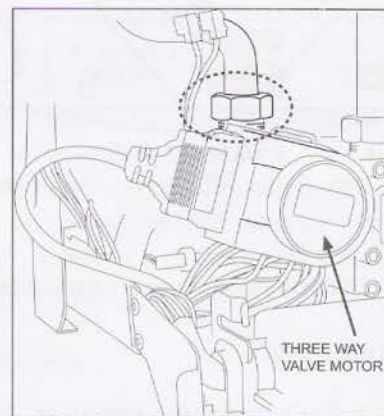

Figure 45

- Fit the new heat exchanger checking that the plate numbers are the same and reassemble the boiler in reverse order ensuring all washers are fitted or replaced as required.
- Open the isolating valves on the flow and return connections, refill, vent and re-pressurise the system ensuring all joints are sound.

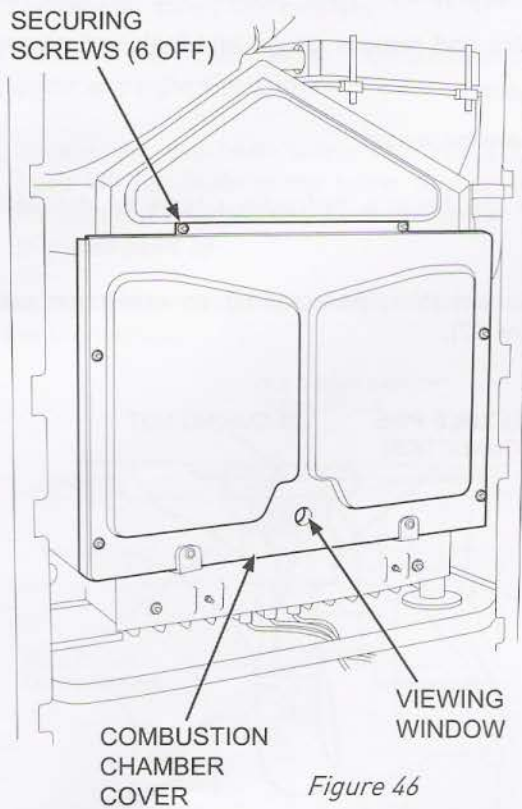

Figure 46

- Release the connection from gas valve and manifold inlet, retaining the washers for use on reassembly (Figure 47).

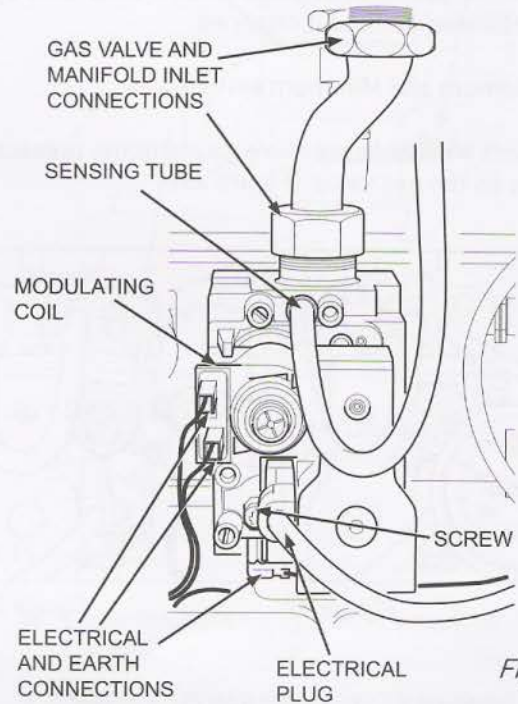

Figure 47

19.13 Primary Heat Exchanger

- Drain the boiler's hydraulic circuit as detailed in [19.2]
- Remove the pipe clips on the pipes of heat exchanger.
- Release the union connections on the connection pipes, retaining the washers for re-assembly.
- Remove the CH temperature sensor on the return pipe.
- Remove the pump-heat exchanger and heat exchanger-three way valve connection pipes.
- Remove the combustion chamber cover.
- Remove the heat exchanger by pulling forward.
- Fit the new heat exchanger and reassemble the boiler in reverse order ensuring all the washers are fitted, or replaced as required.
- Open the isolating valves on flow and return connections, refill, vent and re-pressurise system ensuring the all joints are sound.

19.14 Gas valve

- Ensure that gas supply to boiler is turned off.
- Disconnect the electrical connections to gas valve modulating coil.

- Release the main gas connection between the gas valve supply tube and gas inlet valve, retaining the washer for use on reassembly.
- Remove the gas valve's two securing screws and washers from the underside of the boiler. (Figure 48)
- Rotate the gas pipe and withdraw gas valve assembly.
- Refit in reverse order to removal, the polarity of the wires to the modulating coil is not important, replace any damaged washers as required.
- Check gas soundness and correct boiler operation.

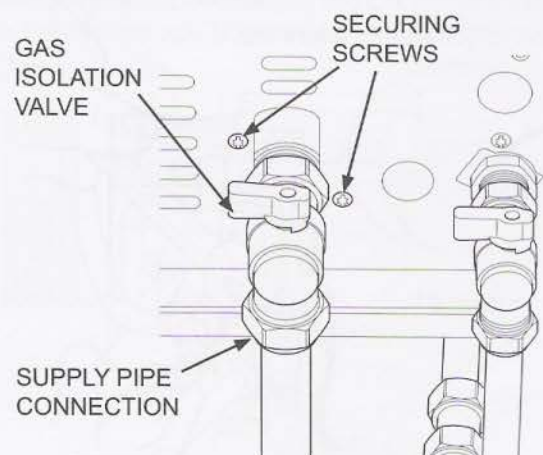

Figure 48

- Following replacement the maximum and minimum settings for natural gas must be checked to Technical data, section 2.
- Check the gas valve settings and re-calibrated by the following method if required:

19.15 Maximum and Minimum setting

- Connect a suitable pressure gauge to the pressure outlet on the gas valve. (Figure 49)

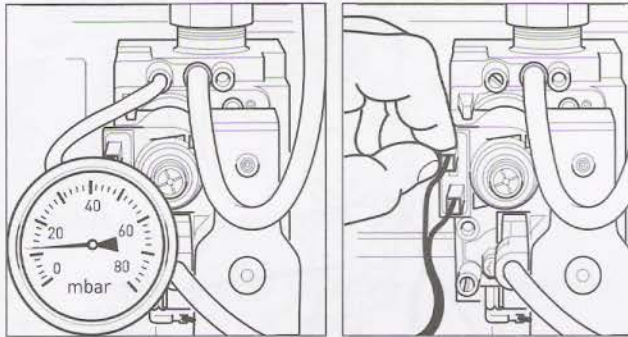

Figure 49

Figure 50

- Remove plastic cover from gas valve adjuster
- Create domestic hot water demand by operating a hot water faucet.
- Adjust 10 mm brass nut to gain correct maximum burner pressure ensuring the inner screw is held in place with the use of a cross head screw driver clockwise to increase, anti-clockwise to decrease. (Refer to Technical Data for pressure settings)
- Remove one lead from the modulating gas valve coil. (Figure 50)
- Adjust inner screw to give correct min burner pressure whilst holding 10 mm nut on maximum adjuster. Clockwise to increase, Anti-clockwise to decrease.

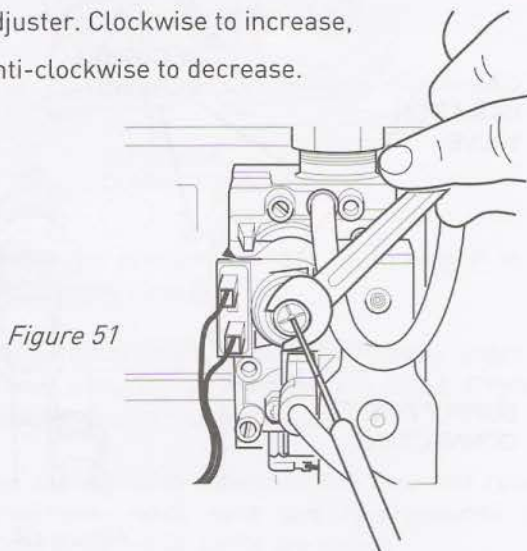

Figure 51

- Re-connect the lead of gas valve coil.

- After adjustment refit plastic cap on gas valve adjuster and remove gauge and leak test pressure test point.

19.16 Expansion vessel

- Drain the boiler's hydraulic circuit as detailed in (19.2)
- Disconnect the pipe coupling on expansion vessel (Figure 52).

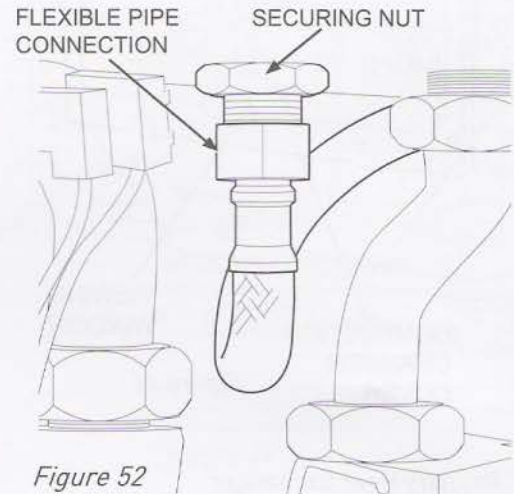

Figure 52

Release and remove the nut securing the expansion vessel to the boiler.

- Remove the side panels as described in section 18.4.
- Lift the vessel out of boiler from the gap over the chasis (Figure 53) and fit the replacement vessel to the boiler in reverse order to removal, ensuring that sealing washer is fitted to pipe connection before tightening, replace the washer if necessary.
- Using a pressure gauge, ensure that expansion vessel charge pressure is 0.5bar (7.5psi)

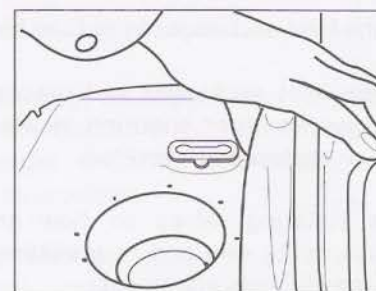

Figure 53

- Open the isolating valves on the flow and return connections, refill, vent and pressurise the boiler ensuring all joints are sound.

19.17 Overheat safety thermostats

- Remove the front panel, combustion chamber cover and right side panel.
- Locate the overheat safety thermostats at the front left handside of the boiler and on the right handside of the primary heat exchanger (Figures 54a & b)

Disconnect the electrical connections from the thermostat.

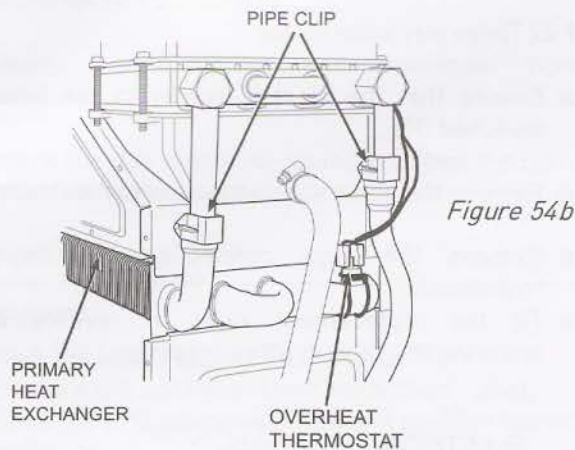
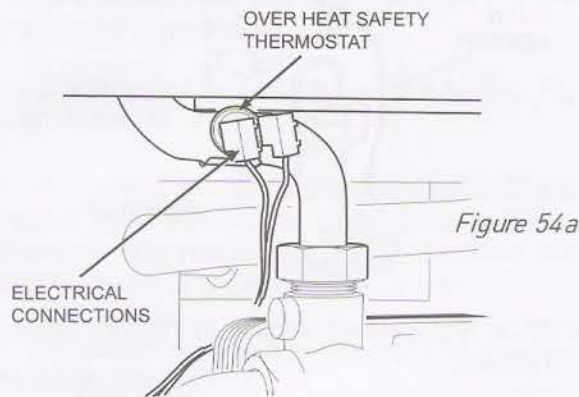

- Unclip the thermostat from the pipe.
- Fit the replacement thermostat in reverse order of removal.

19.18 Pressure relief valve (Figure 55).

- Drain the boiler's hydraulic circuit as detailed in (19.2).
- Disconnect the discharge pipe on the outlet of the safety valve.
- Remove the safety valve from the hydraulic block and retain the o-ring for use on reassembly, replace as necessary.
- Fit the replacement safety valve in reverse order to removal and refill, vent and pressurise boiler ensuring all joints are sound.

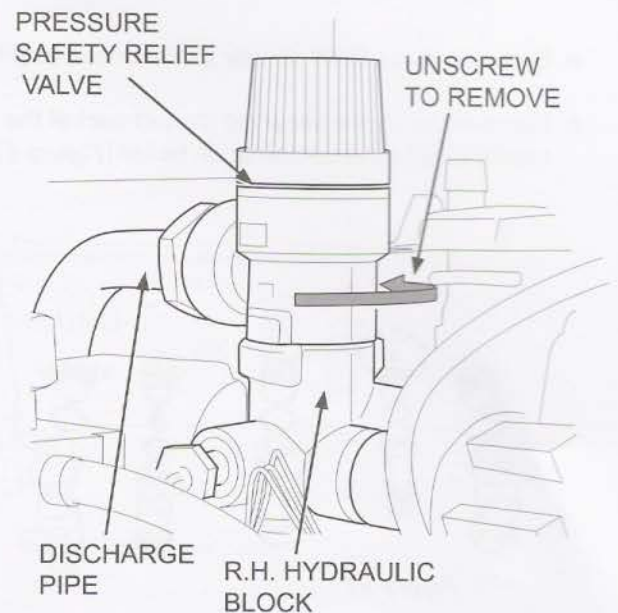

Figure 55

19.19 Hydroblock

- Drain the boiler's hydraulic circuit as detailed in (19.2).
- Remove the secondary heat exchanger as described in (19.12)
- Remove the pump assembly as described in (19.10)
- Remove the section of the hydroblock from the pump by releasing the clip.
- Release the exchanger outlet pipe nut and rotate the pipe for easy removal of the left section of the hydroblock as described in section (19.13)
- Disconnect the three way valve motor, electrical connection and remove the motor by releasing the clip as described in section (19.22)
- Release the nut connecting the CH outlet connection to the hydroblock. (Figure 56).

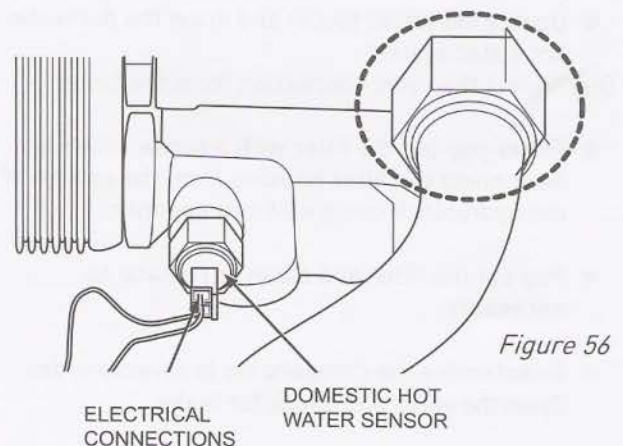

Figure 56

- Disconnect the DHW sensor as described in (19.4).
- Remove the screw securing the left part of the hydroblock to the combination boiler (Figure 57).

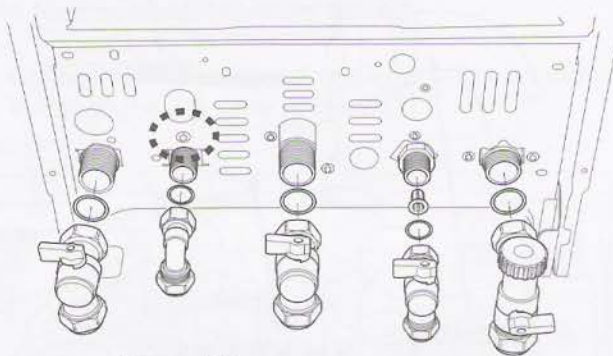

Figure 57

- Fit the replacement hydroblock parts in reverse order to removal ensuring all seals are correctly located and replaced if necessary.
- Open the isolating valves on the flow and return connections, refill, vent and pressurise boiler ensuring all joints are sound.

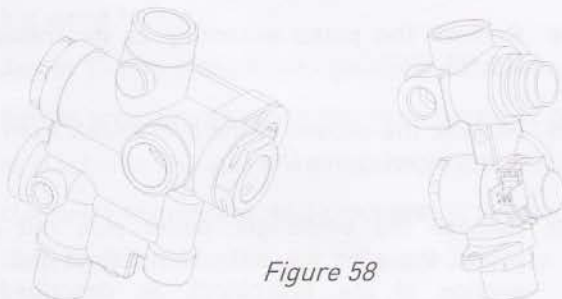

Figure 58

19.20 Filter.

- Switch off the electrical supply to the boiler.
- Close the domestic cold water supply valve below the boiler (Second valve on the right)
- Open a hot water faucet and drain the domestic hot water system.

Disconnect the valve connection from the boiler

- Either pop out the filter with a screw driver or disconnect the filter housing from the bottom of the hydroblock using a 24mm spanner.
- Pop out the filter and clean or replace as necessary.
- Reassemble the components in reverse order. Open the valve and check for leaks.

19.21 Flow sensor

- Remove the flow sensor using a pair of pliers.

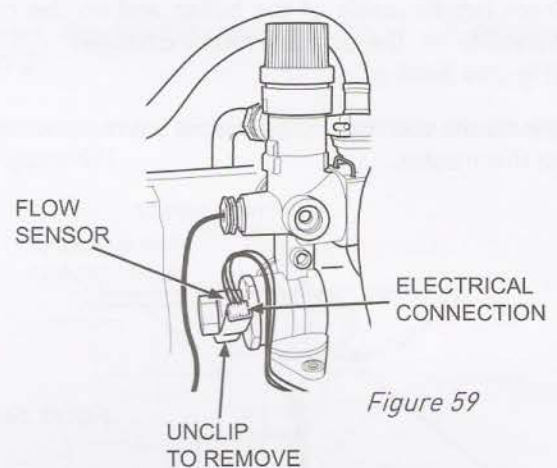

Figure 59

- Fit a replacement sensor in reverse order to removal.

19.22 Three way valve motor

- Ensure that the electric supply to the boiler is switched OFF.
- Remove the electrical connection to the motor.
- Remove the clips connecting the valve to hydroblock.
- Fit the replacement valve in reverse order ensuring the valve is fitted properly.

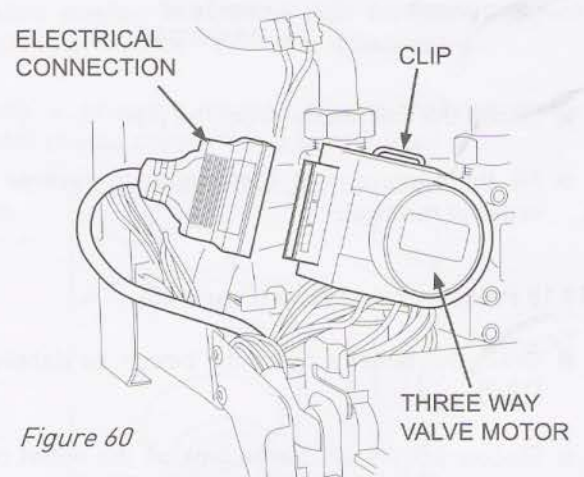

Figure 60

20. Gas Type Conversion

Warning

Gas conversion must be carried out by a competent person as defined in the Gas Safety and Use Regulations.

If gas type conversion is required (from NG to LPG etc.), follow the steps below:

- The burner must be removed as 18.8 (shown Figure 31.)
- Fit the injector bar and tighten, ensuring that the injector size, marked on each injector is the same as stated in the relevant section of the 'Technical Data' for the type of gas that will be used.
- Fit the burner (replace if necessary) and reassemble the boiler.
- Check for gas soundness.
- Check the minimum and maximum burner pressures.
- Check the gas circuit for soundness and the correct operation of the boiler.

Important.

Attach the labels supplied as follows:

- Replace the adhesive "User Instruction" label.
- Stick the LPG label in a prominent position within the boiler.
- Stick the foil label over the existing gas type on the data plate of the boiler.

SHOULD YOU SMELL GAS: Turn the gas valve off at the Gas Meter or Gas Cylinder, ventilate the room by opening windows and doors (EXTINGUISH ANY NAKED FLAMES, DO NOT OPERATE ANY ELECTRICAL SWITCHES) and call Transco on 0800 111 999 or if you use LPG call your gas supplier.

APPENDICES

SPARE PARTS LIST

PART No.	DESCRIPTION	ORDER CASE
1	HYDROBLOCK - THREE WAY VALVE PART	3003200017
2	HYDROBLOCK - PUMP PART	3003201529
3	LOW PRESSURE SWITCH	3003200038
4	SAFETY VALVE	3003200019
5	PUMP	3003201336
6	EXPANSION VESSEL	3003200028
7	GAS VALVE	3003200419
8	BURNER (WITH MANIFOLD-NG)	3003202153
9	CONTROL PANEL	3003200441
10	PCB COVER	3003200084
11	ELECTRONIC CONTROL BOARD	3003202166
12	SECONDARY HEAT EXCHANGER	3003200026
13	INTERFACE CARD	3003201124
14	CH SENSOR	3003200152
15	WATER PRESSURE GAUGE	3004090673
16	OVERHEAT SAFETY THERMOSTAT	3002185050
17	IGNITION ELECTRODE - RIGHT	3003202200
18	IGNITION ELECTRODE - LEFT	3003202201
19	FLAME SENSE ELECTRODE	3003202102
20	FAN	3003202165
21	AIR PRESSURE SWITCH	3003200032
22	FRONT PANEL	3003200449
23	CONDENSATE TRAP	3003201775
24	TURBO EXCHANGER	3003200486
25	WIRING HARNESS	3003202230



B24

Condensing Wall Mounted Combination Boiler

User Instructions

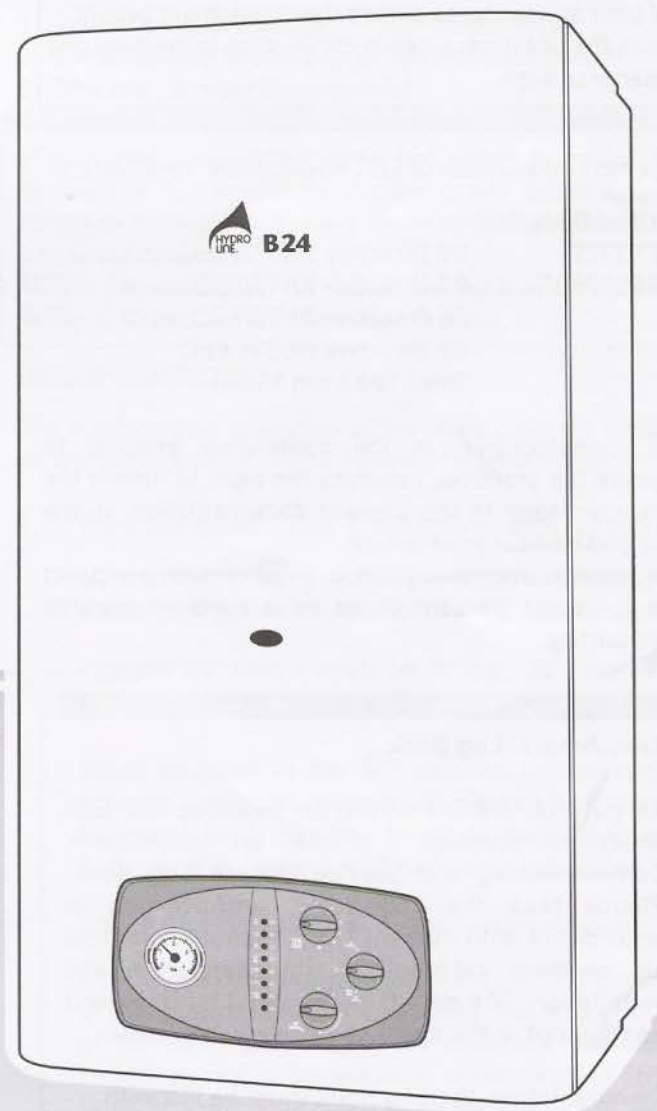

Natural Gas / LPG

Hydroline B24
Condensing Combination Boilers

British Gas Service Listing
This boiler has been 'Service Listed' by British Gas and has been designated with the following G.C No . 47-157-18



The Hydroline™ central heating boiler is manufactured from high quality materials, enabling reliability and optimum performance.

Hydroline™ is committed to the continual development of their appliances to ensure their customers benefit from the latest advances in combustion technology and energy savings.

Type test for purpose of EEC Regulations certified by:

Notified Body IMQ
51BP2727 CE Directive 90/396/EEC
51BP2728DR CE Directive 92/42/EEC
CE Directive 73/23/EEC
CE Directive 89/396 EEC
(modified from 93/68)

The manufacturer, in the continuous process to improve his products, reserves the right to modify the data expressed in the present documentation at any time and without prior notice.

The present documentation is an informative support and it cannot be considered as a contract towards third parties.

'Benchmark' Log Book

As part of the industry-wide initiative the B24 boiler is supplied with an Installation, Commissioning and Service Record Log Book. Please read the Log book carefully and in accordance with current requirements complete all sections relevant to the appliance and installation. The details within the Log Book will be required in the event of any warranty work.

On completion, the Log Book must be left with the end user and the relevant sections completed on each subsequent Service visit.

IMPORTANT INFORMATION

The Hydroline™ B24 is a high efficiency gas fired combination boiler and represents the highest level of technology found in today's gas boiler market.

In order to maintain peak efficiency and performance your boiler must be serviced annually. This should be undertaken by a competent CORGI registered engineer. Failure to undertake this service work may invalidate your warranty.

All CORGI Registered Installers carry a CORGI ID card and have a registration number, which should be recorded and entered on your Benchmark log book. You can check your Installer registration by contacting CORGI on 0800 915 0480.

The boiler's 'Log Book' must be completed at each Service visit.

GAS SAFETY (INSTALLATION AND USE) REGULATIONS

It is a legal requirement that all gas appliances must be installed and serviced by a competent person in accordance with the regulations. Failure to install or service gas appliances correctly could lead to prosecution. It is in your interest and that of safety to ensure compliance with the law. For electrical safety the boiler must be earthed and protected by a 3-amp fuse.

Note. In the event of a fault the appliance should not be used until fault has been rectified by a competent person.

VENTILATION

On installation the boiler must be installed with minimum clearances of 50mm each side, 200mm above, 300mm below with 600mm access to the front. If an opening door is to be fitted across the front of the boiler allow 5 mm clearance to the front panel.

Should the boiler be installed in a closed compartment it is recommended that there are minimum air vents of 30 square cm at both high and low levels.

GENERAL DESCRIPTION OF BOILER

The B24 is a combined domestic hot water and central heating appliance. The internal control unit electronically provides direct burner ignition and combustion supervision along with continuous modulation of the burner's gas supply.

By means of a manual switch the boiler can be set to operate in one of two operating modes, domestic hot water only or domestic hot water and central heating.

DOMESTIC HOT WATER MODE:

When hot water demand is requested the boiler will fire automatically. An integral pump is then energised and hot water from the boiler's primary circuit is circulated through the secondary heat exchanger, allowing the instantaneous transferral of heat to the incoming cold water. The secondary heat exchanger is protected against an internal build up of lime scale by limiting the hot water temperature at the tap to a maximum of 64°C. Hot water will continue to flow through the tap until no longer required. When the demand for hot water ceases the integral pump may continue to run for a short while to dissipate any excess heat within the boiler.

DOMESTIC HOT WATER AND CENTRAL HEATING MODE:

When heating demand is requested the boiler will fire automatically. An integral pump is then energised and hot water from the boiler's primary circuit is circulated around the heating systems pipe-work and radiators. The heat output from the boiler is automatically adjusted by the boiler's internal control unit to match the heating demand. As the water temperature of the heating system increases the gas input to the burner decreases, conserving energy and increasing efficiency. When the demand for heating no longer exists, either the room thermostat is satisfied or the heating period has ended, the burner will shut down and the boiler will revert to stand-by, waiting to respond to the next heating demand. The integral pump may continue to run after shut down for a short while to dissipate any excess heat within the boiler.

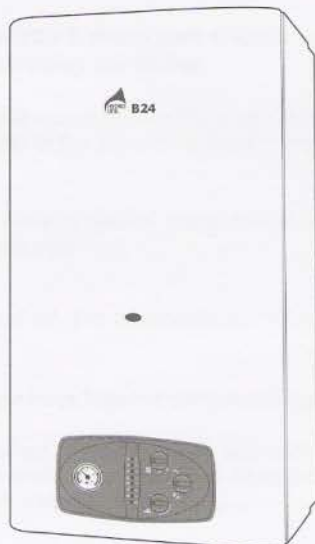

Figure 1

ACCESS TO THE BOILER CONTROLS

The boiler controls are sited at the bottom of the boiler's front case. (figure 1)

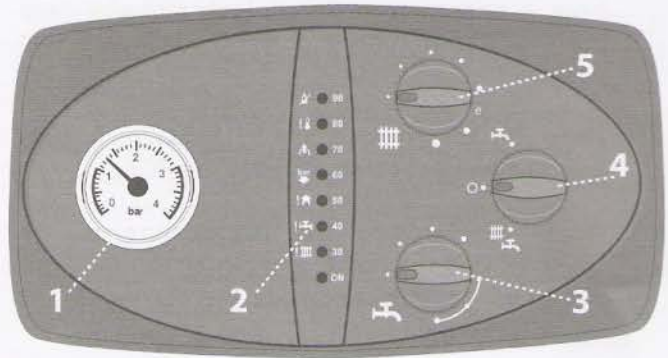

Figure 2



- 1- System pressure gauge
- 2- LED Display
- 3- D.H.W. temperature control
- 4- Function switch
- 5- C/heating temperature control



Please Note. When domestic hot water is called for during the heating mode, the boiler will automatically revert to domestic hot water mode until the demand for hot water ceases.

NOTE: Depending on the boiler set up there may be a delay of 45secs before the boiler re-fires.

BOILER CONTROLS

The function and operation of the main controls located on the control panel fascia (figure 2) is as follows:

1. Function switch. This is the boiler's main operating switch. In the  position the boiler is in stand-by mode and power supply is ON. For the boiler to operate the switch must be in the  or  position.

When switched to the  position the boiler will operate only to supply domestic hot water. [Summer use] For the boiler to operate to give both central heating and domestic hot water the switch must be in the  position [Winter use]

2. Central Heating temperature control. The position of this control dial will determine the temperature of the water delivered to the radiators. The water temperature can be set from a minimum of 30° C (anticlockwise stop position) to a maximum of 85° C (clockwise stop position.)

3. **D.H.W. temperature control** The position of this control dial will determine the temperature of the domestic hot water delivered to the taps or shower unit. The water temperature can be set from a minimum of 35° C (anticlockwise stop position) to a maximum of 64° C (clockwise stop position.)
4. **Boiler On** The boiler 'Stand by' indicator (green) lights when power is supplied to the PCB.
5. **Water Temperature** The temperature of the water leaving the boiler is given by the red light indicators situated alongside the burner 'Stand by' indicator light.
6. **Fault Indicator** The control unit has an in-built fault diagnostic function. When a fault occurs, the type of fault is indicated by the appropriately 'flashing' red light indicator. A listing of the display lights and meanings can be found in Section 13 of the Installation and Servicing Instructions.
7. **Boiler Lockout** When the first red light indicator from right (flame or gas fault) or the second from right (overheat fault) lights, the boiler will need to re-set. To re-set the boiler the function switch must be switched to the  position and after 30 seconds back to its previous (summer or winter) position.
8. **Pressure gauge** The pointer on the gauge indicates the pressure within the boiler and central heating system and should, when the water is cold, read between 1 and 2bar.

If the pressure gauge falls below 1bar the system and boiler must be re-pressurised via the filling loop. The filling loop should be located below the boiler.

Note. A Service Engineer must be contacted if a boiler fault continues to occur.

FROST PROTECTION

The boiler has a built in frost protection device that protects the boiler from freezing. If the boiler is to be left and there is a risk of frost, ensure that the gas and electrical supplies are left connected. The frost protection device will light the boiler when the temperature of the boiler water falls below 6°C. When the temperature reaches 15°C, the boiler will shut down.

Note: This device works irrespective of any room thermostat setting and will protect the boiler,

but not necessarily the full system. Ensure that vulnerable sections of the circuit are adequately lagged.

SYSTEM PRESSURE

On installation your installer will have filled the boiler and system to its effective working pressure. The boiler's pressure gauge should be regularly checked to ensure that this pressure is maintained between 1 and 2 bar. If there is a significant or frequent drop in pressure then your installer should be consulted.

OPERATING THE BOILER

On installation your installer will have filled the boiler and system to its effective working pressure. The boiler's pressure sensor should be regularly checked on the LED to ensure that this pressure is maintained between 1 and 2 bar. If there is a significant loss in pressure the boiler will lock out. The system may be re-charged by opening the filling loop to charge the system back up to 1.5 bar as indicated on the LED panel. **DO NOT OVERCHARGE THE BOILER PRESSURE BEYOND 2 BAR AS THE BOILER WILL NOT OPERATE.** The filling loop, a flexible hose with two valves, should be located below the boiler connecting the second pipe on the right to either one of the outer pipes, see *Figure 10*. **DO NOT CLOSE ANY OF THE FOUR VALVES DIRECTLY CONNECTING TO THE BOILER.** If the boiler frequently loses pressure then your installer should be consulted.

CLEANING

The boiler casing may be cleaned with a damp cloth followed by a dry cloth to polish. Do not use abrasive or solvent cleaners.

FURTHER ADVICE

For further advice or information contact Hydroline™ Service Enquiries by telephone on **01234 329 107** or e-mail at our web site **www.hydroline.co.uk**

For technical information, please contact Hydroline™ Technical on **01234 329 106**.



The code of practice for the installation,
commissioning & servicing of gas central heating

Installation, Commissioning and Service Record Log Book

INSTALLER & COMMISSIONING ENGINEER DETAILS

COMPANY NAME _____ INSTALLATION DATE _____
 ADDRESS _____

 INSTALLER'S NAME _____ TEL No. _____
 CORGI REGISTRATION DETAILS
 REG No. _____ CORGI ID SERIAL No. _____

NAME _____ COMMISSIONING DATE _____
 ADDRESS _____

 TEL No. _____
 CORGI REGISTRATION DETAILS
 REG No. _____ CORGI ID SERIAL No. _____

APPLIANCE & CONTROL DETAILS

BOILER

MAKE AND MODEL _____
 APPLIANCE SERIAL No. _____ SEDBUK No. %
 LOCATION _____
 NEW SYSTEM or REPLACEMENT BOILER

CONTROLS

To comply with the Building Regulations, each section must have a tick in one or other of the boxes.

REQUIREMENT	MEASURES PROVIDED	
1. TIME AND TEMPERATURE CONTROL TO HEATING	ROOM STAT & PROGRAMMER/TIMER <input type="checkbox"/>	PROGRAMMABLE ROOMSTAT <input type="checkbox"/>
2. TIME AND TEMPERATURE CONTROL TO HOT WATER	CYLINDER STAT & PROGRAMMER/TIMER <input type="checkbox"/>	COMBI BOILER <input type="checkbox"/>
3. HEATING ZONE VALVES	FITTED <input type="checkbox"/>	NOT REQUIRED <input type="checkbox"/>
4. THERMOSTATIC RADIATOR VALVES	FITTED <input type="checkbox"/>	
5. AUTOMATIC BYPASS TO SYSTEM	FITTED <input type="checkbox"/>	NOT REQUIRED <input type="checkbox"/>
6. BOILER INTERLOCK	PROVIDED <input type="checkbox"/>	

PLEASE FOLLOW THE INSTALLATION AND COMMISSIONING INSTRUCTIONS
IN THE INSTALLATION MANUAL SUPPLIED WITH THE EQUIPMENT

NAME _____
 ADDRESS _____
 _____ TEL No. _____

- Please keep the Log Book in a safe place future reference.
- This Log Book is to be completed in full by the competent person(s) who commissioned the boiler and associated equipment and then handed to the customer. When this is done, the Log Book is a commissioning certificate that can be accepted as evidence of compliance with the appropriate Building Regulations.
- Failure to install and commission this appliance to the manufacturer's instructions may invalidate the warranty.

The above does not affect your statutory rights.

The content of this Log Book has been produced in consultation with



© CENTRAL HEATING INFORMATION COUNCIL

Benchmark is supported by



COMMISSIONING PROCEDURE INFORMATION

FOR ALL BOILERS

HAS THE SYSTEM BEEN FLUSHED IN ACCORDANCE WITH THE BOILER MANUFACTURER'S INSTRUCTIONS? YES NO

WHAT WAS THE CLEANSER USED? _____

HAS AN INHIBITOR BEEN USED? YES NO

WHICH INHIBITOR WAS USED? _____

FOR THE CENTRAL HEATING MODE, MEASURE AND RECORD

HEAT INPUT _____ kW

BURNER OPERATING PRESSURE _____ mbar

CENTRAL HEATING FLOW TEMPERATURE _____ °C

CENTRAL HEATING RETURN TEMPERATURE _____ °C

FOR COMBINATION BOILERS ONLY

HAS A WATER SCALE REDUCER BEEN FITTED? YES NO

WHAT TYPE OF SCALE REDUCER HAS BEEN FITTED? _____

FOR THE DOMESTIC HOT WATER MODE, MEASURE AND RECORD

MAXIMUM OPERATING WATER PRESSURE _____ bar

COLD WATER INLET TEMPERATURE _____ °C

HOT WATER OUTLET TEMPERATURE _____ °C

WATER FLOW RATE AT MAXIMUM SETTING _____ lts/min

FOR CONDENSING BOILERS ONLY

HAS THE CONDENSATE DRAIN HAS BEEN INSTALLED IN ACCORDANCE WITH THE MANUFACTURER'S INSTRUCTIONS? YES NO

FOR ALL INSTALLATIONS

DOES THE HEATING AND HOT WATER SYSTEM COMPLY WITH THE APPROPRIATE BUILDING REGULATIONS? YES

HAS APPLIANCE AND ASSOCIATED EQUIPMENT BEEN INSTALLED AND COMMISSIONED IN ACCORDANCE WITH THE MANUFACTURER'S INSTRUCTIONS? YES

HAVE YOU DEMONSTRATED THE OPERATION OF THE APPLIANCE AND SYSTEM CONTROLS TO THE CUSTOMER? YES

HAVE YOU LEFT ALL THE MANUFACTURER'S LITERATURE WITH THE CUSTOMER? YES

COMPETENT PERSON'S SIGNATURE _____ CUSTOMER'S SIGNATURE _____

(To confirm demonstrations of equipment and receipt of appliance instructions)

SERVICE INTERVAL RECORD

It is recommended that your heating system is serviced regularly and that your service engineer completes the appropriate Service Interval Record below.

SERVICE PROVIDER

Before completing the appropriate Service Interval Record below, please ensure you have carried out the service as described in the boiler manufacturer's instructions and in compliance with The Gas Safety Regulations. Always use the appliance manufacturer's specified spare part when replacing gas controls.

SERVICE 1 DATE _____

ENGINEER NAME _____

COMPANY NAME _____

TEL No. _____

CORGI ID SERIAL No. _____

COMMENTS _____

SIGNATURE _____

SERVICE 3 DATE _____

ENGINEER NAME _____

COMPANY NAME _____

TEL No. _____

CORGI ID SERIAL No. _____

COMMENTS _____

SIGNATURE _____

SERVICE 5 DATE _____

ENGINEER NAME _____

COMPANY NAME _____

TEL No. _____

CORGI ID SERIAL No. _____

COMMENTS _____

SIGNATURE _____

SERVICE 7 DATE _____

ENGINEER NAME _____

COMPANY NAME _____

TEL No. _____

CORGI ID SERIAL No. _____

COMMENTS _____

SIGNATURE _____

SERVICE 9 DATE _____

ENGINEER NAME _____

COMPANY NAME _____

TEL No. _____

CORGI ID SERIAL No. _____

COMMENTS _____

SIGNATURE _____

SERVICE 2 DATE _____

ENGINEER NAME _____

COMPANY NAME _____

TEL No. _____

CORGI ID SERIAL No. _____

COMMENTS _____

SIGNATURE _____

SERVICE 4 DATE _____

ENGINEER NAME _____

COMPANY NAME _____

TEL No. _____

CORGI ID SERIAL No. _____

COMMENTS _____

SIGNATURE _____

SERVICE 6 DATE _____

ENGINEER NAME _____

COMPANY NAME _____

TEL No. _____

CORGI ID SERIAL No. _____

COMMENTS _____

SIGNATURE _____

SERVICE 8 DATE _____

ENGINEER NAME _____

COMPANY NAME _____

TEL No. _____

CORGI ID SERIAL No. _____

COMMENTS _____

SIGNATURE _____

SERVICE 10 DATE _____

ENGINEER NAME _____

COMPANY NAME _____

TEL No. _____

CORGI ID SERIAL No. _____

COMMENTS _____

SIGNATURE _____

When all of the above services have been completed. Please contact your Service Engineer for an additional service interval record sheet.



B24

For further information or advice contact Hydroline™

Service & Technical Enquiries in the UK:

Service: 08444 810 218

Sales: 01234 334 667

Technical: 01234 329 106