

Operating, Installation and Maintenance Manual for AtmoGas AG140 - AG340 boilers.

Hoval

AG 006 / October 2000



Contents

Introduction	2
1. General	3
1.1 Technical specifications	3-4
1.2 Main dimensions	5
2. Description	5-6
3. Installing and connecting the boiler	7
3.1 Boiler location	7-8
3.2 Gas connections	9
3.3 Flues and chimneys	9-10
3.4 Hydraulic connections	11
3.5 Filling the system	11
4. Setting the pressure at the injection nozzles to adapt the boiler power	12
5. Setting pressures and calibrated injection nozzle markings	13
6. Commissioning	14
6.1 Checks required before starting up the boiler .	14
6.2 Starting up	14-15
7. Fitting a TopTronic controller	15-16
8. Electrical connections .	16-18
9. Maintenance	19
9.1 Cleaning the burner	19
9.2 Cleaning the heating sections	20
9.3 Painted surfaces.	20
9.4 Identification plate	20
10. Exploded view diagrams and list of spare parts .	21-30

1. General

AtmoGas AG boilers are cast-iron boilers with a two stages atmospheric gas burner and electronic ignition via an ignition burner. They are designed for use with a hot-water central heating system, and have an output rating of 140 - 340 kW. They need to be connected to a suitable chimney.

AtmoGas AG boilers are supplied with a standard control panel which may be supplemented with an optional TopTronic controller for enhanced control features.

1.1 Technical specifications

Certification : AtmoGas AG boilers meet the requirements of the following European directives and standards :

- 90.396 EEC Directive relating to appliances burning gaseous fuels
Concerned standards : EN 297 / Pr EN 656
- 92.42 EEC Efficiency Directive
- 73.23 EEC Directive relating to electrical equipment designed for the use within certain voltage limits
Concerned standards : EN 60.335.1
- 90.336 EEC Directive relating to electromagnetic compatibility
Concerned standards : EN 50.081.1 / EN 50.082.1 / EN 55.014

Country of destination	GB
Class	I 2H
Type of gas	G20
Distribution pressure (mbar)	20

The boilers are of the B11 type (B11BS when fitted with the optional combustion product removal monitoring system).

The boilers may be used with type H natural gas (G20).

Type of boiler			AG 140	AG 160	AG 180	AG 200	AG 220	AG 260	AG 300	AG 340
Output power	2nd stage	kW	119 to 140 (1)	136 to 160 (1)	153 to 180 (1)	170 to 200 (1)	187 to 220 (1)	221 to 260 (1)	255 to 300 (1)	289 to 340 (1)
	1st stage	kW	83.5 to 98 (1)	95 to 112 (1)	107 to 126 (1)	119 to 140 (1)	131 to 154 (1)	155 to 182 (1)	179.5 to 210 (1)	202.5 to 238 (1)
Input power	2nd stage	kW	133.7 to 156.1	153.3 to 179	171.3 to 200	190.2 to 222	208.9 to 243.9	247.5 to 288.9	283.6 to 331.1	322.2 to 376.1
	1st stage	kW	95.2 to 111	108.7 to 127.4	121.6 to 142.4	135.1 to 158	148.5 to 173.6	176.1 to 205.6	201.5 to 235.7	229.1 to 267.7
Number of sections			8	9	10	11	12	14	16	18
Mass flue gas flow rate (as per DIN)	2nd stage	kg/hr	357	410	445	508	558	609	641	728
	1st stage	kg/h	360	413	443	512	563	591	600	682
Flue gas temperature (2)	Boiler temp. 80°C	°C	130	130	135	130	130	140	150	150
	Boiler temp. 50°C	°C	115	115	120	115	115	125	135	135
CO ₂ (2)	2nd stage	%	6.4	6.4	6.6	6.4	6.4	7	7.7	7.7
	1st stage	%	4.4	4.4	4.6	4.4	4.4	5	5.7	5.7
Ionising current		µA	> 20	> 20	> 20	> 20	> 20	> 20	> 20	> 20
Partial vacuum required at the nozzle		daPa	0.7	0.7	0.7	0.7	0.7	0.7	0.7	0.7
Minimum water flow temperature		°C	40	40	40	40	40	40	40	40
Maximum water flow temperature		°C	85	85	85	85	85	85	85	85
Maximum operating pressure		bar	6	6	6	6	6	6	6	6
Electrical connections		V / Hz	230 / 50	230 / 50	230 / 50	230 / 50	230 / 50	230 / 50	230 / 50	230 / 50
Electrical power		W	450	450	450	450	450	450	450	450
Gas connection 20 mbar		Inch	1 1/2"	1 1/2"	1 1/2"	1 1/2"	1 1/2"	1 1/2"	2"	2"
Heating connections		Inch	2"	2"	2"	2 1/2"	2 1/2"	2 1/2"	2 1/2"	2 1/2"
Diameter of flue connection		mm	250	250	300	300	300	350	350	350
Water content		litres	61	68	76	84	91	106	122	137
Hydraulic resistance	at Δ T = 10 K	mbar	32	48	60	84	104	208	284	388
	at Δ T = 15 K	mbar	15	21	27,5	38	47	93	127	172
	at Δ T = 20 K	mbar	8	12	15	21	26	52	71	97
Net weight without water		kg	575	635	690	750	805	920	1035	1150

(1) Factory setting

(2) At factory-set output power

1.2 Main dimensions

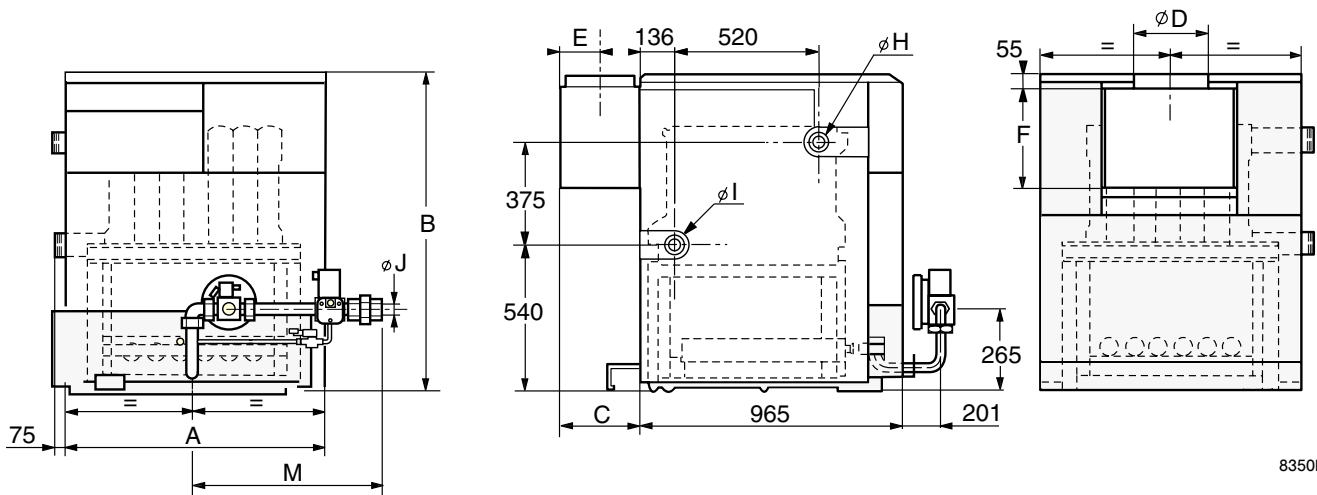

8350N001 B

- H** Threaded water flow tapping
I Threaded water return tapping
J Tapped gas inlet

H/I and J connections above may be made on the right or left-hand side of the boiler.

Note : flow and return connections should always be on the same side of the boiler.

	A	B	C	D	E	F	H/I	øJ	M
AG 140	1044	1210	292	250	138	370	2"	1"	660
AG 160	1132	1210	292	250	138	370	2"	1"	660
AG 180	1220	1210	331	300	163	370	2"	1"	660
AG 200	1308	1310	331	300	163	470	2 1/2"	1 1/2"	770
AG 220	1396	1310	331	300	163	470	2 1/2"	1 1/2"	770
AG 260	1572	1310	381	350	187	470	2 1/2"	2"	800
AG 300	1748	1310	381	350	187	470	2 1/2"	2"	800
AG 340	1924	1310	381	350	187	470	2 1/2"	2"	800

2. Description

- Standard control panel** (see the instructions supplied with the control panel for description and operation).
- Safety box with reset button** : This box performs and monitors all the sequences required for igniting, operating and turning off the burner.
 - Type Landis & Gyr LGD 12.01 (see operating cycle on page 6).
- Main two-stage gas valve**
- Ignition valve**
- Ignition burner** : It is used to ignite the main burner, and is fitted with an ignition electrode and an ionisation sensor which checks if there is a flame.
- Sight hole for ignition burner**
- Ionising sensor of main burner** : It is designed to check if the main burner flame is on.
- Safety valve**
- Gas pressure sensitive switch** (min. pressure : 12.5 mbar).

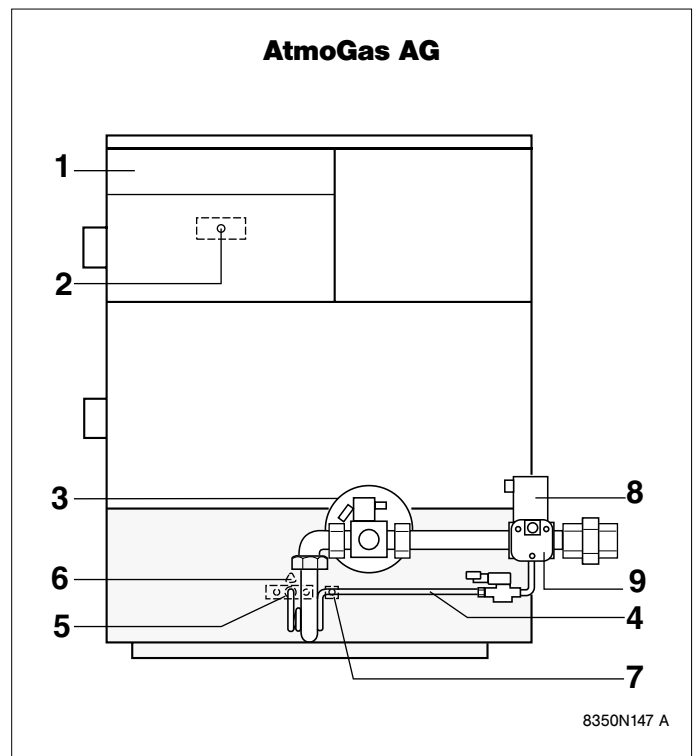

8350N147 A

Operation of boilers fitted with a LGD 12.01 safety box.

Operating principle :

The boiler can operate in the 2nd or 1st stage, depending upon the needs of the installation in terms of heat.

The burner ignition and monitoring cycle is performed by the safety box.

The main burner is ignited by an ignition burner which remains on during the operation of the main burner (1st or 2nd stage).

The ignition burner is turned on after a waiting time t_w . As soon as the flame is detected within time t_s which may not exceed 10 seconds, and after time t_4 , the main burner starts up and operates in the first stage (or the 2nd stage, depending upon the requirement of the 2nd stage thermostat).

Behaviour in the event of any malfunction :

- If the flame is not detected before the end of safety time t_s , the box safety device is set off and the red indicator on the control panel lights up and remains on until it is reset manually.
- If the flame is lost during normal operation, the box automatically repeats the start-up sequence.

Resetting :

To reset the box when its safety device has been set off, press the reset button on the external circuit. If this does not have the expected result, **wait for at least 15 seconds** before resetting once again.

Note 1 : The box may be in the safety position when it is started up for the first time. Press the reset button to release the safety device.

Note 2 : If the reset button is pressed during normal operation, the gas valves are closed, and the box starts up a new sequence.

- Normal operating cycle

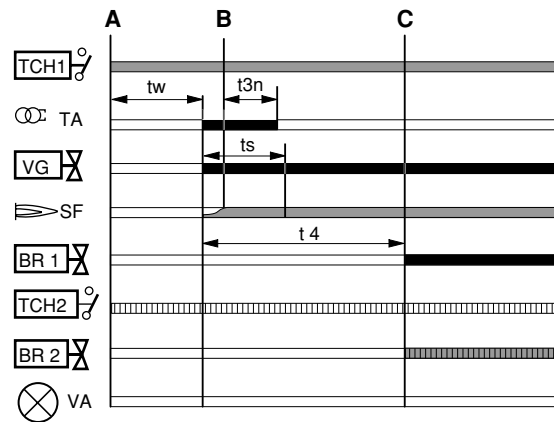

8350N012 B

- Operating cycle when the safety device is set off on starting up because there is no flame signal

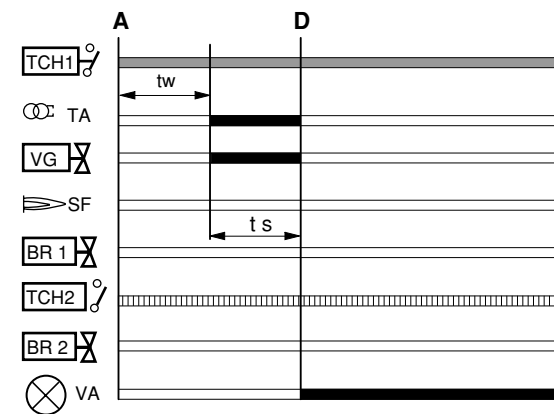

- Necessary input signal
- Output signal of safety box
- Call for heat 2nd stage
- 2nd stage operation

8350N013 B

- A** : Beginning of start-up operation
- B** : Formation of the flame at the ignition burner
- C** : Starting up of the main burner in the 2nd stage
- D** : Safety device set off because there is no flame
- TCH1** : 1st stage boiler thermostat
- TA** : Ignition transformer
- VG** : Ignition valve
- SF** : Flame signal from ignition burner
- BR1** : 1st stage
- TCH2** : 2nd stage boiler thermostat
- BR2** : 2nd stage
- VA** : Alarm indicator. The safety device has been set off
- tw** : Waiting time and pre-ignition time (1.5 sec.).
- t3n** : Post-ignition time (max. 2 sec.)
- t4** : Time between the opening of the ignition valve and the main valve (VG - BR1). (2 sec.)
- ts** : Safety time, max. 10 seconds.

3. Installing and connecting the boiler

3.1 Boiler location

- The figures indicate the minimum recommended dimensions for providing easy access around the boiler.
- Leave clearance equal to dimensions **a** and **b** for assembly tools (simplified JD tools for boilers with 8 - 14 sections, or JD-TE tools for boilers with 8 - 18 sections) :
 - if a = 500 mm ; b = 1800 mm
 - if a = 1800 mm ; b = 500 mm

The boiler should be positioned on a fireproof base which is level and flat.

Remark : Please note that boilers installed in or close to rooms in which the atmosphere is polluted with chlorine or fluorine compounds may be subject to high corrosion.

For example : hairdressing salons, industrial premises (solvents), cooling equipment, etc.

Boilers installed in such locations shall not be covered by the guarantee.

Boiler dimensions in mm.

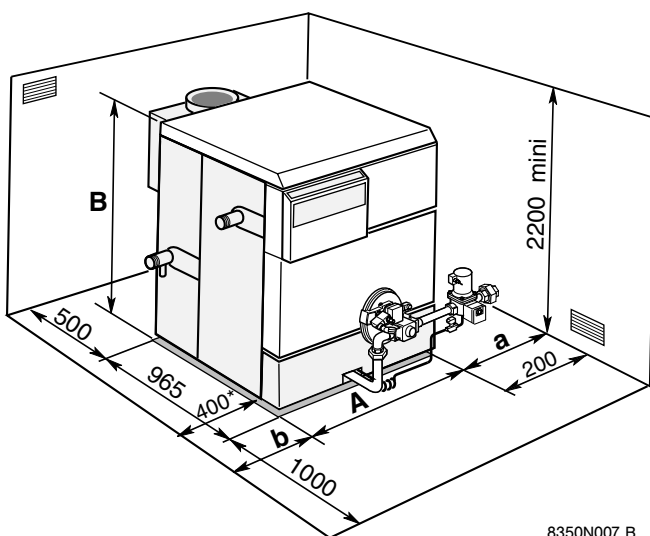

8350N007 B

§ Side of the water tapping

AtmoGas AG		140	160	180	200	220	260	300	340
A	mm	1044	1132	1220	1308	1396	1572	1748	1924
B	mm	1210	1210	1210	1310	1310	1310	1310	1310

Boilerhouse Ventilation

Detailed recommendations for air supply are given in BS6644.

The permanent ventilation of the boilerhouse (not including doors and windows which may be closed) is essential.

Boilerhouse ventilation serves two essential purposes. One is to permit combustion air to flow freely to the burners from outside the building and the second is to maintain a clean atmosphere within the boilerhouse at a reasonable temperature level.

Heat released from the boiler, the piping and the flue should not increase the boilerhouse temperature above 30°C.

Air Inlet requirements

It is essential that fixed air openings are provided at high and low level adjacent to the boiler front. Free inlet area of louvres required for ventilation and combustion air should not be less than 1200 mm²/kW rating (55 in m² per therm) (1 m² per 800kW boiler rating). The inlet opening should be at low level with a further ventilation opening of half that area at high level.

Air inlets and ventilation outlets are best disposed at low level and high level respectively, so that air convection across the boilers will create the necessary air changes. Preferably the high level opening should not be too close to the low level opening that short circuiting of air, without ventilation across the boilers, can occur. Where louvres are utilised in the boilerhouse door, louvres over the full door height are satisfactory.

For boilerhouses below ground level, arrangements should be made to induce fresh air into the boilerhouse where a natural flow of air is restricted by the buoyancy of air leaving higher level openings.

Any mechanical means of entering air into a basement boilerhouse should have a balancing outlet so that the air pressure in the boilerhouse does not exceed 0.05" W.G. (12.5 Pa).

The air supply requirements stated above are based upon the rated output of the boiler(s).

Air supply by Mechanical Ventilation

The supply of air into a space housing the boiler by mechanical means should be mechanical inlet with

natural or mechanical extraction. Mechanical extract ventilation with natural inlet must not be used.

Where a mechanical inlet and mechanical extract system is applied the design extraction rate should not exceed one third of the design inlet rate.

The requirements for air supply by mechanical ventilation are given in BS6644.

Note: For mechanical ventilation systems an automatic control should be provided to cut off the gas supply to the boiler(s) in the event of failure of air flow in either inlet or extract fans.

Draught diverter thermostat

A pre-set draught diverter thermostat is available as an optional item on AtmoGas AG 140-340 boilers.

The purpose of the thermostat is to shutdown the boiler(s) in the event of combustion products spillage.

Open Vented/Pressurised Systems

Open Vented Systems

A primary make up water and expansion tank is required for open vented systems. No special connection is provided at the boiler but it is recommended that the feed is connected into the heating return near the boiler.

The vent pipework should be taken above the primary make up and expansion tank.

The vent and safety valve connections should be made on the flow pipe close to the boiler before any other connections or valves are fitted.

Pressurised Systems

For independently pressurised systems a safety valve(s) should be provided and a connection for a test cock to check that water has filled the boiler.

The test cock should have a half circle copper pipe fitted to prevent water reaching the operator. When a pressurised system has been drained for repair etc, it is essential that the water level is checked (in each boiler in a multi-boiler system) to confirm that each one is full. This is essential as some systems, which are generally on a level below that of the boiler, may suffer from an air lock on refilling.

With a pressurised system, loss of water/loss of pres-

sure is monitored by a pressure switch supplied by the heating engineer and fitted at the boiler. This should be interlocked with the boilers control circuit to close the burner down if a fault occurs. Loss of pressure can allow boiling to occur in the higher levels of the system.

Water Treatment

There is basic need to treat water contained in all heating and indirect hot water systems, particularly open vented systems.

One millimetre of lime reduces the heat conversion from flame via metal to water by 10 %.

In practice the deposition of these salts is liable cause noises from the boiler body or even premature boiler failure.

Corrosion and the formation of black iron oxide sludge will ultimately result in premature radiator failure.

Open vented systems are not completely sealed off from the atmosphere as it is essential to provide a tank open to atmosphere if proper venting and expansion of system water is to be achieved. The same tank is used to fill the water and it is through the cold feed pipe that system water expands into the tank when the boiler passes heat into the system.

Conversely when the system cools, water previously expanded is drawn back from the tank into the system together with a quantity of dissolved oxygen.

Even if leakage from the heating and hot water systems is eliminated there will be evaporation losses from the surface of the tank which, depending on ambient temperature, may be high enough to evaporate a large portion of the system water capacity over a full heating session.

There will always be corrosion within a heating hot water system to a greater or lesser degree irrespective of water characteristics unless the initial fill water from the mains is treated. Even the water in closed systems will promote corrosion unless treated.

For these reasons, Hoval recommend strongly that when necessary the system be thoroughly cleaned prior to use of a stable inhibitor, which does not require continual topping up to combat the effects of hardness salts and corrosion on the heat exchangers of Hoval AtmoGas AG boilers together with their associated systems.

Hoval advise contact directly with major specialists on water treatment such as Grace Dearborn or Houseman.

3.2 Gas connections

Gas connections shall be in compliance with applicable regulations and standards.

In all events, a shut-off valve shall be located as close to the boiler as possible.

Class	I 2H
Gas type	G20
Distribution pressure (mbar)	20

3.3 Flues and Chimneys



Guidance for sizing flues and chimneys is given in CIBSE and HVCA guides and also Hoval Technical Data Sheets.

General Guidelines

- Individual chimneys and flues should be used whenever possible for multi-boiler plants so that combustion conditions are not disturbed by the operation of other boilers.
- Use of short runs of flues and with the minimum of large radius bends without horizontal runs before entering the main chimney at 45° are recommended and will cause the least resistance.
- Flues should not be less in diameter than the boiler outlet connection size.
- In deciding the flue run, the chimney height buoyancy should provide a negative pressure condition at the boiler flue outlet.

- If two flues must enter into one common stack they should be positioned to cause the least disturbance to the other gas stream (i.e. not opposite to each other).
- Where flues from two or more boilers join the header the gas streams should be flowing in the same direction at the point of intersection with the header.
- Header cross sectional areas should take account of the quantity of gas flowing at each intersection. Allow for condensation points in chimney and flue. Condensation should be drained at the base of the vertical run. Horizontal runs should drain away from the boiler.
- Steps should be taken in designing to prevent or minimise condensation forming by using double skin and/or insulated flue systems and suitably insulated brick stack or double skin steel chimney. This helps prevent condensation.
- There should be a removable flue section above the down draught diverter to allow for diverter removal.
- Chimney outlets should not be restrictive and low loss terminals should be used.
- Flues should be supported independently to prevent undue weight and forces due to expansion being transmitted to the boiler outlet connection.
- Adequate doors should be provided in flues and chimneys for cleaning and inspection purposes. Square tees must not be used for creating a drain point at a flue change of direction as this creates difficulties in firing the burner.
- Specialist flues are available for difficult situations such as a low level flue adjacent to a tall building. In this case a vertical balanced flue can be helpful. Refer to Hoval for further details.

Chimney sizes and height will need to take into account the following :

1. Clean Air Act.
2. Local Regulations.
3. Environmental Protection Act 1990.
4. Considerations to adjacent buildings.
5. Flue gases discharged to the atmosphere which contribute to health dangers should be minimised by maintaining the burner and boiler to ensure correct combustion and high efficiency to reduce running time to a minimum and to maintain low levels of CO₂ (Greenhouse effect) ; CO and NO_x (dangerous gases). Current regulations for NO_x limits (1993) are maximum 260 mg/kWh (148 p.p.m at 0% O₂). Burners supplied with Hoval boilers fully meet this requirement.
6. When an AtmoGas AG boiler is required to operate at a low return temperature, say 40°C, then the flue gas temperature will be low and the flue materials should be watertight and insulated accordingly, with drainage away from the boiler.

3.4 Hydraulic connections

When the boiler is connected to an existing central heating system, the entire system must be rinsed thoroughly in order to ensure that no sludge is introduced into the heating element of the boiler. The use of a sludge trap (strainer) on the boiler return is also recommended.

- G** Drain
- H** Threaded water flow tapping
- I** Threaded water return tapping

Connections **H** and **I** may be made on the right or left-hand side of the boiler. **However both connections should always be on the same side.**

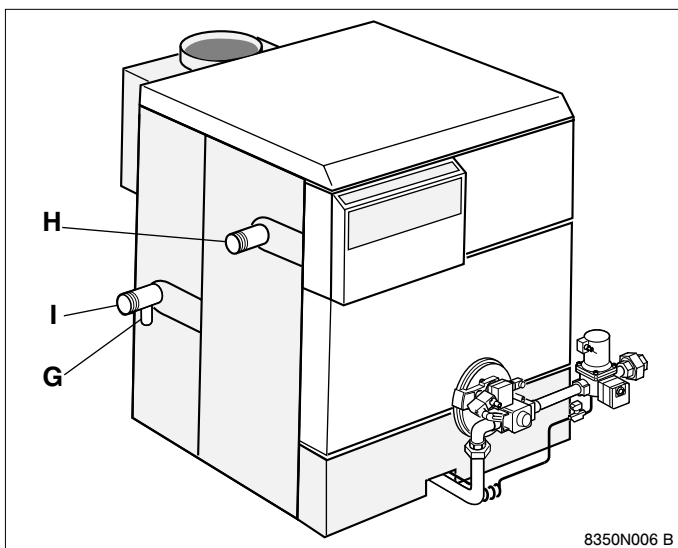

3.5 Filling the system



Recommendation
It is recommended that each system should be filled or refilled with treated water and specialist firms will be able to advise in this respect.

Check the following :

- all connections are made and tightened
- instrument pockets are fitted and water tight
- spare sockets are fitted with plugs and are water tight
- all valves in the heating circuit are open
- mixing or diverting valves are opened half way, then gradually fill with water until the altitude gauge (if fitted) indicates the correct head and the header tank is filled to appropriate level

- the installation is completely vented
- if a pressurisation unit is installed reference should be made to the makers filling instructions and applied
- installation debris and any deposits from the system are not allowed into the boiler
- the boiler is flushed out through the drain connection to ensure that the boiler is clean inside
- a large strainer is fitted to older systems to remove deposits before the return enters the boiler.

Important

The complete filling and draining down of the heating circuit must be carried out by the Heating Engineer prior to commissioning. Hoval will commission if requested.

Water Flow & Return Temperatures

Consideration will already have been given to the system flow and return temperatures but please note :

1. The flow temperature can be adjusted to within the limit of 90°C given previously on page 4.
2. The return temperatures should be controlled to be not less than 30°C. For lower V.T. circuits a diverting valve should be used.
3. Differentials between the flow and return should not exceed 20K.

Danger of Frost

If the heating process is stopped for a relatively long period of time in winter, the entire heating system including the boiler must be emptied completely. While doing so, the discharge valve should be checked for dirt. The discharge valve at the boiler should remain open until the system is refilled.

4. Setting the pressure at the injection nozzles to adapt the boiler power

- Do not start up the boiler without making sure that the points given under paragraph 6.1 have been checked.
- Connect the pressure gauge to the manifold pressure tap.
- Start up the boiler and put the thermostat/s on the maximum position.
- Remove cap **A**
- **Setting the pressure of the 2nd stage :**
 - Operate the boiler in the 2nd stage by turning the thermostat/s.
 - Set the gas pressure in the range given in paragraph 5 by turning screw **B** with a 8 mm spanner. Pressure is increased when the screw is tightened, and decreased when the screw is loosened.
 - Start up the unit repeatedly and check the pressure.
- **Setting the pressure of the 1st stage :**
 - Disconnect 2nd stage connector **D**.
 - Set the 1st stage gas pressure at half the pressure of the 2nd stage set previously. To do this, turn adjusting screw **C** with a 3.5 mm screwdriver. Tighten the screw to increase pressure, and loosen it to decrease pressure.
Always make sure that the 1st stage injection pressure is half the 2nd stage pressure. In this way, 1st stage power will be equal to 70% that of 2nd stage.
 - Start up the boiler in the 1st stage several times to make sure that it starts up correctly.
 - Connect 2nd stage connector **D**.

Remark :

- Make sure that the settings are located within the ranges given in the table under section 5 (page 13).

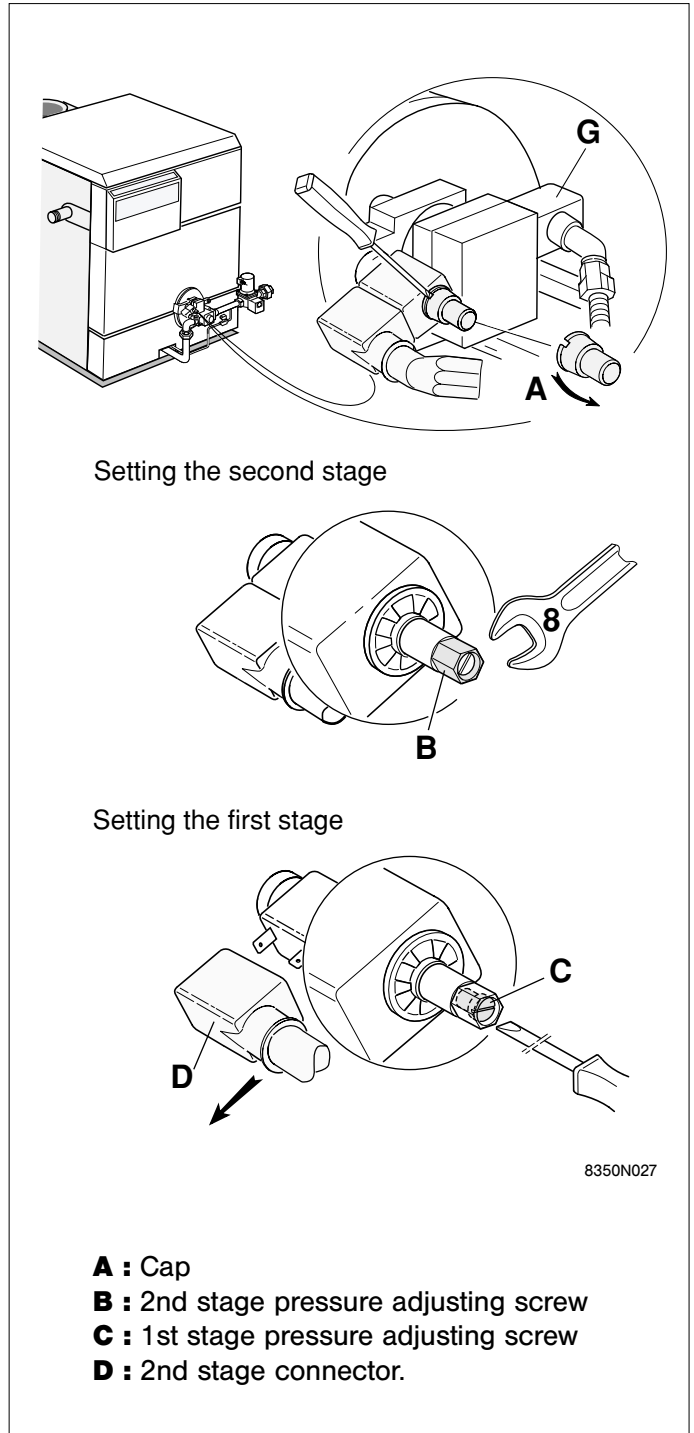

5. Setting pressures and calibrated injection nozzle markings

Pressure/flow rate and injection nozzle marking table - 15°C - 1013 mbar

Type of boiler			AG 140	AG 160	AG 180	AG 200	AG 220	AG 260	AG 300	AG 340
Output power	2nd stage	kW	119 to 140 (1)	136 to 160 (1)	153 to 180 (1)	170 to 200 (1)	187 to 220 (1)	221 to 260 (1)	255 to 300 (1)	289 to 340 (1)
	1st stage	kW	83.5 to 98 (1)	95 to 112 (1)	107 to 126 (1)	119 to 140 (1)	131 to 154 (1)	155 to 182 (1)	179.5 to 210 (1)	202.5 238 (1)
Input power	2nd stage	kW	133.7 to 156.1	153.3 to 179	171.3 to 200	190.2 to 222	208.9 to 243.9	247.5 to 288.9	183.6 to 331.1	322.2 to 376.1
	1st stage	kW	95.2 to 111	108.7 to 127.4	121.6 to 142.4	135.1 to 158	148.5 to 173.6	176.1 to 205.6	201.5 to 235.7	229.1 to 267.7
Natural gas flow rate (G20)		m ³ /h	14.15 to 16.52	16.22 to 18.94	18.13 to 21.16	20.13 to 23.49	22.1 to 25.81	26.19 to 30.57	30.01 to 35.04	34.05 to 39.80
Pressure at natural gas nozzles	2nd stage	mm CE	117 to 160	117 to 160	117 to 160	117 to 160	117 to 160	117 to 160	117 to 160	117 to 160
	1st stage	mm CE	1st stage pressure = 0.5 x set 2nd stage pressure							
ø of main burner nozzles for Natural gas		mm	3.9	3.9	3.9	3.9	3.9	3.9	3.9	3.9
ø of ignition burner nozzle Natural gas		mm	0.75	0.75	0.75	0.75	0.75	0.75	0.75	0.75

(1) Factory setting

6. Commissioning

6.1 Checks required before starting up the boiler

It is essential that the following points are completed by the Heating Engineer before commissioning is requested through Hoval.

- **System full of water and vented**
- **Heating load available e.g. pumps working**
- **Fuel purged to burner isolation valve**
- **The gas supply pressure is correct**
- **Electrical connections made and correctly fused**
- **Correct boilerhouse ventilation**
- **Other manufacturer's equipment has been installed & commissioned as necessary, e.g. pressurisation units.**

If the above are not completed and commissioning is unable to commence, clients will be charged for the abortive visit.

When a Hoval Engineer is engaged to commission the boiler the following items are checked (if another qualified service company carries out the commissioning the same checks should be made).

- the boiler and system is filled with water and vented, including circulation pumps.
- an independently pressurised system is operating correctly. Suppliers of the equipment should adjust their equipment during commissioning.
- the electrical installation with the appropriate wiring diagram.
- the gas line is purged.
- the burner assembly is correctly located and that it has suitable nozzles for the fuel available at site (e.g. Natural Gas).

- the boiler relief valve setting is suitable for the system (The setting should be at least 0.5 bar above the system pressure).
- the Heating Engineer will have the opportunity to receive instruction on the correct operation of the plant during commissioning.

6.2 Starting up

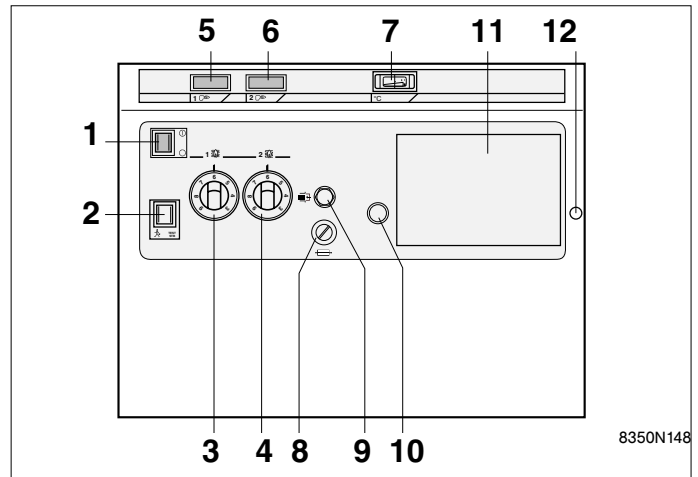

1. On/Off switch with indicator : It is used to cut off power supply to the boiler. "Ⓢ" is the On position and "ⓐ" is the Off position.

2. Three-position switch :

- **Test STB** position: It is used to test the safety limit thermostat.
- **Middle** position : It is selected when the boiler is fitted with an optional TopTronic controller.
- **Hand operation** ⚠ : it must be selected when the boiler is not fitted with a TopTronic controller. When the boiler is fitted with a TopTronic controller, this position may be used to test the burner. The burner is forced to operate regardless of the settings of the control unit.

3-4. Boiler thermostats. These have an adjustment range of 40 - 85° C, and determine if the boiler is required to operate in the 1st or 2nd stage.

The set value of the 1st stage thermostat (**ref. 3**), must always be about 5° C higher than that of the 2nd stage thermostat (**ref. 4**).

If the boiler is fitted with a TopTronic controller the thermostat/s must be put on the maximum position.

5. 1st stage operation indicator.

6. 2nd stage operation indicator.

7. Boiler thermometer.

8. 3.15 Amp. Fuse. It is accessible from the boiler control panel, and is designed to protect the burner control circuit.

9. Safety thermostat (100° C) with manual reset :

It is fitted on the supply circuit. It cuts off the gas supply in the event of overheating. The boiler can only be started up manually, after the cause of the overheating has been corrected.

To reset the thermostat, remove cap 11 and press the reset button with a screwdriver.

10. Safety box reset button: The safety box performs and monitors all the sequences required for igniting, operating and turning off the burner. Type LANDIS & GYR LGD 12.01.

11. Location for optional TopTronic controller.

12. Panel closing screw.

- Open the main gas shut-off valve.
- Check the position of three-position switch **3** :
 - **Middle** position : This position is used when the boiler is fitted with an optional TopTronic controller.
 - **Hand operation**  position : This position must be selected when the boiler is not fitted with an optional TopTronic controller.
- Make sure that safety thermostat **11** has been activated. To reset the thermostat, unscrew the hexagonal cap and press the reset button with a screwdriver.
- Position the regulation devices (thermostats **4** and **5**, weather compensator) so that heating is required.

IMPORTANT : The set value of 1st stage thermostat 4 must always be about 5°C higher than that of 2nd stage thermostat 5.

- If the boiler is fitted with an optional TopTronic controller or is part of an installation with several boilers in cascade, thermostat/s 4 and 5 should be set on the maximum position.

- Put On/Off switch **1** on the On  position.
- The ignition burner will light up, followed by the main burner (1st and 2nd stage).

7. Fitting a TopTronic controller

The control panel may be fitted with an optional TopTronic controller.

The optional units are easily assembled in the housing designed for this purpose on the control panel.

1. Give the panel closing screw a quarter turn with a screwdriver to open the control panel.

2. Use a screwdriver to remove the cover held in place by two self tapping screws.

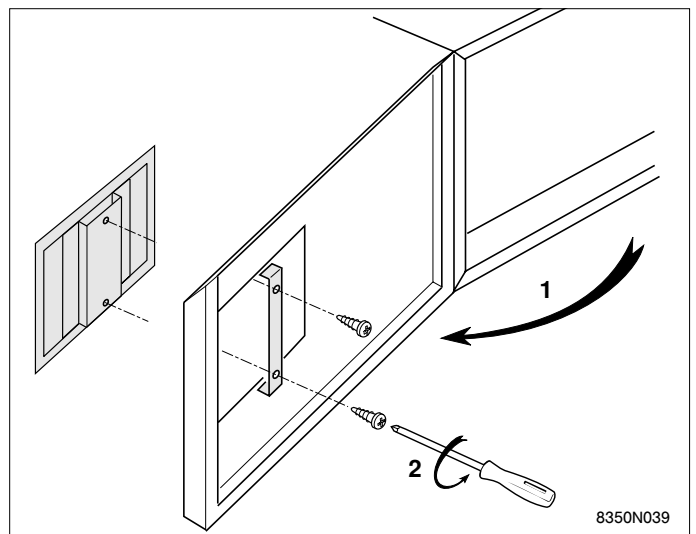

3- Fit the box in from the front, and fasten it with the two screws located on the front of the unit (1/4 turn, clockwise).

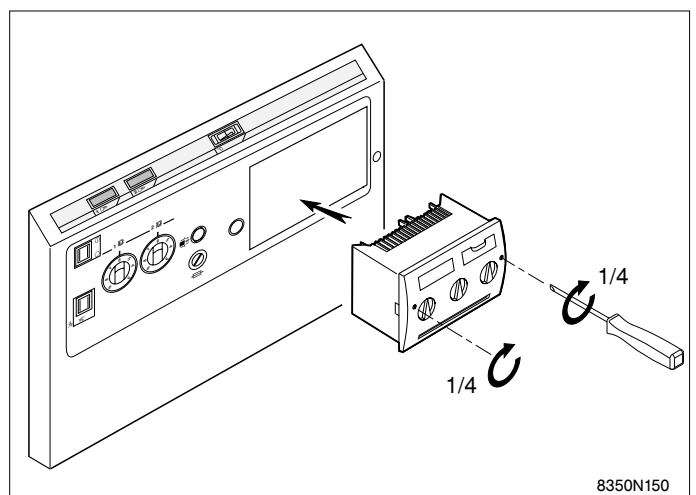

4- Fitting the TopTronic controller :

Plug in the four connectors to the rear of the TopTronic Controller.

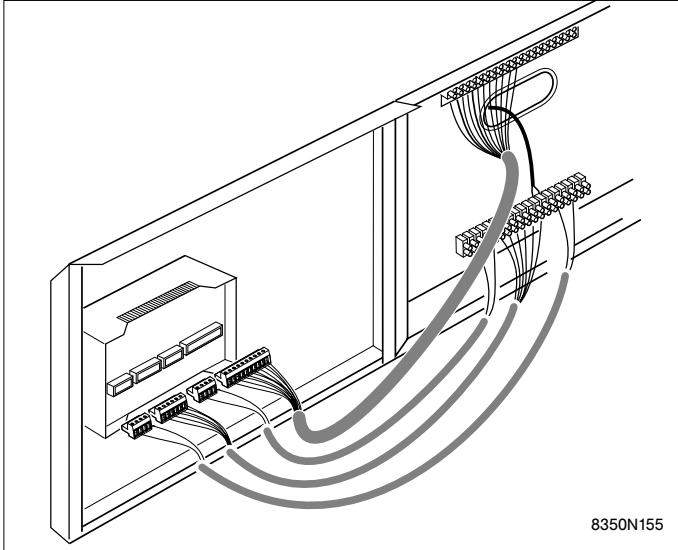

5- Installing the sensor :

Fit the bulb of the boiler sensor into the boiler finger aperture.

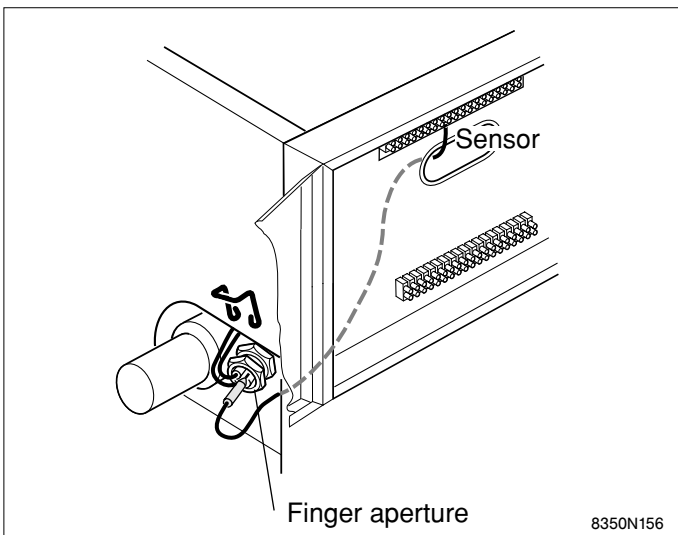

8. Electrical connections

Important : Electrical connections should be carried out by a qualified professional only.

Connecting to the mains

The connection to the mains must comply with applicable standards and regulations.

An isolating transformer (available as an option) is required if the electrical system does not have a neutral conductor or if the neutral conductor is not directly connected to the earth. This is required for the correct operation of the ionising flame sensor.

The wiring has been carefully checked in the factory. Never modify the internal wiring of the control panel.

Electrical connections must be made in compliance with applicable standards and regulations, and as per the instructions given in the electrical diagrams supplied with the units and the guidelines below.

Note : In order to avoid interference, separate the sensor cables from the other circuits. Proceed as follows :

- **In the boiler : Use the two cable channels on either side of the boiler. Place the 230 V cables in the left-hand channel and the sensor cables in the right-hand channel.**
- **Outside the boiler, use two ducts or cable channels which are at least 10 cm away from each other.**

● Connection under the control panel

Check if the following connectors are in place under the control panel.

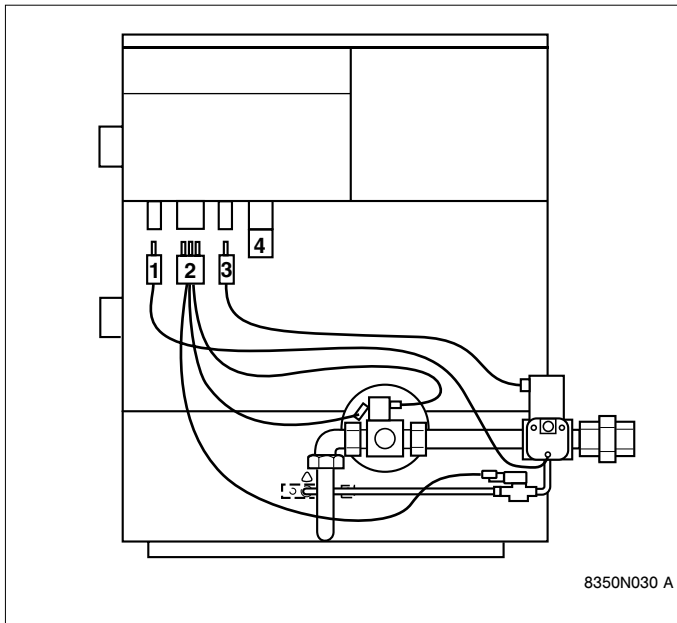

1. Gas pressure sensitive switch (min.)
2. 1st and 2nd stage gas valve
3. Safety gas valve
4. Gas valve proving kit (optional) or bridge plug

Important :

The bridge plug is located inside the control panel for safekeeping and need to be fitted as above for correct operation of the boiler.

To open the panel, give the panel closing screw a quarter turn with a screwdriver.

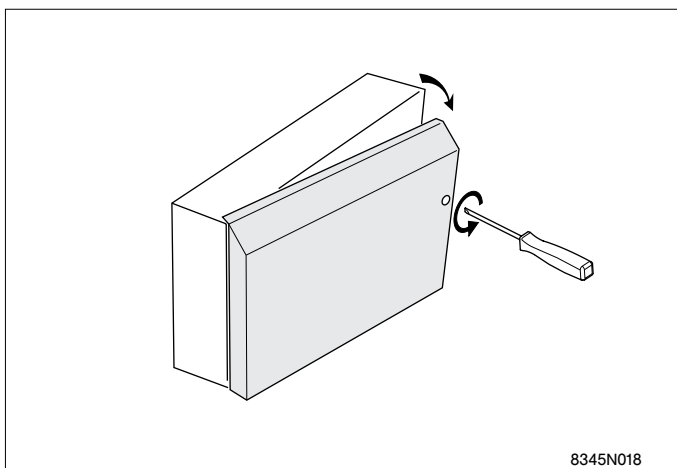

● Connecting to the strips

Make the electrical connections to the two marked horizontal strips located inside the control panel.

- Pull the connecting cables into the boiler through the cable gland designed for this purpose on the top rear panels, and place them in the cable ways located along the side panels.

- Pass the cables through the opening in the rear panel box, and connect them to the terminals as instructed below.

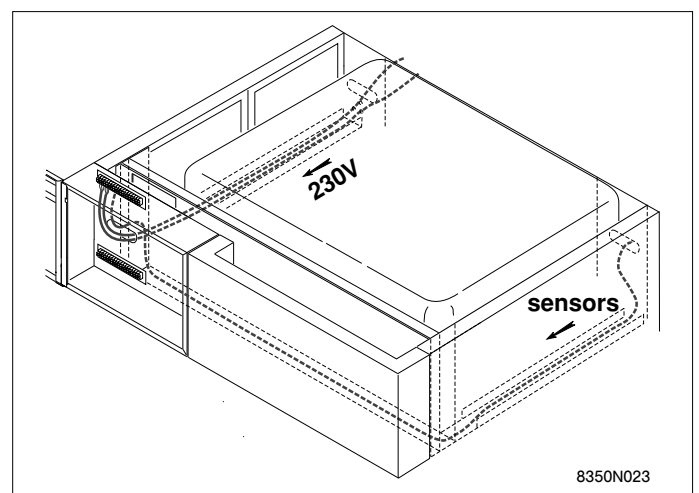

Standard electrical diagram for AG 140-340 boilers

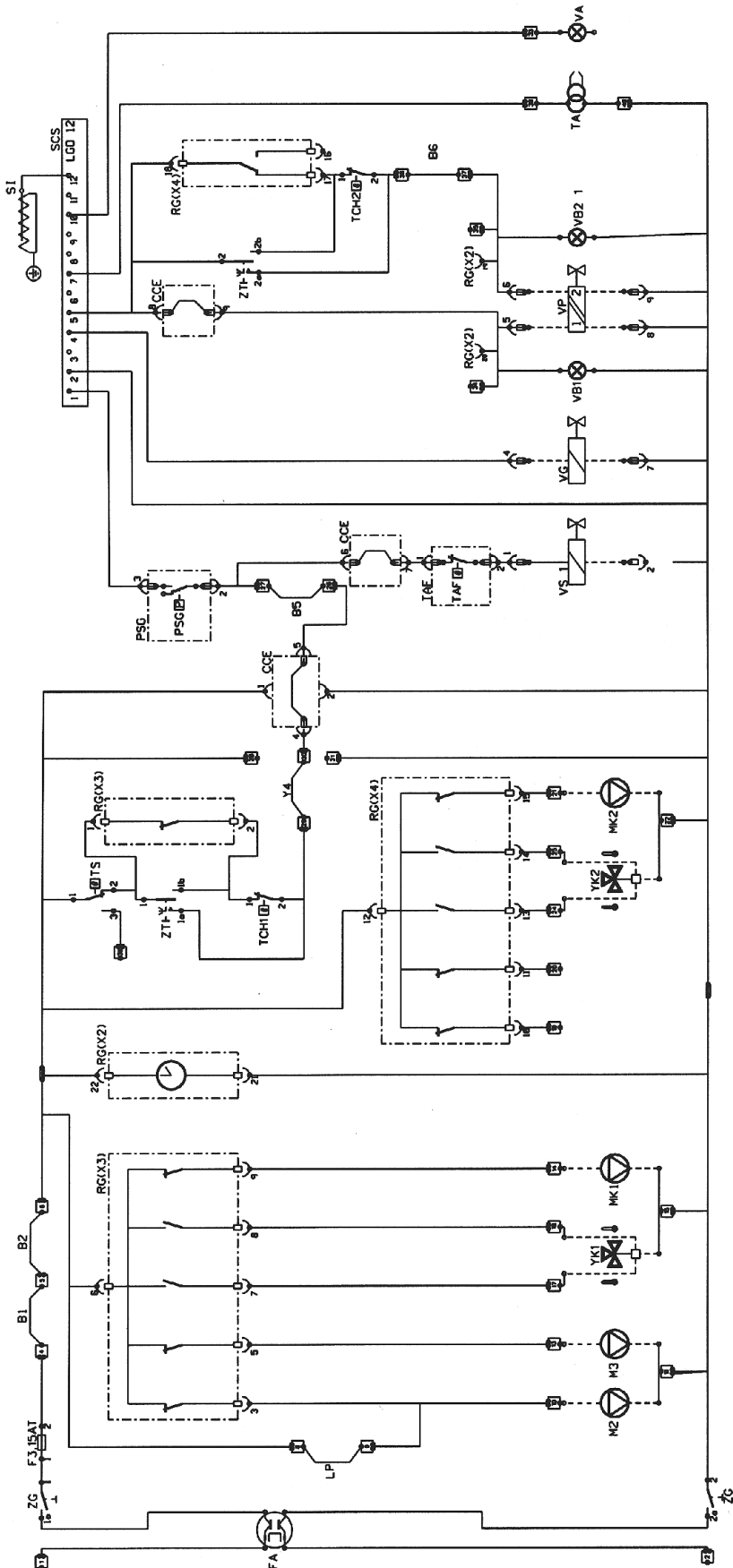

- | | | | |
|------------------|-----------------------------|------------|------------------------|
| B | Burner connector | VB2 | Burner run 2nd stage |
| B1 | Safety interlock | VG | Gas valve |
| B2 | Spare | VP | Main gas valve |
| B5 | Remote On/Off | VS | Safety gas valve |
| B6 | Remote High/Low | Y4 | Flue damper |
| BA1 | Connecting board | YK1 | Valve mixing circuit 1 |
| CCE | Leak proofing | YK2 | Valve mixing circuit 2 |
| F 3,15 AT | Fuse 3.15 A delayed | ZG | Main switch |
| FA | EMI suppressor | ZT | Test switch |
| L | Phase | | Earth |
| LP | Heating pump logic | | Connector |
| M2 | Heating pump | | |
| M3 | Calorifier | | |
| MK1 | Pump mixing circuit 1 | | |
| MK2 | Pump mixing circuit 2 | | |
| N | Neutral | | |
| PSG | Gas pressure switch | | |
| RG | Regulator connector | | |
| SCS | Safety control box | | |
| TA | Ignition transformer | | |
| TAF | Draught diverter thermostat | | |
| TCH1 | 1st stage boiler thermostat | | |
| TCH2 | 2nd stage boiler thermostat | | |
| TS | Safety thermostat | | |
| VA | Alarm indicator | | |
| VB1 | Burner run 1st stage | | |

8350N157
(8350-4381 C)

Note : For other (job-specific) wiring configurations, a separate wiring diagram will be issued with the boilers.

9. Maintenance

Clean the burner regularly for unit efficiency. Cleaning is recommended once a year.

9.1 Cleaning the burner

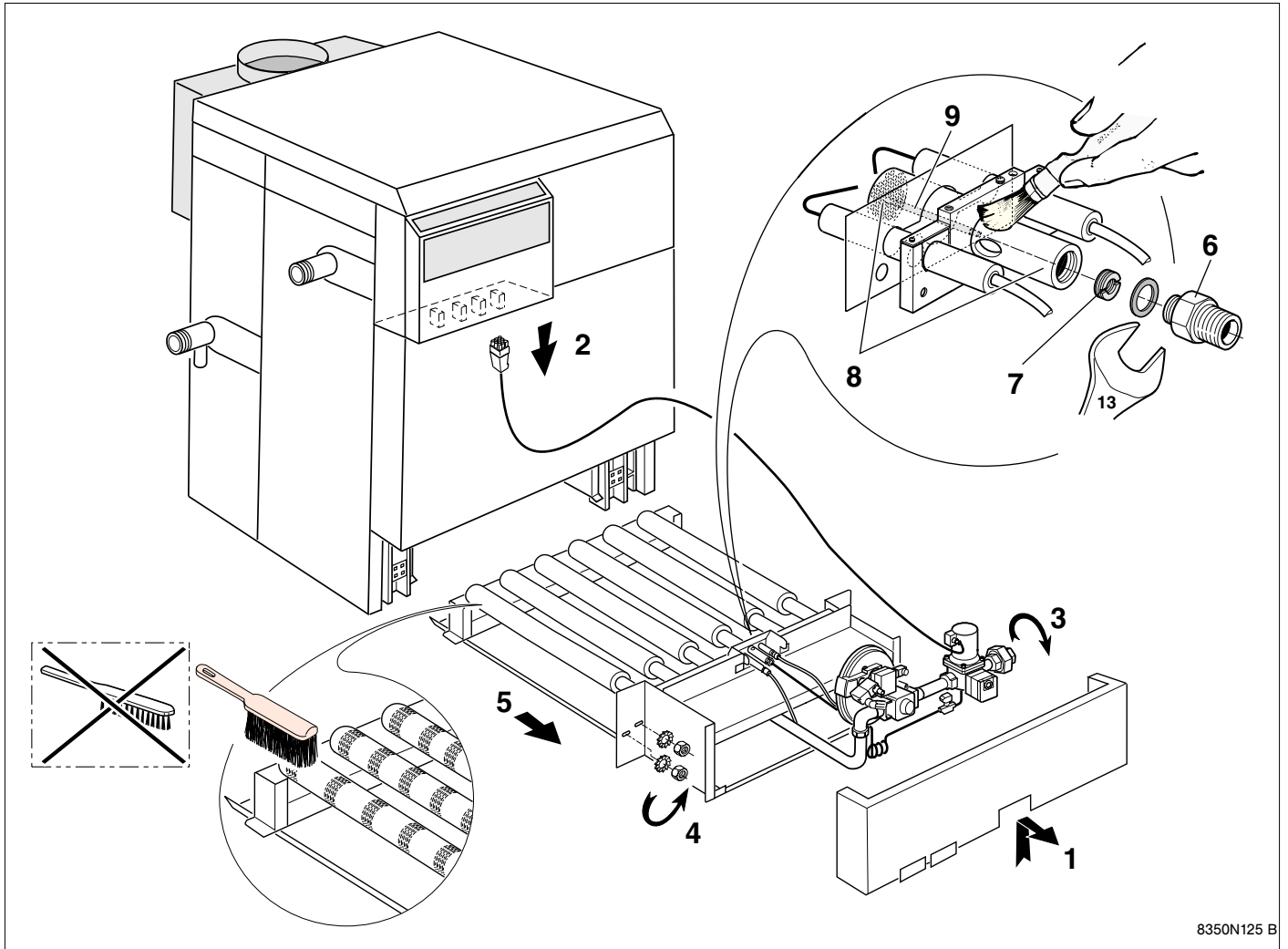

8350N125 B

Removing the burner :

- Cut off the power supply to the boiler.
- Cut off the gas supply.
- Remove lower boiler panel **1**.
- Disconnect single-piece valve connector **2** located under the control panel.
- Unscrew pipe union **3** on the gas inlet tube.
- Unscrew the four fastening screws **4** of the burner drawer.
- Remove burner tray **5**.

Cleaning the main burner and the ignition burner :

- Brush the burner rails with a soft brush or using a vacuum cleaner.
- Disconnect gas supply tube **6** from the ignition burner using a 13 mm spanner.
- Clean injection nozzle **7**, ignition burner **8** and flame stabilising tube **9**, located inside the ignition burner.

Do not use a metal brush !



- While reassembling the unit, make sure that the burner earthing wire has been fixed to the burner drawer fixing nut.
- After assembling the unit, check if the gas lines are tight.

9.2 Cleaning the heating sections

Check the condition of the heating sections once a year, and clean if dirty.

If the boiler conduits need to be swept, remove the burner drawer from the combustion chamber so that deposits and soot do not block the openings of the gas burner rail.

Once the burner has been removed as directed in section 9.1 :

- Remove the cover.
- Remove the top insulating material.
- Open the sweeping trap of the flue gas removal unit.
- If necessary, clean the boiler body with the special brush supplied.

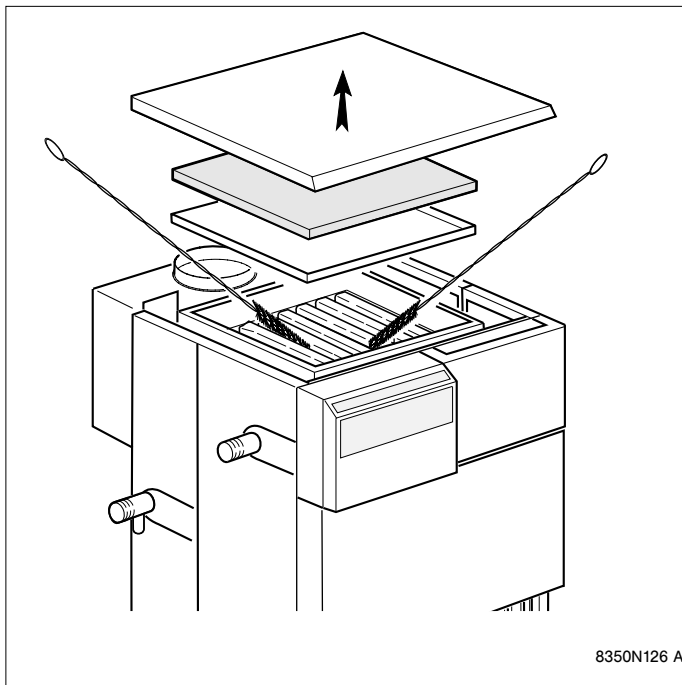

9.3 Painted surfaces

Painted surfaces may be cleaned with cold or lukewarm soapy water. Wipe with a soft cloth or a wet sponge.

9.4 Identification plate

The identification plate fixed on the gas line is used to identify the boiler correctly. It also provides the main specifications data for the boiler.

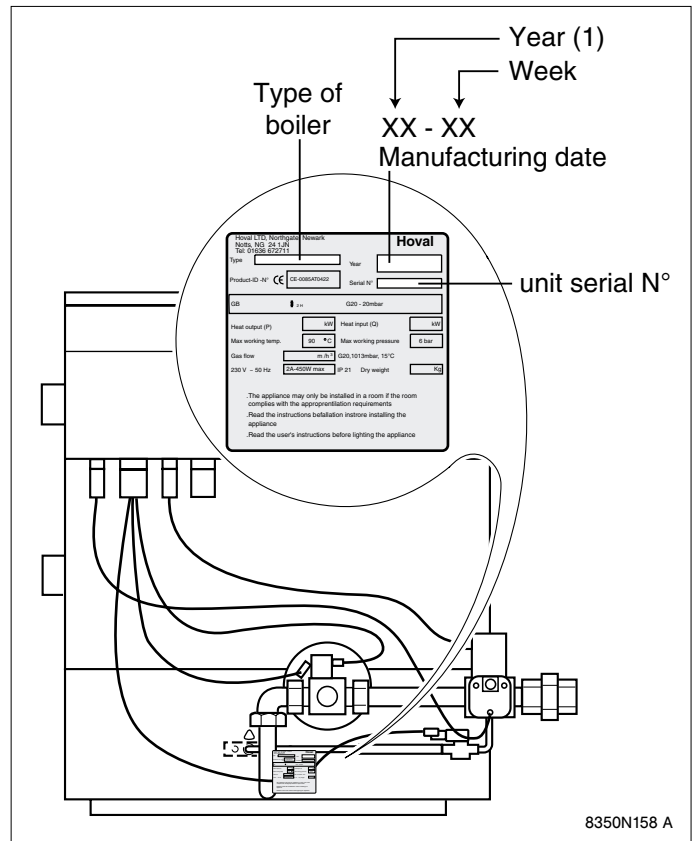

(1) 00 = 2000, 01 = 2001....

10 Exploded view and list of spare parts

Note : While ordering spares, do not forget to state the code number given opposite the description of the required part in the list.

- Boiler body

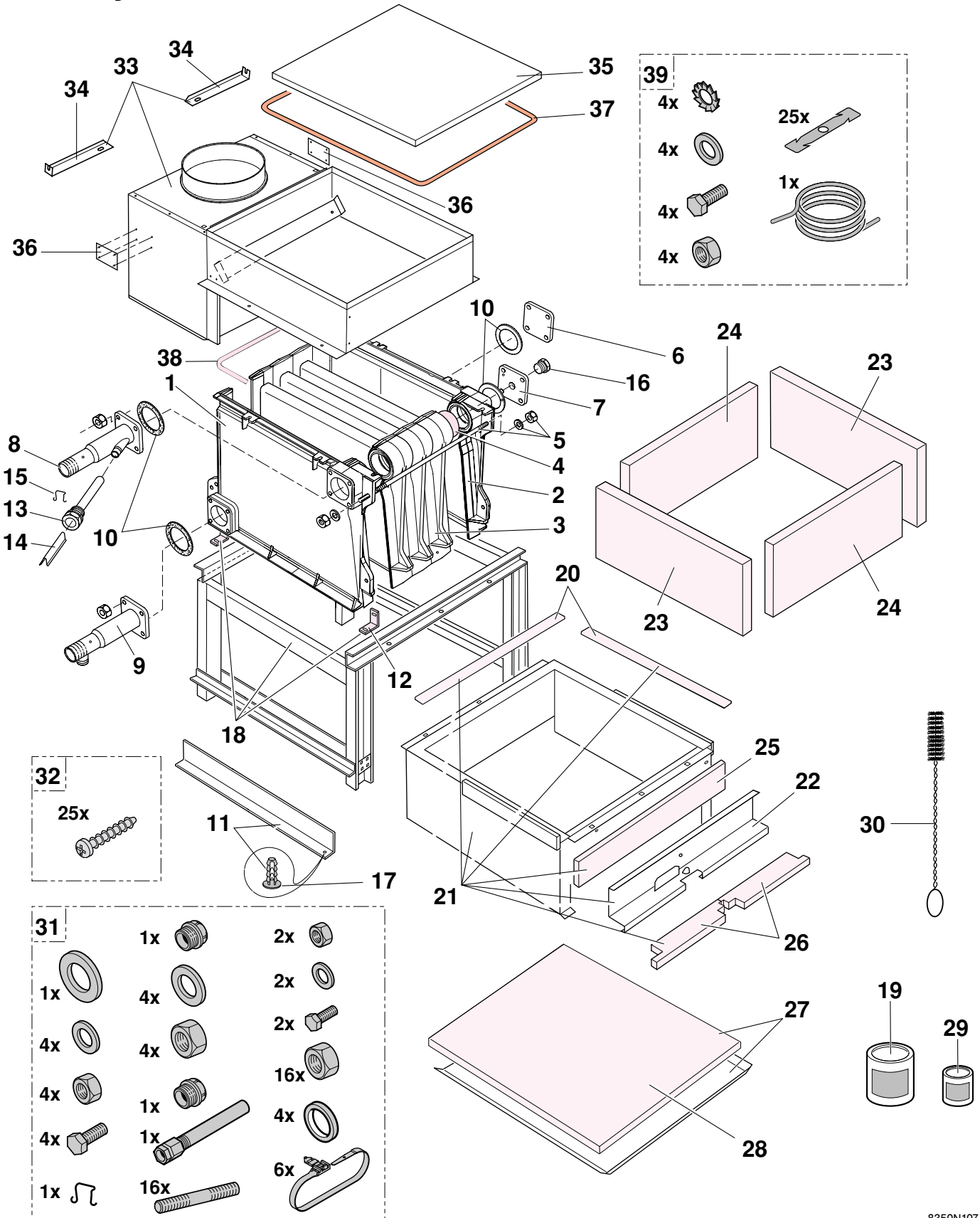

- Body insulation

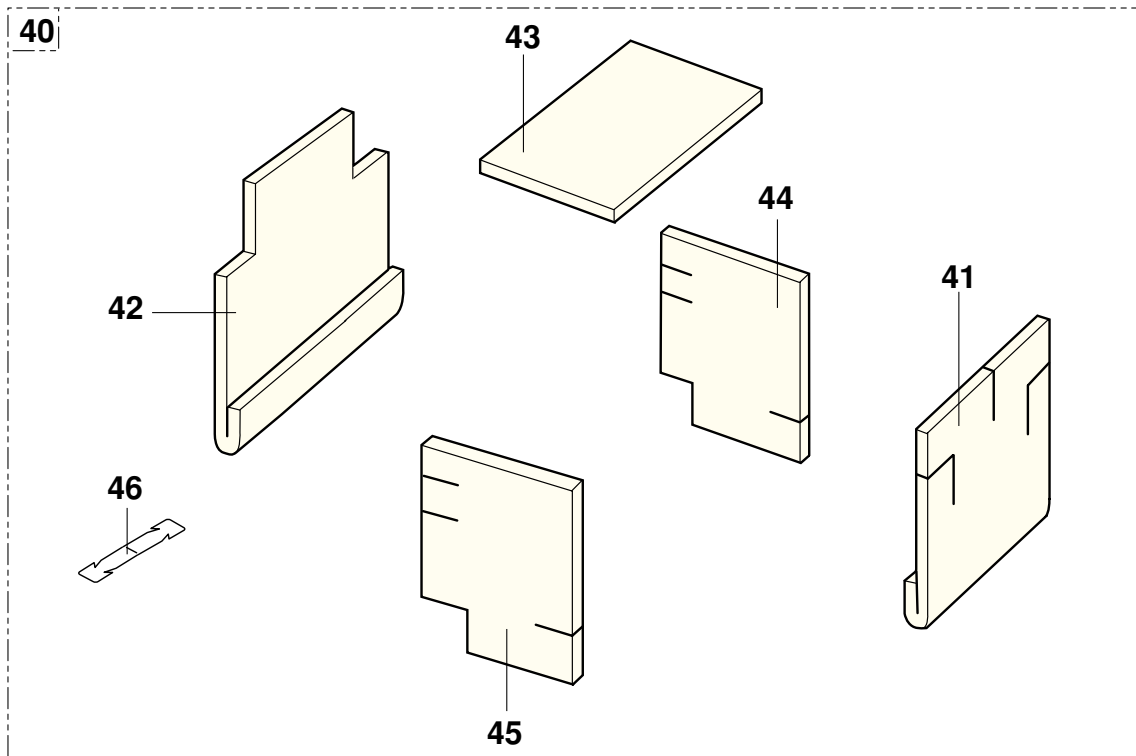

8350N113

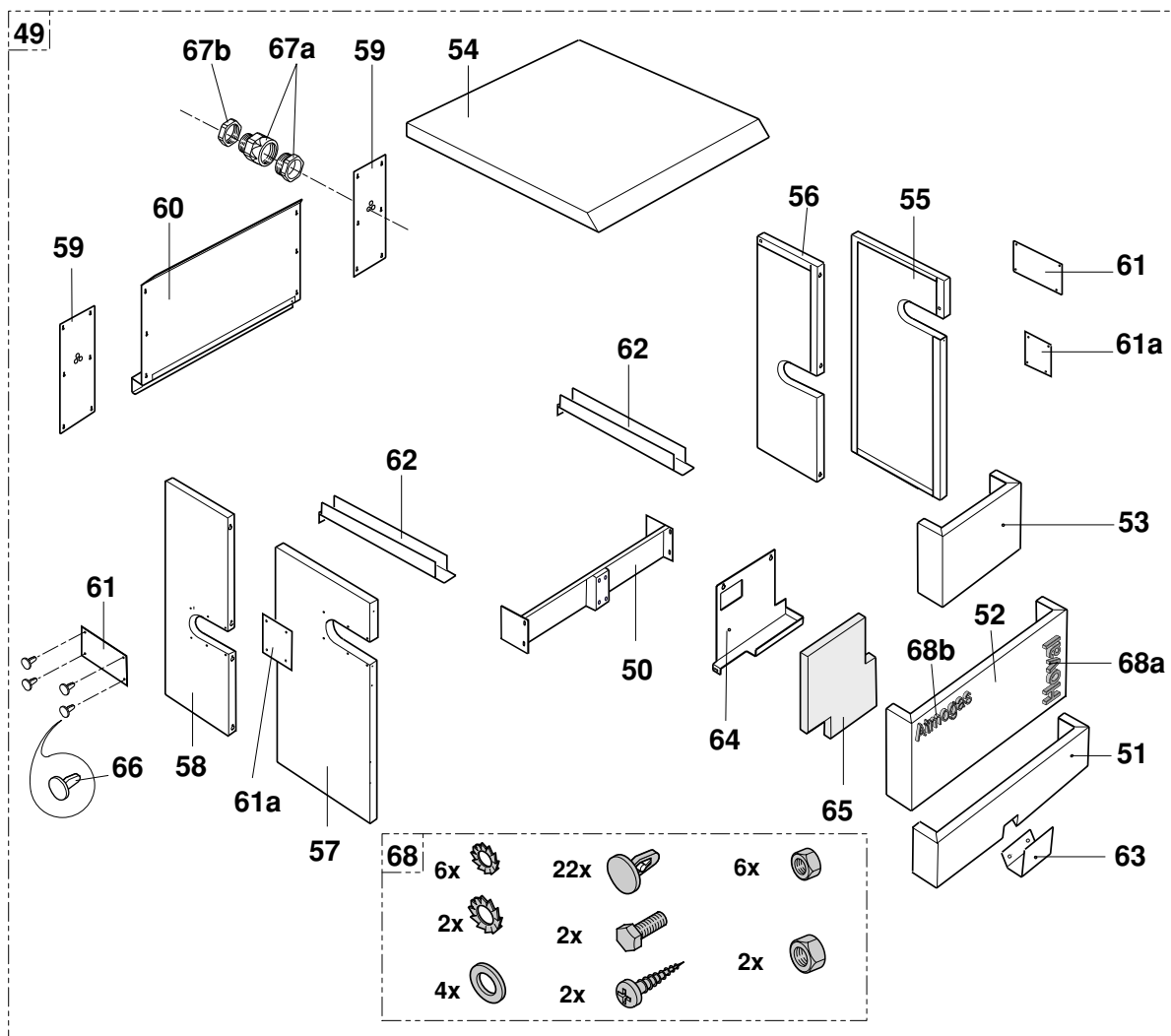

8350N154

- 20 mbar GAS LINE (before 10/2000)

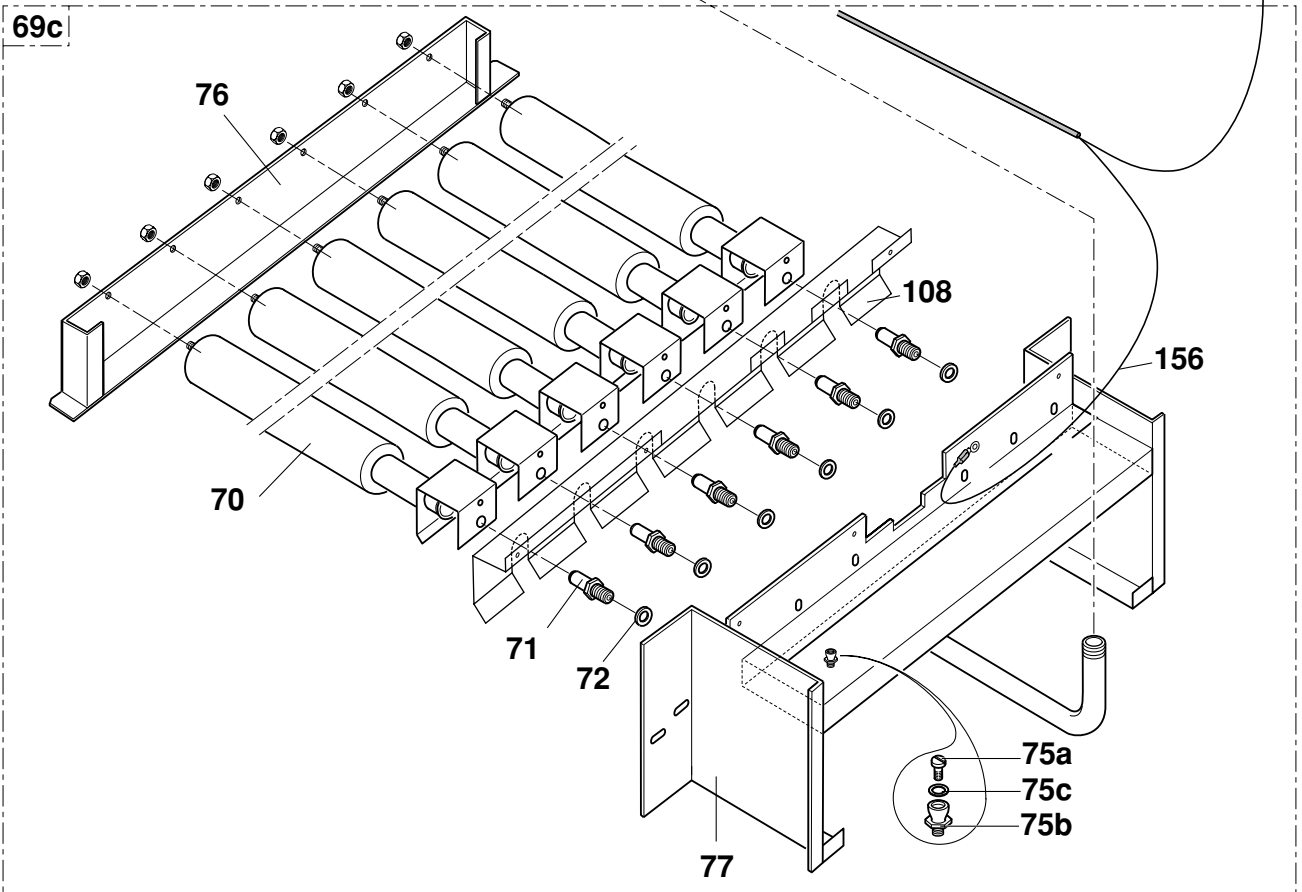
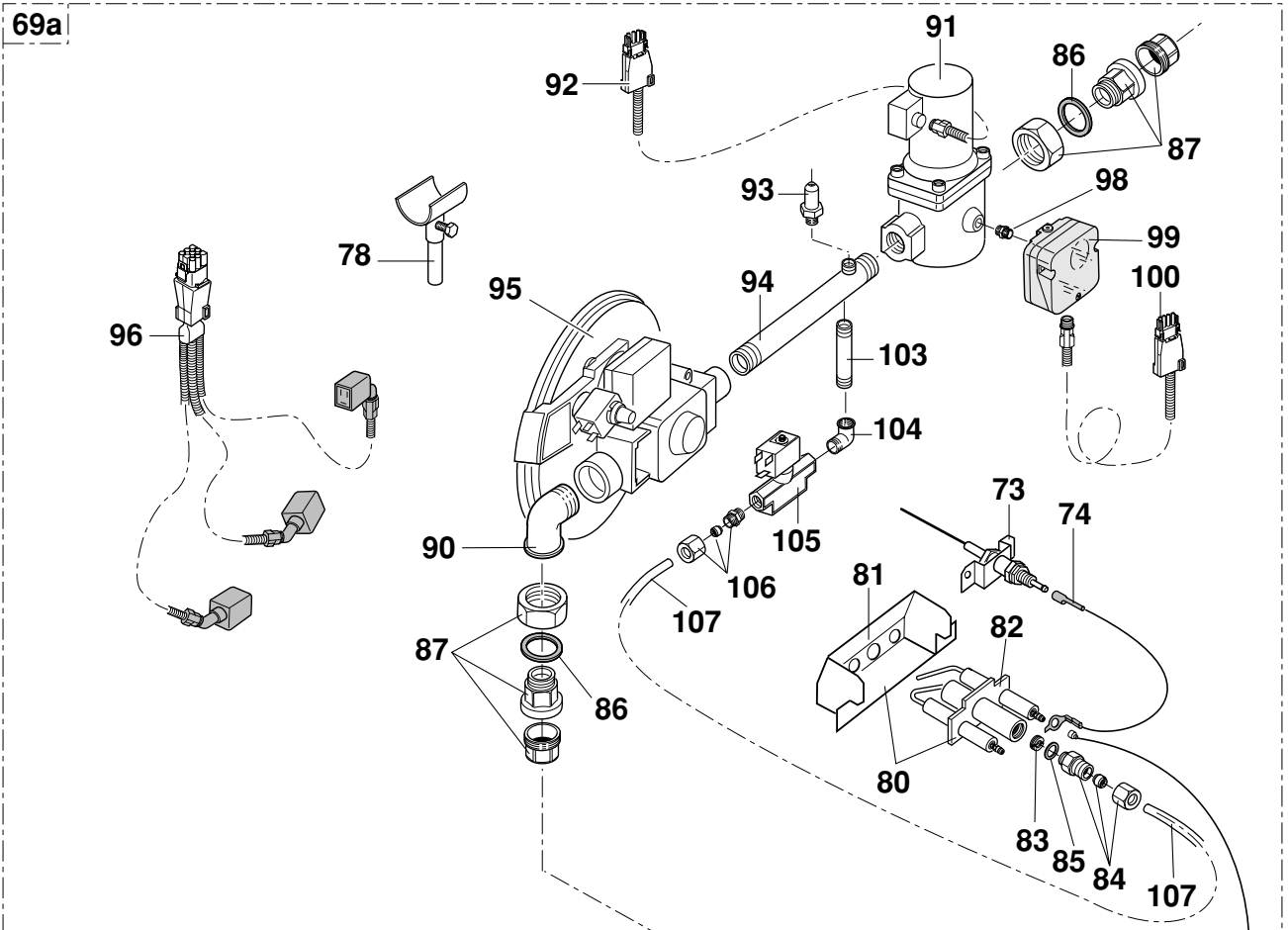

- 20 mbar GAS LINE (after 10/2000)

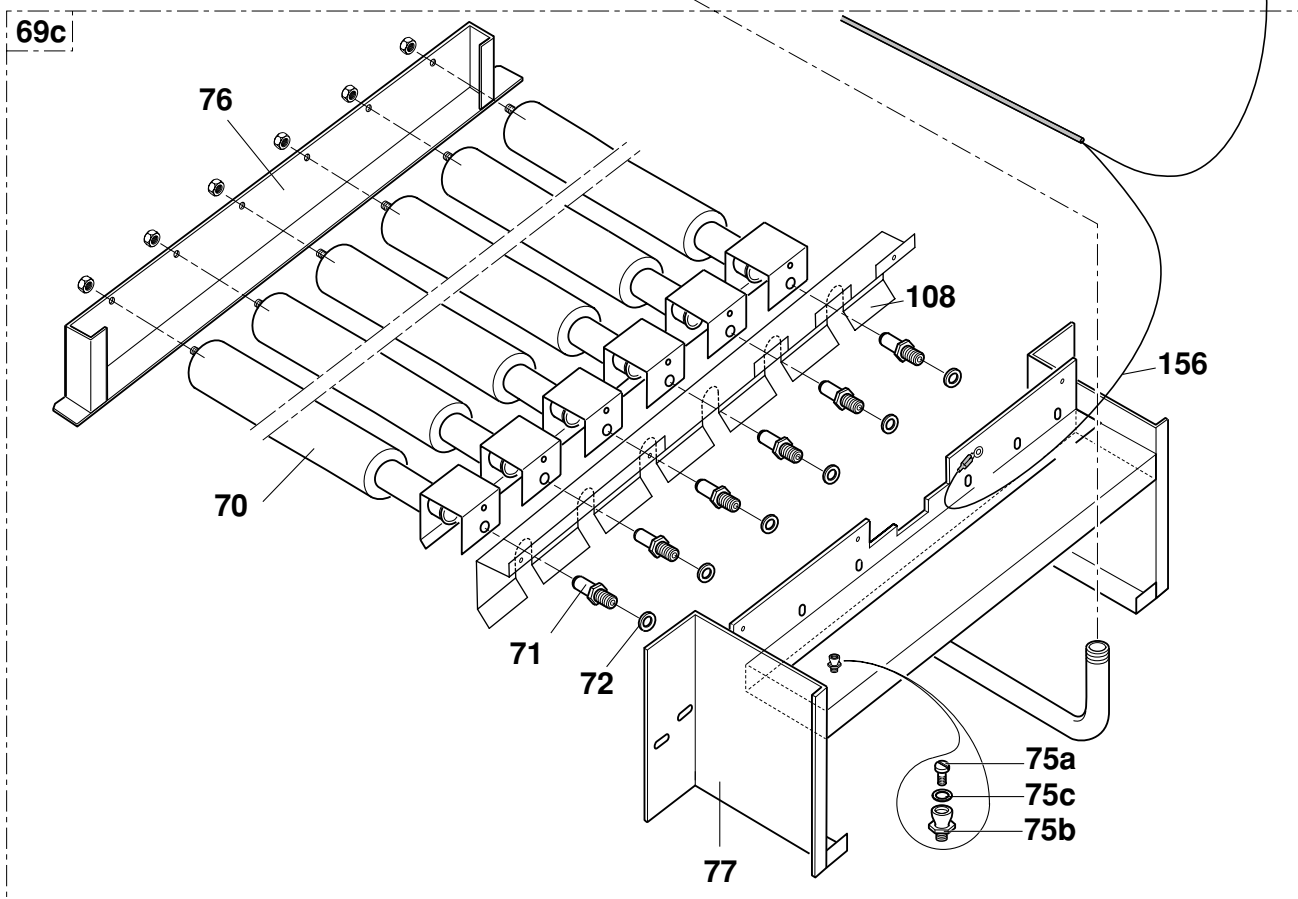
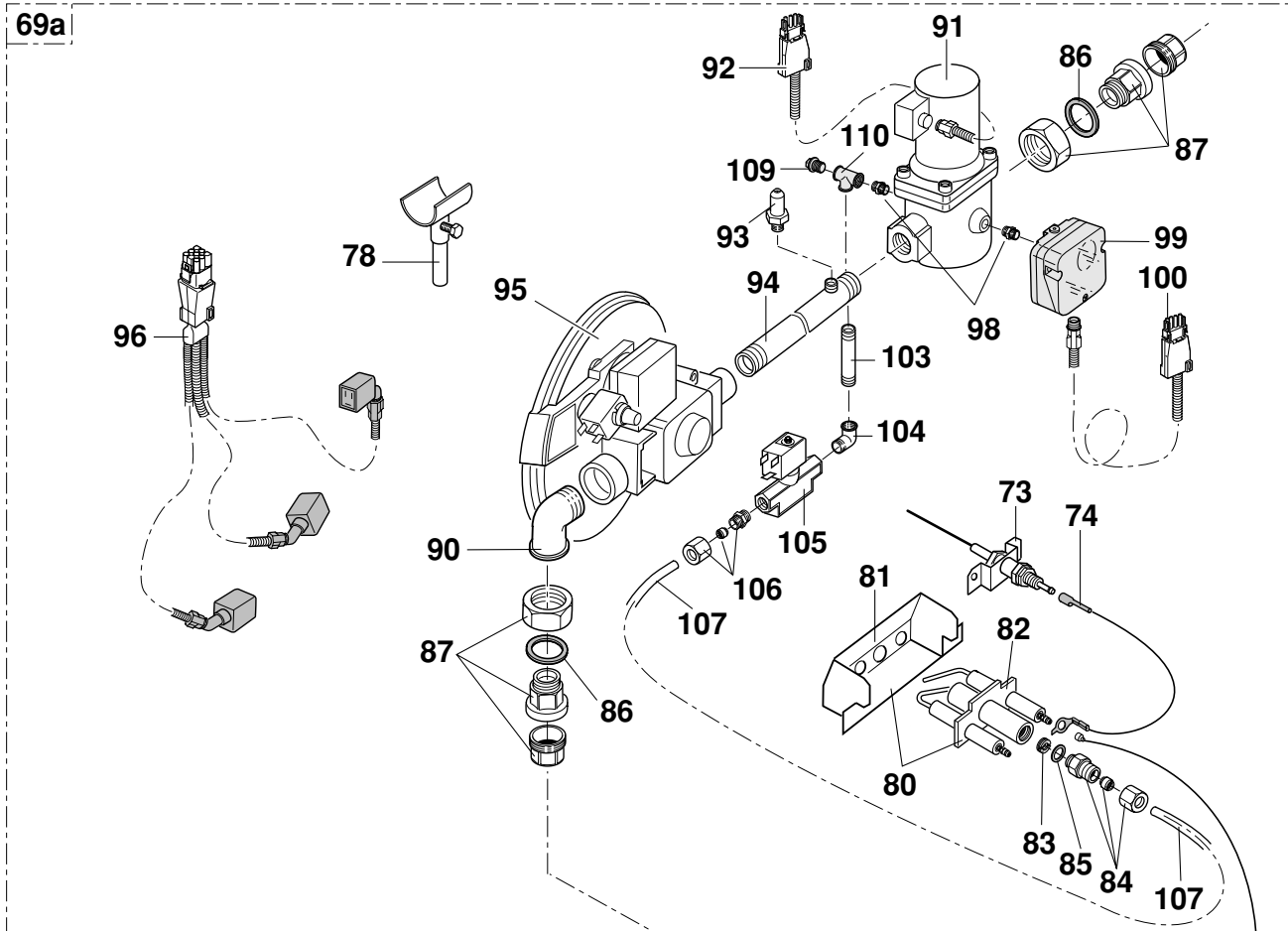

- Control panel

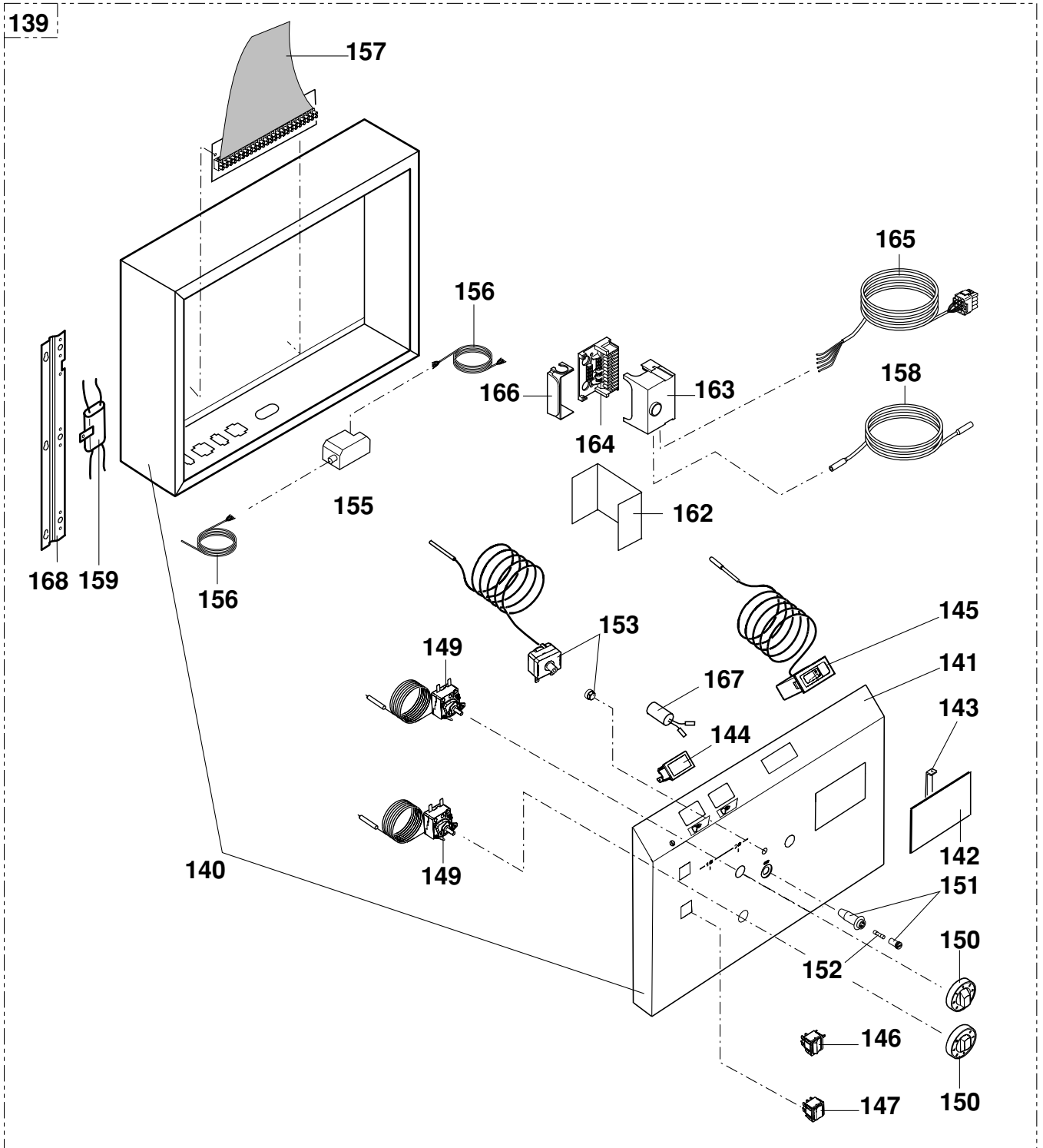

Ref.	Code no.	DESCRIPTION	Ref.	Code no.	DESCRIPTION
		Boiler body			
1	8345-7016	Complete left-hand side section	21	8345-7110	Assembled combustion chamber, AG 260
2	8345-7015	Complete right-hand side section	21	8345-7112	Assembled combustion chamber, AG 300
3	8345-0003	Intermediate section	21	8345-7114	Assembled combustion chamber, AG 340
4	8116-0571	Nipple	22	8345-1624	Complete combustion chamber plate, AG 140
5	8345-7020	Assembly rod, 10 dia., 670 long, for AG 140	22	8345-1625	Complete combustion chamber plate, AG 160
5	8345-7021	Assembly rod, 10 dia., 760 long, for AG 160	22	8345-1626	Complete combustion chamber plate, AG 180
5	8345-7022	Assembly rod, 10 dia., 870 long, for AG 180	22	8345-1627	Complete combustion chamber plate, AG 200
5	8345-7023	Assembly rod, 10 dia., 930 long, for AG 200	22	8345-1628	Complete combustion chamber plate, AG 220
5	8345-7024	Assembly rod, 10 dia., 1010 long, for AG 220	22	8345-1630	Complete combustion chamber plate, AG 260
5	8345-7025	Assembly rod, 10 dia., 1195 long, for AG 260	22	8345-1632	Complete combustion chamber plate, AG 300
5	8345-7026	Assembly rod, 10 dia., 1370 long, for AG 300	22	8345-1634	Complete combustion chamber plate, AG 340
5	8345-7027	Assembly rod, 10 dia., 1550 long, for AG 340	23	9425-0159	Combustion chamber side plate insulation
6	9758-1697	Painted plain flange	24	8425-0145	Combustion chamber rear plate insulation, 396 long (AG 220)
7	8345-0500	Painted tapped flange	24	9425-0147	Combustion chamber rear plate insulation, 570 long (AG 260)
8	9758-1123	Water flow connection piece, AG 140-180	24	9425-0148	Combustion chamber rear plate insulation, 658 long (AG 140)
8	9758-1124	Water flow connection piece, AG 200-340	24	9425-0149	Combustion chamber rear plate insulation, 746 long (AG 160 & 300)
9	9758-1126	Water return connection piece, AG 140-180	24	9425-0150	Combustion chamber rear plate insulation, 834 long (AG 180)
9	9758-1127	Water return connection piece, AG 200-220	24	9425-0151	Combustion chamber rear plate insulation, 922 long (AG 200 & 340)
9	9758-1128	Water return connection piece, AG 260-340	24	9425-0152	Special combustion chamber rear plate insulation, 616 long (AG 220 -340)
10	9758-1630	Flange gasket	25	9425-0180	Combustion chamber top plate insulation, 396 long
11	8345-7008	Lower casing support	25	9425-0182	Combustion chamber top plate insulation, 570 long
12	8345-0501	Positioning bracket	25	9425-0168	Combustion chamber top plate insulation, 658 long
13	9536-5611	1/2" pocket	25	9425-0169	Combustion chamber top plate insulation, 746 long
14	9536-5613	Contact spring for pocket	25	9425-0170	Combustion chamber top plate insulation, 834 long
15	9758-1286	Retaining spring for pocket	25	9425-0171	Combustion chamber top plate insulation, 922 long
16	9495-0110	1/2" plug	25	9425-0172	Special Combustion chamber top plate insulation, 616 long
16	9495-0140	3/4" plug	26	9425-0208	Combustion chamber bottom plate insulation, 238 long
17	9649-6100	Plastic button	26	9425-0209	Combustion chamber bottom plate insulation, 326 long
18	8345-8935	Complete underframe, AG 140	26	9425-0210	Combustion chamber bottom plate insulation, 414 long
18	8345-8936	Complete underframe, AG 160	26	9425-0211	Combustion chamber bottom plate insulation, 502 long
18	8345-8937	Complete underframe, AG 180	26	9425-0212	Combustion chamber bottom plate insulation, 590 long
18	8345-8938	Complete underframe, AG 200	26	9425-0213	Combustion chamber bottom plate insulation, 678 long
18	8345-8939	Complete underframe, AG 220	26	9425-0214	Combustion chamber bottom plate insulation, 766 long
18	8345-8941	Complete underframe, AG 260	26	9425-0215	Combustion chamber bottom plate insulation, 854 long
18	8345-8943	Complete underframe, AG 300	27	8345-8717	Complete tray, AG 140
18	8345-8945	Complete underframe, AG 340	27	8345-8718	Complete tray, AG 160
19	8800-8966	Metal filler box (1 kg)	27	8345-8719	Complete tray, AG 180
20	9425-0207	Cerablanket gasket	27	8345-8720	Complete tray, AG 200
21	8345-7104	Assembled combustion chamber, AG 140	27	8345-8721	Complete tray, AG 220
21	8345-7105	Assembled combustion chamber, AG 160	27	8345-8723	Complete tray, AG 260
21	8345-7106	Assembled combustion chamber, AG 180	27	8345-8725	Complete tray, AG 300
21	8345-7107	Assembled combustion chamber, AG 200	27	8345-8727	Complete tray, AG 340
21	8345-7108	Assembled combustion chamber, AG 220	28	9425-0275	Tray insulation, 436 wide, AG 180 & 260
			28	9425-0276	Tray indulation, 514 wide, AG 200

Ref.	Code no.	DESCRIPTION	Ref.	Code no.	DESCRIPTION
		Casing			
49	8350-8803	Specific parts for AG 140 casing	54	8350-8695	Complete top, AG 160
49	8350-8804	Specific parts for AG 160 casing	54	8350-8696	Complete top, AG 180
49	8350-8805	Specific parts for AG 180 casing	54	8350-8697	Complete top, AG 200
49	8350-8806	Specific parts for AG 200 casing	54	8350-8698	Complete top, AG 220
49	8350-8807	Specific parts for AG 220 casing	54	8350-8699	Complete top, AG 260
49	8350-8808	Specific parts for AG 260 casing	54	8350-8800	Complete top, AG 300
49	8350-8809	Specific parts for AG 300 casing	54	8350-8801	Complete top, AG 340
49	8350-8810	Specific parts for AG 340 casing	55	8345-8814	Complete right-hand side front panel, AG 140-180
49	8345-8894	Common parts for AG 140-180 casing	55	8345-8815	Complete right-hand side front panel, AG 200-340
49	8345-8895	Common parts for AG 200-340 casing	56	8345-8818	Complete right-hand side rear panel, AG 140-180
50	8340-1507	Complete front casing support, AG 140	56	8345-8819	Complete right-hand side rear panel, AG 200-340
50	8340-1508	Complete front casing support, AG 160	57	8345-8816	Complete left-hand side front panel, AG 140-180
50	8340-1509	Complete front casing support, AG 180	57	8345-8817	Complete left-hand side front panel, AG 200-340
50	8340-1510	Complete front casing support, AG 200	58	8345-8820	Complete left-hand side rear panel, AG 140-180
50	8340-1511	Complete front casing support, AG 220	58	8345-8821	Complete left-hand side rear panel, AG 200-340
50	8340-1513	Complete front casing support, AG 260	59	8345-7011	Rear upper panel, AG 140-180
50	8340-1515	Complete front casing support, AG 300	59	8345-7012	Rear upper panel, AG 200-340
50	8340-1517	Complete front casing support, AG 340	60	8345-0618	Complete rear lower panel, AG 140
51	8345-8825	Lower front panel, AG 140	60	8345-0619	Complete rear lower panel, AG 160
51	8345-8826	Lower front panel, AG 160	60	8345-0620	Complete rear lower panel, AG 180
51	8345-8827	Lower front panel, AG 180	60	8345-0621	Complete rear lower panel, AG 200
51	8345-8828	Lower front panel, AG 200	60	8345-0622	Complete rear lower panel, AG 220
51	8345-8829	Lower front panel, AG 220	60	8345-0624	Complete rear lower panel, AG 260
51	8345-8831	Lower front panel, AG 260	60	8345-0626	Complete rear lower panel, AG 300
51	8345-8833	Lower front panel, AG 300	60	8345-0628	Complete rear lower panel, AG 340
51	8345-8835	Lower front panel, AG 340	61	8345-0557	Cover
52	8350-8678	Intermediate front panel, AG 140	61a	8345-0558	Water outlet cover
52	8350-8679	Intermediate front panel, AG 160	62	8340-8800	Wiring duct
52	8350-8680	Intermediate front panel, AG 180	63	8345-0700	Cable support
52	8350-8681	Intermediate front panel, AG 200	64	8340-8047	Panel insulation support
52	8350-8682	Intermediate front panel, AG 220	65	8340-4036	Control panel insulation
52	8350-8683	Intermediate front panel, AG 260	66	9649-6161	Rivet stud
52	8350-8684	Intermediate front panel, AG 300	67a	9531-5801	Gland
52	8350-8685	Intermediate front panel, AG 340	67b	9531-5406	Lock nut
53	8350-8686	Upper front panel, AG 140	68	8345-7057	Bag of screws for casing
53	8350-8687	Upper front panel, AG 160	68a	9486-1632	Logo HOVAL
53	8350-8688	Upper front panel, AG 180	68b	9486-1633	Logo AtmoGas
53	8350-8689	Upper front panel, AG 200			
53	8350-8690	Upper front panel, AG 220			
53	8350-8691	Upper front panel, AG 260			
53	8350-8692	Upper front panel, AG 300			
53	8350-8693	Upper front panel, AG 340			
54	8350-8694	Complete top, AG 140			

Ref.	Code no.	DESCRIPTION	Ref.	Code no.	DESCRIPTION
		Gas line			
69a	8350-8528	HONEYWELL gas line (AG 140-180)	86	9501-3066	Flat seal, 62 x 46 x 2 (AG 200-220)
69a	8350-8529	HONEYWELL gas line (AG 200-220)	86	9501-3067	Flat seal, 78 x 60 x 2 (AG 260-340)
69a	8350-8530	HONEYWELL gas line (AG 260-340)	87	9495-8180	Connecting sleeve no. 331, 1" (AG 140-180)
69c	8350-8626	Complete FURIGAS burner drawer, AG 140	87	9495-8250	Connecting sleeve no. 331, 1 1/2" (AG 200-220)
69c	8350-8627	Complete FURIGAS burner drawer, AG 160	87	9495-8293	Connecting sleeve no. 331, 2" (AG 260-340)
69c	8350-8628	Complete FURIGAS burner drawer, AG 180	90	9492-0297	Male-female bend, 1"
69c	8350-8629	Complete FURIGAS burner drawer, AG 200	90	9492-0395	Male-female bend, 1 1/2"
69c	8350-8630	Complete FURIGAS burner drawer, AG 220	90	9492-0444	Male-female bend, 2"
69c	8350-8631	Complete FURIGAS burner drawer, AG 260	91	9536-1650	Safety valve, HO VE4025A1004 (AG 140-180)
69c	8350-8632	Complete FURIGAS burner drawer, AG 300	91	9536-1651	Safety valve, HO VE4025A1003 (AG 200-220)
69c	8350-8633	Complete FURIGAS burner drawer, AG 340	91	9536-1652	Safety valve, HO VE4025A1002 (AG 260-340)
70	9758-0106	60 dia. FURIGAS burner	92	8350-4909	Bundle for safety valve
71	9758-0800	3.9 dia. H gas injection nozzle	93	9536-0220	Pressure tap
72	9501-9165	Aluminium seal for nozzle, 12.2 dia. x 20 x 1.5	94	9758-1131	Gas inlet tube, 1"
73	8345-7007	Complete ionising sensor	94	9758-1132	Gas inlet tube, 1 1/2"
74	8345-4916	Ionising sensor to pilot flame connection circuit	94	9758-1133	Gas inlet tube, 2"
75a	9755-7175	Pressure screw	95	8345-7231	Valve, 1", HO V4085 P2014 (AG 140-180)
75b	9774-9335	Pressure tap	95	8345-7232	Valve, 1" 1/2 HO V4085 P2022 (AG 200-220)
75c	9501-9145	Aluminium seal, 6.2 dia. x 10 x 1.5	95	8345-7233	Valve, 2" HO V4085 P2006 (AG 260-340)
76	8345-0537	Rear burner support, AG 140	96	8350-4905	Gas line bundle, 20 mbar
76	8345-0538	Rear burner support, AG 160	98	9494-6035	Double nipple, no. 280 1/4"
76	8345-0539	Rear burner support, AG 180	99	9758-0612	Gas pressure sensitive switch, 1/4"
76	8345-0540	Rear burner support, AG 200	100	8350-4910	Bundle for gas pressure sensitive switch, 20 mbar
76	8345-0541	Rear burner support, AG 220	103	9150-8010	Connecting tube, 1/4"
76	8345-0543	Rear burner support, AG 260	104	9492-0103	Bend no. 92, 1/4"
76	8345-0545	Rear burner support, AG 300	105	9536-1538	Gas ignition valve, 1/4"
76	8345-0547	Rear burner support, AG 340	106	9496-0052	Male union, 1/4" - D.6
77	9758-1108	Assembled supply rail, AG 140	107	9754-9438	Pilot flame gas supply tube - 20 mbar
77	9758-1109	Assembled supply rail, AG 160	108	8350-8012	Combustion chamber plate, AG 140
77	9758-1110	Assembled supply rail, AG 180	108	8350-8013	Combustion chamber plate, AG 160
77	9758-1111	Assembled supply rail, AG 200	108	8350-8014	Combustion chamber plate, AG 180
77	9758-1112	Assembled supply rail, AG 220	108	8350-8015	Combustion chamber plate, AG 200
77	9758-1114	Assembled supply rail, AG 260	108	8350-8016	Combustion chamber plate, AG 220
77	9758-1116	Assembled supply rail, AG 300	108	8350-8018	Combustion chamber plate, AG 260
77	9758-1118	Assembled supply rail, AG 340	108	8350-8020	Combustion chamber plate, AG 300
78	8345-8960	Complete gas rail support assembly	108	8350-8022	Combustion chamber plate, AG 340
80	8345-8995	Assembled ignition burner (with support)	109	9495-0050	Plug, 1/4"
81	8340-8014	Pilot flame support	110	9492-6030	Tee, 1/4"
82	8345-4702	Ignition burner			
83	9758-0402	Pilot flame injection nozzle, 0.75 mm			
84	9496-0050	Cylindrical male gas pipe union			
85	9501-1732	Copper seal, 10.2 x 12.5 x 1			
86	9501-3064	Flat seal, 44 x 32 x 2 (AG 140-180)			

Hoval

Conservation of Energy
Protection of the Environment

HOVAL Limited, Northgate, Newark, Notts NG24 1JN

Tel : 01636 672711 Fax : 01636 673532

Assembly Atmogas 140-340





Tools required :

- 8 spanner
- 10 spanner
- 13 spanner
- Philipps head screwdriver
- Simplified JD assembly tool (8-14 sections) or JD-TE assembly tool

Packaging :

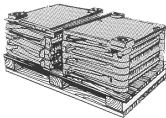
The tables below provide the number of packages which make up the boiler. The packages are listed in the order in which they are opened during assembly.

● Boiler with unassembled body

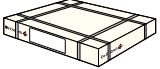
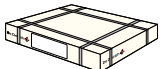
Type of boiler	AG 140	AG 160	AG 180	AG 200	AG 220	AG 260	AG 300	AG 340
 - Gas line package, 20/25 mbar with underframe	DP169	DP170	DP171	DP172	DP173	DP174	DP175	DP176
 - Boiler body : Left-hand side section 8345-0001	1	1	1	1	1	1	1	1
Intermediate section 8345-0003	6	7	8	9	10	12	14	16
Right-hand side section 8345-0002	1	1	1	1	1	1	1	1
 - Set of two assembly rods	8350-7121	8350-7122	8350-7123	8350-7124	8350-7125	8350-7126	8350-7127	8350-7128
 - Package of unassembled body accessories	DP196	DP197	DP198	DP199	DP200	DP201	DP202	DP203
 - Flue draught diverter package + boiler body insulating material	AV18	AV19	AV20	AV21	AV22	AV24	AV26	AV28
 - Casing package. Specific parts	DP185	DP186	DP187	DP188	DP189	DP190	DP191	DP192
 - Casing package. Common parts	DP193	DP193	DP193	DP194	DP194	DP194	DP194	DP194
- Control panel	DP195	DP195	DP195	DP195	DP195	DP195	DP195	DP195

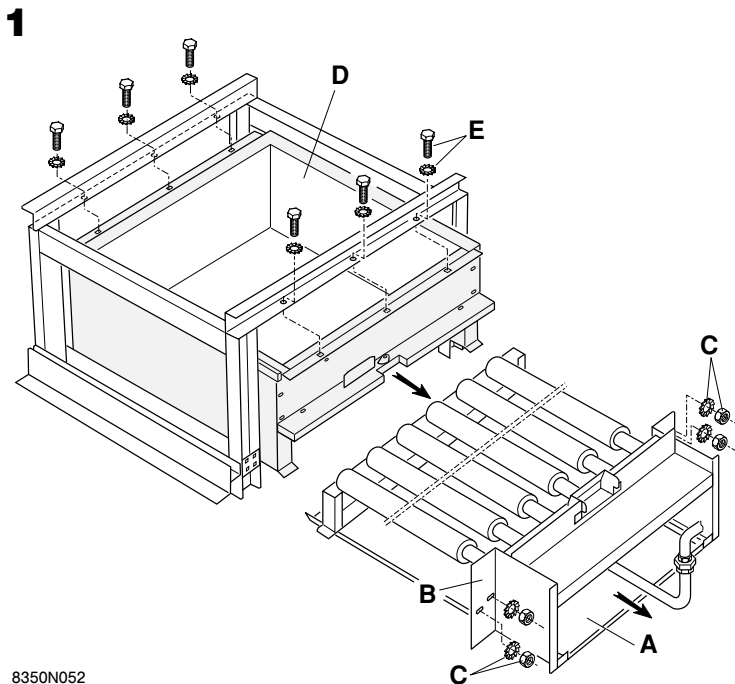

Proceed as follows before mounting the sections on the underframe :

- remove tray **A** located under the burner drawer.
- unscrew the four **C** nuts and serrated washers located on either side of burner drawer **B** (with a 10 spanner) and remove the drawer.
- remove combustion chamber **D**, fastened with the six H8x30 screws **E** and serrated washers located at the front and rear of the combustion chamber (use a 13 spanner).

In this way, the sections can be assembled without damaging the tightness of the upper part of the combustion chamber.

2 Assembling the heating sections

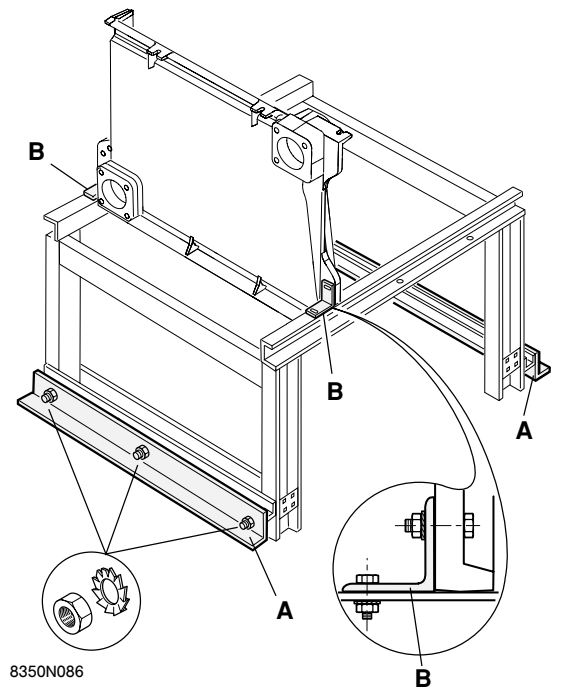

- Fix the two lower casing brackets **A**, using three H5 nuts + DE5 washers.
- Fix the two positioning angles **B** onto the underframe (on the right or left-hand side) using two H 6x25 screws and two DE 6 serrated washers two H6 nuts (10 spanner).
- Put the side section in place and fasten it to angles **B** with two H 8x30 screws, H8 nuts and M8N washers.

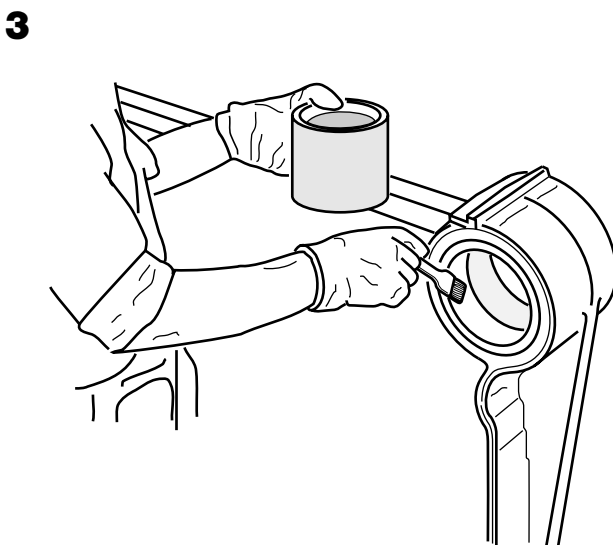

Clean the bores with thinner and coat them with the lubricant supplied with the sections.

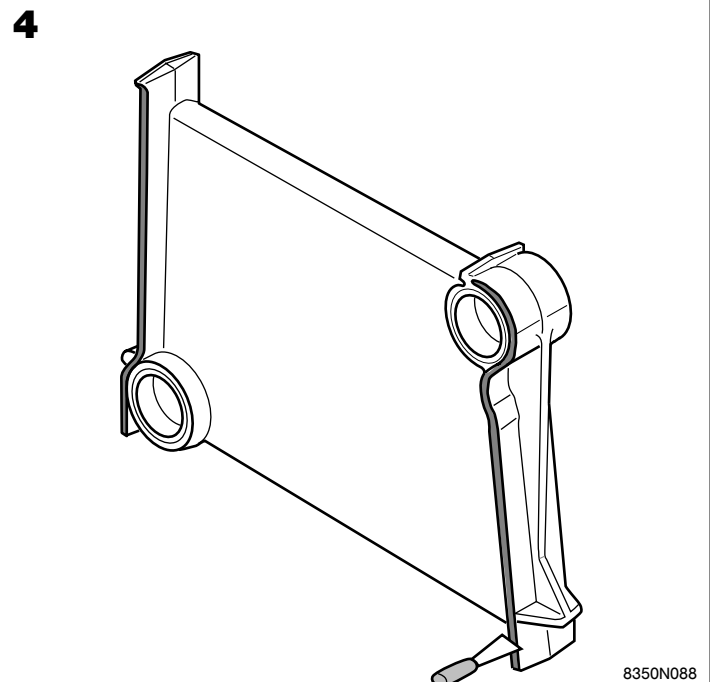

Carefully apply filler on the sealing grooves with a spatula, so as to ensure correct tightness.

5

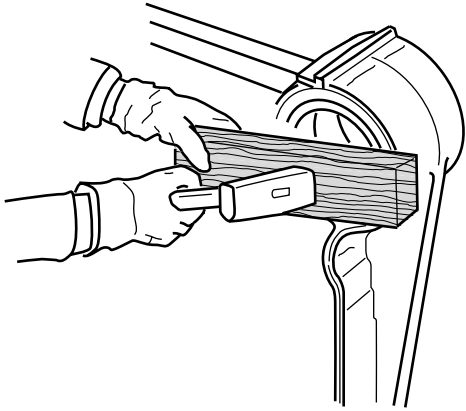

8350N089

Clean the fittings with thinner. Coat them with the lubricant supplied with the sections.
Press in the two nipples moderately, using a piece of wood.

6

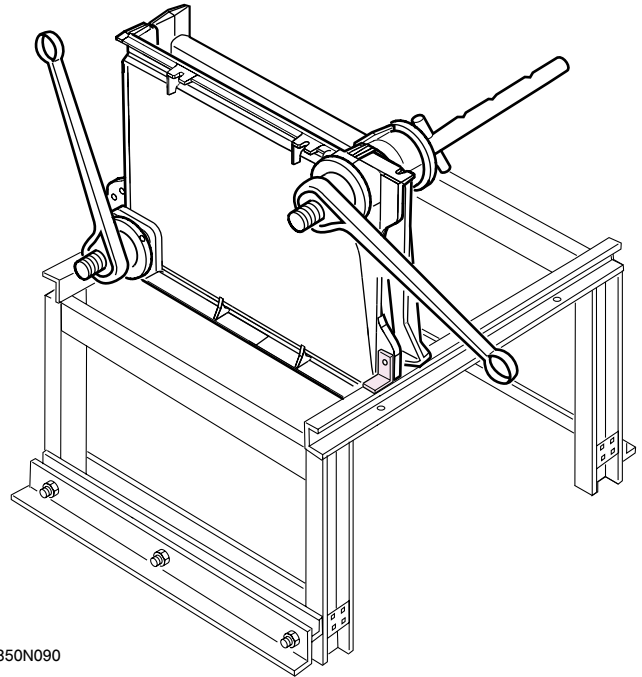

8350N090

Fit the first intermediate element.
Put the assembly tool in place.
Tighten gradually so as to bring about simultaneous and identical closing of both upper and lower connections.

7

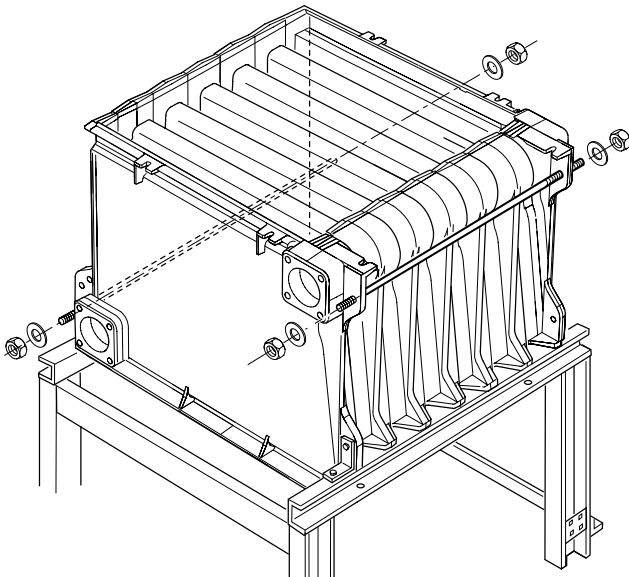

8350N091

Assemble the remaining intermediate sections, as per the instructions under figures 3, 4, 5 and 6.
Place the second side section and fasten.
Leave the assembly tool on the assembly.
Fix the assembly rods (with M10N washers and H10 nuts).
Remove the assembly tool.

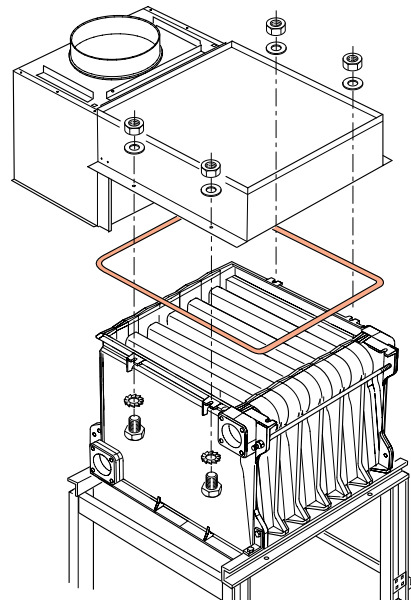
8 **Assembling the draught diverter**

8350N092

Fix the 7 diameter seal onto the top of the body with filler.
Start at the rear.
Install the draught diverter and fasten it to the body with four H8x30 screws, four DE8 serrated washers, four nuts and four M8N washers (13 spanner).

9

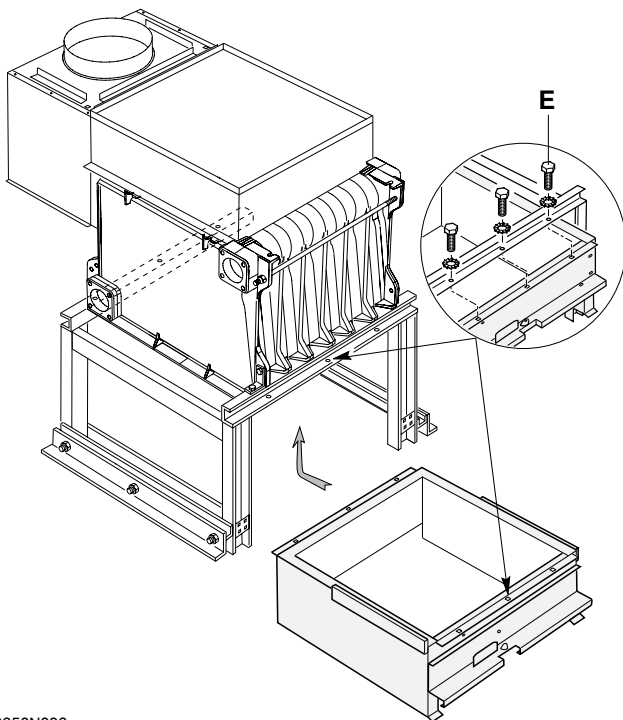

8350N093

- Put the combustion chamber in as shown above and fasten it to the underframe at the front and rear with the six H 8x30 screws **E** and six DE8 serrated washers (with a 13 spanner) which were removed in step 1.

10

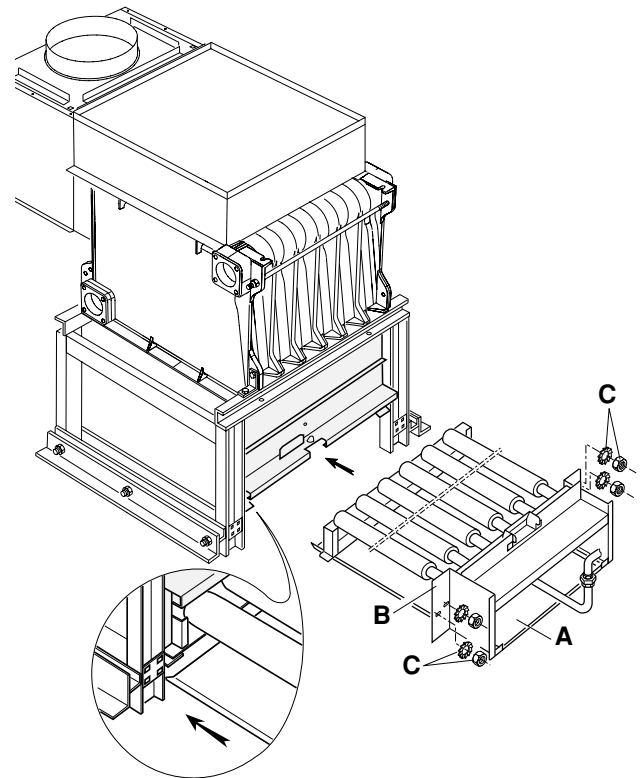

8350N094

Fit the burner drawer into the grooves designed for this purpose on the combustion chamber, and fasten it with H6 nuts and DD 6 serrated washers. Slide the tray into place under the burner drawer and push it home.

11

- Fix water flow flange **A**, return flange **B**, tapped flange **C** and plain flange **D** : Four M 12 bolts four H12 nuts (19 spanner) and one seal are required for each flange.

- **The pocket opening must in all cases be placed on the left-hand side of the boiler, that is :**

- If the **flow** and **return** are located on the **left-hand side**, follow the illustration : pocket opening turned towards the front.
- If the **flow** and **return** are located on the **right-hand side**, fit tapped flange **C** on the left-hand side at the top, flange **D** on the left-hand side and 1/2" plug **E** on the right-hand side, in the pocket opening of flow flange **A**.

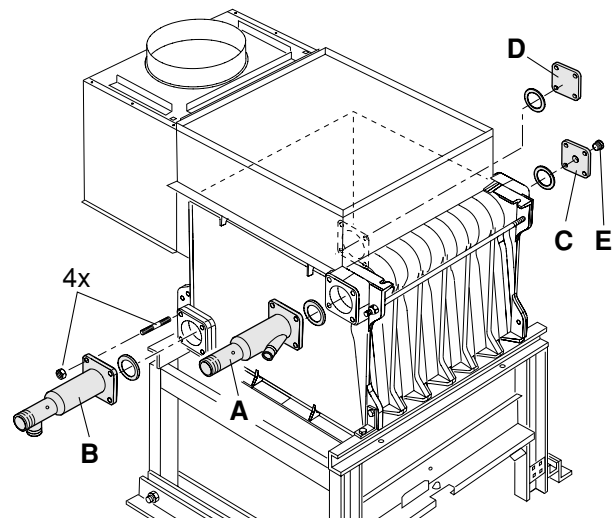

8350N095

12 Assembling the insulation

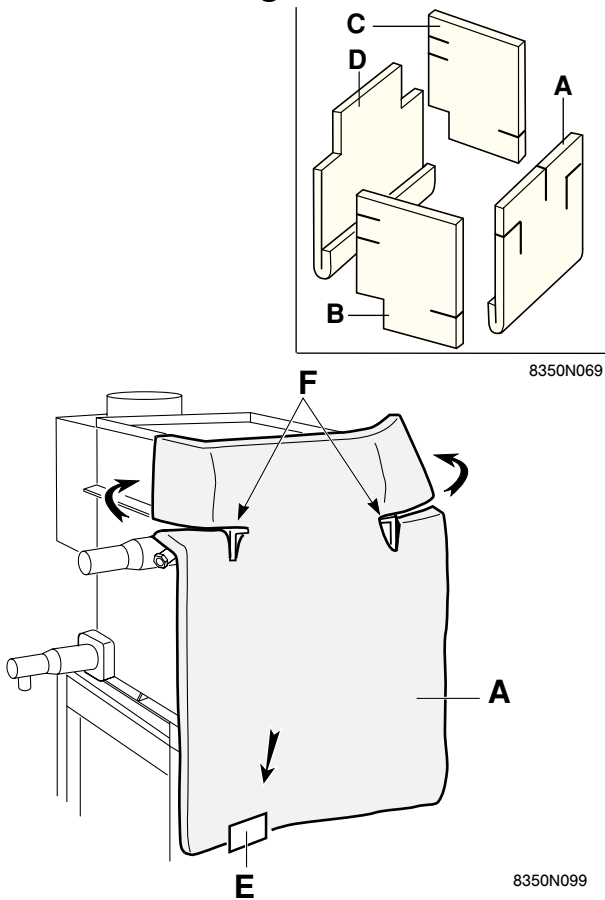

- Place front insulation panel **A**. Insert it into metal retaining bracket **E** located at the bottom of the combustion chamber
- Bring fastening points **F** out through the cut-outs in the insulation panel.

13

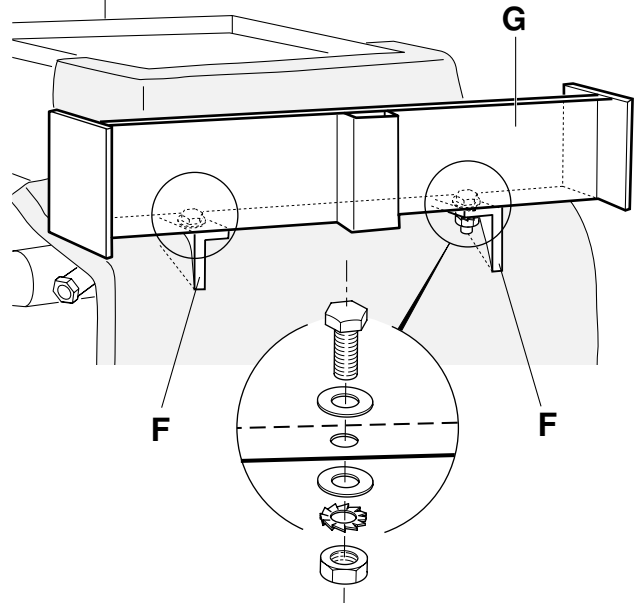

8350N100

- Fix panel-support cross-piece **G** onto fastening points **F** with two H 8x30 screws, two H8 nuts, two DE8 serrated washers (13 spanner) and four flat washers.

14

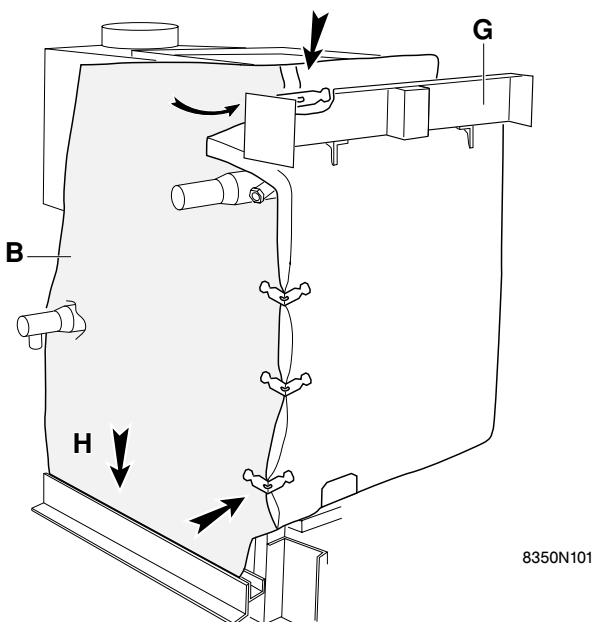

- Fit left-hand insulating panel **B**, and insert the bottom of the panel into retaining slot **H**.
- Insert the flap under cross-piece **G** and fasten with clamps.

15

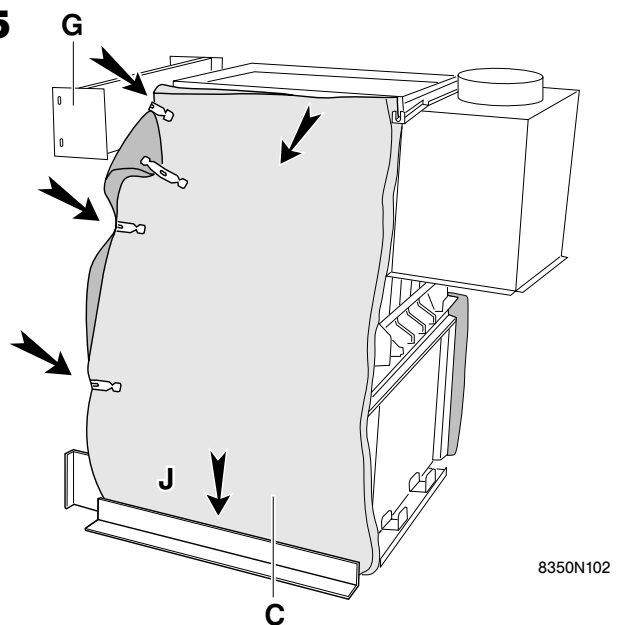

- Fit second side panel **C**. Slide the bottom of the panel into retaining slot **J**.
- Insert the flap under front cross-piece **G** and fasten with clamps.

16

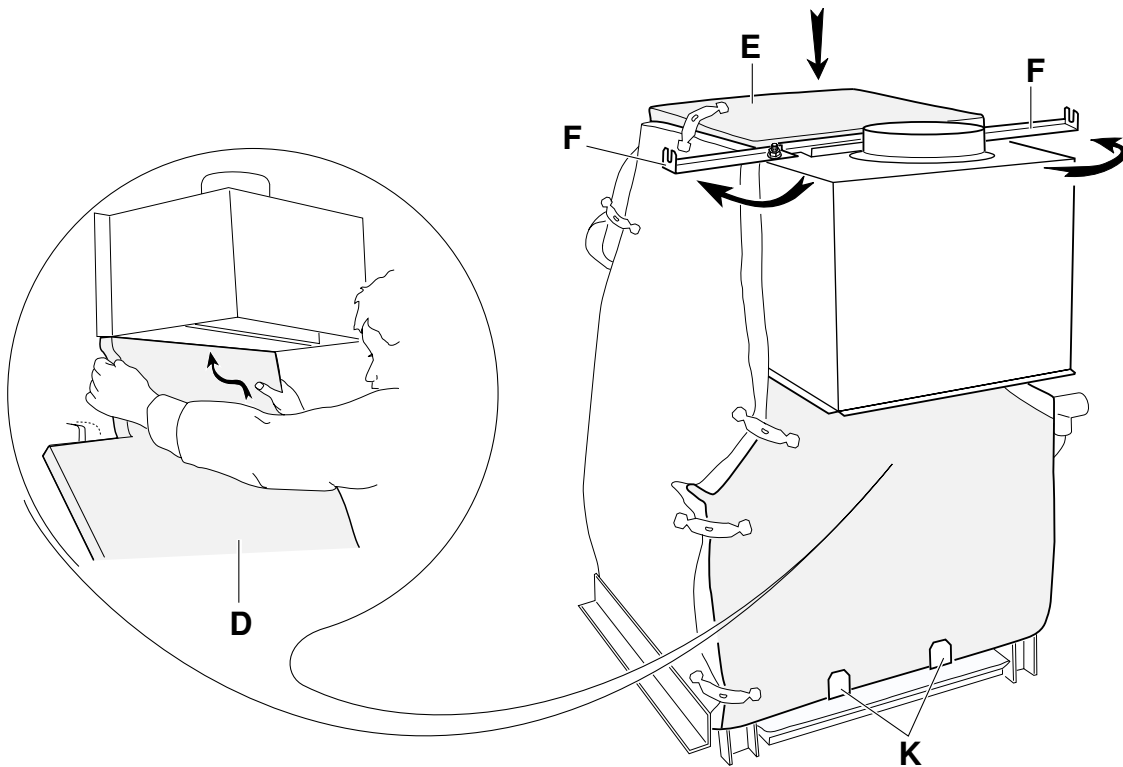

8350N104

- Insert rear insulation panel **D** between the body of the boiler and the draught diverter (see detailed drawing). Insert the bottom of the panel into the two retaining brackets **K** designed for this purpose.
- Insert the sides of the insulation under the side insulation panel and fasten with clamps.
- Place upper insulation panel **E** on the draught diverter
- Turn the two casing fastening brackets **F** outwards, perpendicular to the sides of the boiler and fasten with clamps.

17 Assembling the casing

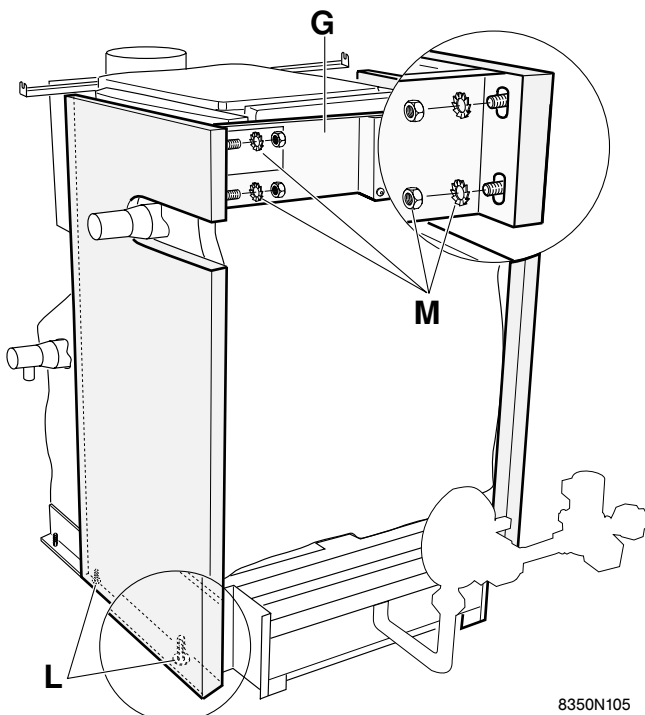

8350N105

- Assemble the left and right-hand front panels : clip them into rivet studs **L** located on the lower brackets.
- Fasten each panel with two H6 nuts and 2 serrated washers to panel-support cross piece **G** (10 spanner).

18

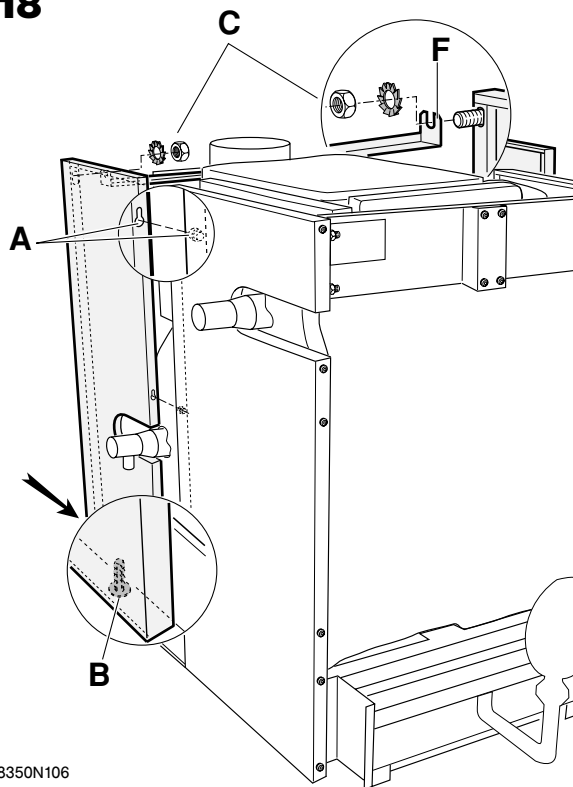

8350N106

- Fix the left and right-hand rear panels onto sockets **A** on the front side panels, clip them into rivet studs **B** located on the lower bracket.
- Fasten each panel with one H6 nut and one serrated washer **C** (10 spanner) onto casing fastening brackets **F**.

19

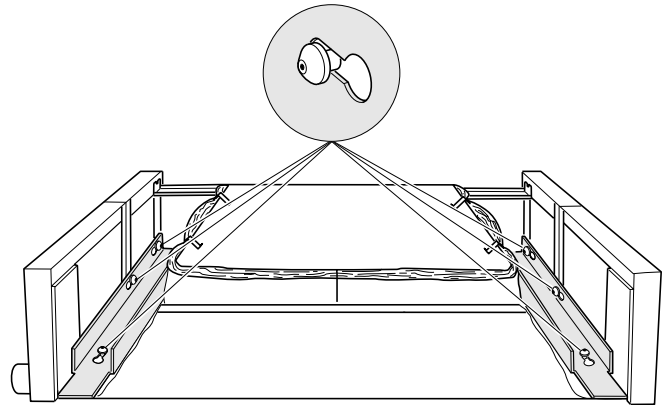

8350N071

- Fit the two horizontal wiring ducts along the left and right-hand side panels.

20

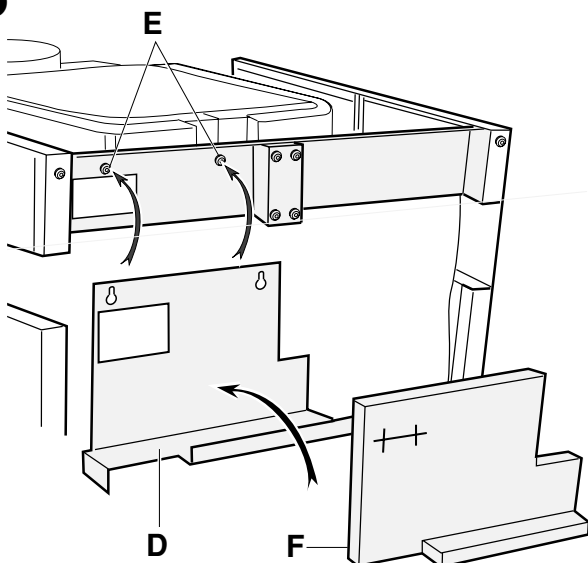

8350N118

- Fit insulation material support **D** onto sockets **E** of the panel support cross piece and put insulation **F** in place, on support **D**.

21

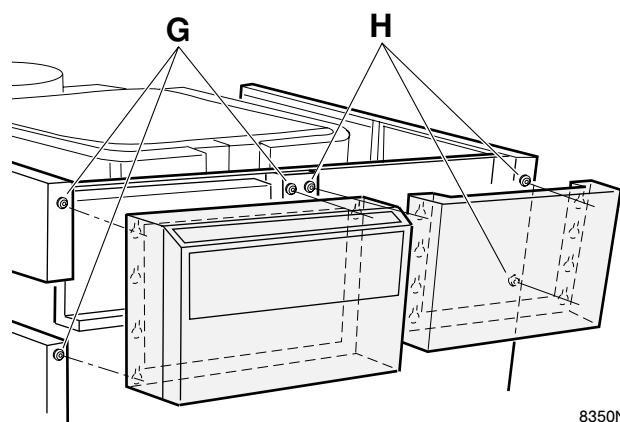

8350N127

- Fasten the control panel onto sockets **G**.
- Fasten the top front panel onto sockets **H**.

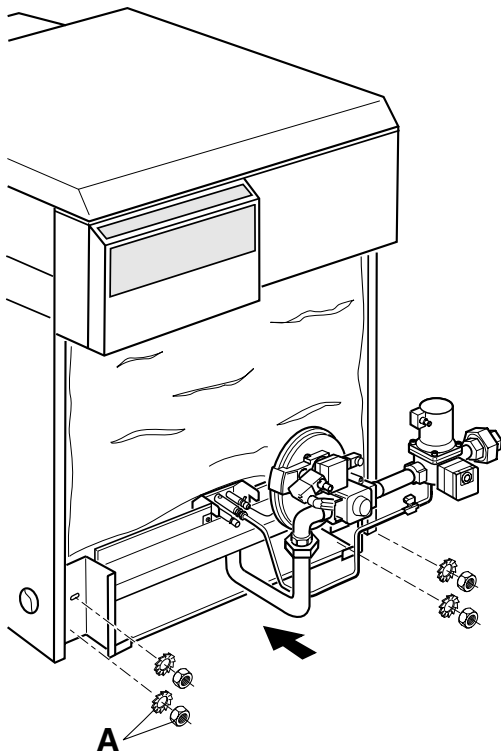
22 Gas line assembly

8350N070 A

Fix the assembled gas line with four nuts and serrated washers **A** (10 spanner).

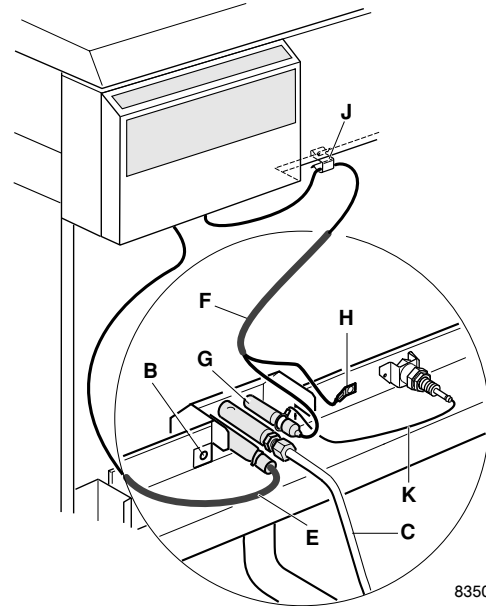
23

8350N074 A

- If necessary, loosen the two pilot flame fastening screws **B** slightly, and position the pilot flame behind the cut-out of the combustion chamber plate and fasten the screws.
- Connect the gas supply line to pilot flame **C**.
- Connect earthing wire **D** to connector **H** located on the right-hand side of the pilot flame.
- Connect ignition cable **E**.
- Connect the two-wire cable **F** (one of the wires is connected to ionising sensor **G**, the other to earthing terminal **H**) and fasten it with clip **J**.
- Put the connecting cable **K** between the ionising sensor and the pilot flame in place.

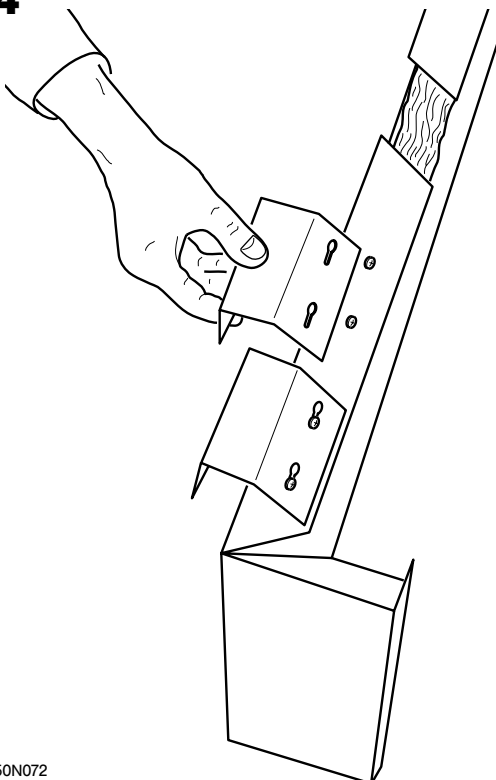
24

8350N072

Assemble the cable supports onto the lower front panel using SIM EC CB 3.94 x 12.7 screws and fasten the panel.

25

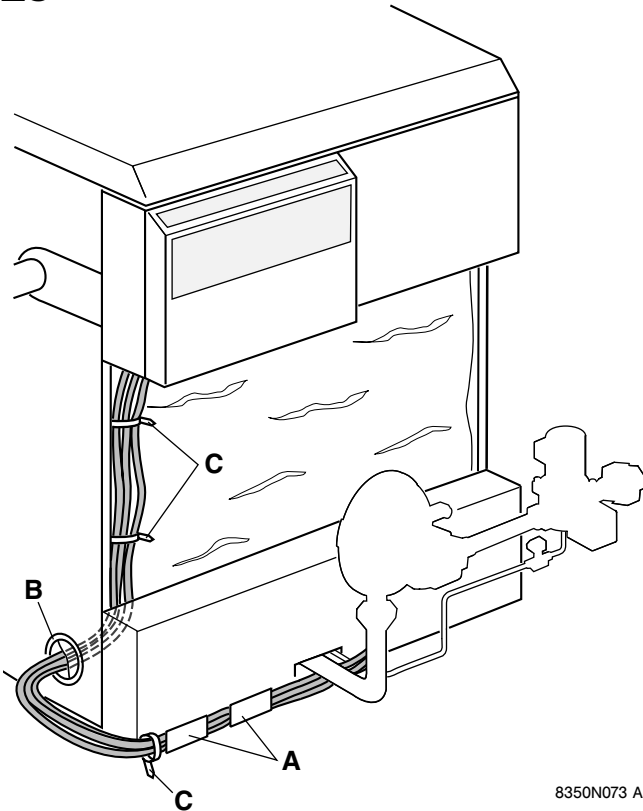

8350N073 A

Fit the cable form into brackets **A**, thread them through aperture **B**, up to the panel. Fix the cable form with cable clamps **C**.

26

Inserting the cables into the left-hand flange with pocket

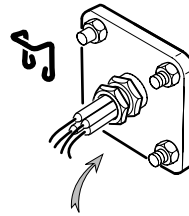

8350N096

or Inserting the cables into the left-hand flow flange

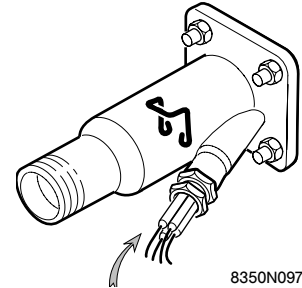

8350N097

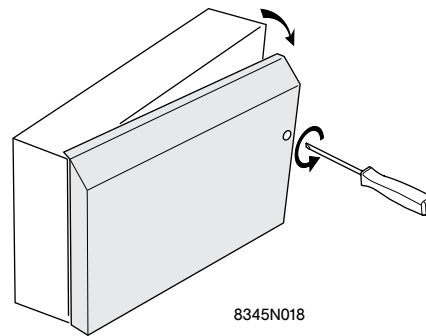

8345N018

- The cables must necessarily be placed in the pocket located on the **left-hand side** of the boiler. Push them through the pocket opening.
- To open the panel, unscrew the screw located on the right of the panel. Pull to open.

27

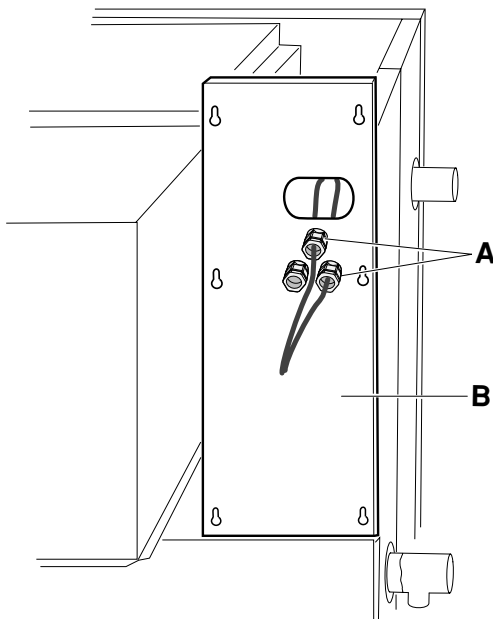

8350N119

Bring the supply and heating pump cables up to the panel and fix them in the wiring ducts with cable clamps. The cables are positioned and held in place via a cable gland located on the rear plate which is not fixed.

28

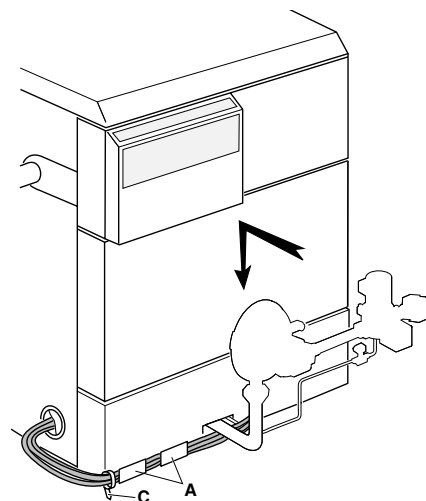

8350N075 B

- Make the electrical connections as directed in the chapter 8.
- Fit the intermediate front panel.



Warning : The cables must not slip beneath the boiler, as they could get damaged. Fix them carefully with cable clamps **C** and put them into cable brackets **D** on the lower panel, as shown in fig. 25.

29

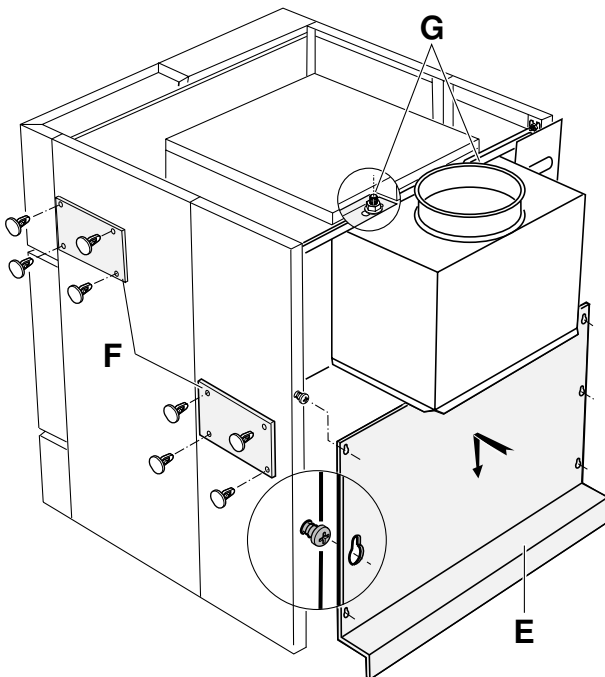

8350N120

- Fix lower rear panel **E** with SIM screws and fasten the screws.
- Clip on covers **F** with the rivet studs.
- Adjust the position of the casing by tightening or loosening the two fastening nuts on casing brackets **G**.

30

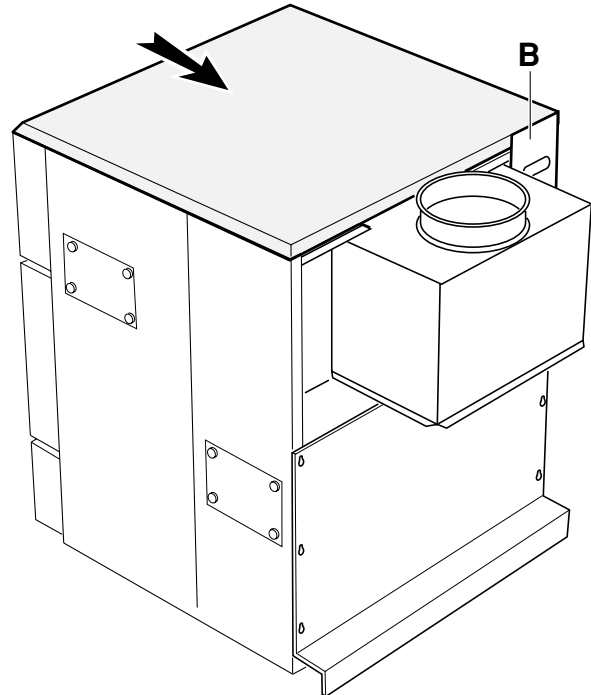

8350N121

- Clear right-hand rear plate **B** (not fixed) and put the top in place.

31

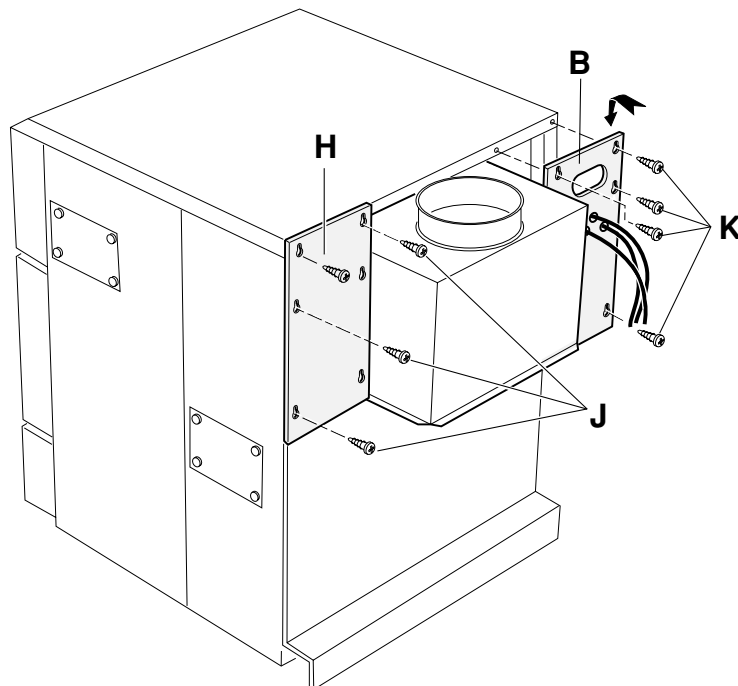

8350N122

- Fit left-hand rear plate **H** and fasten with the four self tapping screws **J**.
- Fit right-hand rear plate **B** on the cable side, and fasten self tapping screws **K**. These two panels must be fastened in such a way that they can only be removed with a tool.

Hoval

Conservation of Energy
Protection of the Environment

HOVAL Limited, Northgate, Newark, Notts NG24 1JN

Tel : 01636 672711 Fax : 01636 673532