

installation and servicing

icos system

Your Ideal installation and servicing guide

HE24

For users guide see reverse of book

When replacing any part on this appliance, use only spare parts that you can be assured conform to the safety and performance specification that we require. Do not use reconditioned or copy parts that have not been clearly authorised by Ideal Boilers.

February 2004 UIN 200 214 A02

i **Ideal** BOILERS
ENGINEERED FOR PEACE OF MIND

GENERAL

Table 1 - General Data

Gas supply	2H-G20-20mbar	
Gas Supply Connection	Rc1/2 (1/2" BSP Female)	
Injector size	Stereomatic 5.6mm dia.	
Flow Connection	Central Heating	22mm copper compression
Return Connection	Central Heating	22mm copper compression
Flue Terminal Diameter	mm (in)	100 (4)
Maximum Working Pressure (Sealed Systems)	bar (lb/in ²)	2.65 (38.5)
Electrical Supply / Power consumption	230 V ~ 50 Hz. / 148 W	
Fuse Rating	External : 3A Internal : T3.15A L 250V	
Water content	Central Heating	litre (gal)
		2.0 (0.44)
Packaged Weight	kg (lb)	47 (103)
Maximum Installation Weight	kg (lb)	40 (88)
Boiler Casing Size	Height	mm (in)
		687 (27)
	Width	mm (in)
		390 (15 3/8)
	Depth	mm (in)
		278 (11)

Table 2 - Performance Data

Boiler Size		Max	Min
Boiler input 'Q' =	Nett CV	kW	24.4
		Btu/h	83 300
Gross CV	kW	27.1	10.1
	Btu/h	92 500	34 400
Boiler output 'P' =	Gas consumption	l/s (cu.ft/h)	0.70 (89.0)
	70 °C Mean water	kW	23.4
	temperature	Btu/h	80,000
	40 °C Mean water	kW	25.1
temperature	Btu/h	85 700	32 800
Seasonal efficiency (SEDBUK) *	Band A	[90.2]%	
NOx classification	Class 5		

* The value is used in the UK Government's Standard Assessment Procedure (SAP) for energy rating of dwellings. The test data from which it has been calculated have been certified by a notified body.

Note. Gas consumption is calculated using a calorific value of 38.7 MJ/m³ (1038 Btu/ft³) gross or 34.9 MJ/m³ (935 Btu/ft³) nett

To obtain the gas consumption at a different calorific value:

a. For l/s - divide the gross heat input (kW) by the gross C.V. of the gas (MJ/m³)

b. For ft³/h - divide the gross heat input (Btu/h) by the gross C.V. of the gas (Btu/ft³)

Key to symbols

GB = United Kingdom IE = Ireland (Countries of destination)

PMS = Maximum operating pressure of water

C₁₃ C₃₃ C₆₃ = A room sealed appliance designed for connection via ducts to a horizontal or vertical terminal, which admits fresh air to the burner and discharges the products of combustion to the outside through orifices which, in this case, are concentric. The fan is up stream of the combustion chamber.

I_{2H} = An appliance designed for use on 2nd Family gas, Group H only.

CAUTION. To avoid the possibility of injury during the installation, servicing or cleaning of this appliance care should be taken when handling edges of sheet steel components.

GENERAL

icos system HE24

Natural Gas only

G.C. Appliance No. 41 397 82

PI No. 0063 BO 93316

Destination Country: GB, IE

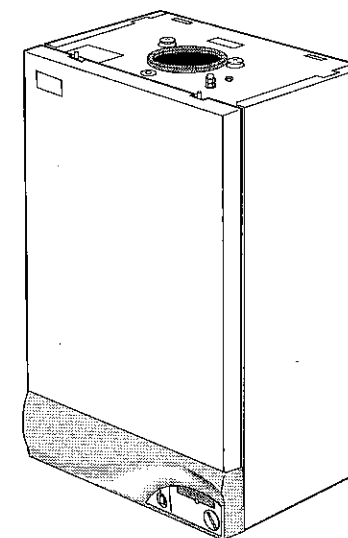

CONTENTS

Air Supply	7
Boiler Clearances	6
Boiler Interlocks	8
Boiler Exploded Diagram	10 & 11
Condensate Drain	8 & 21
Electrical Connections	23
Electrical Supply	8
Extension Ducts - Fitting	17
Fault Finding	45-48
Flow Wiring Diagram	26
Flue Fitting	15
Flue Installation	7
Gas Safety Regulations	5
Gas Supply	7
Installation	11-29
Mandatory Requirements	5-10
Pump	42
Servicing	30-44
Short List of Parts	49
Thermostatic Radiator valves	8
Water and Systems	7-10
Water Connections	20
Water Treatment	10
Wiring Diagrams	23-26

For GB, to comply with Building Regulations Part L1 (Part J in Scotland) the boiler should be fitted in accordance with the manufacturer's instructions. Self-certification that the boiler has been installed to comply with Building Regulations can be demonstrated by completing and signing the Benchmark log book.

BENCHMARK LOG BOOK DETAILS

Boiler	Page	Page
Make and model	3	Burner operating pressure measure and record
Appliance serial no. on data badge	11	Central heating flow temp. measure and record
SEDBUK No. %	2	Central heating return temp. ... measure and record
Controls		For combination boilers only
Time and temperature control to heating	24	Scale reducer
Time and temperature control to hot water	24	Hot water mode
Heating zone valves	n/a	Heat input
TRV's	8	Max. operating burner pressure
Auto bypass	8	Max. operating water pressure
Boiler interlock	8	Cold water inlet temp
For all boilers		Hot water outlet temp. n/a
Flushing to BS.7593	10	Water flow rate at max. setting
Inhibitor	10	For condensing boilers only
Central heating mode		Condensate drain
Heat input	to be calculated	For all boilers: complete, sign & hand over to customer
		For assistance see Technical Helpline on the back page

NOTE TO THE INSTALLER: LEAVE THESE INSTRUCTIONS ADJACENT TO THE GAS METER. ALSO COMPLETE THE BENCHMARK LOG BOOK AND GIVE THIS TO THE CUSTOMER.



INTRODUCTION

The **icos system HE24** is a cast aluminium wall mounted, full sequence, automatic spark ignition, low water content, fanned flue, high efficiency, condensing system gas boiler.

Note. Due to the high efficiency of the boiler a plume of water vapour will form at the terminal during operation.

The output is fully modulating with a range of:

8.8 to 23.4 kW (30,000 to 80,000 Btu/h)

The boiler is supplied fully assembled with circulating pump, pressure gauge, safety valve and expansion vessel.

Variable temperature control is fitted on the user control.

The boiler casing is of white painted coated mild steel with the user controls capable of being mounted remotely from the boiler if the option is required.

The heat exchanger is of cast aluminium.

The boiler is suitable for connection to fully pumped, sealed water systems ONLY.

Adequate arrangements for completely draining the system by provision of drain cocks MUST be provided in the installation pipework.

Pipework from the boiler is routed downwards as standard, but may be routed upwards behind the boiler using the stand-off frame (supplied in a separate kit).

OPERATION

When there is a demand for heat, the heating system is supplied at the selected temperature of between 30°C and 82°C.

Refer also to Frame 1 - 'Boiler Water Circuit Diagram'

The boiler features a comprehensive diagnostic system which gives detailed information on the boiler status when operating, and performance of key components to aid commissioning and fault finding.

1 BOILER WATER CIRCUIT DIAGRAM

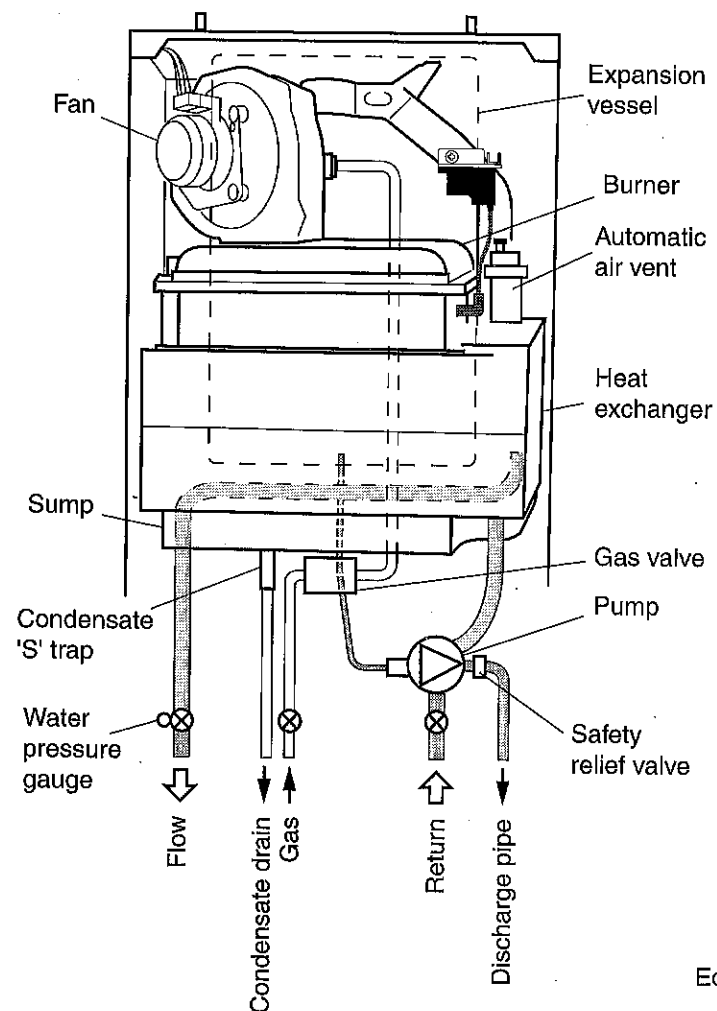

Ecl 2789

OPTIONAL EXTRA KITS

- **Flue Extension Ducts** (1000mm long, up to 6m).
- **Flue Finishing Kit**
- **90° Elbow Kit** (Maximum 4 elbows / installation).
- **45° Elbow Kit** (Maximum 4 elbows / installation).
- **Powered Vertical Flue Kit** (to a maximum primary flue length of 8m + a maximum secondary flue length of 6m)
- **Roof Flue Kit** (to a maximum of 8m).
- **Twin flueing Kit** (to a maximum of 46m combined total of flue and air ducts)
- **Remote User Controls Kit.**
- **Boiler Stand-off Kit.**
- **Siphon Kit.**
- **Valve Cover Kit.**

SAFETY

Current Gas Safety (Installation & Use) Regulations or rules in force.

The appliance is suitable only for installation in GB and IE and should be installed in accordance with the rules in force.

In GB, the installation must be carried out by a CORGI Registered Installer. It must be carried out in accordance with the relevant requirements of the:

- Gas Safety (Installation and Use) Regulations
- The appropriate Building Regulations either The Building Regulations, The Building Regulations (Scotland), Building Regulations (northern Ireland).
- The Water Fittings Regulations or Water byelaws in Scotland.
- The Current I.E.E. Wiring Regulations.

Where no specific instructions are given, reference should be made to the relevant British Standard Code of Practice.

In IE, the installation must be carried out by a Competent Person and installed in accordance with the current edition of I.S.813 "Domestic Gas Installations", the current Building Regulations and reference should be made to the current ETCI rules for electrical installation.

Detailed recommendations are contained in the following British Standard Codes of Practice:

- BS. 5440:1** Flues (for gas appliances of rated input not exceeding 70 kW).
- BS. 5440:2** Ventilation (for gas appliances of rated input not exceeding 70 kW).
- BS. 5449** Forced circulation hot water systems.
- BS. 5546** Installation of gas hot water supplies for domestic purposes (2nd Family Gases)
- BS. 6798** Installation of gas fired hot water boilers of rated input not exceeding 70 kW.
- BS. 6891** Low pressure installation pipes.

Health & Safety Document No. 635.

The Electricity at Work Regulations, 1989.

The manufacturer's notes must NOT be taken, in any way, as overriding statutory obligations.

IMPORTANT. These appliances are CE certificated for safety and performance. It is, therefore, important that no external control devices, e.g. flue dampers, economisers etc., are directly connected to these appliances unless covered by these Installation and Servicing Instructions or as otherwise recommended by **Caradon Ideal Limited** in writing. If in doubt please enquire.

Any direct connection of a control device not approved by **Caradon Ideal Limited** could invalidate the certification and the normal appliance warranty. It could also infringe the Gas Safety Regulations and the above regulations.

SAFE HANDLING OF SUBSTANCES

Care should be taken when handling the boiler insulation panels, which can cause irritation to the skin. No asbestos, mercury or CFCs are included in any part of the boiler or its manufacture.

LOCATION OF BOILER

The boiler must be installed on a flat and vertical wall, capable of adequately supporting the weight of the boiler and any ancillary equipment.

The boiler may be fitted on a combustible wall and insulation between the wall and the boiler is not necessary, unless required by the local authority.

For electrical safety reasons there must be no access available from the back of the boiler.

The boiler must not be fitted outside.

Timber Framed Buildings

If the boiler is to be fitted in a timber framed building it should be fitted in accordance with the Institute of Gas Engineering document IGE/UP/7:1998.

Bathroom Installations

This appliance is rated **IP20**.

The boiler may be installed in any room or internal space, although particular attention is drawn to the requirements of the current IEE (BS.7671) Wiring Regulations and, in Scotland, the electrical provisions of the building regulations applicable in Scotland, with respect to the installation of the boiler in a room or internal space containing a bath or shower. For Ireland reference should be made to the current ETCI rules for electrical installations and I.S.813:2002.

If the appliance is to be installed in a room containing a bath or shower then, providing water jets are not going to be used for cleaning purposes (as in communal baths/showers), the appliance can be installed in Zone 3, as detailed in BS.7671.

Compartment Installations

A compartment used to enclose the boiler should be designed and constructed specially for this purpose.

An existing cupboard or compartment may be used, provided that it is modified for the purpose.

In both cases, details of essential features of cupboard / compartment design, including airing cupboard installation, are to conform to the following:

- BS. 6798 (No cupboard ventilation is required - see 'Air Supply' for details).
- The position selected for installation MUST allow adequate space for servicing in front of the boiler.
- For the minimum clearances required for safety and subsequent service, see the wall mounting template and Frame 2. In addition, sufficient space may be required to allow lifting access to the wall mounting plate.

GENERAL

2 BOILER DIMENSIONS, SERVICES & CLEARANCES

all dimensions in mm (in)

The boiler connections are made on the boiler piping frame. Refer to Frames 20 & 21.

The following minimum clearances must be maintained for operation and servicing.

Additional space will be required for installation, depending upon site conditions.

Side and Rear Flue

a. Provided that the flue hole is cut accurately, e.g. with a core drill, the flue can be installed from inside the building

where wall thicknesses do not exceed 600mm (24"). Where the space into which the boiler is going to be installed is less than the length of flue required the flue must be fitted from the outside.

Installation from inside ONLY

b. If a core boring tool is to be used inside the building the space in which the boiler is to be installed must be at least wide enough to accommodate the tool.

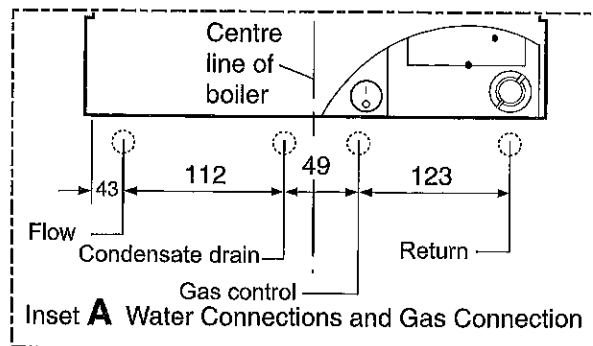
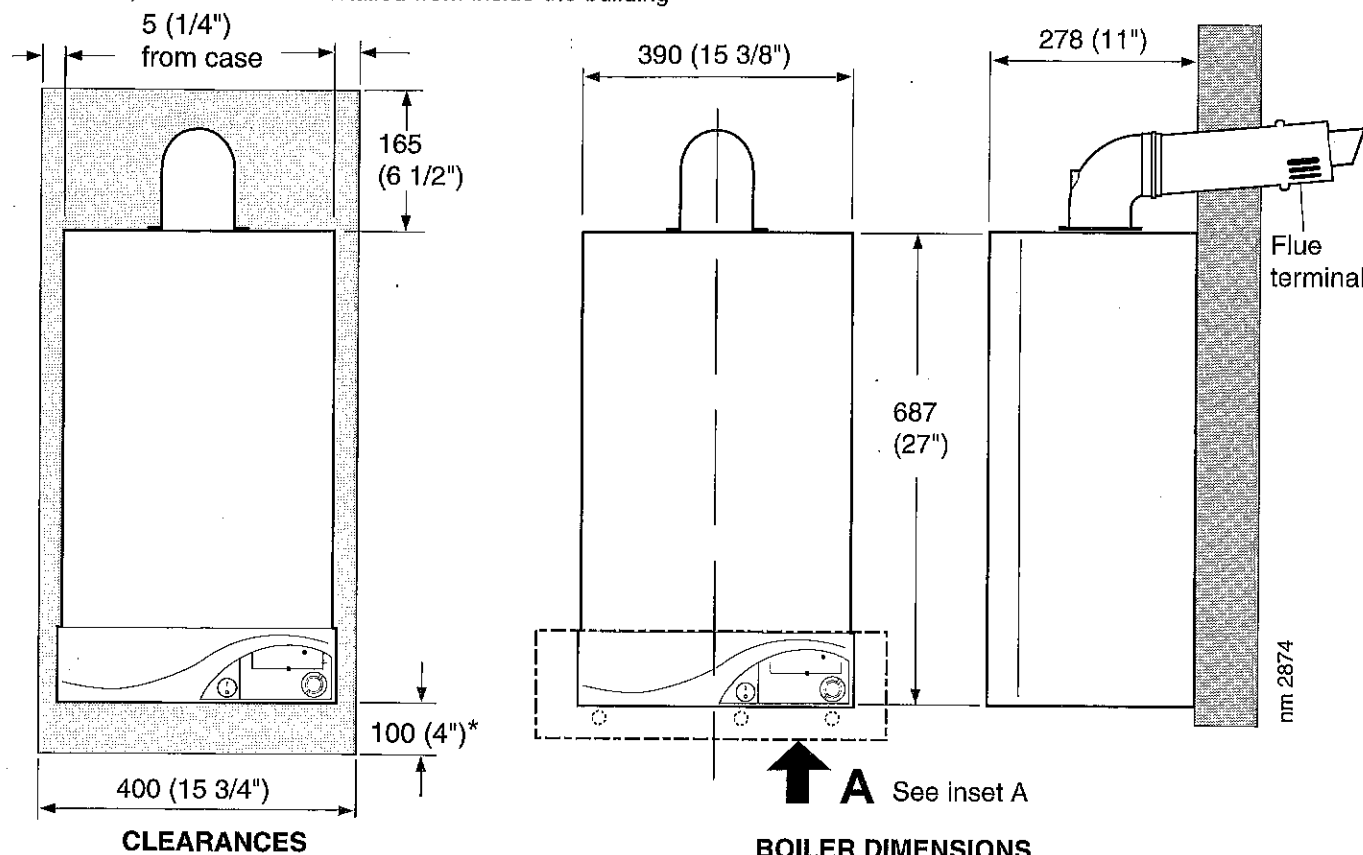

Front clearance

The minimum front clearance when built in to a cupboard is 5mm (1/4") from the cupboard door but 450mm (17 3/4") overall clearance is still required, with the cupboard door open, to allow for servicing.

N.B. The boiler will not fit into a standard depth wall unit. In order for it to do so the plastic fascia should be removed. See Frame 37.

* Bottom clearance

After installation can be reduced to 5mm in an adequately ventilated enclosed cupboard. However, 100mm must be available for servicing.

BOILER DIMENSIONS

SIDE FLUE ONLY	
Horizontal length of flue from centre line of boiler to outside wall	Top clearance required (MIN.) Dim. A
0.5 m	160 mm (6 5/16")
1.0 m	170 mm (6 11/16)
1.5 m	185 mm (7 1/4")
2.0 m	200 mm (7 7/8")
2.5 m	210 mm (8 1/4")
3.0 m	225 mm (8 7/8")
3.5 m	250 mm (9 7/8")
4.0 m	260 mm (10 1/4")
4.5 m	265 mm (10 7/16")
5.0 m	275 mm (10 13/16")
5.5 m	290 mm (11 3/8")
6.0 m	300 mm (11 13/16")

REARFLUE ONLY	
MIN. Top clearance required = 145 mm (5 3/4")	

GENERAL

GAS SUPPLY

The local gas supplier should be consulted, at the installation planning stage, in order to establish the availability of an adequate supply of gas. An existing service pipe must NOT be used without prior consultation with the local gas supplier.

The boiler MUST be installed on a gas supply with a governed meter only.

A gas meter can only be connected by the local gas supplier or by a CORGI registered engineer. In IE by a Competent Person.

An existing meter should be checked, preferably by the gas supplier, to ensure that the meter is adequate to deal with the rate of gas supply required.

N.B. The principle of the 1:1 gas valve ensures that the icos system HE24 is able to deliver its full output at inlet pressures well below those required by BS. 6891.

IMPORTANT.

Installation pipes MUST be fitted in accordance with BS.6891. In IE refer to I.S.813:2002. Pipework from the meter to the boiler MUST be of an adequate size, i.e. no longer than 20m and not less than 15mm O.D.

The complete installation MUST be tested for gas soundness and purged as described in the above code.

FLUE INSTALLATION

Plumbing will occur at the terminal, so where possible, terminal positions where this could cause a nuisance should be avoided.

The flue must be installed in accordance with the recommendations of BS.5440-1:2000. In IE refer to I.S.813:2002.

The following notes are intended for general guidance:

1. The boiler MUST be installed so that the terminal is exposed to external air.
2. It is important that the position of the terminal allows the free passage of air across it at all times.

Table 3 - Balanced Flue Terminal Position

Terminal Position	Minimum Spacing
1. Directly below or alongside an opening window, air brick or other ventilation opening	300 mm (12")
2. Below guttering, drain pipes or soil pipes	25mm (1")
3. Below eaves	25 mm (1")
4. Below balconies or a car port roof	25 mm (1")
5. From vertical drain pipes or soil pipes	25 mm (1")
6. From an internal or external corner or to a boundary along side the terminal.	25 mm (1")
7. Above adjacent ground, roof or balcony level	300 mm (12")
8. From a surface or boundary facing the terminal	600 mm (24")
9. From a terminal facing a terminal	1200 mm (48")
10. From an opening in a car port (e.g. door or window) into dwelling	1200 mm (48")
11. Vertically from a terminal on the same wall	1500 mm (60")
12. Horizontally from a terminal on the wall	300 mm (12")

3. Minimum acceptable spacing from the terminal to obstructions and ventilation openings are specified in Table 3.

4. Where the lowest part of the terminal is fitted less than 2m (6'6") above a balcony, above ground or above a flat roof to which people have access then the terminal MUST be protected by a purpose designed guard.

Terminal guards are available from boiler suppliers. (ask for TFC flue guard model no. K6 - round, plastic coated). In case of difficulty contact:

Grasslin (UK) Ltd., Tower House, Vale Rise, Tonbridge, Kent TN9 1TB
Tel: +44 (0) 1732 359 888. Fax: +44 (0) 1732 354 445
www.tfc-group.co.uk

Ensure that the guard is fitted centrally.

5. The flue assembly shall be so placed or shielded as to prevent ignition or damage to any part of any building.

6. The air inlet/products outlet duct and the terminal of the boiler MUST NOT be closer than 25mm (1") to combustible material. Detailed recommendations on the protection of combustible material are given in BS.5440-1:2000. In IE refer to I.S.813:2002.

IMPORTANT. It is absolutely essential to ensure, in practice, that products of combustion discharging from the terminal cannot re-enter the building or any other adjacent building through ventilators, windows, doors, other sources of natural air infiltration, or forced ventilation / air conditioning.

If this should occur the appliance MUST be turned OFF, labelled as 'unsafe' until corrective action can be taken.

TERMINAL

The terminal assembly can be adapted to accommodate various wall thicknesses. Refer to Frame 12.

AIR SUPPLY

It is NOT necessary to have a purpose-provided air vent in the room or internal space in which the boiler is installed. Neither is it necessary to ventilate a cupboard or compartment in which the boiler is installed, due to the low surface temperatures of the boiler casing during operation; therefore the requirements of BS.6798, Clause 12, and BS 5440:2 may be disregarded. In IE the requirements of I.S.813:2002 may be disregarded.

WATER CIRCULATION SYSTEM

IMPORTANT.

A minimum length of 1metre of copper pipe MUST be fitted to both flow and return connections from the boiler before connection to any plastic piping.

The central heating system should be in accordance with BS.6798 and, in addition, for smallbore and microbore systems, BS.5449.

The hot water storage cylinder MUST be of the indirect type and should preferably be made of copper.

Single feed, indirect cylinders MUST NOT be used. The appliances are NOT suitable for gravity central heating nor are they suitable for the provision of gravity domestic hot water.

The hot water cylinder and ancillary pipework, not forming part of the useful heating surface, should be lagged to prevent heat loss and any possible freezing - particularly where pipes run through roof spaces and ventilated underfloor spaces.

WATER TREATMENT - see Frame 6

GENERAL

The hydraulic resistance of the boilers, at MAXIMUM OUTPUT, with an 11°C (20°F) temperature differential, is shown in Graph 1.

Graph 1 - Water flow rate and pressure loss

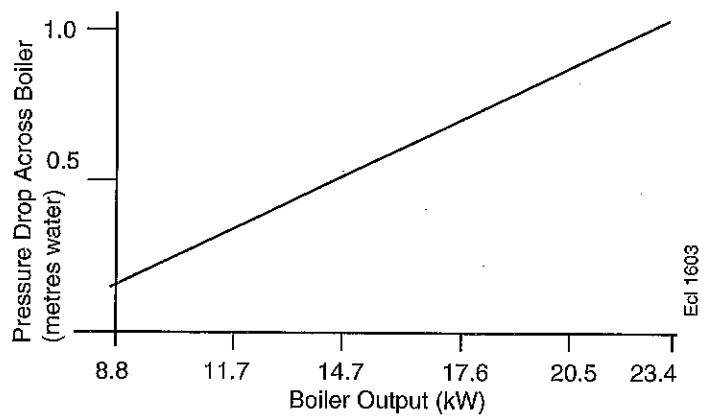

BOILER CONTROL INTERLOCKS

Caradon Ideal Limited recommend that heating systems utilising full thermostatic radiator valve control of temperature in individual rooms should also be fitted with a room thermostat controlling the temperature in a space served by radiators not fitted with such a valve as stated in BS. 5449.

When thermostatic radiator valves are used, the space heating temperature control over a living area having a heating requirement of at least 0.9kW (3000Btu/h) of the boiler heat output should be achieved using a room thermostat whilst other rooms are individually controlled by thermostatic radiator valves. A higher proportion of TRVs may be used, provided that

a bypass between the boiler flow and return is fitted, to ensure adequate flow when all TRVs are closed.

For further information refer to the 'Good Practice Guide 143', a publication of the Energy Efficiency Office, available from the Building Research Establishment, Garston, Watford WD2 7JR. Tel: +44 (0) 1923 664258.

ELECTRICAL SUPPLY

WARNING. The appliance MUST be efficiently earthed.

Wiring external to the appliance MUST be in accordance with the current I.E.E. (BS.7671) Wiring Regulations and any local regulations which apply. For Ireland reference should be made to the current ETCI rules for electrical installations.

The point of connection to the mains should be readily accessible and adjacent to the boiler.

CONDENSATE DRAIN - Refer to Frames 27 & 45

A condensate drain is provided on the boiler. This drain must be connected to a drainage point on site. All pipework and fittings in the condensate drainage system MUST be made of plastic - *no other materials may be used.*

IMPORTANT.

Any external runs must be insulated

The drain outlet on the boiler is standard 21.5mm (3/4") overflow pipe.

3 SYSTEM REQUIREMENTS

Notes

a. The method of filling, refilling, topping up or flushing sealed primary hot water circuits from the mains via a temporary hose connection is only allowed if acceptable to the local water authority.

b. Antifreeze fluid, corrosion and scale inhibitor fluids suitable for use with boilers having aluminium heat exchangers may be used in the central heating system.

Advice should be sought from a local water treatment company.

Safety valve setting	bar	3.0	
Vessel charge pressure	bar	0.5 to 0.75	
System pre-charge pressure	bar	None	1.0
System volume (litres)		Expansion vessel volume (litres)	
25		1.6	1.8
50		3.1	3.7
75		4.7	5.5
100		6.3	7.4
125		7.8	9.2
150		9.4	11.0
175		10.9	12.9
190		11.9	14.0
200		12.5	14.7
250		15.6	18.4
300		18.8	22.1
For other system volumes multiply by the factor across		0.063	0.074

GENERAL

4 SYSTEM REQUIREMENTS - continued

General

- The installation must comply with all relevant national and local regulations.
- The installation should be designed to work with flow temperatures of up to 82 °C.
- All components of the system must be suitable for a working pressure of 3 bar and temperature of 110 °C. Extra care should be taken in making all connections so that the risk of leakage is minimised.

The following components are incorporated within the appliance:

- Circulating pump.
- Safety valve, with a non-adjustable preset lift pressure of 3 bar.
- Pressure gauge, covering a range of 0 to 6 bar.
- An 8-litre expansion vessel, with an initial charge pressure of 0.75 bar.

- 'Make-up' Water. Provision must be made for replacing water loss from the system, either:

- From a manually filled 'make-up' vessel with a readily visible water level. The vessel should be mounted at least 150mm above the highest point of the system and be connected through a non-return valve to the system, fitted at least 150mm below the 'make-up' vessel on the return side of the radiators.

or

- Where access to a 'make-up' vessel would be difficult, by pre-pressurisation of the system.

The maximum cold water capacity of the system should not exceed 143 litres, if not pressurized. However, if the system is to be pressurized, the efficiency of the expansion vessel will be reduced and a larger vessel (or smaller system volume) may be necessary. If the capacity of the vessel is not considered sufficient for this, or for any other reason, an additional vessel MUST be installed on the return to the boiler.

Guidance on vessel sizing is given in Frame 3.

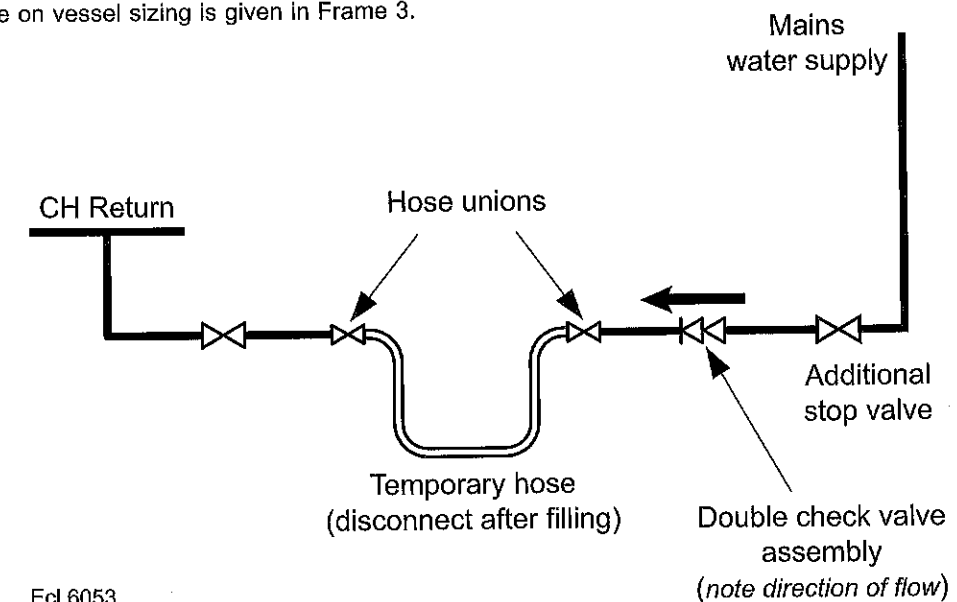

Ecl 6053

GENERAL

5 SYSTEM BALANCING

The boiler does not normally need a bypass but at least some radiators on the heating circuit, of load at least 10% of the minimum boiler output, must be provided with twin lockshield valves so that this minimum heating load is always available. See note regarding thermostatic radiator valves on page 8.

Note.

Systems incorporating zone valves which could completely cut off the flow through the system, must also include a bypass.

BALANCING

1. Set the programmer to ON, for both CH and DHW. Turn the cylinder thermostat down.

Close the manual or thermostatic valves on all radiators, leaving the twin lockshield valves (on the radiators referred to above) in the OPEN position.

Turn up the room thermostat and adjust these lockshield valves to give boiler flow and return temperatures not more than 20 °C apart.

These valves should now be left as set.

2. Open all manual or thermostatic radiator valves and adjust the lockshield valves on the remaining radiators, to give around 15 °C temperature drop at each radiator.
3. Turn up the cylinder thermostat and adjust the cylinder balancing valve so that the cylinder achieves a maximum flow consistent with adequate flow to the radiators. Check that with only the domestic hot water loop in circuit a differential temperature of 20 °C across the boiler is not exceeded.
4. Adjust the room and cylinder thermostat and programmer to NORMAL settings.

6 WATER TREATMENT

The icos system HE24 has an ALUMINIUM alloy heat exchanger.

IMPORTANT. The application of any other treatment to this product may render the guarantee of Caradon Ideal Limited INVALID.

Caradon Ideal Limited recommend Water Treatment in accordance with the Benchmark Guidance Notes on Water Treatment in Central Heating Systems.

Caradon Ideal Limited recommend the use of Fernox Copal or MB1, GE Betz Sentinel X100 or Salamander Corrosion Guard inhibitors and associated water treatment products, which must be used in accordance with the manufacturers instructions.

For further information contact:

Fernox Manufacturing Co. Ltd,
Cookson Electronics, Forsyth
Road, Sheerwater, Woking, Surrey,
GU21 5RZ.

Tel. +44 (0) 1799 521133 or

GE Betz Ltd,
Sentinel Division, Foundry
Lane, Widnes, Cheshire,
WA8 8UD.

Tel. +44 (0) 151 424 5351 or

Salamander Engineering Ltd, Unit 24,
Reddicap Trading Estate, Sutton
Coldfield, West Midlands
B75 7BU.

Tel. +44 (0) 121 378 0952

Notes.

1. It is most important that the correct concentration of the water treatment products is maintained in accordance with the manufacturers' instructions.
2. If the boiler is installed in an existing system any unsuitable additives MUST be removed by thorough cleansing. BS7593:1992 details the steps necessary to clean a domestic heating system.
3. In hard water areas, treatment to prevent limescale may be necessary - however the use of artificially softened water is NOT permitted.
4. Under no circumstances should the boiler be fired before the system has been thoroughly flushed.

7 BOILER ASSEMBLY - Exploded View Legend

- | | | | |
|-----------------------------|--------------------------|--------------------------------|---------------------------------|
| 1. Front casing panel. | 13. Heat exchanger | 25. Ignition electrode. | 57. CH return stub. |
| 2. Sealing panel. | 14. Injector & housing. | 26. Flame detection electrode. | 58. CH flow stub. |
| 3. Sump cover. | 15. Venturi assembly. | 32. Condensate 'S' trap. | 61. Pressure relief valve. |
| 4. Bottom casing panel. | 16. Fan assembly. | 35. User control. | 62. Expansion vessel. |
| 5. Flue sensing nipple. | 17. Automatic air vent. | 36. Primary controls (PCB). | 63. Expansion vessel pipe Assy. |
| 6. Return pipe. | 18. Gas service cock. | 39. Mains switch. | 64. Pressure gauge. |
| 8. Flue manifold. | 19. Gas control valve. | 44. Piping frame. | 69. Pump. |
| 9. Flue manifold fixing. | 20. Fan bracket. | 51. Mains connector. | 70. Pump manifold. |
| 10. Interpanel. | 21. Orifice plate. | 53. Turret gasket. | 75. Control box clamp. |
| 11. Burner. | 23. Control thermistor. | 54. Spark generator. | 103. Dry fire thermistor. |
| 12. Combustion chamber ins. | 24. Overheat thermostat. | 55. Ignition lead. | |

INSTALLATION

8 BOILER ASSEMBLY - Exploded View

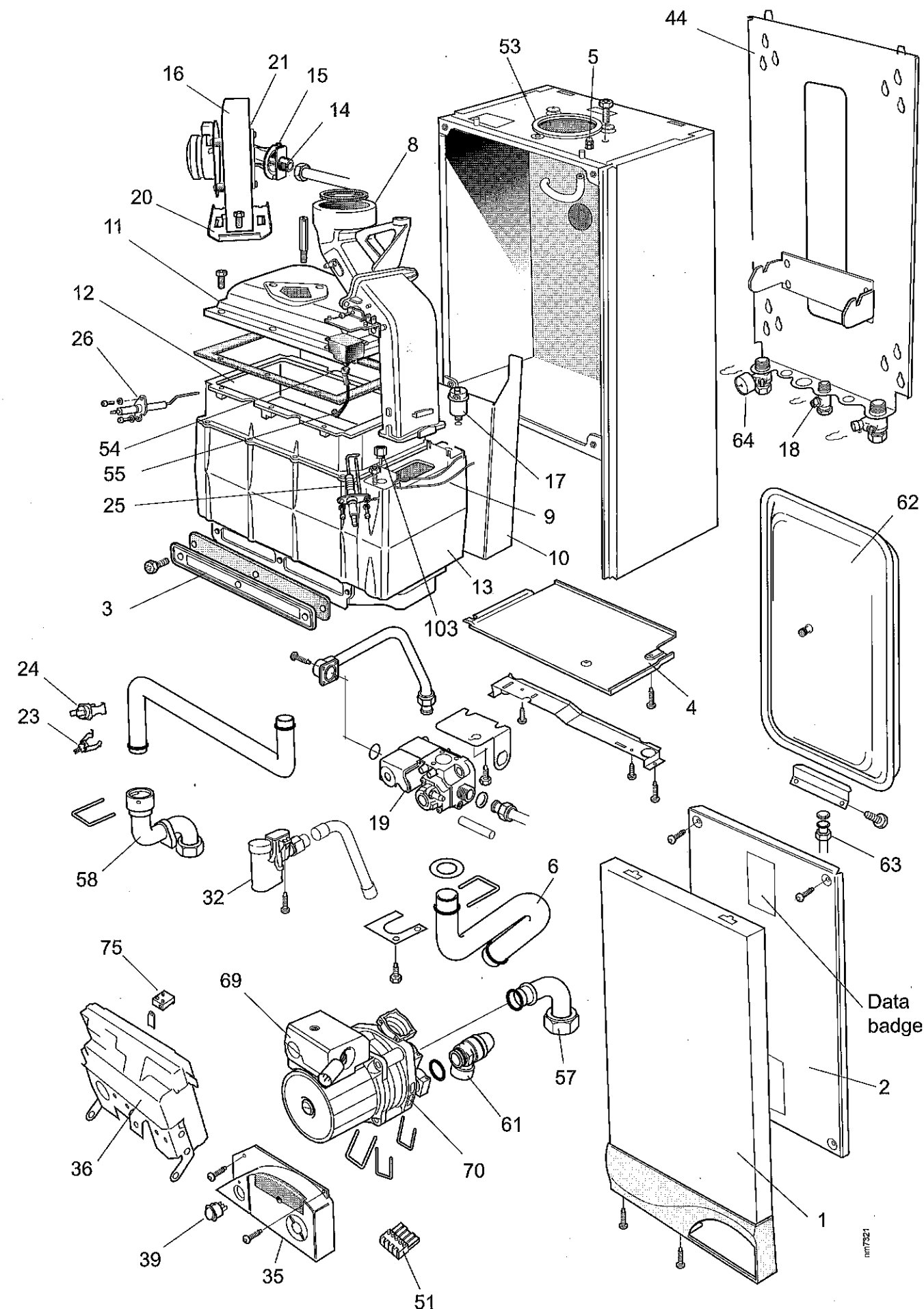

INSTALLATION

9 UNPACKING

The boiler is supplied fully assembled in one Pack A, together with a standard flue assembly for lengths up to 650mm, rear or side flue outlet, in Pack B.

Unpack and check the contents.

Note. The casing front plate panel and pre-piping frame are packaged together within a cardboard sleeved located within pack A. The casing front panel should not be fitted until the boiler is mounted on the wall. Failure to comply with this requirement may result in damage to the fascia.

Pack A Contents

- Hardware Pack & fittings.
- These Installation & Servicing Instructions.
- The User's Instructions.
- The User Control (Display unit).
- Benchmark log book.
- 1 Year guarantee form.

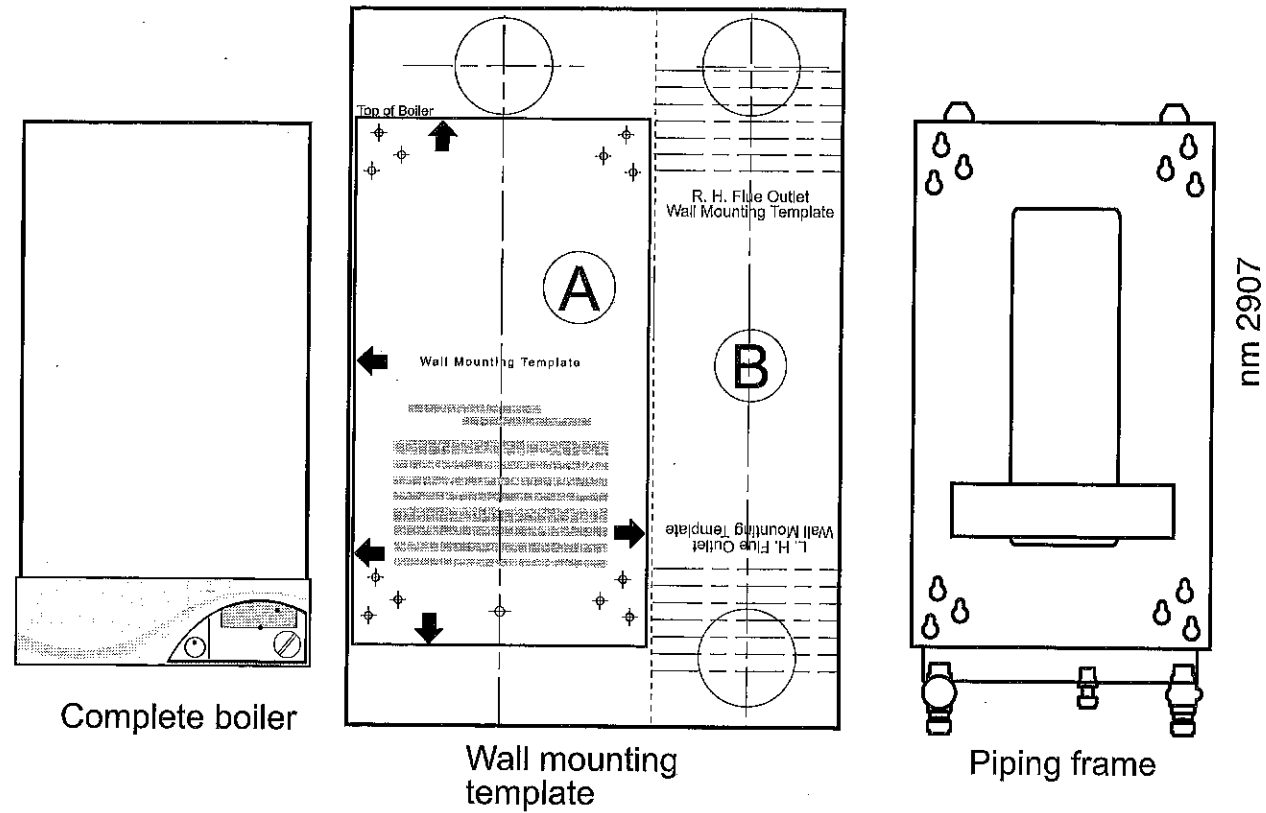

Hardware Pack & Fittings

- 50mm x No.14 wood screws - 4 off.
- Wall plugs (TP2B) - 4 off.
- Water treatment warning label.
- Turret clamp.
- M5 x 10 pozi Hex screw.
- 'S' Trap hose.
- Safety drain pipe nut and olive.
- Flow isolating valve c/w pressure gauge.
- 22mm fibre washers - 3 off.
- Mains connector.
- Push-in caps - 6 off.

Pack B Contents

- Flue turret.
- Flue terminal.
- Flue support cutting aid.

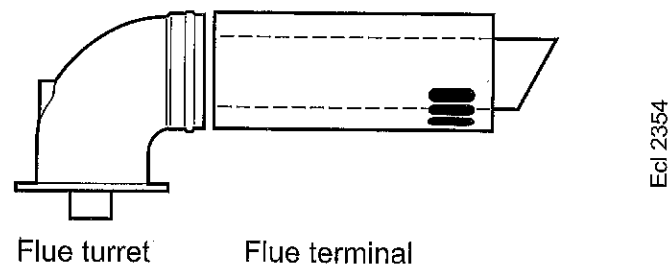

INSTALLATION

10 PACKAGING REMOVAL

1. Ensure the boiler is stood correctly, as marked on the carton.
2. Remove the strapping.
3. Fold back the top flaps to gain access to:
 - Wall mounting plate.
 - Instructions.
 - Hardware pack & fittings.
 - User control.
 - Pre-piping frame
4. Remove the instructions and read thoroughly before unpacking the product.
5. When ready for installation lift off the cardboard carton.

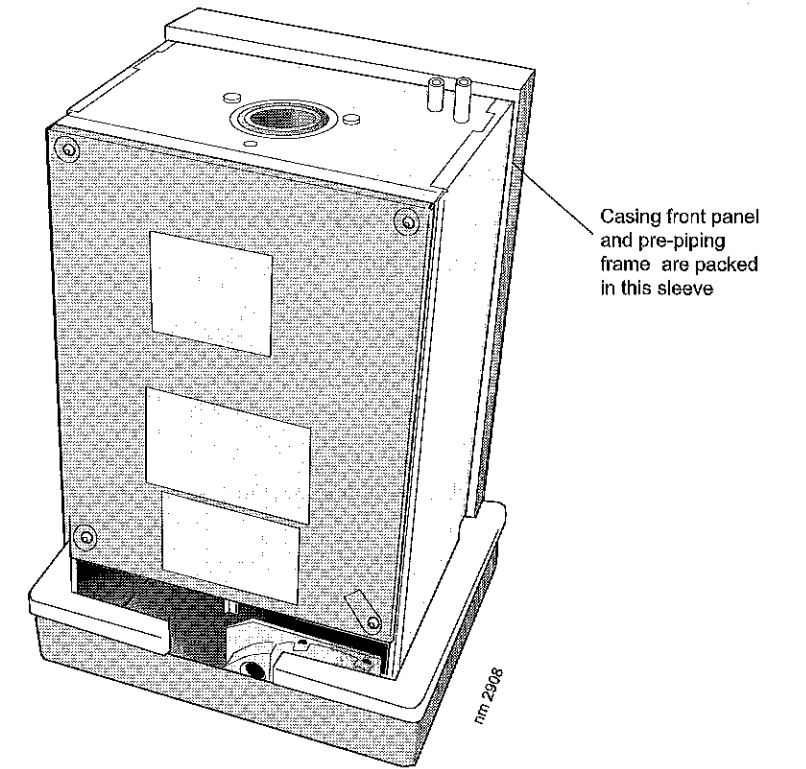

11 BOTTOM PANEL REMOVAL

1. Unscrew and remove the screws from the underside of the boiler.
2. Pull the RHS of the panel down, slide it to the right and withdraw.

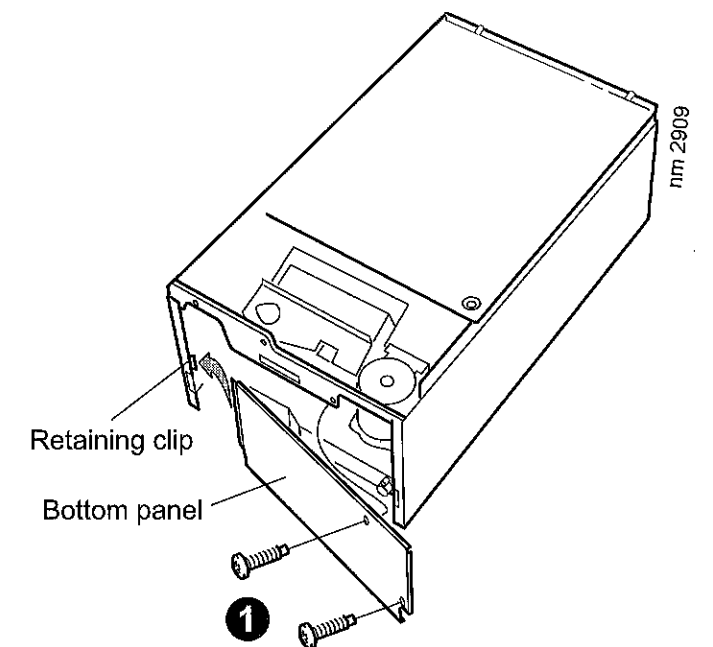

INSTALLATION

12 DETERMINING THE FLUE LENGTH AND FLUE PACKS REQUIRED

IMPORTANT. The boiler MUST be installed in a vertical position

Dimension X - Wall thickness.

Dimension L - Wall thickness plus boiler spacing .

Dimension S - Stand-off frame depth = 33mm.

FLUE KITS

Pack B - supplied as standard

Pack D - optional extension kit for side flue or rear flue outlet.

Refer to 'Flue Extension Ducts'

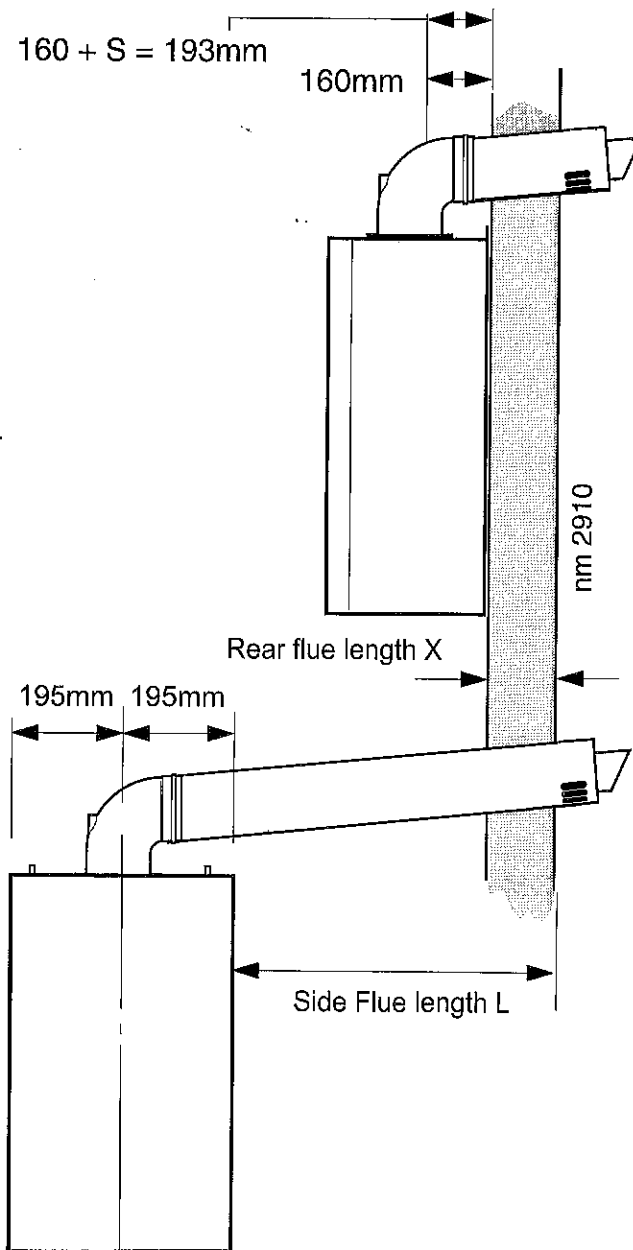

Total Flue length dimension		Flue
Rear flue dim. X+160	Side flue dim. L+195	Extra packs required
Up to 650 mm	Up to 650 mm	none
Up to 1600 mm	Up to 1600 mm	Pack D - 1 off
Up to 2550 mm	Up to 2550 mm	Pack D - 2 off
Up to 3500 mm	Up to 3500 mm	Pack D - 3 off
Up to 4450 mm	Up to 4450 mm	Pack D - 4 off
Up to 5400 mm	Up to 5400 mm	Pack D - 5 off
Up to 6000 mm	Up to 6000 mm	Pack D - 6 off

Notes.

- The flue duct **MUST** be inclined at 1.5 degrees to the horizontal to allow condensate to drain back into the boiler and out through the condensate drain.
- If the boiler is to be installed with upward piping routed behind the boiler then the optional stand-off kit should be used. Care must be taken when cutting the ducts and marking the wall to suit this condition.

INSTALLATION

13 FLUE ASSEMBLY - Exploded View

An optional flue duct extension kit is required for wall thicknesses greater than :

Side 455mm (18").

Rear 490mm (19 1/4").

LEGEND

- Duct assembly.
- Flue Turret.
- Turret gasket.
- M5 x 10 pozi screw.
- Turret clamp.

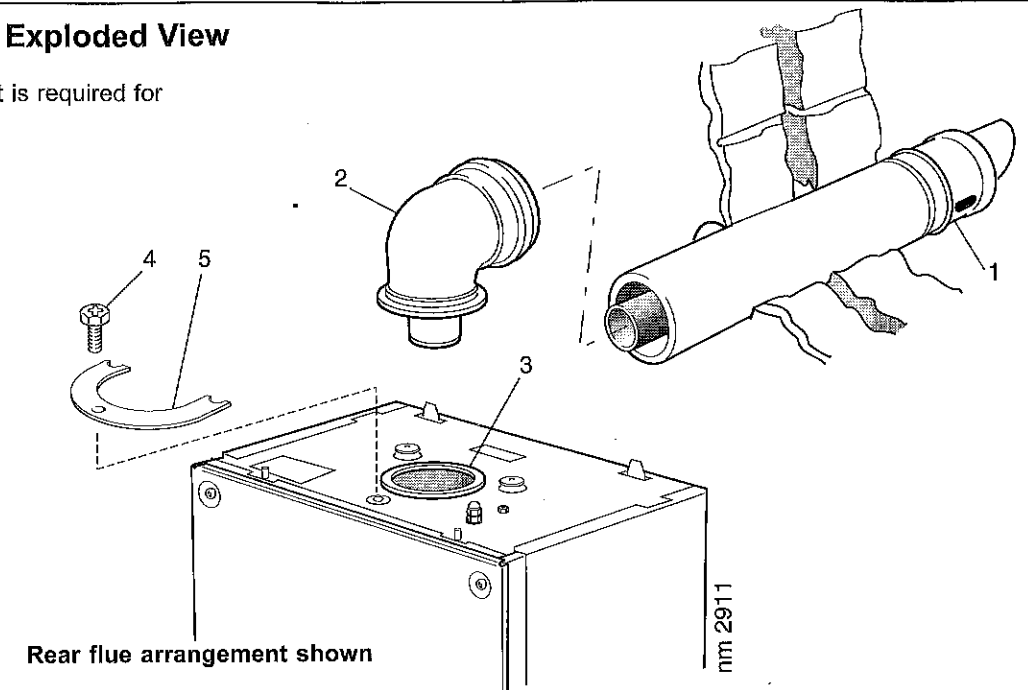

14 WALL MOUNTING TEMPLATE

Note.

The template shows the positions of the fixing holes and the flue hole centres for standard installation and for using the stand-off kit. Care **MUST** be taken to ensure the correct holes are drilled.

- Separate the templates.
 - Tape template A into the selected position.
 - Ensure squareness by hanging a plumbline as shown. If fitting a side flue extend the flue centre line onto the side wall. Tape template B into the selected position.
 - Mark onto the wall the following:
 - The piping frame screw positions (choose one from each group).
 - The position of the flue duct hole (see diagram below and template).
- Note.** Mark the centre of the hole as well as the circumference
- Remove the template from the wall.

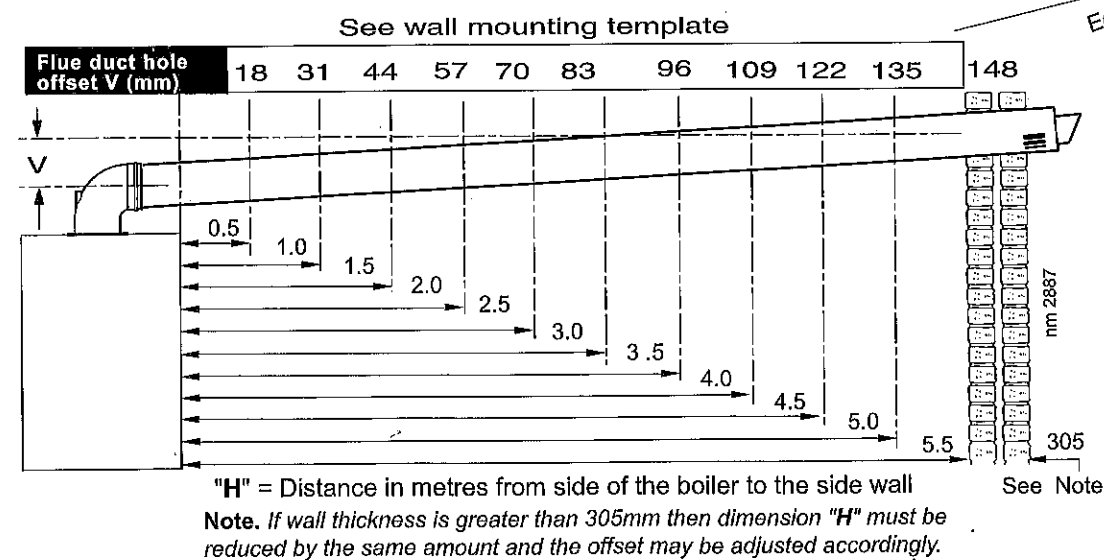
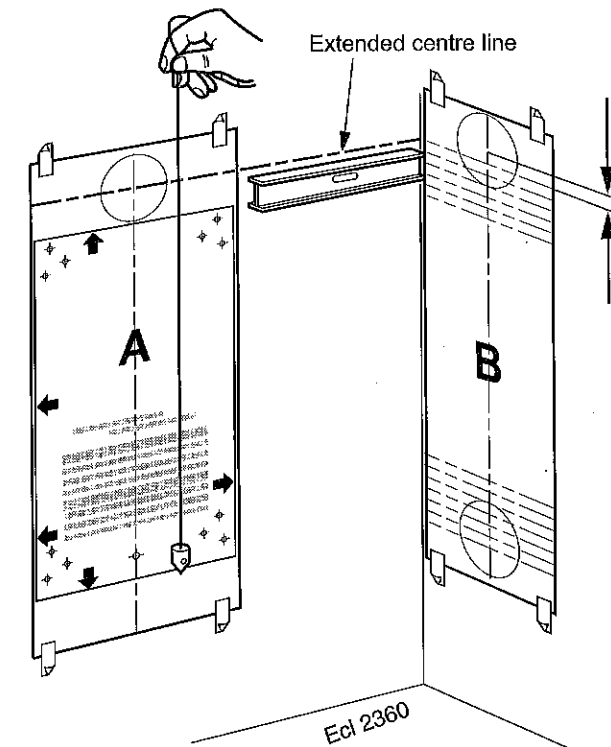

INSTALLATION

15 PREPARING THE WALL

IMPORTANT.

Ensure that, during the cutting operation, masonry falling outside of the building does not cause damage or personal injury.

1. Cut the flue hole (preferably with a 5" core boring tool), ensuring that the hole is square to the wall. Both wall faces immediately around the cut hole should be flat.
2. Drill 4 holes with a 7mm (1/4") masonry drill and insert the plastic plugs provided, for the piping frame.
3. Locate 4 No.10 x 2" screws in the piping frame (one at each side, in any of the 3 holes provided at each side) and screw home.

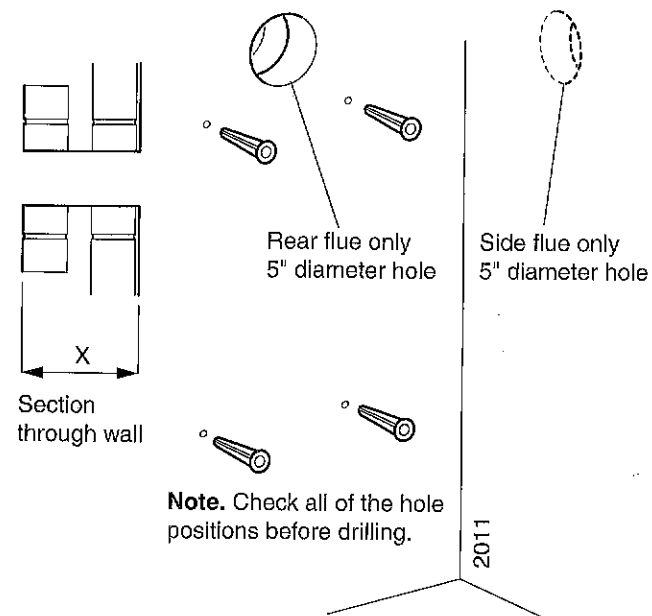

16 CUTTING THE FLUE - REAR Wall thicknesses of 114 to 490mm

Notes.

- a. If using the extension ducts go to Frame 18.
- b. If the stand-off frame is used it is essential add 33mm to X, the measured wall thickness, when marking the flue (this will allow for the fitted frame).

1. Measure and note wall thickness X. Refer to Frame 12.
2. Add 90mm (3 1/2") to dimension X and, measuring from the ring, cut the outer tube only.
3. To ensure the tube is cut square, mark the flue all the way around.
4. Cut the inner tube to a length 20mm (3/4") longer to aid engagement, using the cardboard support.

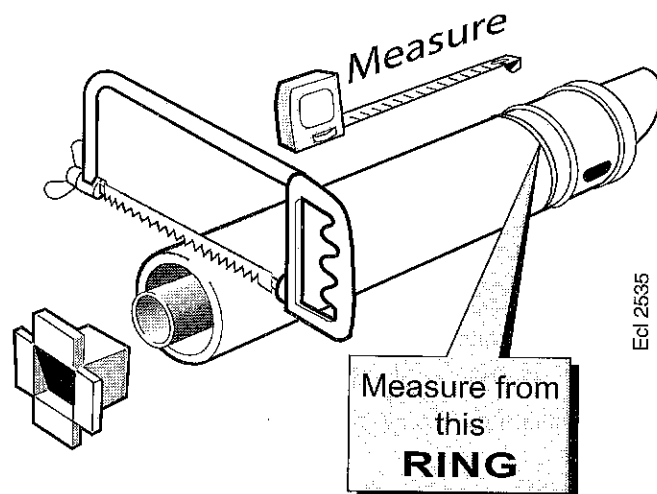

17 CUTTING THE FLUE - SIDE Wall thicknesses of 114 to 455mm

Note. If using the extension ducts go to Frame 18.

1. Measure and note side flue length L. Refer to Frame 12.
2. Add 125mm (5") to dimension L and, measuring from the ring, cut the outer tube only.
3. To ensure the tube is cut square, mark the flue all the way around.
4. Cut the inner tube to a length 20mm (3/4") longer to aid engagement, using the cardboard support.

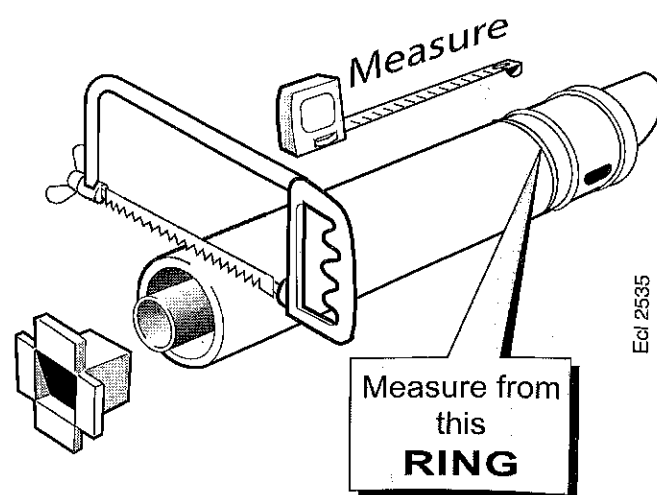

INSTALLATION

18 FLUE EXTENSION DUCTS - For flue lengths greater than 650mm

Pack D Flue extension duct kit contents.

Extension duct & clamp
1.0m (39") long

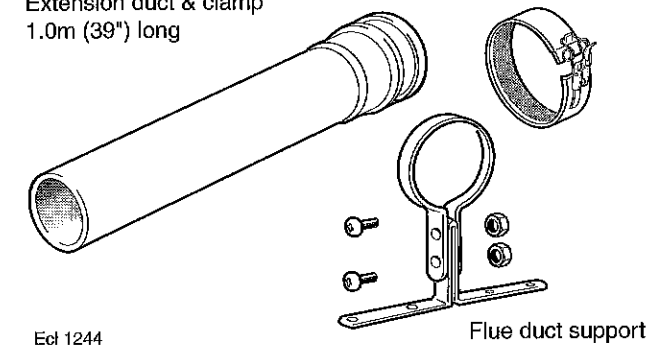

Flue support cutting aid
(shown folded up)

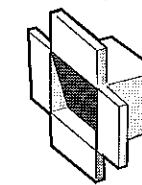

Wall plugs - 4 off

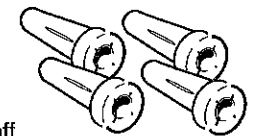

No. 10 x2" wood screw - 4 off

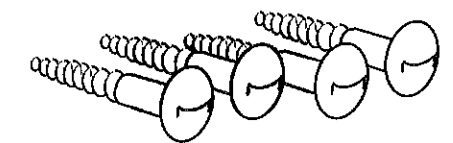

19 FLUE EXTENSION DUCTS - continued

Use a maximum of 6m extended flue ONLY

General arrangement

1. A **maximum** of 6 extension ducts (one suitably cut) plus the standard flue duct may be used together.
2. Flue extensions of greater length than 1m (39") should be supported with the bracket provided, suitably adjusted. Refer to Frames 18 & 23.

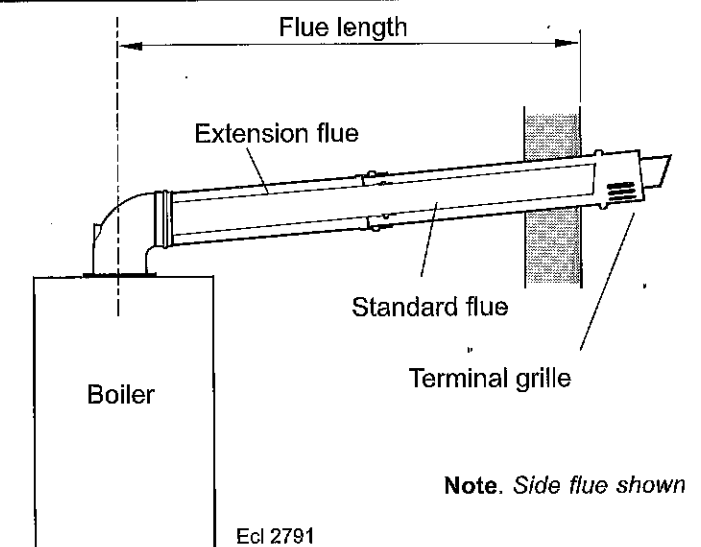

20 FITTING THE KIT

1. Remove the cardboard support aid from the flue and place safely to one side.
2. Fit the inner flue extension duct onto the inner flue duct.
3. Fit the outer flue extension duct onto the outer air duct.
4. Using the clamp provided clamp the flue lengths together.
5. Repeat steps 1-4 if a second flue extension is required.
6. Measure and mark the flue length required onto the flue, measuring from the ring near the terminal.
7. To ensure a square cut, mark the flue all the way around.
8. Cut to length using the cardboard support aid.
9. Remove the cardboard and deburr the metal edges.

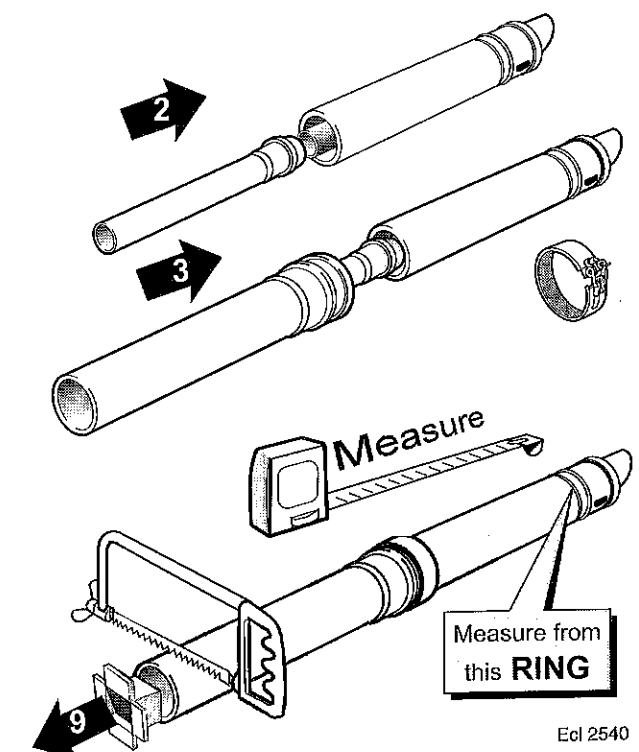

INSTALLATION

21 FITTING THE PIPING FRAME (Rear Flue outlet shown)

Note. The flow isolating valve (A), c/w pressure gauge, is supplied separately in the hardware pack. Fit to the piping frame BEFORE mounting the boiler.

Fit the wall mounting frame either:

a. Directly to the wall

- Insert wall plugs.
- Put the screws into the wall plugs and leave 10mm proud
- Hang the frame onto the screws (take care to use the same hole position from each group as previously chosen with the wall template) and tighten up.
- Locate the support bracket on the piping frame.

or

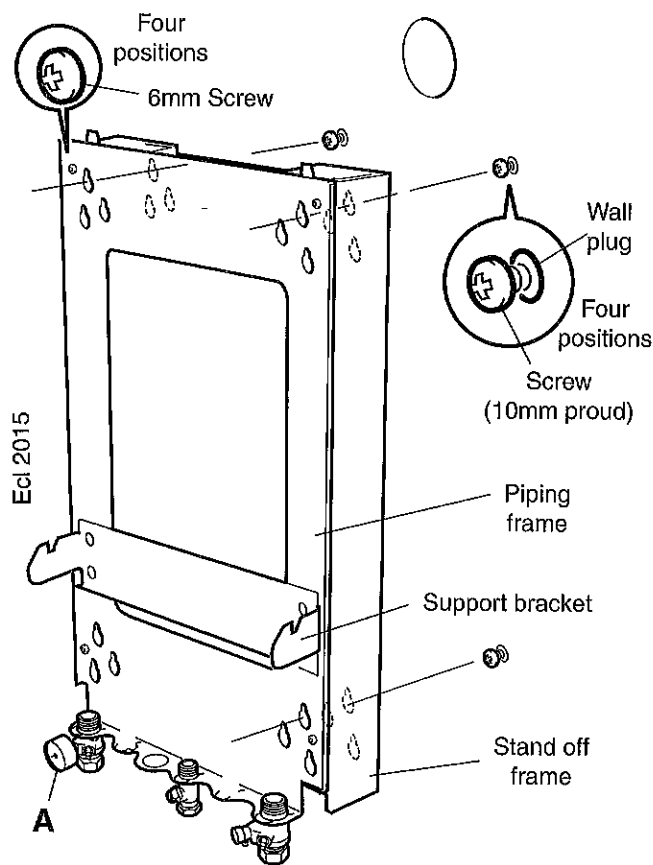
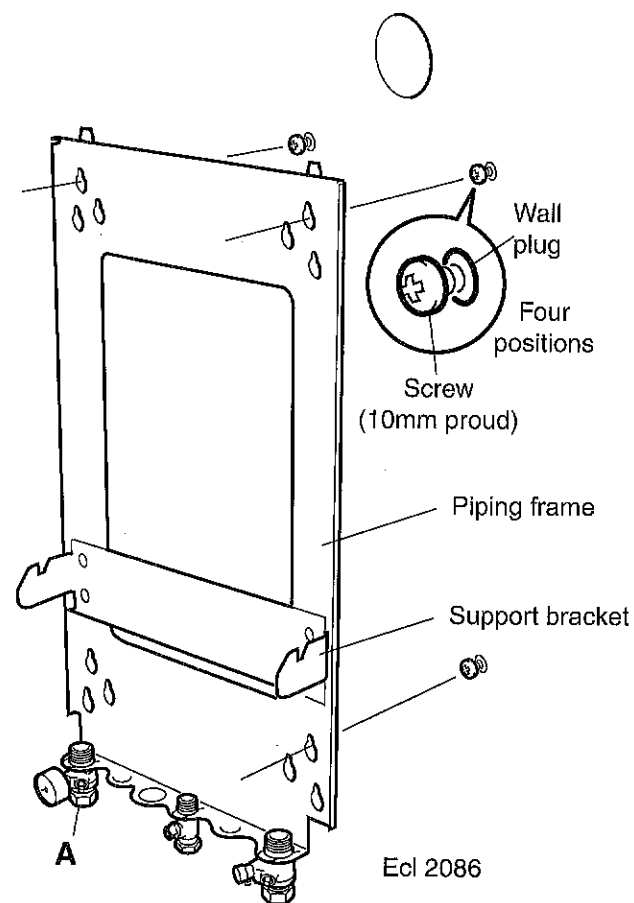

b. Use the stand-off frame

(To allow pipework to be taken upwards).

- Insert wall plugs.
- Put the screws into the wall plugs and leave 10mm proud.
- Hang the stand-off frame onto the screws and tighten up.
- Fasten the piping frame to the stand-off frame with the 6mm screws and washers provided.
- Locate the support bracket on the piping frame.

Note. If the clearances above and below the boiler are less than the length of the pipes it will be necessary to position the pipes behind the wall mounting plate BEFORE the plate is screwed to the wall.

Service connections may be made now, before mounting the boiler, if required. Refer to Frames 24 & 25.

INSTALLATION

22 CONDENSATE DRAIN

Refer also to the British Gas document: 'Guidance Notes for the Installation of Domestic Gas Condensing Boilers' (1989).

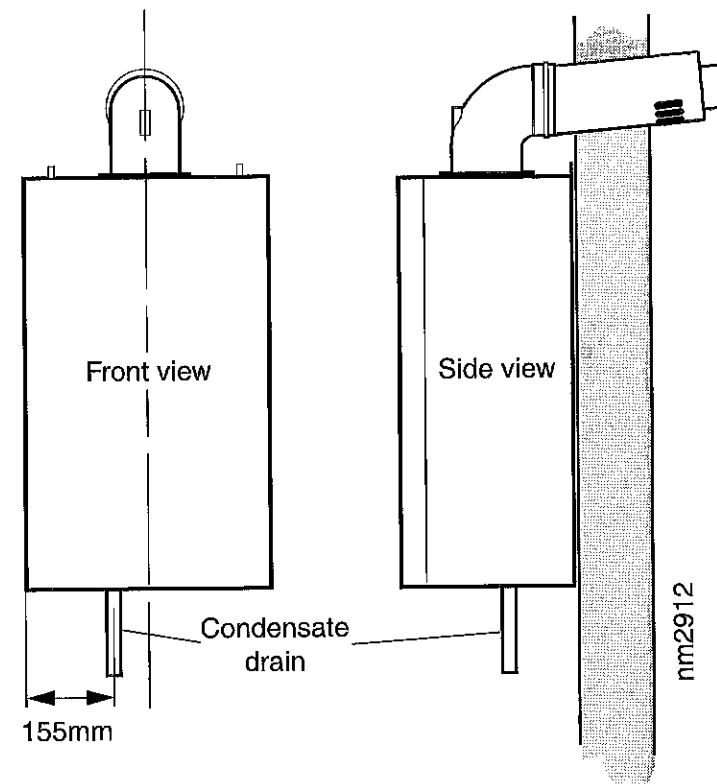

The condensate drain (provided in the h/ware pack) must be connected from the boiler 'S' trap to a drainage point, preferably within the building.

Ensure that the condensate trap is full of water before commissioning the boiler. Refer to Frame 23.

The routing of the drain must be made to allow a minimum fall of 1 in 20 away from the boiler, throughout its length.

The drainage pipework must be arranged so that obstruction (e.g. through freezing) of external drainage pipe does not give rise to spillage within the dwelling.

IMPORTANT.

If excessive external pipework cannot be avoided, an additional siphon kit and insulation are recommended, in order to prevent possible freezing.

All pipework and fittings in the condensate drain system must be made of plastic. No other materials may be used.

The drain outlet on the boiler is standard 21.5 mm overflow pipe. This size must not be reduced in any part of its length.

23 MOUNTING THE BOILER

IMPORTANT.

Before mounting the boiler on the wall fit the 'S' trap hose moulding/nut.

1. Ensure that the plastic plugs are removed from both the pipes before mounting. **N.B.** Some spillage of water may occur from the pipework when mounting the boiler to the frame.
2. Lift the boiler onto the wall mounting frame, locating it over the tabs at the top of the frame.
3. Lower the boiler into position, engaging it onto the support bracket.

Note. Ensure the condensate drain pipe is correctly positioned before continuing.
4. Using the fibre washers supplied in the hardware pack, engage and then tighten the 2 water unions.
5. Engage and tighten the gas union, ensuring that the rubber seal is in place. **DO NOT** overtighten.
6. Connect a pipe to the safety drain outlet using the nut and olive supplied in the boiler hardware pack.
7. Plug the user control (display unit, Pack A) into the control box. Refer to Frame 35.
8. Screw the user control into position.

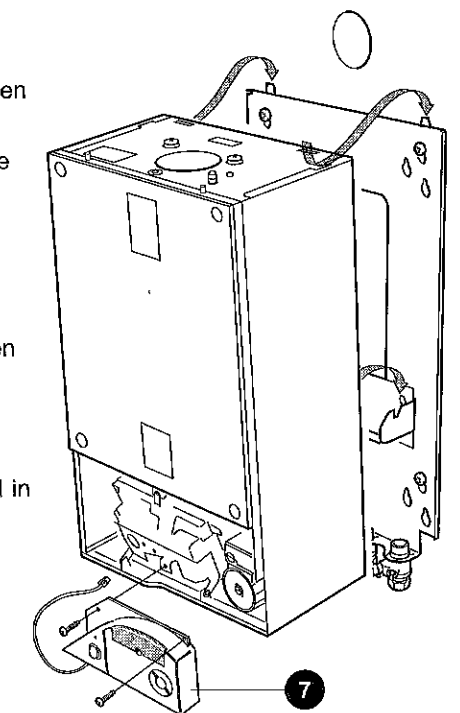

INSTALLATION

24 CONNECTING THE FLUE TO THE BOILER

Note. Before fitting the flue turret fill the condensate trap within the boiler by pouring a cupful of water into the flue outlet A. Take care to ensure that the water is only poured into the flue outlet, and does not spill into the boiler casing.

1. Insert the flue assembly through the prepared hole in the wall.
2. Locate the flue turret on the top of the boiler, ensuring that the turret gasket is in place. Check that the flue 'A' seal located in the top of the flue manifold is secure and giving an effective seal.
3. Locate the flue into the turret.
4. Secure the flue turret on top of the boiler by inserting the open ends of the turret clamp under the 2 studs and fixing it in the middle with the single M5 x 10mm pozi-hex screw provided.

5. Flues over 1 metre long.

Fix the flue support bracket to the wall, using the wall plugs and wood screws.

NB. The support bracket will utilise one fixing hole only whilst used in conjunction with the stand-off option.

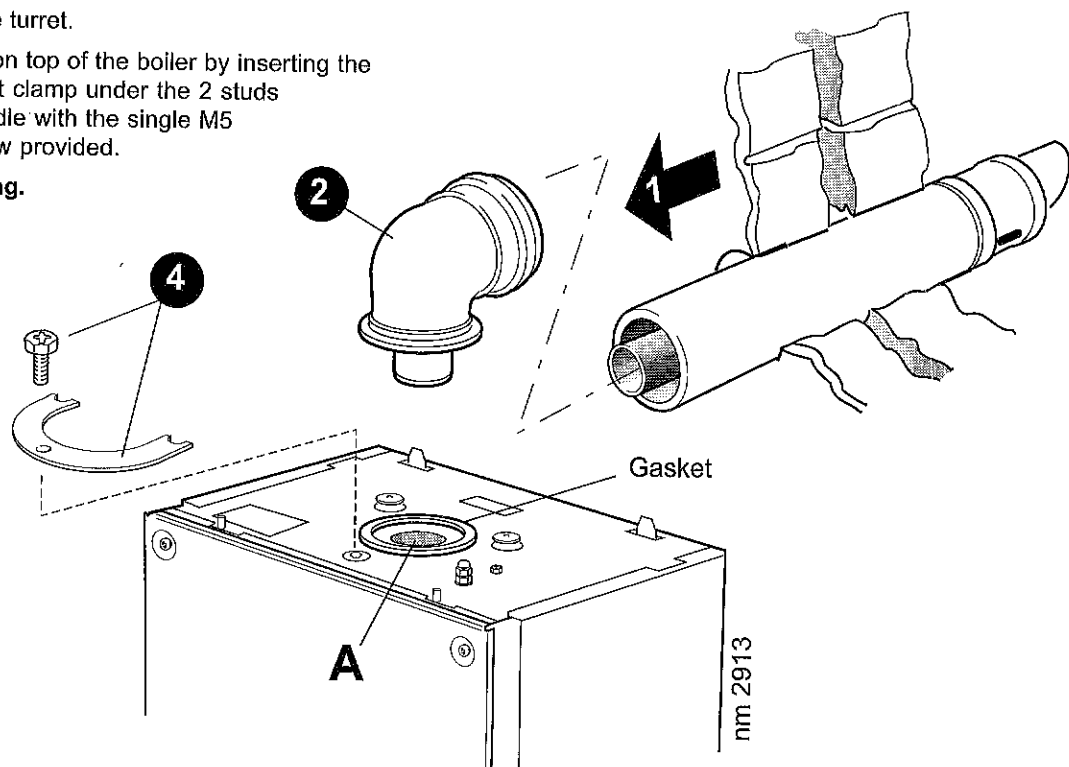

25 GAS CONNECTION

IMPORTANT. The gas service cock is sealed with a non-metallic fibre washer so must not be overheated when making capillary connections.

Refer to Frame 2 for details of the position of the gas connection.

The principle of the 1:1 gas valve ensures that the **icos system HE24** is able to deliver its full output at inlet pressures well below those required by BS. 6891.

A boiler gas supply pipe length of 20m and not less than 15mm O.D. can be connected to the boiler via the gas service cock union.

Ensure that the gas supply pipe does not foul the boiler casing.

Refer to Frame 35 or 'Servicing' for details of the pressure test point position.

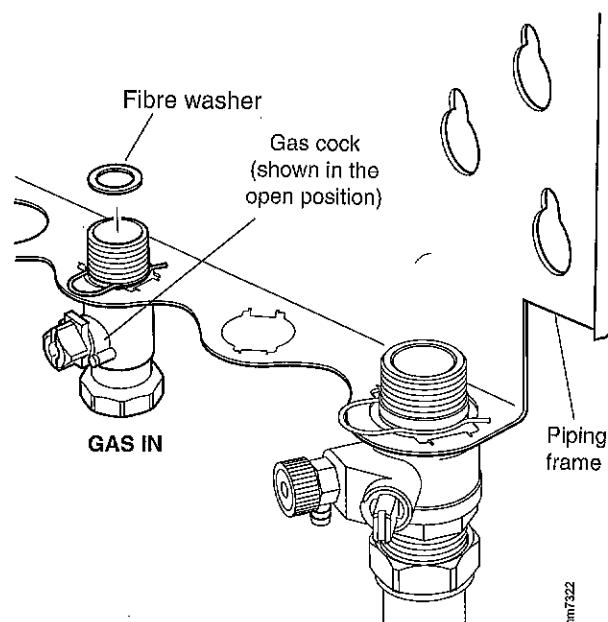

INSTALLATION

26 SAFETY VALVE DRAIN

The safety valve is located at the bottom RHS of the boiler.

The discharge pipe should be positioned so that the discharge of water or steam cannot create a hazard to the occupants of the premises or damage the electrical components and wiring.

27 WATER CONNECTIONS

Notes.

1. For heating loads in excess of 60,000 Btu/h use 28mm x 22mm connectors to connect the boiler flow and return pipes to 28mm system pipework.
2. Do not subject any of the isolating valves to heat as the seals may be damaged.

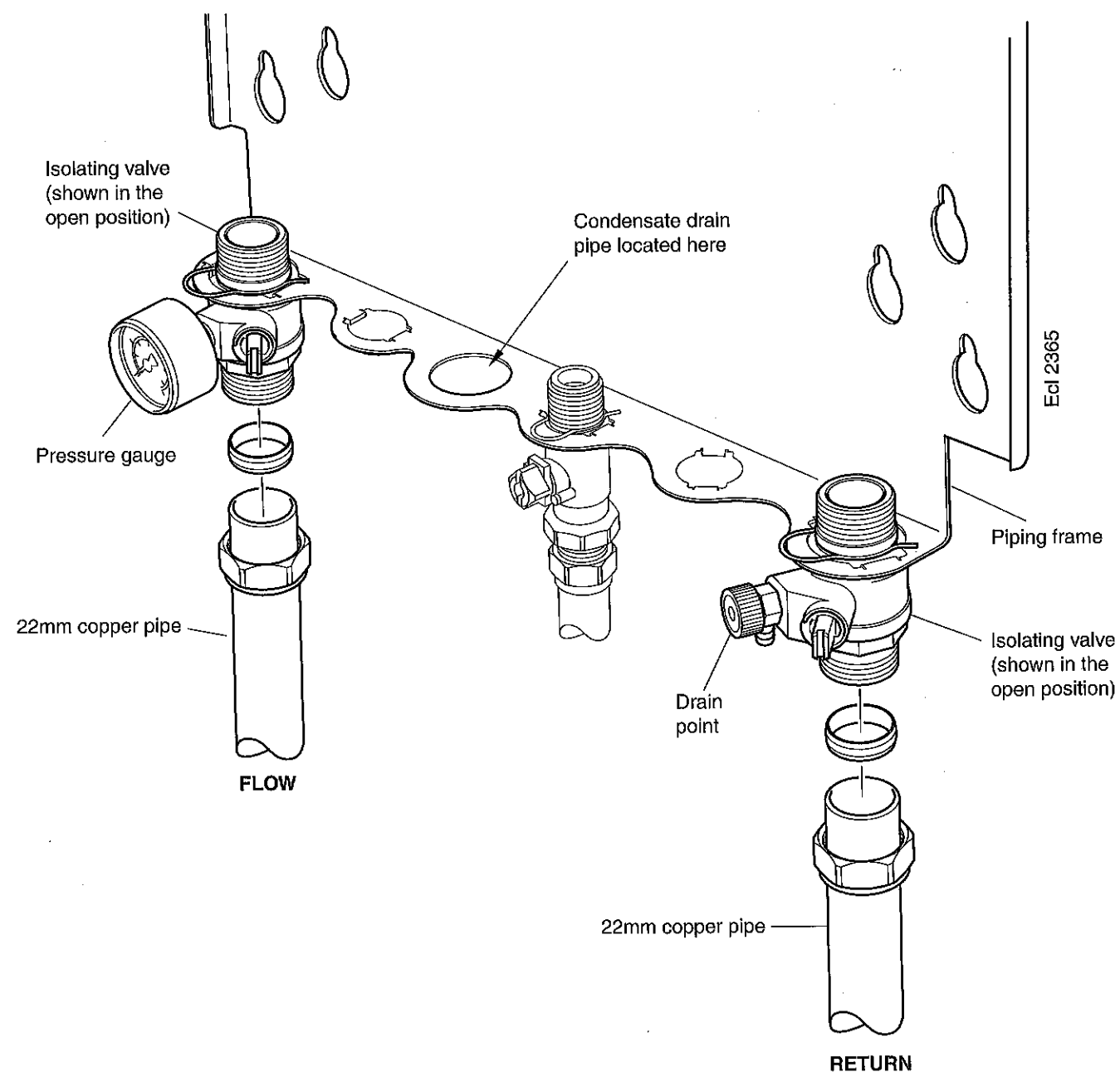

INSTALLATION

28 FILLING

1. Remove the boiler front and sealing panels. Refer to Frames 40 & 41.
2. Swing the control box down into the servicing position - Refer to Frame 42.
3. Ensure that the isolating valves are open.
4. Fill and vent the system. Check for water soundness.

IMPORTANT - when filling:

- a. When filling, there may be a slight water leak from the vent therefore electrical connections should be protected.
- b. Bleed any air from the pump and ensure that it is free to rotate.
 - i. Remove the vent plug
 - ii. Using a screwdriver, rotate the shaft several times
 - iii. Replace the vent plug.

Note. Some slight water leakage will occur.

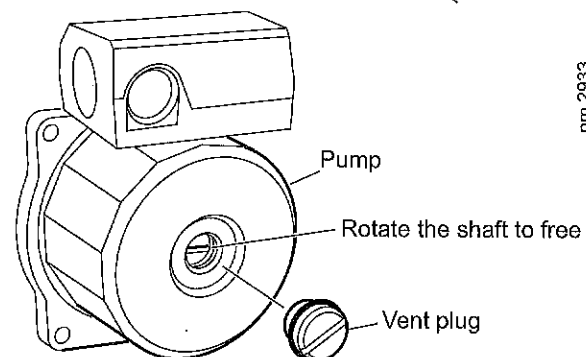
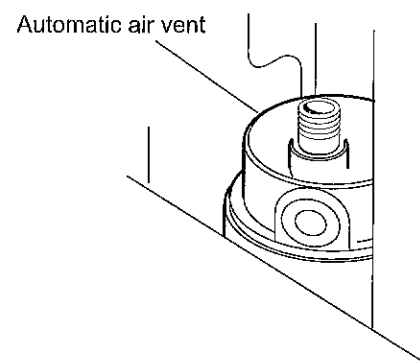

nm 2933

INSTALLATION

29 ELECTRICAL CONNECTIONS

WARNING. This appliance MUST be earthed.

A mains supply of 230 V ~ 50 Hz is required.

The fuse rating should be 3A.

All external controls and wiring must be suitable for mains voltage.

Wiring external to the boiler MUST be in accordance with the current I.E.E. (BS.7671) Wiring Regulations and any local regulations.

Wiring should be 3 core PVC insulated cable, not less than 0.75 mm² (24 x 0.2mm), and to BS 6500 Table 16. For IE reference should be made to the current ETCI rules for electrical installations.

Connection must be made in a way that allows complete isolation of the electrical supply such as a double pole switch having a 3mm (1/8") contact separation in both poles, or a plug and socket, serving only the boiler and system controls. The means of isolation must be accessible to the user after installation.

30 INTERNAL WIRING

A pictorial wiring diagram is shown in Frame 32.

1. Route the mains cable into the bottom rear centre of the boiler.
2. Wire the permanent live supply into the 5-way remote plug terminals, L3, N & \perp .

IMPORTANT. The permanent live is ESSENTIAL in order for the advanced diagnostic controls to function correctly.

3. Wire the switched live supply into terminal L2 or connect L1 and L2 via external control switching, as shown in Frame 31. In either case, remove the wire link fitted to L1 and L2.
4. Secure the mains lead with the cable clamp.
5. Connect the mains lead connector. Ensure it is fully located.

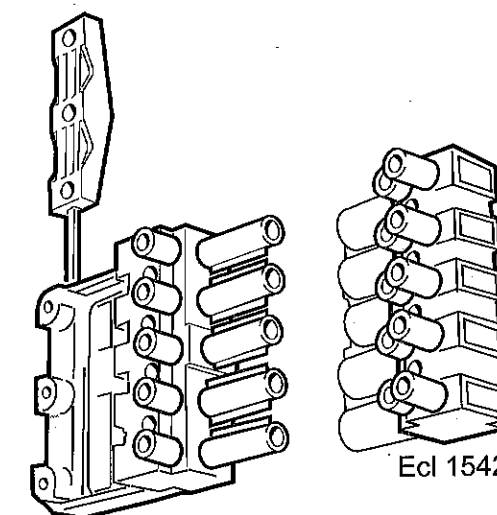

Note.

Ensure that the lengths of the current carrying conductors are shorter than the earth conductor so that if the cable slips in its anchorage the current carrying conductors become taut before the earth conductor.

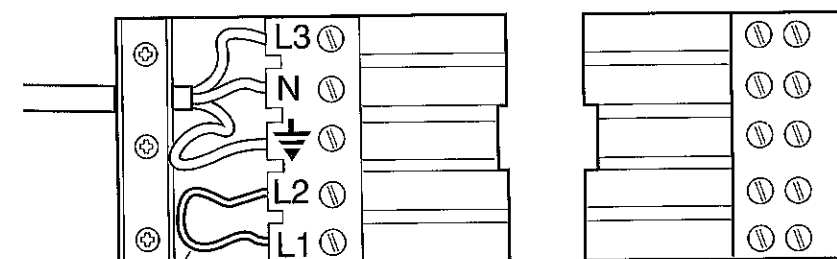

Remove link when connecting external programmer.

Mains Connector
(supplied in hardware pack)

Socket
(fixed to boiler)

Ecl2367

INSTALLATION

31 EXTERNAL ELECTRICAL CONTROLS

Wiring external to the boiler MUST be in accordance with the current I.E.E. (BS.7671) Wiring Regulations and any local regulations. For IE reference should be made to the current ETCI rules for electrical installations.

The fuse rating should be 3A.

Room Thermostat

If the thermostat has a neutral connection, use it (it provides for more energy efficient operation by reducing switching temperature differentials).

Frost Protection

If parts of the pipework run outside the house or if the boiler will be left off for more than a day or so then a frost thermostat should be wired into the system. This is usually done at the programmer, in which case the programmer selector switches are set to OFF and all the other controls MUST be left in the running position.

The frost thermostat should be sited in a cold place but where it can sense heat from the system.

If the boiler is installed in a garage it may be necessary to fit a pipe thermostat, preferably on the return pipework.

Designation of the terminals will vary but the programmer and thermostat manufacturers' leaflets will give full details.

IMPORTANT.

Ensure that the frost thermostat is wired so that the system pump and / or external flow control valve is energised as appropriate.

Diagram A shows an application to boilers fitted with a room thermostat only.

Diagrams B & C show applications to boilers fitted with alternative time controls.

Earths are not shown for clarity but must never be omitted.

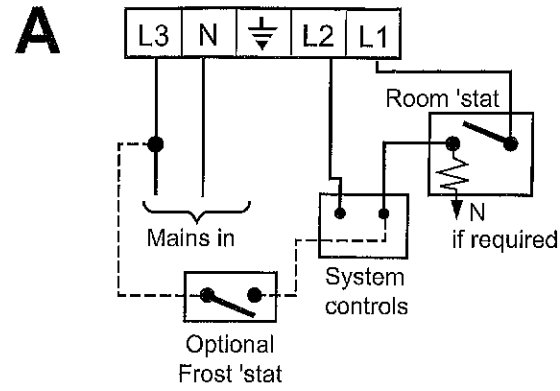

Ecl 6069

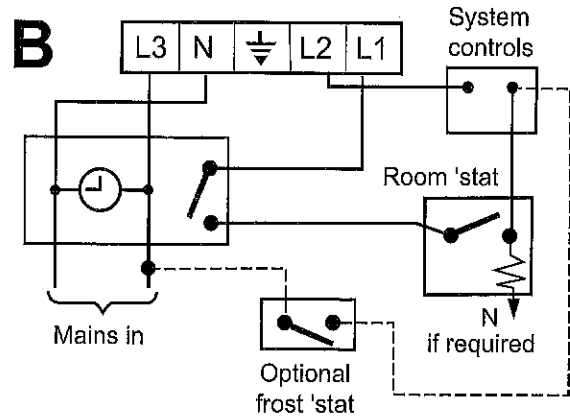

Ecl 6070

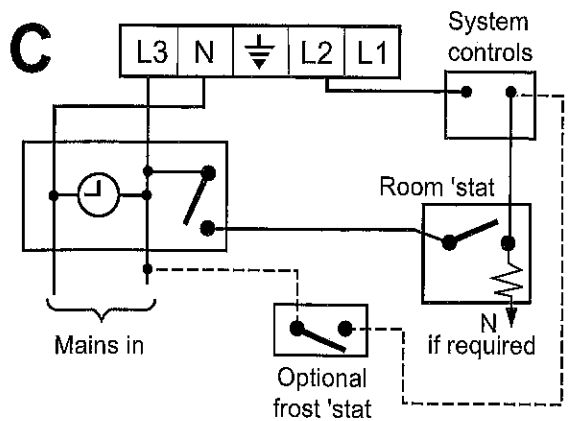

Ecl 6071

INSTALLATION

32 PICTORIAL WIRING DIAGRAM

LEGEND

b - blue	r - red
bk - black	v - violet
br - brown	w - white
gy - grey	y - yellow
or - orange	y/g - yellow/green
pk - pink	

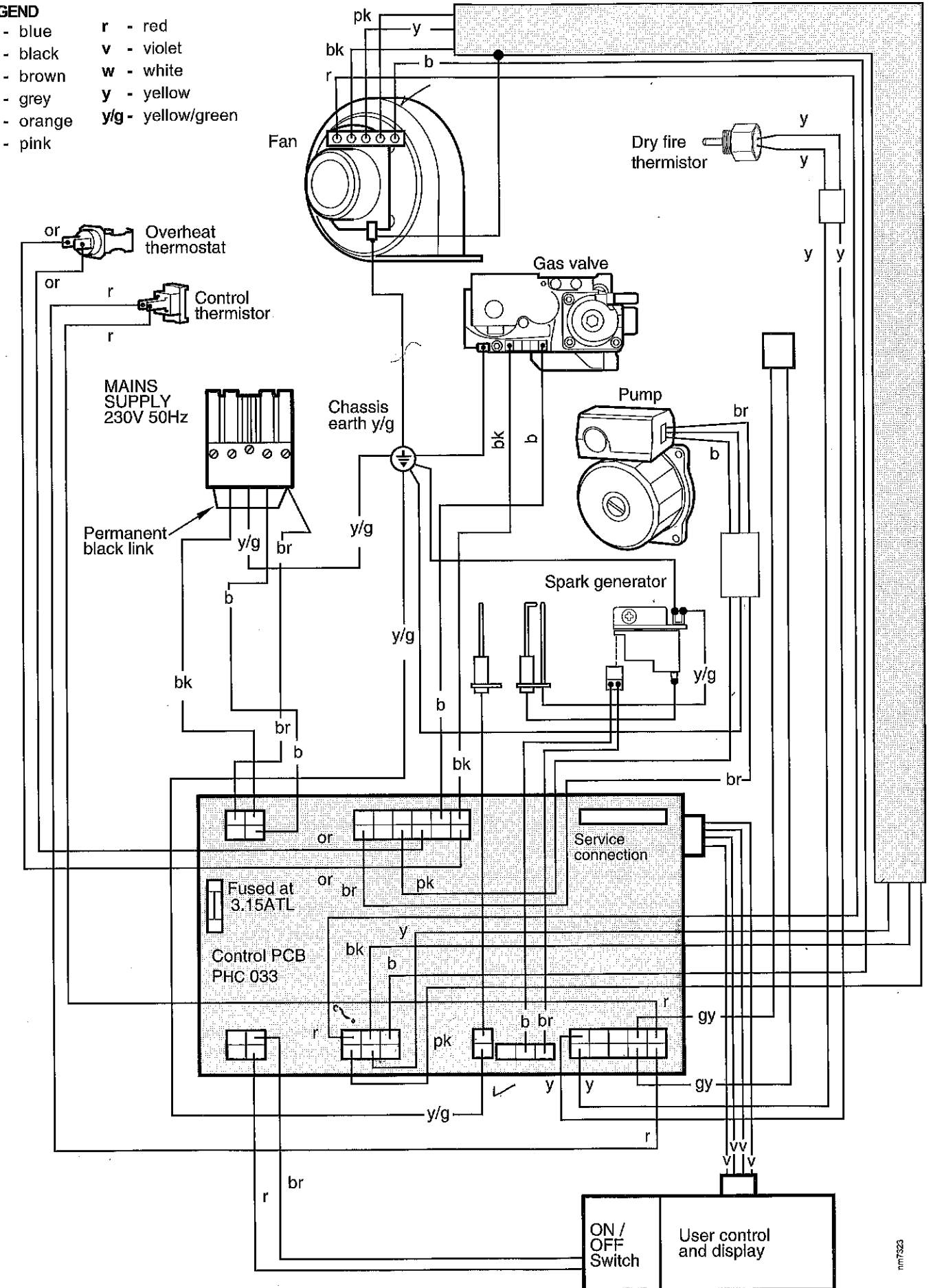

nm1323

INSTALLATION

33 FUNCTIONAL FLOW WIRING DIAGRAM

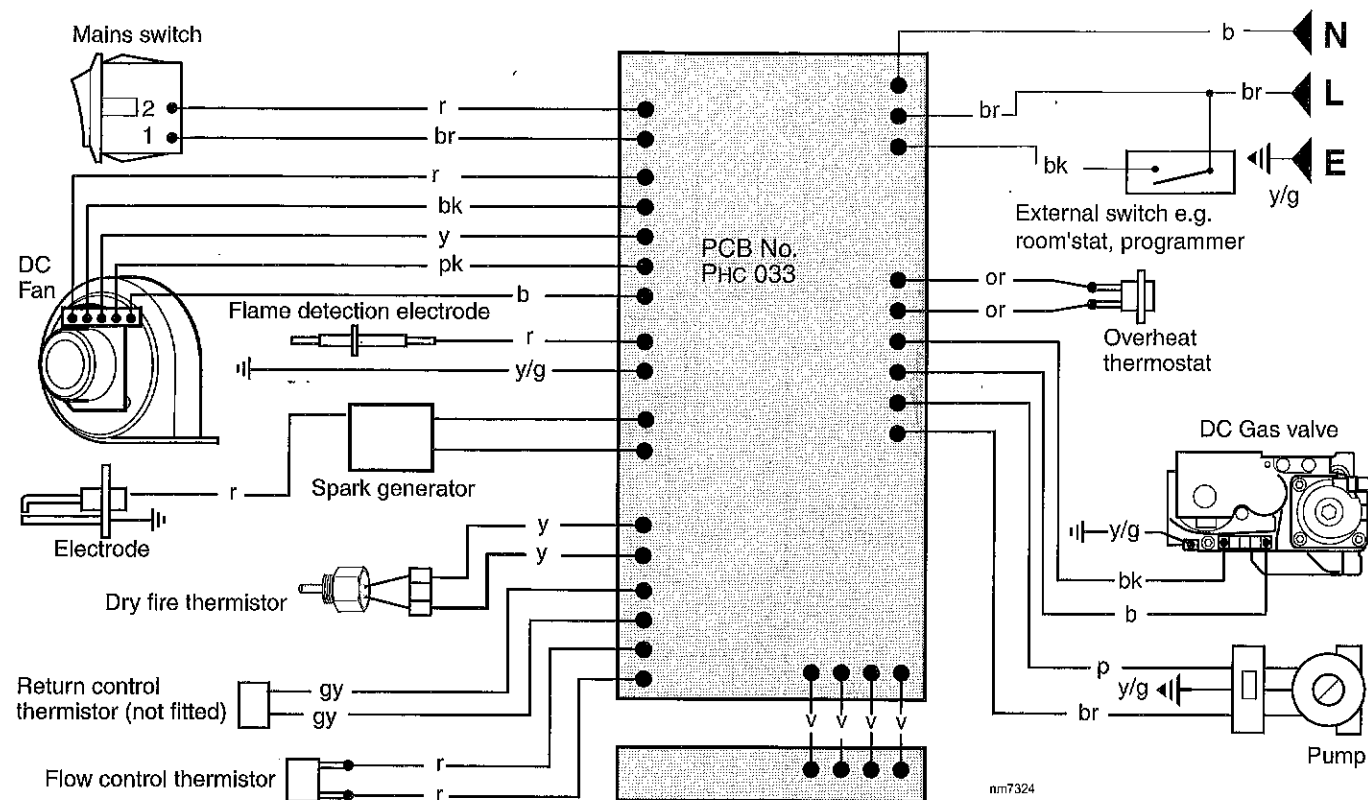

LEGEND

b - blue	r - red
bk - black	v - violet
br - brown	w - white
gy - grey	y - yellow
or - orange	y/g - yellow/green
pk - pink	

34 COMMISSIONING AND TESTING

A. Electrical Installation

1. Checks to ensure electrical safety should be carried out by a competent person.
2. ALWAYS carry out the preliminary electrical system checks, i.e. earth continuity, polarity, resistance to earth and short circuit, using a suitable test meter.

B. Gas Installation

1. The whole of the gas installation, including the meter, should be inspected and tested for soundness and purged in accordance with the recommendations of BS. 6891. In IE refer to I.S.813:2002.
2. Purge air from the gas installation by the approved methods only.

WARNING. Whilst effecting the required gas soundness test and purging air from the gas installation, open all windows and doors, extinguish naked lights and **DO NOT SMOKE.**

INSTALLATION

35 INITIAL LIGHTING

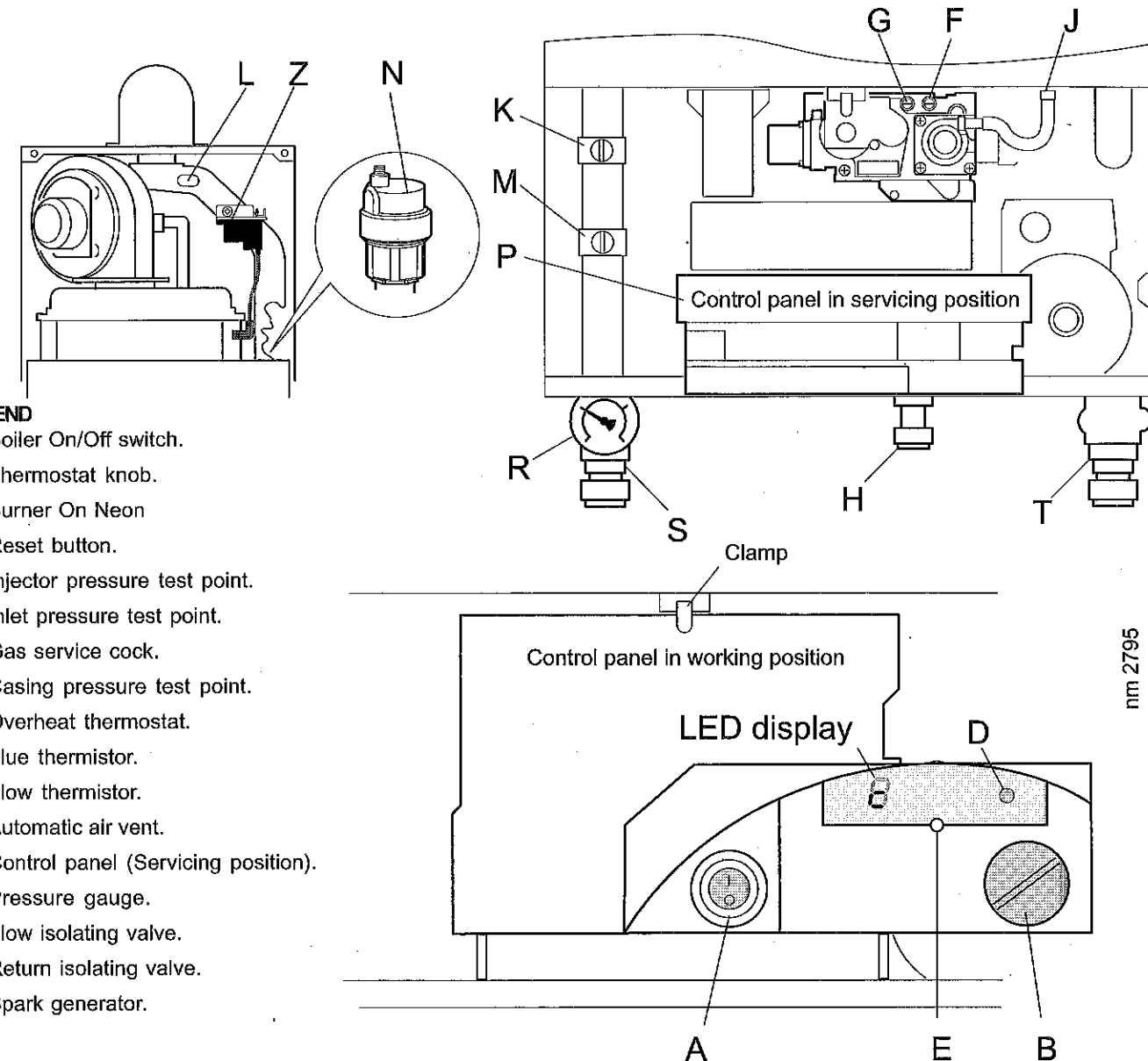

LEGEND

- A. Boiler On/Off switch.
- B. Thermostat knob.
- D. Burner On Neon
- E. Reset button.
- F. Injector pressure test point.
- G. Inlet pressure test point.
- H. Gas service cock.
- J. Casing pressure test point.
- K. Overheat thermostat.
- L. Flue thermistor.
- M. Flow thermistor.
- N. Automatic air vent.
- P. Control panel (Servicing position).
- R. Pressure gauge.
- S. Flow isolating valve.
- T. Return isolating valve.
- Z. Spark generator.

1. Check that the system has been filled and that the boiler is not airlocked. Ensure the automatic air vent cap (N) is open.

Note.

It is important the burner is not operated before the system is fully vented of air. If it is necessary to operate the appliance pump to assist venting of the air this must be done with the gas service cock turned off.

2. Refit the boiler sealing panel. Refer to Frame 41.
3. Check that all the drain cocks are closed and that the isolating valves (T and S) are OPEN.
4. Check that the electrical supply is OFF.
5. Check that the boiler on/off switch (A) is off.
6. Check that the gas service cock (H) is OPEN.
7. Carefully align the user control and push gently into place. Secure with the single screw located underneath.
8. Slacken the screw in the inlet pressure test point (G) and connect a gas pressure gauge via a flexible tube.
9. Swing the control panel to the working position and secure with the clamp.

10. Connect the low voltage electrical lead from the user control to the control box (refer to Frame 42).
11. Screw the control into position.
12. Switch the electricity supply ON and check all external controls are calling for heat.

The display

The user control has one neon and one display to inform the user about the status. The display will show the status of the boiler. The neon will show the status of the flame. If no flame is detected the neon is blinking. When the flame is detected the neon will be lit permanently.

Below is a list with the display function in normal operation.

- Standby, no demand for heat present.
- ☐ Boiler is active for central heating.
- H Boiler is in lockout for a specific error. Display will be blinking, alternating with a number or letter to show which error is detected.
- L Boiler in lockout for a specific error. Display will be blinking, alternating with a number or letter to show which is detected.

36 INITIAL LIGHTING - continued

13. Set the boiler thermostat knob (B) to position 6 and switch the boiler on/off switch (A) to ON. The boiler control should now go through its ignition sequence until the burner is established.
14. If the boiler does not light after 3 attempts, fault code **L F** will be displayed. Press the reset button (E) and the boiler will repeat its ignition sequence.

When the burner is established the WHITE 'Burner On' neon (D) will be illuminated and the LED display will show status **c**.
15. Ensure that with the boiler operating the dynamic gas pressure is able to obtain maximum output. Refer to Table 2.

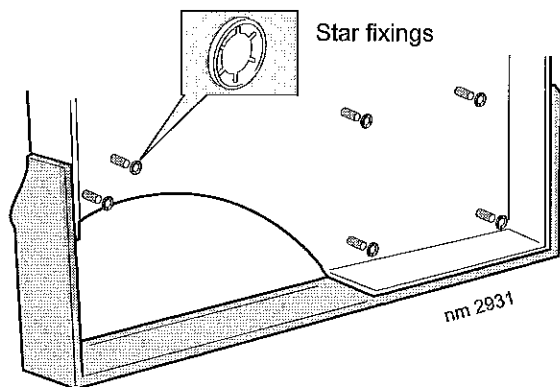

- N.B.** The principle of the 1:1 gas valve ensures that the **icos system HE24** is able to deliver its full output at inlet pressures well below those required by BS.6891.
- IMPORTANT.**
The gas input to the burner is regulated by the gas valve according to the air flow produced by the fan. It is **NOT user-adjustable**. Any interference to sealed settings on the gas valve will adversely affect operation and render our warranty void.
16. Set the boiler on/off switch (A) to OFF.
 17. Swing the control box into the servicing position. Refer to Frame 42.
 18. Remove the pressure gauge and tube. Tighten the sealing screw in the pressure test point. Ensure a gas tight seal is made.
 19. Swing the control box back into its working position and secure.
 20. Refit the user control.
 21. Refit the boiler front and bottom panels.
 22. **THE FASCIA**
 - a. To remove the plastic fascia, prise off the retaining star washers using a pair of pliers and place to one side.
 - b. Fill the remaining fixing holes with the white push in caps provided.
 23. Switch the boiler on again.

37 GENERAL CHECKS

Make the following checks for correct operation:

1. Ensure that the external controls are calling for heat. After ignition the display should read:
c * white neon on.
 2. **Gas Rate**
Check the boiler gas rate when the boiler is at full output checked at the gas meter, with no other appliance in use.
Refer to Table 2 for gas rates.
 3. Set the external controls to OFF. The burner should go off and the pump continue to run for a few seconds.
The display should read:
c returning to
□ when the pump stops.
 4. Check the correct operation of the programmer (if fitted) and all other system controls. Operate each control separately and check that the main burner responds.
- Water circulation system**
5. With the system COLD, check that the initial pressure is correct to the system design requirements. For pre-pressurised systems, this should be 1.0 bar.
 6. With the system HOT, examine all water connections for soundness. The system pressure will increase with temperature rise but should not exceed 2.5 bar.
 7. With the system still hot, turn off the gas, water and electricity supplies to the boiler and drain down to complete the flushing process.

Note. A flushing solution should be used during the flushing procedure: Flushing solutions Fernox Superfloc, Sentinel X300 (new systems) or X400 (existing systems). Refer to Frame 6.

8. Refill and vent the system, add inhibitor (see Frame 6), clear all air locks and again check for water soundness.
Affix the water treatment warning label, supplied in the hardware pack, in a prominent position on the system, to prevent the use of incorrect water treatment additives.
9. Reset the system initial pressure to the design requirement.
10. Balance the system. Refer to Frame 5.
11. Check the condensate drain for leaks and check that it is discharging correctly.
12. Finally, set the controls to the User's requirements.

Note.
The pump will operate briefly as a self-check once every 24 hours in the absence of any system demand.

WATER TEMPERATURE

Water temperature can be selected via the thermostat (B)

Knob Setting	Flow Temp °C (°F)
Max	82 (180)
Min	30 (86)

38 HANDING OVER

After completing the installation and commissioning of the system the installer should hand over to the householder by the following actions:

1. Hand the User Instructions to the householder and explain his/her responsibilities under the relevant national regulations.
2. Explain and demonstrate the lighting and shutting down procedures.
3. The operation of the boiler and the use and adjustment of all system controls should be fully explained to the householder, to ensure the greatest possible fuel economy consistent with the household requirements of heating.

Advise the User of the precautions necessary to prevent damage to the system and to the building in the event of the system remaining inoperative during frosty conditions.
4. Explain the function and the use of the boiler heating controls.
5. Explain the function of the boiler fault mode.

Emphasise that if a fault is indicated, the boiler should be turned off and a CORGI registered installer consulted. In IE contact a Competent Person.
6. Explain and demonstrate the function of time and temperature controls, radiator valves etc., for the economic use of the system.

7. If any programmer is fitted then draw attention to the Programmer Users Instructions and hand them to the householder.
8. **Loss of system water pressure**

Explain that the dial underneath the boiler indicates the central heating system pressure and that if the normal COLD pressure of the system is seen to decrease over a period of time then a water leak is indicated. In this event a CORGI registered installer should be consulted. In IE consult a Competent Person.
- WARNING.**
Do not fire the boiler if the pressure has reduced to zero from the original setting.
9. **After installation, commissioning and customer hand-over please complete the *benchmark* appliance log book and leave this with the customer. For IE, it is necessary to complete a "Declaration of Conformity" to indicate compliance to I.S.813:2002.**
10. **IMPORTANT**
Stress the importance of regular servicing by a CORGI registered installer and that a comprehensive service should be carried out AT LEAST ONCE A YEAR. In IE servicing work must be carried out by a Competent Person.
11. As the installer you may wish to undertake the service contract yourself or alternatively offer to the customer the benefits of the Ideal Care Scheme, details of which are outlined in the householder pack supplied with this boiler.

39 SERVICING SCHEDULE

To ensure the continued safe and efficient operation of the appliance it is recommended that it is checked at regular intervals and serviced as necessary. The frequency of servicing will depend upon the installation condition and usage but should be carried out at least annually.

It is the law that any service work must be carried out by a CORGI registered installer. In IE service work must be carried out by a competent person.

1. Light the boiler and carry out a pre-service check, noting any operational faults.
2. Check the gas consumption.
3. Connect a suitable gas analyser to the sampling point on the top of the boiler (refer to Frame 41) or into the flue terminal if access is possible (optional test). For correct boiler operation the CO/CO₂ content of the flue gas should not be greater than 0.004 ratio. If this is the case, and the gas input is at least 90% of the nominal, then no further action need be taken. If not, proceed to Step 4 but see note above.
4. Clean the main burner.
5. Clean the heat exchanger and 'S' trap.
6. Check the condition of the combustion chamber insulation. Any cracked/damaged pieces should be replaced.
7. Check the main injector for blockage or damage.

8. Wherever possible remove and clean the condensate 'S' trap (refer to Frame 45) and check the drain for blockage.
9. Check that the flue terminal is unobstructed and that the flue system is sealed correctly.

The servicing procedures are covered more fully in Frames 40 to 47 and MUST be carried out in sequence.

Note. In order to carry out either servicing or replacement of components the boiler front panel and sealing panel must be removed. Refer to Frames 40 and 41.

WARNING. Always turn OFF the gas supply at the gas service cock, and switch OFF and disconnect the electricity supply to the appliance before servicing.

IMPORTANT.

10. After completing the servicing or exchange of components always test for gas soundness and carry out functional checks as in 2 and 3 above.

11. When work is complete the sealing panel MUST be correctly refitted, ensuring that a good seal is made.

Do NOT OPERATE the boiler if the sealing panel is not fitted

12. If, for any reason, the condensate trap 'S' has been removed ensure that the trap is refilled with water before reassembly.
13. Complete the service section in the Benchmark log book.

40 BOILER FRONT PANEL REMOVAL

1. Remove the 2 retaining screws from the underside of the boiler.
2. Pull the panel forward at the bottom and lift to disengage it from the top lugs.

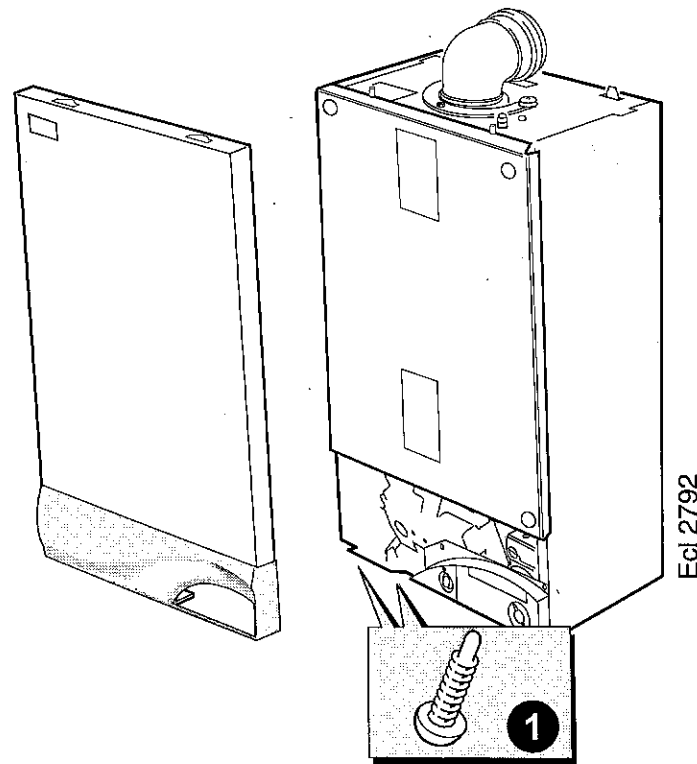

41 BOILER SEALING PANEL / BOTTOM PANEL REMOVAL

1. To remove the sealing panel remove the 4 screws.
2. Remove the panel.
3. To remove the bottom panel remove the 2 screws.
4. Pull the right hand side of the panel down. Slide it to the right and withdraw.

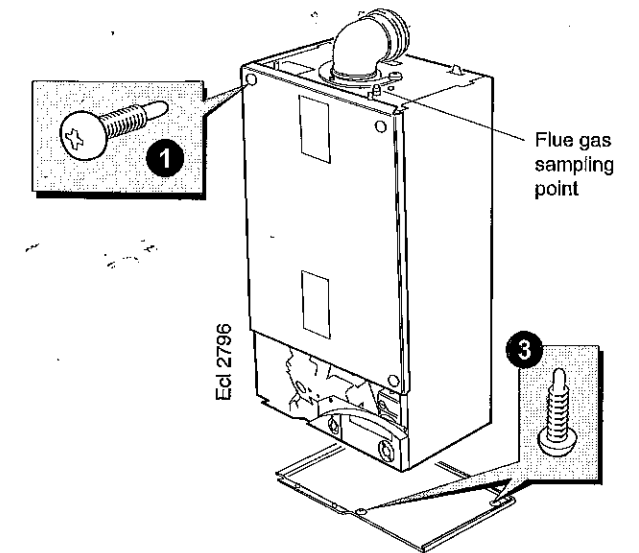

42 THE CONTROL BOX IN THE SERVICING POSITION

1. Remove the 2 screws and withdraw the user control.
2. Unplug the low voltage electrical lead from the back of the user control.
3. Turn the clamp, swing the control box down and pull slightly forward.

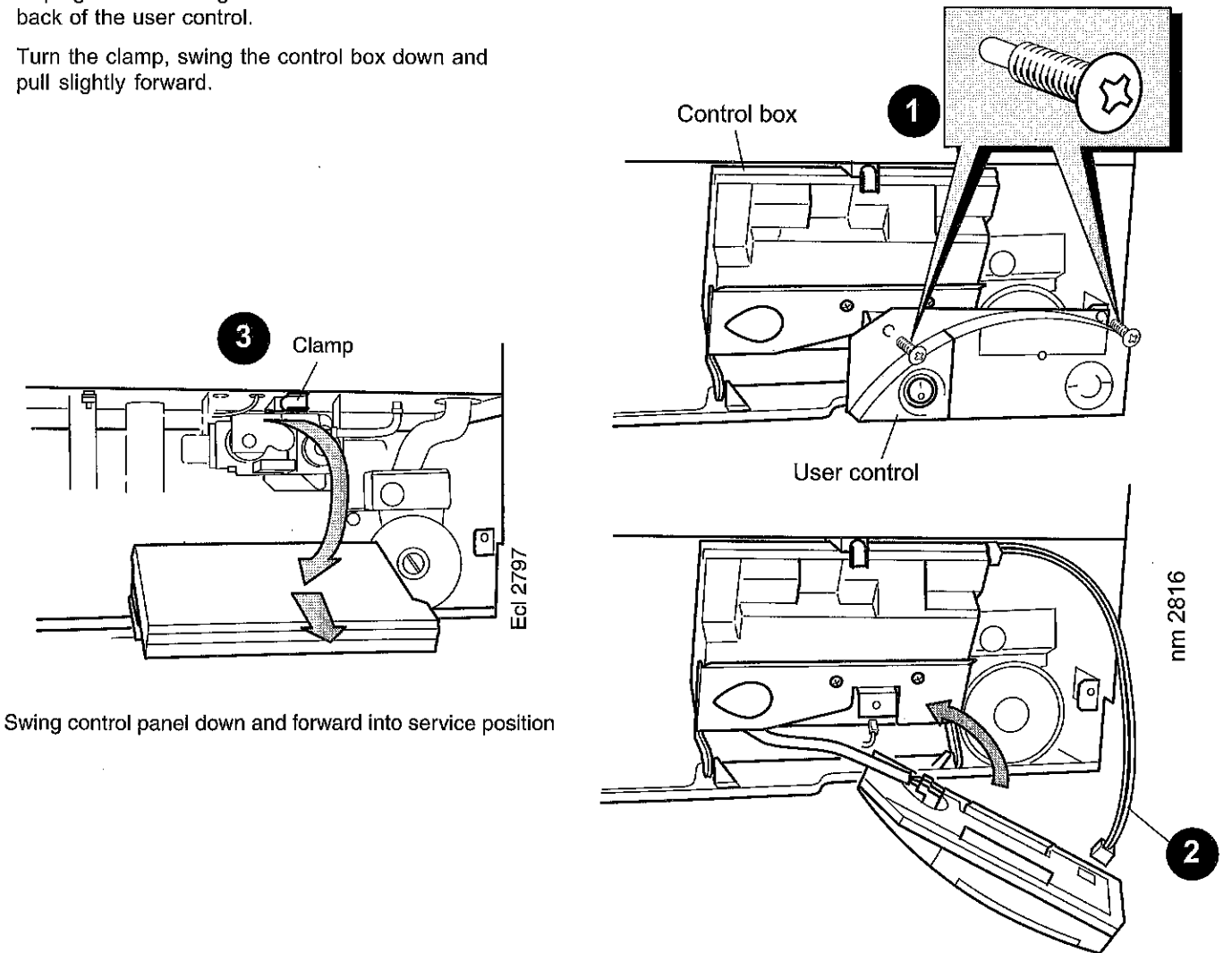

SERVICING

43 FAN AND VENTURI ASSEMBLY REMOVAL AND CLEANING

1. Disconnect the electrical leads from the fan.
2. Undo the gas pipe union connection to the injector housing.
3. Undo the screw on the fan mounting bracket.
4. Lift off fan and venturi assembly.
5. Inspect the injector for blockage or damage.

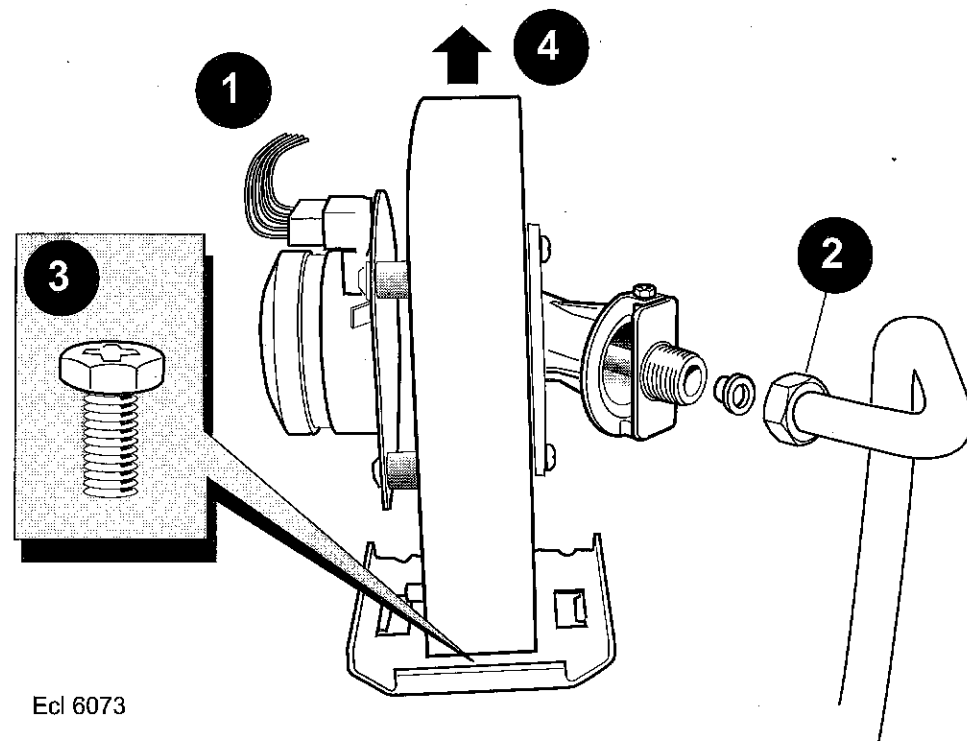

44 BURNER REMOVAL AND CLEANING

1. Remove the 6 screws retaining the burner (the 3 screws at the rear are extended to ease access).
2. Lift off the burner from the combustion chamber.

IMPORTANT

The burner head is a ceramic plaque construction. Care must be taken to ensure that the burner is not placed down upon its face as this may cause damage to the ceramic.

3. Brush off any deposits that may be on the ceramic with a SOFT brush.
4. Inspect the sealing gasket around the burner and combustion chamber insulation for any signs of damage. Replace as necessary.

Note.

Take care not to disturb the detection earth probe at the rear of the combustion chamber.

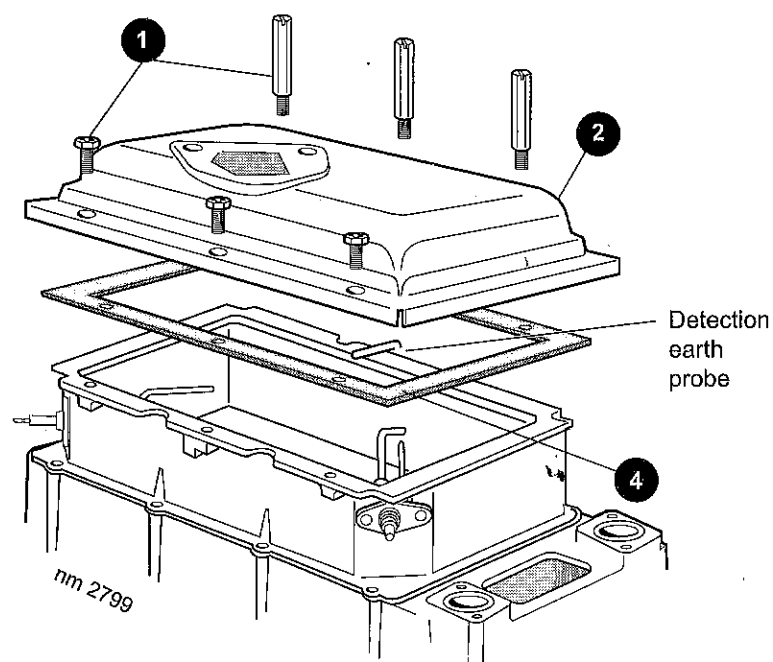

SERVICING

45 CLEANING THE CONDENSATE 'S' TRAP

1. Swing the control box down into the servicing position. Refer to Frame 42.
2. Disconnect the condensate drain pipe.
3. Remove the screw and elongated bolt, pull the trap down and forward to remove.
4. Flush out any deposits with clean water.

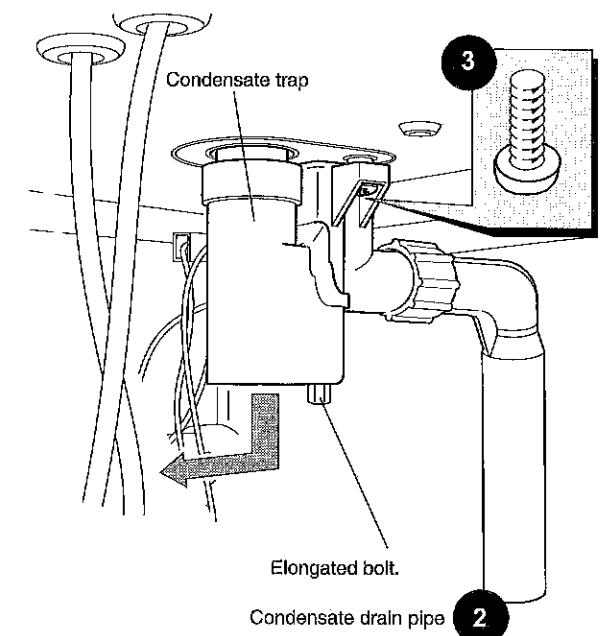

46 CLEANING THE HEAT EXCHANGER

1. Remove ignition and flame detection electrodes. Refer to Frames 54 & 55.
2. Remove the 3 screws retaining the sump cover and remove.
3. Using a suitable tool as supplied in the standard British Gas Flue brush kit, clean between the heat exchanger fins from the top of the heat exchanger.
4. Access to the base of the heat exchanger is now possible. Brush clean any deposits from the base of the heat exchanger and remove any loose deposits from the sump.
5. Inspect the ignition and detection electrodes. Ensure that they are clean and in good condition - replace if necessary.
6. Check the condition of the combustion chamber insulation. Any cracked/damaged pieces should be replaced.
7. Check that the ignition and detection gaps are correct. Refer to Frames 54 & 55.

Note.

Take care not to disturb the detection earth probe at the rear of the combustion chamber.

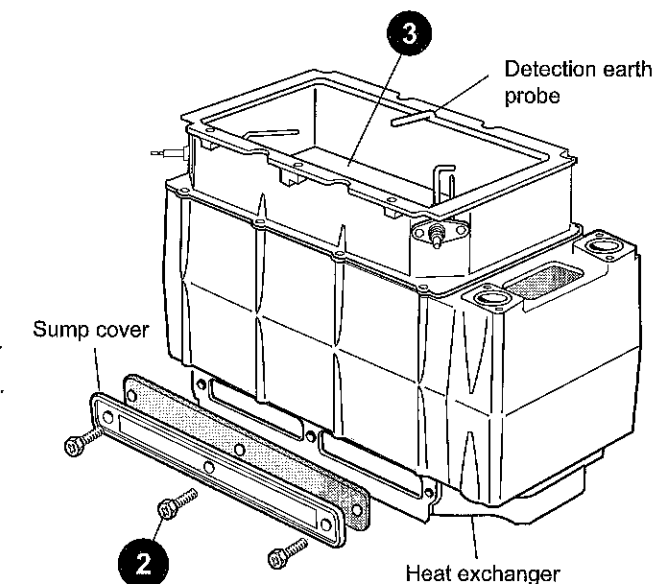

47 REASSEMBLY

Reassemble the boiler in the following order:

1. Refit the condensate 'S' trap, ensuring that it is full of water.
2. Refit the sump cover.
3. Refit the electrodes. (Check dimensions; Frames 54 & 55).
4. Refit the burner.
5. Refit the fan / venturi assembly.
6. Reconnect the fan electrical leads.
7. Refit the boiler sealing panel.

IMPORTANT.

Ensure that the boiler sealing panel is correctly fitted and that a good seal is made.

8. Swing the control box back into its working position and secure.
9. Refit the display unit.
10. Refit the boiler front and bottom panels.
11. Turn on the gas supply at the gas service cock.
12. Reconnect the electrical supply.

48 REPLACEMENT OF COMPONENTS

GENERAL

When replacing ANY component :

1. Isolate the electricity supply.
2. Turn off the gas supply.
3. Remove the boiler front panel. Refer to Frame 40.

After replacing ANY component check operation of the boiler including gas soundness, gas rate and combustion test.

IMPORTANT.

When work is complete, the sealing panel, if removed, must be correctly refitted - ensuring that a good seal is made.

Notes.

1. In order to assist fault finding, the control panel has an LED diagnostic display. The key to boiler fault conditions is shown in Frame 71 .
2. In order to replace components in Frames 63-69 it is necessary to drain the boiler. Refer to Frame 66.

THE BOILER MUST NOT BE OPERATED WITHOUT THE SEALING PANEL FITTED

49 DRY FIRE THERMISTOR REPLACEMENT

1. Refer to Frame 48.
2. Remove the boiler front and sealing panels. Refer to Frames 40 & 41.
3. Drain down the boiler. Refer to Frame 66.
4. Unplug the electrical lead.
5. Unscrew the thermistor.
6. Fit the new thermistor using the sealing washer provided.
7. Reassemble in the reverse order.
8. Check the operation of the boiler.

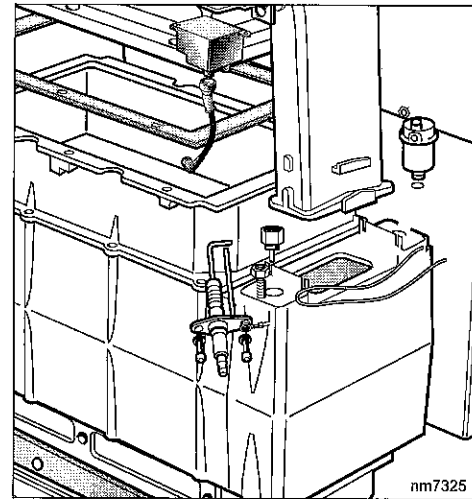

50 FAN REPLACEMENT

1. Refer to Frame 48.
2. Remove the boiler front and sealing panels. Refer to Frames 40 & 41.
3. Disconnect the electrical leads from the fan.
4. Undo the gas pipe union connection to the injector housing.
5. Remove the screw retaining the fan mounting bracket.
6. Remove the fan and venturi assembly. Refer to Frame 43.
7. Unscrew the 3 screws and remove the venturi assembly, noting the orientation of the venturi in relation to the fan body.
8. Transfer the venturi assembly to the new fan, replacing the gasket if evidence of damage or deterioration is visible.
9. Fit the new fan / venturi assembly.
10. Reassemble the boiler in reverse order, taking care not to overtighten the screw on the fan mounting bracket.
11. Check the operation of the boiler. Refer to Frame 48.

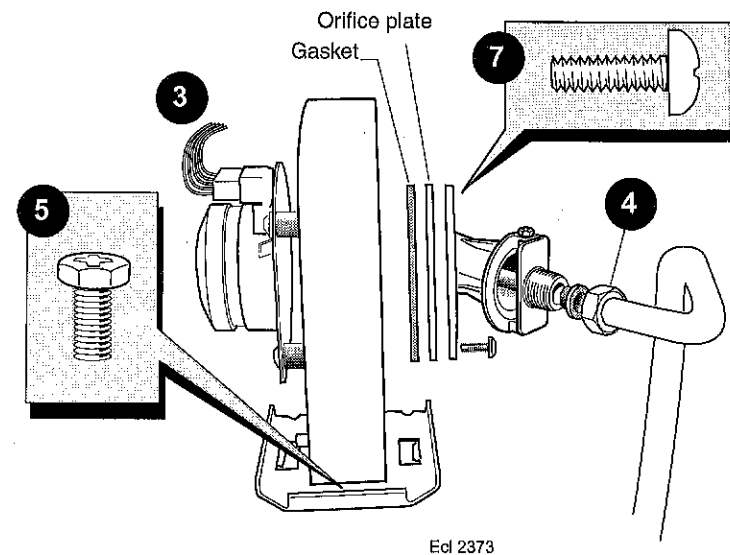

Ecl 2373

51 BURNER INJECTOR REPLACEMENT

1. Refer to Frame 48.
2. Remove the boiler front and sealing panels. Refer to Frames 40 & 41.
3. Disconnect the electrical leads from the fan.
4. Undo the gas pipe union connection to the injector housing.
5. Remove the screw retaining the fan mounting bracket.
6. Remove the fan and venturi assembly. Refer to Frame 43.
7. Remove the 2 injector housing screws.
8. Withdraw the injector housing.
9. Fit the new injector housing, complete with injector.
10. Reassemble in reverse order, ensuring that the new gas seal supplied is located correctly in the injector housing.
11. Check operation of the boiler. Refer to Frame 48.

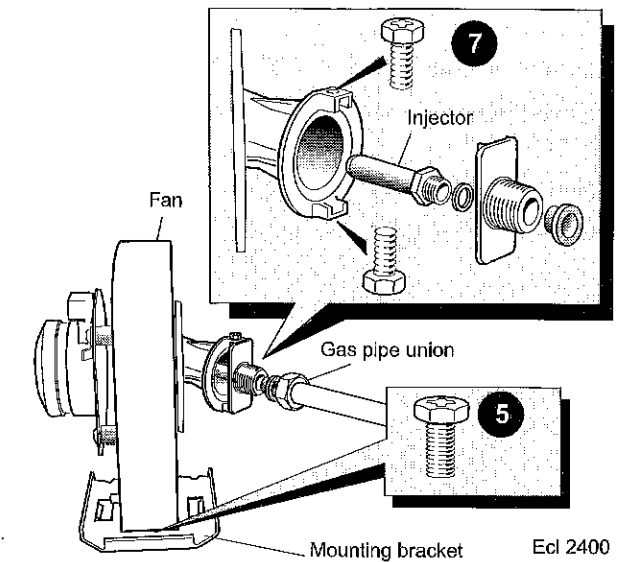

Ecl 2400

52 BURNER REPLACEMENT

1. Refer to Frame 48.
2. Remove the boiler front and sealing panels. Refer to Frames 40 & 41.
3. Remove the fan assembly. Refer to Frame 43.
4. Remove the 6 screws securing the burner (the 3 screws at the rear are extended to ease access).
5. Lift off the burner from the combustion chamber.
6. Fit the new burner, replacing any damaged or deteriorating sealing gasket.
7. Reassemble in reverse order.
8. Check the operation of the boiler. Refer to Frame 48.

Note.

Take care not to disturb the detection earth probe at the rear of the combustion chamber.

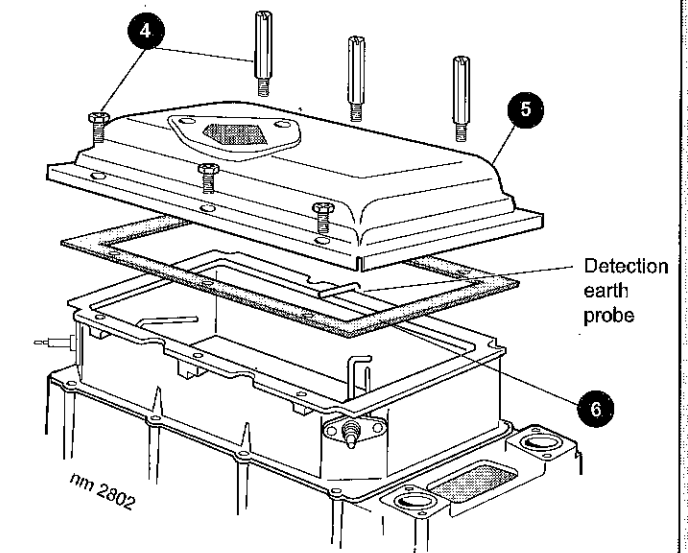

nm 2802

53 CONTROL THERMISTOR AND OVERHEAT THERMOSTAT REPLACEMENT

1. Refer to Frame 48.
2. Remove the boiler front and sealing panels. Refer to Frames 40 & 41.
3. Unclip the thermistor / thermostat from the flow pipe and withdraw it from the controls compartment.
4. Disconnect the electrical leads from the thermistor/ thermostat.
5. Reconnect the electrical leads and reassemble in reverse order, ensuring the spring clip is securely on the pipe.
6. Check the operation of the boiler. Refer to Frame 48.

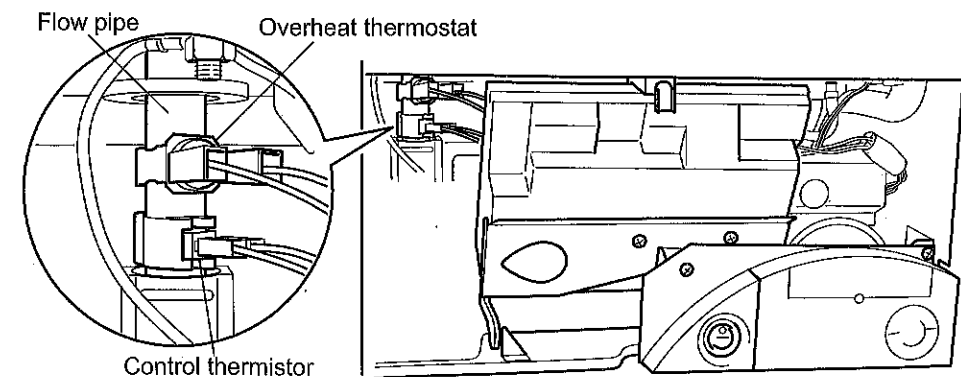

Ecl 6084

54 IGNITION ELECTRODE REPLACEMENT

1. Refer to Frame 48.
2. Remove the boiler front and sealing panels. Refer to Frames 40 & 41.
3. Unplug the ignition lead from the electrode.
4. Remove earth lead from the ignition electrode.
5. Remove the remaining screw holding the ignition electrode to the combustion chamber.
6. Remove the electrode.
7. Fit the new ignition electrode, using the new gasket supplied. Check dimensions as shown.
8. Reassemble in reverse order and check that no damage to the combustion chamber insulation has occurred during the electrode replacement.
9. Check the operation of the boiler. Refer to Frame 48.

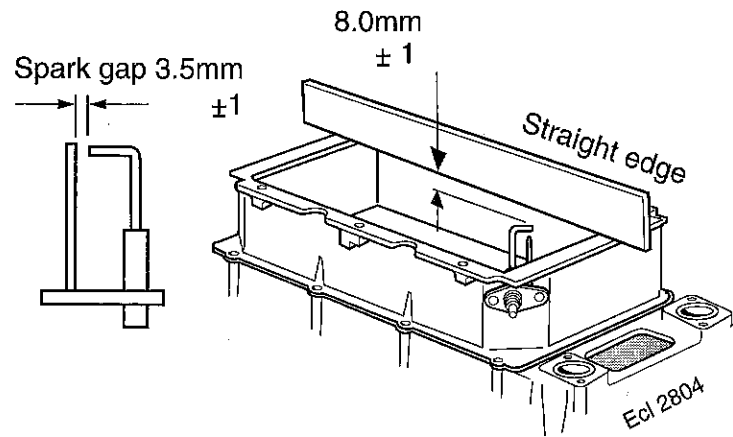
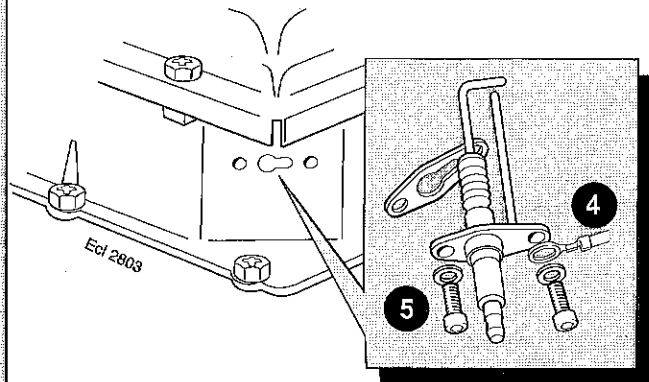

55 FLAME DETECTION ELECTRODE REPLACEMENT

1. Refer to Frame 48.
2. Remove the boiler front and sealing panels. Refer to Frames 40 & 41.
3. Unplug the flame detection lead from the electrode.
4. Remove the 2 screws holding the flame detection electrode to the combustion chamber.
5. Remove the electrode.
6. Fit the new flame detection electrode, using the new gasket supplied. Check dimensions as shown.
7. Reassemble in reverse order and check that no damage to the combustion chamber insulation has occurred during the electrode replacement.
8. Check the operation of the boiler. Refer to Frame 48.

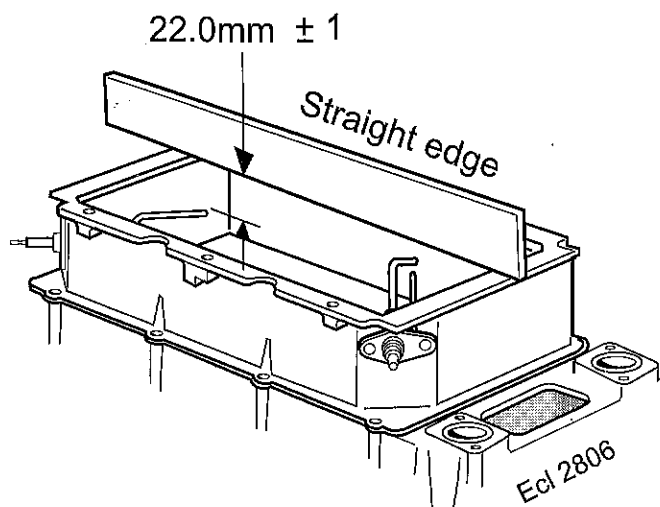
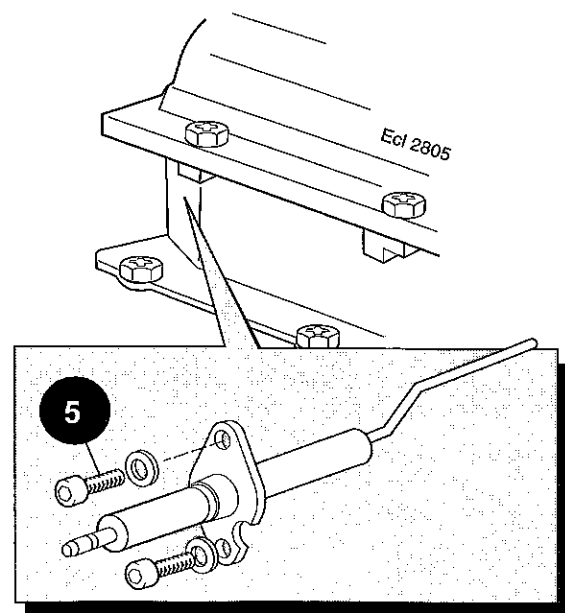

56 SPARK GENERATOR REPLACEMENT

1. Refer to Frame 48.
2. Disconnect the leads from the spark generator and bracket.
3. Remove the M5 screw securing the spark generator bracket to the flue casting.
4. Remove the 2 M4 screws securing the spark generator to the bracket.
5. Fit the new spark generator and re-assemble in reverse order.
6. Check operation of the boiler. Refer to Frame 48.

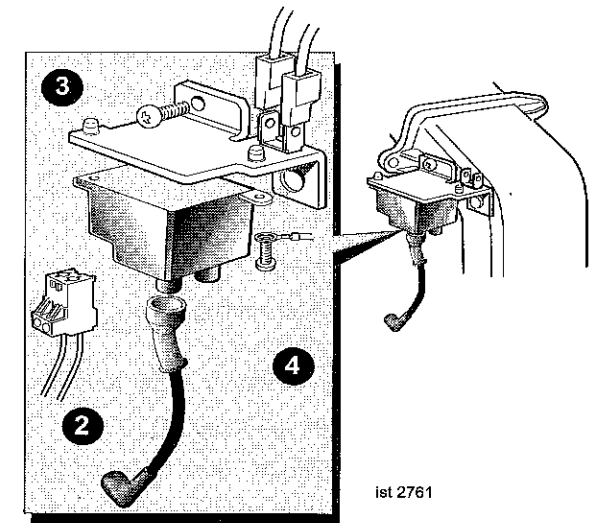

57 GAS CONTROL VALVE REPLACEMENT

1. Refer to Frame 48.
2. Remove the boiler front and bottom panels. Refer to Frames 40 & 41.
3. Swing the control box down into the servicing position. Refer to Frame 42.
4. Unplug the electrical lead from the gas control valve and disconnect the earth wire.
5. Remove the sensing tube from the gas control valve.
6. Undo the gas inlet pipe union at the gas service cock.
7. Undo the union nut on the outlet of the gas control valve.
8. Slacken the screw securing the valve mounting bracket and withdraw the valve, complete with bracket and inlet pipe.
9. Transfer the mounting bracket and gas inlet pipe to the new gas control valve.
10. Fit the new gas control valve, ensuring that any seals showing damage or deterioration are replaced. Reassemble in reverse order.
11. Ensure the sensing tube is correctly replaced and not kinked or blocked in any way.
12. Check operation of the boiler. Refer to Frame 48.

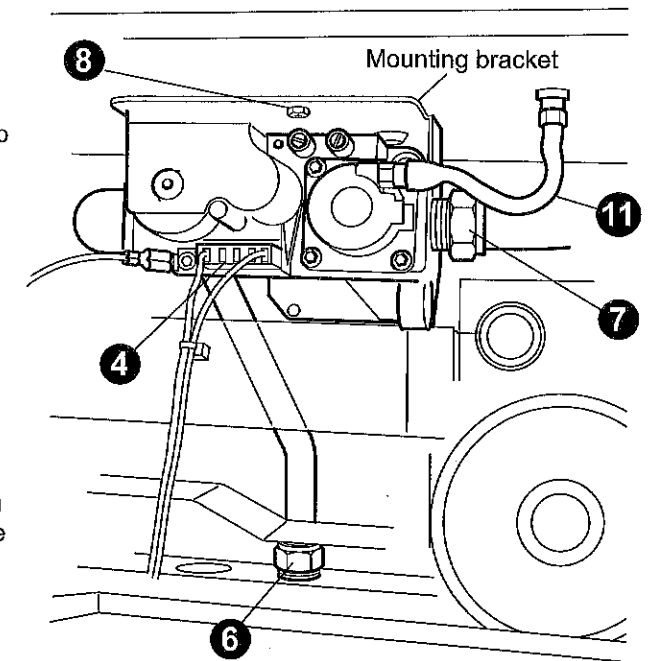

58 CONDENSATE 'S' TRAP REPLACEMENT

1. Refer to Frame 48.
2. Remove the boiler front and bottom panels. Refer to Frames 40 & 41.
3. Swing the control box down into the servicing position. Refer to Frame 42.
4. Disconnect the condensate drain pipe.
5. Remove the screw and elongated bolt, pull the trap down and forward to remove.
6. Transfer the drain pipe to the new trap and reassemble in reverse order.
7. When reassembling ensure the trap is full of water.
8. Check operation of the boiler. Refer to Frame 48.

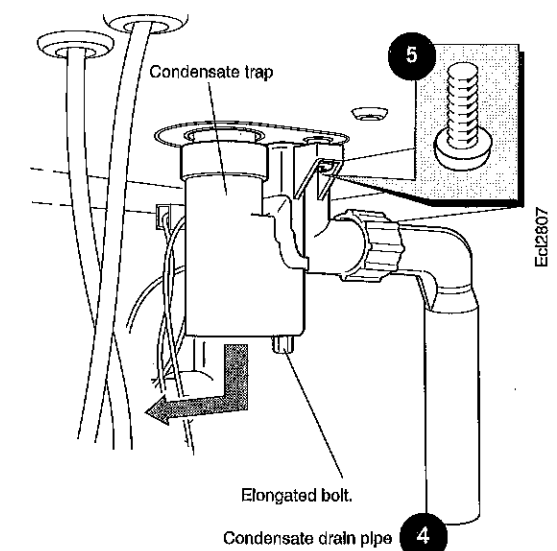

59 COMBUSTION CHAMBER INSULATION REPLACEMENT

The insulation boards used in the combustion chamber of this product are made of high temperature glass fibres with a binder of organic and inorganic materials.

Caradon Ideal Limited recommend that, for your own comfort and safety and to comply with good working practice, the procedure described below is followed:

1. Refer to Frame 48.
2. Remove the boiler front and sealing panels. Refer to Frame 40 & 41.
3. Remove the fan / venturi assembly. Refer to Frame 43.
4. Remove the burner. Refer to Frame 44.
5. Remove the ignition electrode. Refer to Frame 54.
6. Remove the flame detection electrode. Refer to Frame 55.

Prior to removal of the board the following protective equipment should be worn:

- Face mask supplied with the spare part
 - Gloves supplied with the spare part
7. Remove the detection earth probe.

Fit insulation in the following order:

1. Rear.
2. Left Hand Side.
3. Front.
4. Right Hand Side.

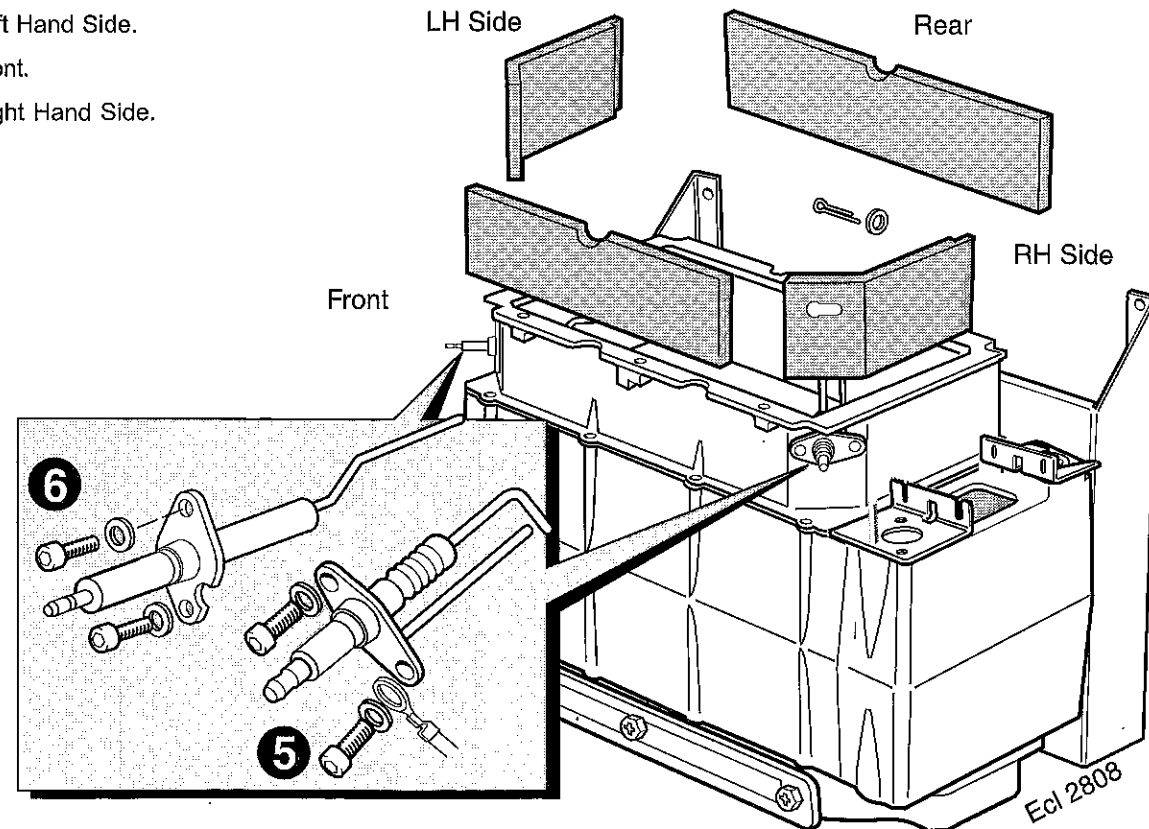

8. Damp down the combustion chamber area containing the insulation boards.
 9. Remove the split pin and washer from the RHS of the combustion chamber.
 10. Remove the insulation boards. The replacement boards are supplied in a plastic bag. This bag should be retained and the discarded boards should now be placed into it.
 11. Sweep any dampened particles and place in the plastic bag.
 12. Fit new insulation boards.
- Note.** The boards are designed to be interlocking and should be fitted as shown.
13. Fit the new split pin and washer in the RHS of the chamber.
 14. Remove the gloves and face mask and place them in the plastic bag.
 15. Wash your hands and any areas of skin which may have come into contact with any of the particles from the insulation board.
- Note.** Seal the plastic bag and dispose of it and its contents into a commercial tip.
16. Reassemble in reverse order.
 17. Check operation of the boiler. Refer to Frame 48.

60 CONTROL BOX REPLACEMENT

1. Refer to Frame 48.
2. Remove the boiler front and bottom panels. Refer to Frames 40 & 41.
3. Swing the control panel down into the servicing position. Refer to Frame 42.
4. Unplug the user control electrical lead and low voltage lead from the control box and remove the control. Refer to diagram A.
5. Return the control box to the working position and secure with the clamp. Unscrew the mounting bracket screws to remove the bracket. Refer to diagram B.
6. Release the clamp and carefully remove the control box from the hinge arms. Refer to diagram C.
7. Unplug all the electrical wiring from the control box and remove.
8. Transfer mounting bracket and hinge screws to the new control box.

9. Reassemble in reverse order, ensuring that the control box is located correctly in the housing before reconnecting the electrical wiring.
10. Check operation of the boiler. Refer to Frame 48.

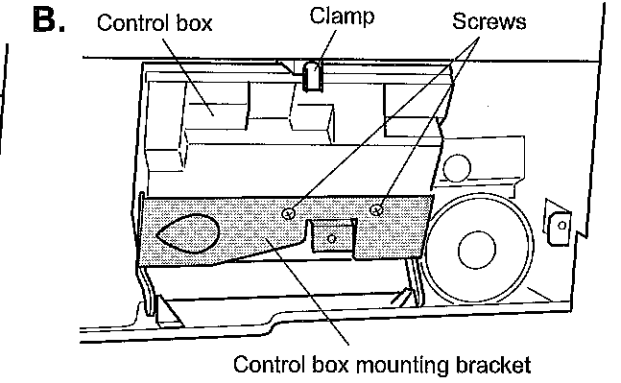
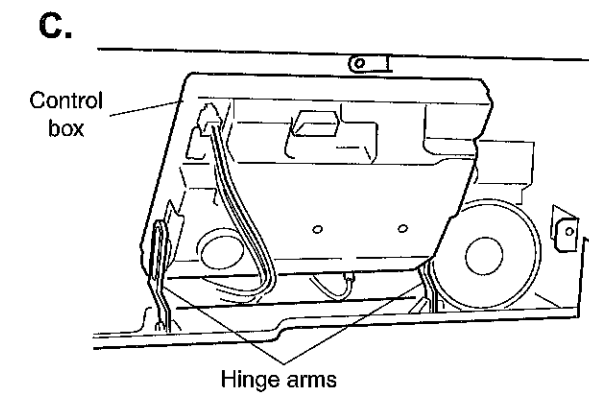
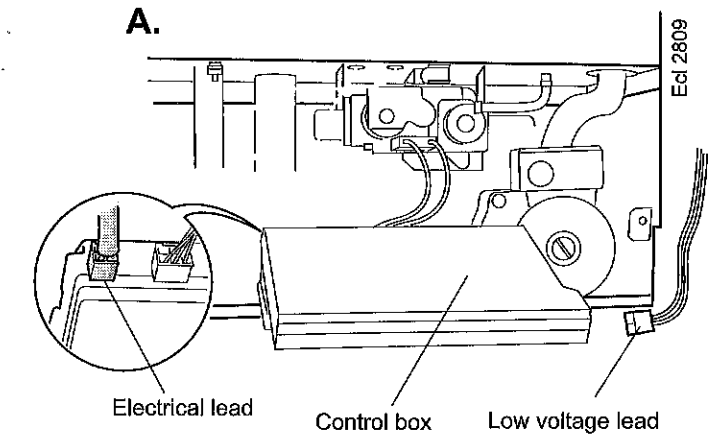

61 MAINS SWITCH REPLACEMENT

1. Refer to Frame 48.
2. Remove boiler front and bottom panels. Refer to Frames 40 & 41.
3. Remove the 2 screws and allow the user control to lower.
4. Push out the mains switch from the rear, as shown.

5. Fit the new switch, ensuring that the electrical leads are replaced on the correct terminals (refer to Frame 33) and the key on the switch is correctly aligned with the slot in the plastic moulding.
6. Reassemble in reverse order.
7. Check operation of the boiler. Refer to Frame 48.

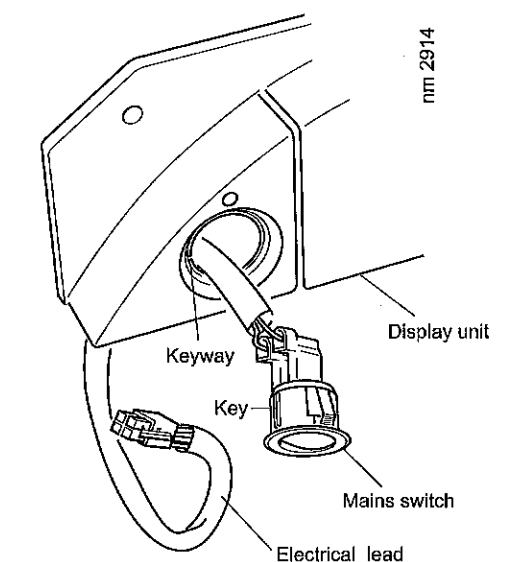
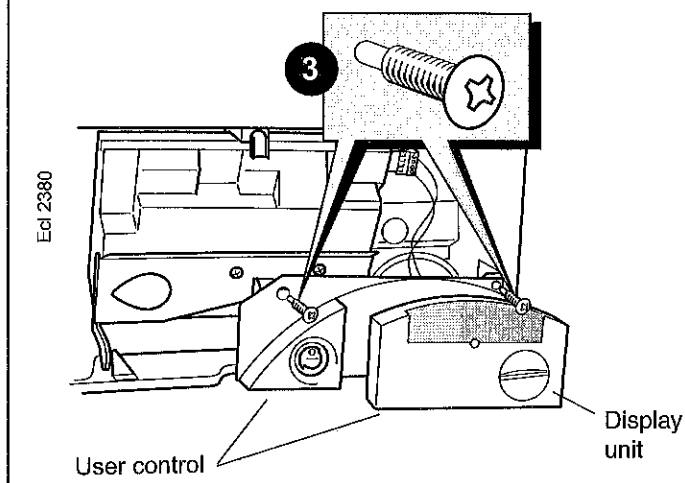

62 USER CONTROL REPLACEMENT

Note. Only the display unit is replaced.

1. Refer to Frame 48.
2. Loosen the screw on the underside of the user control.
3. Pull the display unit forward to remove.
4. Push the new display unit into position.
5. Reassemble in reverse order.
6. Check operation of the boiler. Refer to Frame 48.

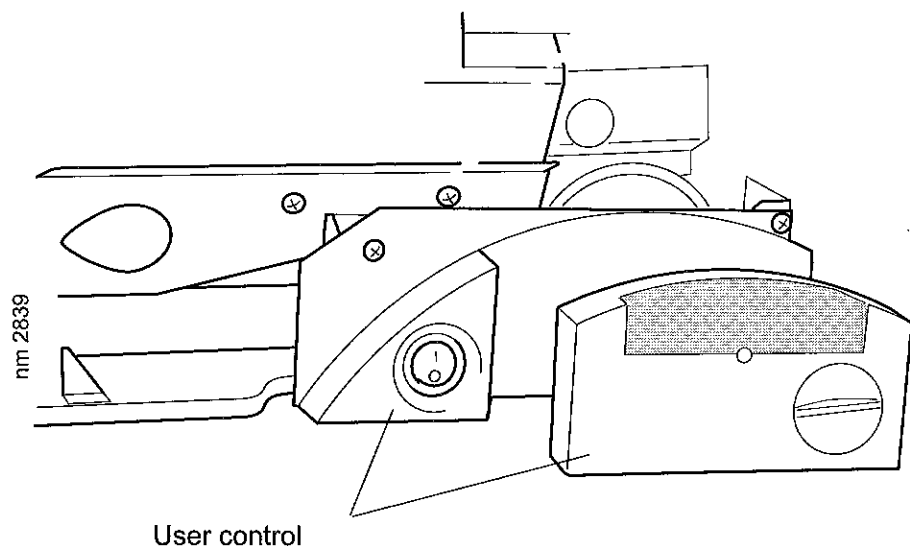
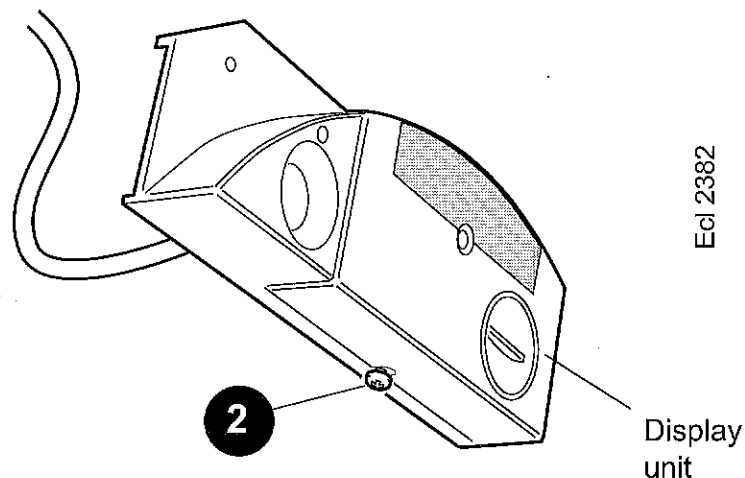

63 PRESSURE GAUGE REPLACEMENT

1. Refer to Frame 48.
2. Drain the boiler. Refer to Frame 66.
3. Unscrew the pressure gauge and discard.
4. Fit the new pressure gauge, using a suitable jointing compound.
5. Refill the boiler. Refer to Frame 28.
6. Check operation of the boiler. Refer to Frame 48.

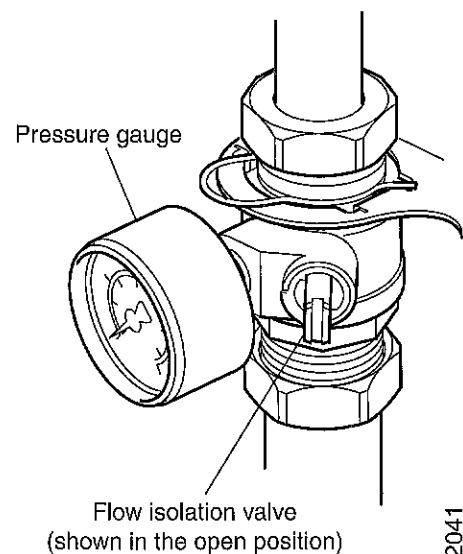

64 SAFETY RELIEF VALVE REPLACEMENT

1. Refer to Frame 48.
2. Remove the boiler front and bottom panels. Refer to Frame 40 & 41.
3. Drain the boiler. Refer to Frame 66.
4. Remove the discharge pipe.
5. Unscrew the 4 screws securing the rear support plate and withdraw the plate.

Note. The M4 screws fit the casing and the self-tapping screws fit the plastic pump and valve housing as shown.

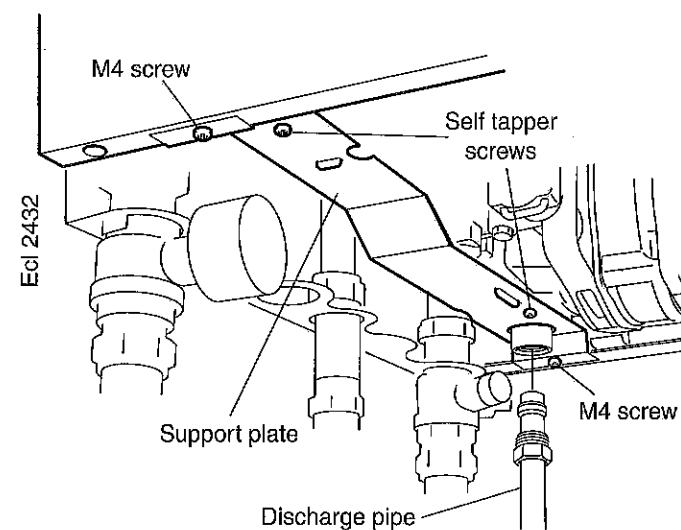

6. Withdraw the securing pin.
7. Remove the safety valve.
8. Fit the new safety valve and refit the securing pin.
9. Reassemble in reverse order, ensuring correct location of screws in support plate and that tabs on the pump and valve housings engage in slots.
10. Reconnect the discharge pipe.
11. Refill the boiler. Refer to Frame 28.
12. Check operation of the boiler. Refer to Frame 48.

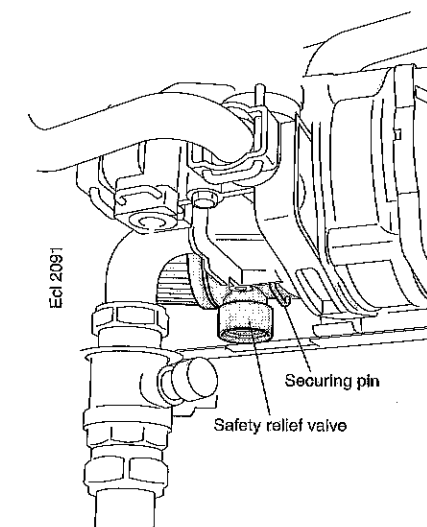

65 AUTOMATIC AIR VENT REPLACEMENT

1. Refer to Frame 48.
2. Remove the boiler front and sealing panels. Refer to Frames 40 & 41.
3. Drain the boiler. Refer to Frame 66.
4. Remove the turret from the boiler. Refer to Frame 24.
5. Release the silicone tubing from the sample point.
6. Release the electrical connections to the spark generator.
7. Remove the M5 nut retaining the flue casting spring clip and remove the spring clip.
8. Undo the 2 M5 x 10 flue spring clip retaining bracket screws and remove the bracket.
9. Remove the M5 x 10 screw, retaining the flue casting.
10. Remove the flue casting.
11. Unscrew the air vent from the extension pipe on the boiler boss.
12. Fit the new air vent, complete with 'O' ring provided, and reassemble in reverse order.

Note. In the event that the extension pipe is removed at the same time as the air vent, remove it from the air vent and refit it into the heat exchanger, ensuring that its 'O' ring seal is in place before fitting the new air vent.

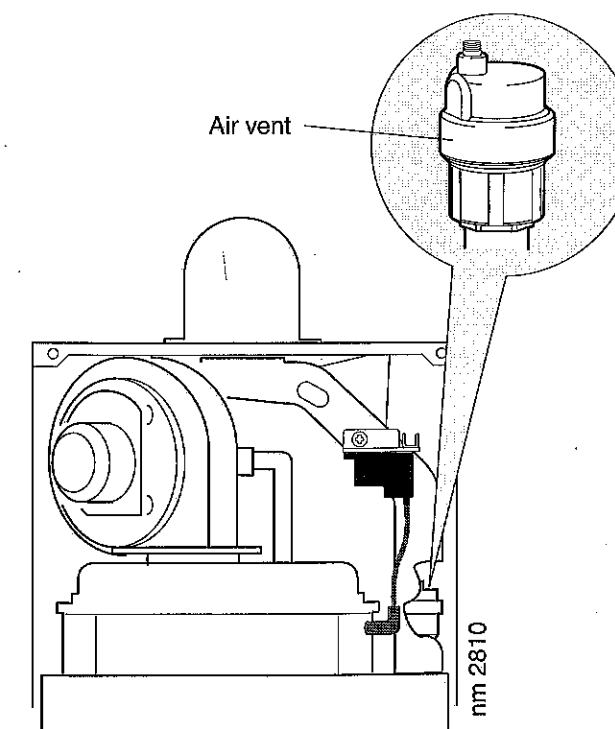

13. Refill the boiler. Refer to Frame 28.
14. Check operation of the boiler. Refer to Frame 48.

66 DRAINING THE BOILER

1. Refer to Frame 48.
2. Remove the boiler front and bottom panels. Refer to Frame 40 & 41.
3. Close all the water isolating valves on the piping frame.
4. Attach a length of hose to the drain point and open the drain valve.
5. **After replacing any component on the boiler, close the drain valve, remove the hose and open all system isolating valves, (and re-pressurise as appropriate) before proceeding to check operation of the boiler.**
6. Check operation of the boiler. Refer to Frame 48.

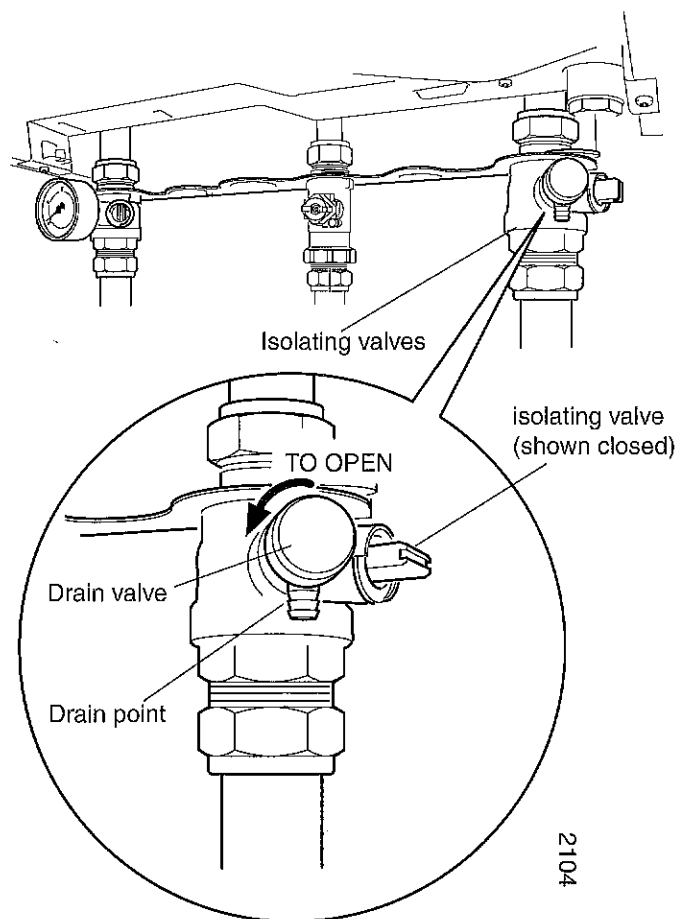

67 PUMP HEAD REPLACEMENT

1. Refer to Frame 48.
2. Remove the boiler front and bottom panels. Refer to Frame 40 & 41.
3. Drain the boiler. Refer to Frame 66.
4. Swing the control box down into the servicing position. Refer to Frame 42.
5. Disconnect the electrical lead from the pump.
6. Remove the 4 Allen screws retaining the pump head.
7. Remove the pump head.
8. Fit the new pump head.
9. Reassemble in reverse order.
10. Refill the boiler. Refer to Frame 28.
11. Check operation of the boiler. Refer to Frame 48.

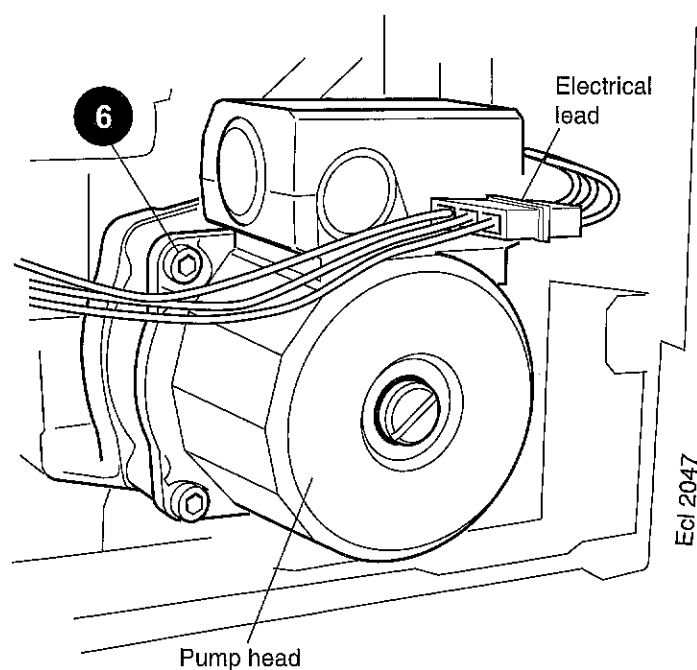

68 HEAT EXCHANGER REPLACEMENT

Refer also to Frames 7 & 8 - 'Boiler exploded view'.

IMPORTANT

Before starting the removal procedure, protect the gas and electrical controls with a waterproof sheet or plastic bag.

1. Refer to Frames 48.
2. Remove the boiler front, sealing and bottom panels. Refer to Frames 40 & 41.
3. Drain the boiler. Refer to Frame 66.
4. Remove the control box and place on one side. Refer to Frame 60.
5. Remove the fan / venturi assembly and place on one side. Refer to Frame 43.
6. Remove the burner and place on one side. Refer to Frame 44.
7. Remove the ignition and detection electrodes. Refer to Frames 54 & 55.
8. Remove the spark generator. Refer to Frame 56.
9. Release the flue from the turret. Refer to Frame 24.
10. Remove the turret from the boiler. Refer to Frame 24.
11. Release the silicon tubing from the sampling point.
12. Release the electrical connection to the dry fire thermistor.
13. Release the M5 nut retaining the flue casting spring clip and remove the spring clip.
14. Undo the 2 M5 x 10 flue spring clip retaining bracket screws and remove the bracket.
15. Remove the M5 x 10 screw retaining the flue casting.
16. Remove the flue casting.

17. Remove the automatic air vent complete with adapter. Refer to Frame 65.
 18. Remove the edge clip securing the flue thermistor wiring.
 19. Remove the blind grommet to gain access to the return pipe securing bracket.
 20. Remove the M5 screw and remove the return pipe securing bracket by sliding forwards.
 21. Remove the overheat thermostat and the control thermistor. Refer to Frame 53.
 22. Remove the securing pin to release the flow pipe.
 23. Remove the condensate 'S' trap. Refer to Frame 45.
 24. Remove the 2 M5 screws securing the interpanel to the back panel.
 25. Slide the heat exchanger and interpanel assembly upward to disengage and remove from the casing, complete with the return pipe.
 26. Remove the 2 M6 countersunk screws, remove the interpanel and transfer to the new heat exchanger.
 27. Remove the M5 screw and remove the flow pipe securing bracket.
 28. Remove the flow pipe and transfer to the new heat exchanger.
 29. Reassemble in reverse order, replacing gaskets or seals if any sign of damage or deterioration is evident.
- Note.**
The heat exchanger is supplied with new combustion chamber insulation boards. These should be fitted (refer to Frame 59) before the burner and fan / venturi assembly and before the ignition and flame detection electrodes are replaced.
30. Refill the boiler. Refer to Frame 28.
 31. Check operation of the boiler. Refer to Frame 48.

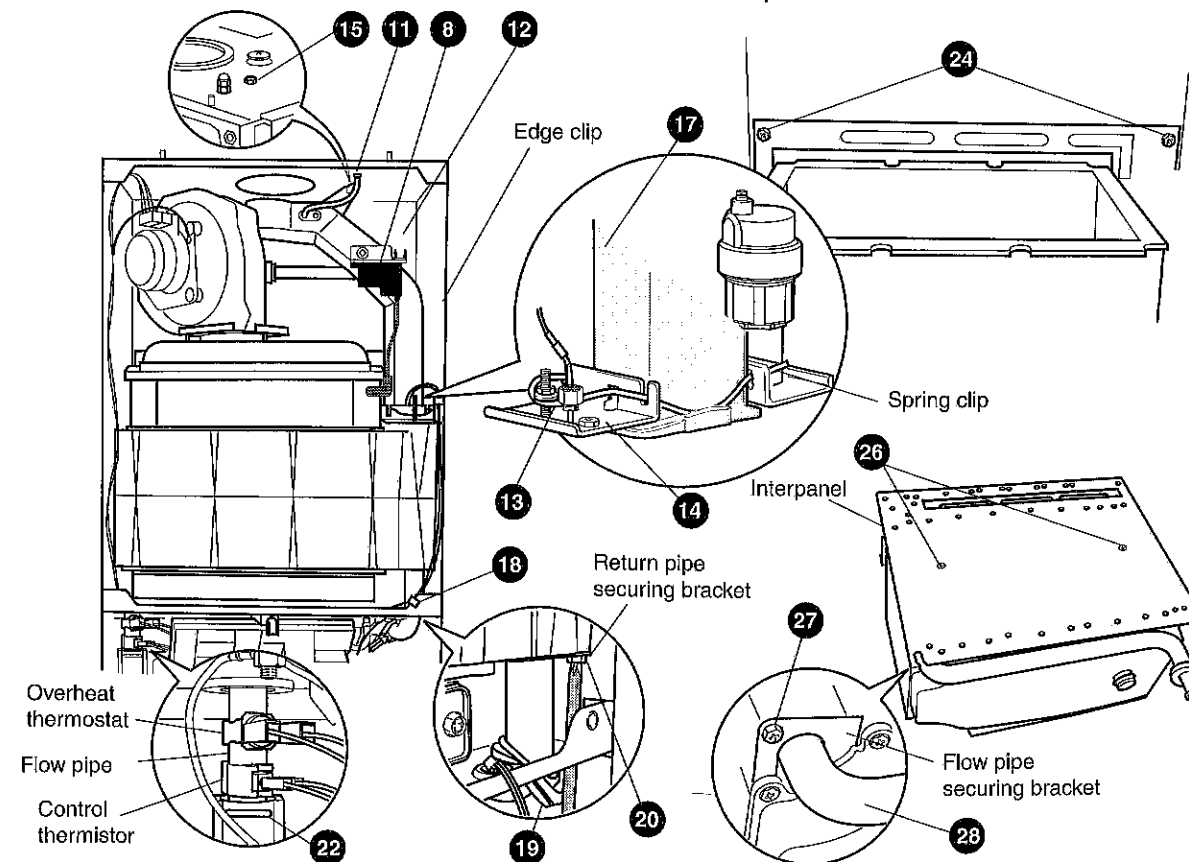

69 EXPANSION VESSEL REPLACEMENT

1. Refer to Frame 48 .
2. Drain the boiler. Refer to Frame 66.
3. Unscrew all the gas and water connection unions on the boiler side of the valves.
4. Remove the screw from the turret clamp and remove the turret.
5. Lift the complete boiler from the wall mounting frame and place on a flat surface, face down, to expose the expansion vessel.
6. Unscrew the union nut on the vessel water connection pipe.
7. Unscrew the 2 screws from the securing clamp and remove.
8. Remove the expansion vessel.
9. Fit the new expansion vessel.
10. Reassemble in reverse order.
11. Refill the boiler. Refer to Frame 28
12. Check operation of the boiler. Refer to Frame 48.

Note.
If preferred and for convenience, a new expansion vessel may be installed elsewhere in the heating system, providing it ensures equivalent system protection.

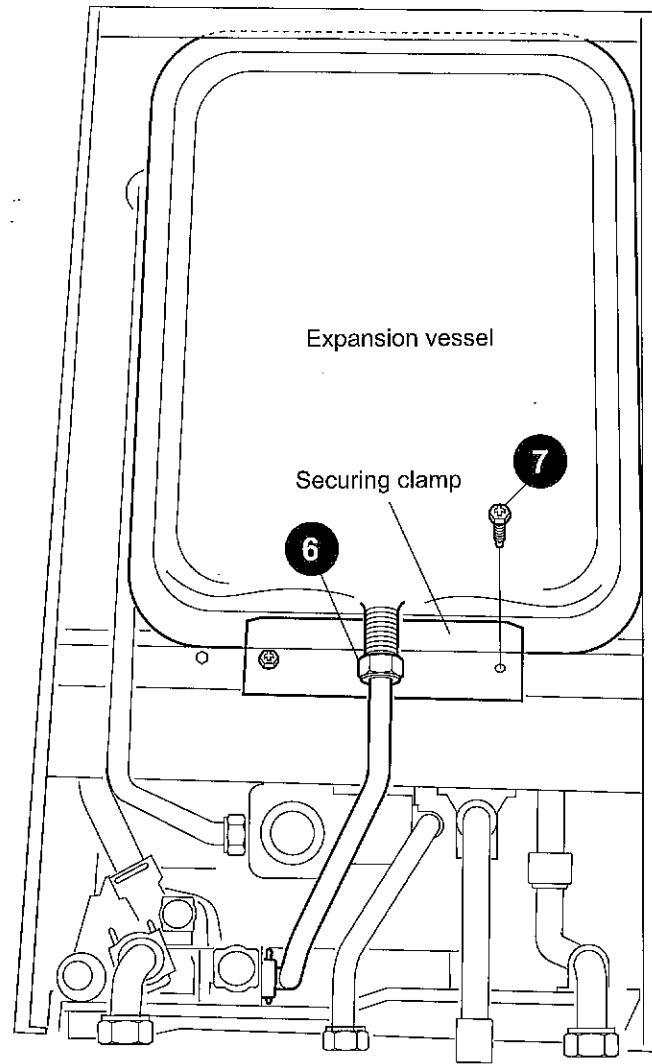

Rear view of the boiler

Edl 2537

70 BOILER SEALING PANEL SEAL REPLACEMENT

1. Refer to Frames 48.
2. Remove the boiler front and sealing panels. Refer to Frames 40 & 41.
3. Remove the old seal from the casing and thoroughly clean the casing surfaces.
4. Fit the new adhesive seals, noting that they are supplied to the correct length for the relevant sides.
5. Reassemble in reverse order.

Note. *Ensure that the boiler sealing panel is correctly seated, compressing the seal to make an airtight joint.*

6. Check operation of the boiler. Refer to Frame 48.

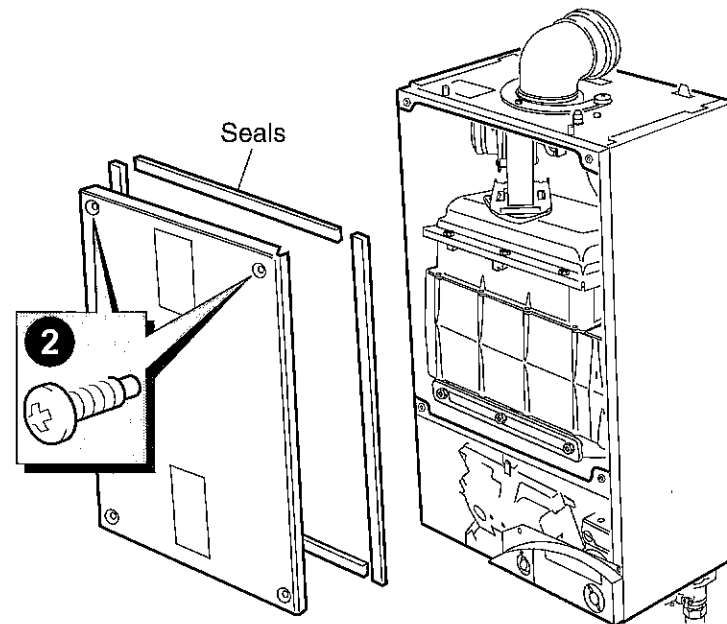

Edl 2812

71 FAULT FINDING CHART MAIN MENU

In order to assist fault finding the boiler has an LED diagnostic display. The key to the display codes is as follows:

ALTERNATING 'L' 'F'	GO TO FRAME 72
ALTERNATING 'L' 'E'	GO TO FRAME 73
ALTERNATING 'L' 'A'	GO TO FRAME 74
ALTERNATING 'L' '8'	GO TO FRAME 75
ALTERNATING 'H' '1'	GO TO FRAME 76
ALTERNATING 'H' '4'	GO TO FRAME 77
ALTERNATING 'H' 'F'	GO TO FRAME 78
ALTERNATING 'H' 'n'	GO TO FRAME 79
ALTERNATING 'H' 'E'	GO TO FRAME 73

FAULT FINDING

72 L.....F.... (FLAME DETECTION ERROR)

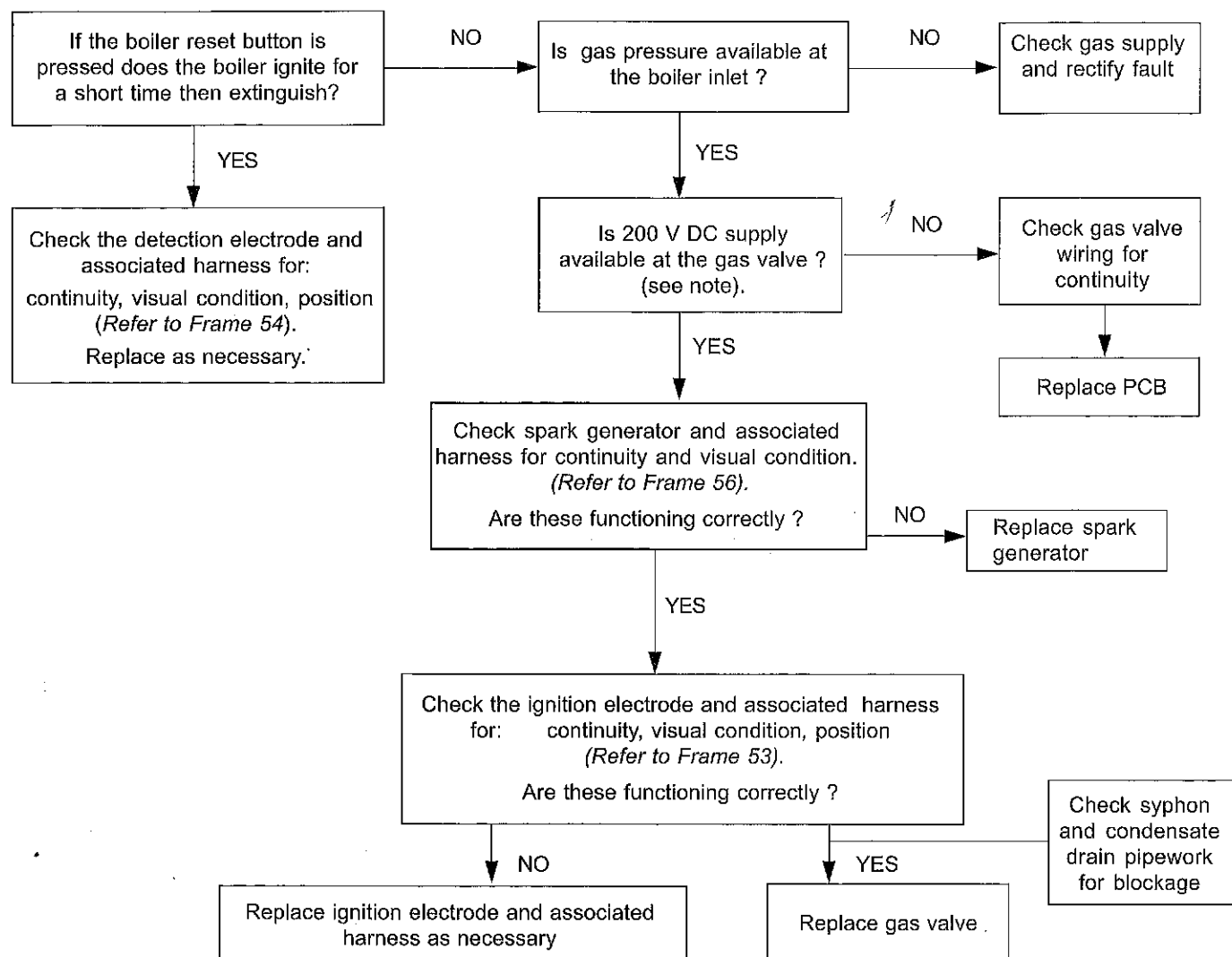

Note. Due to the wave form of the rectified voltage, the reading will vary depending on the type of meter used to measure the value (some may measure the possible peak voltage of 339V). In general terms a reading greater than 150V indicate that the correct voltage is supplied to the gas valve. As an alternative to a multimeter, a mains voltage checking device may be used. E.g. an electrical screwdriver or a mains tester.

73 L.....E.... or H.....E.... (BOARD ERROR)

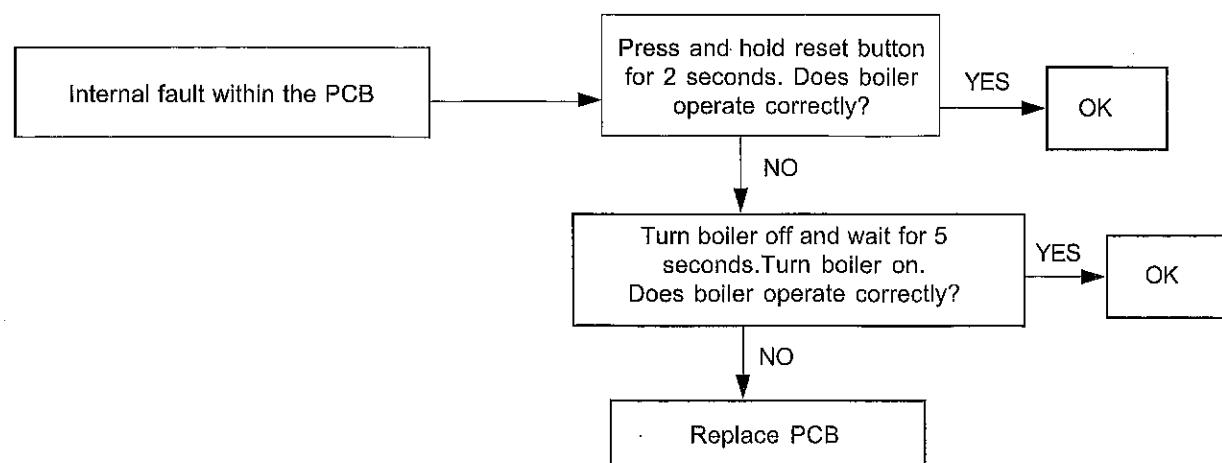

FAULT FINDING

74 L.....A..... (OVERHEAT ERROR)

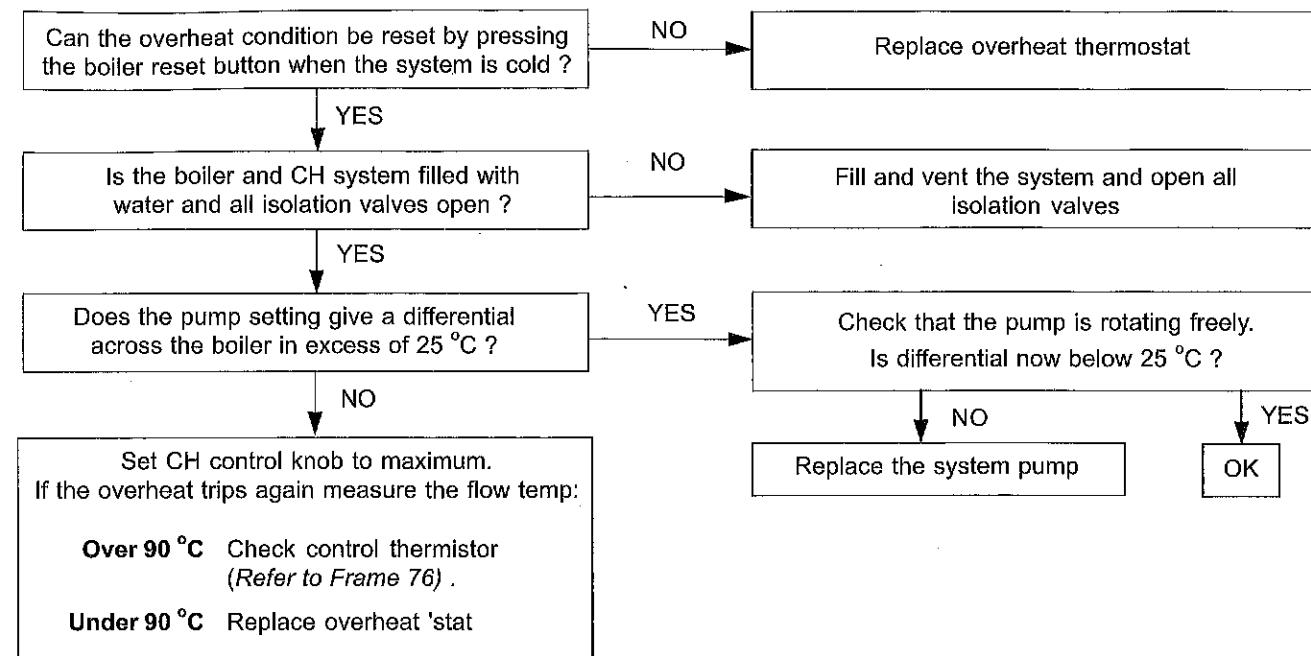

75 L....8..... (FAN ERROR)

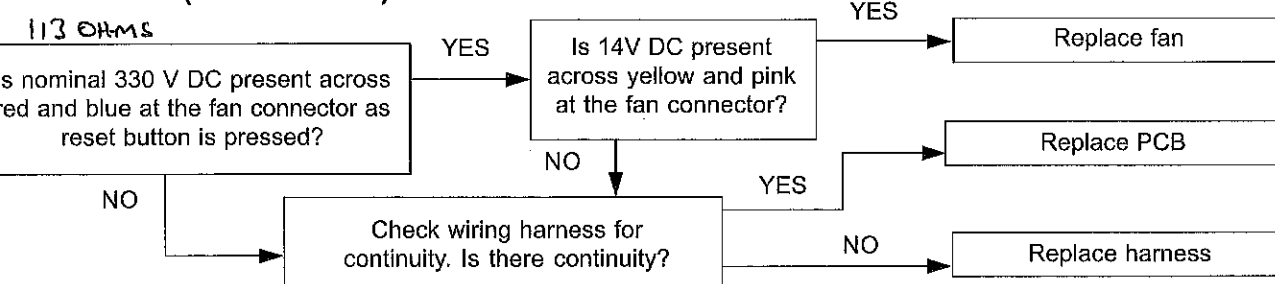

76 H.....1..... (CONTROL THERMISTOR ERROR)

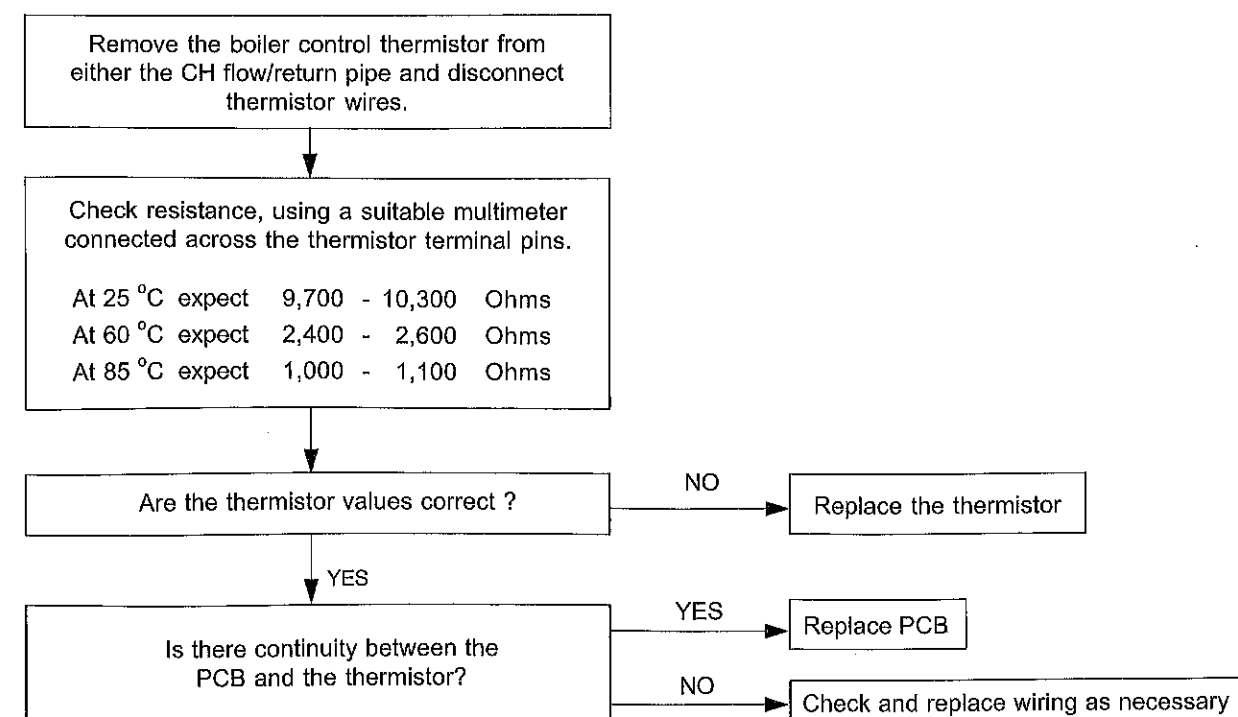

Check resistance, using a suitable multimeter connected across the thermistor terminal pins.

At 25 °C expect	9,700 - 10,300 Ohms
At 60 °C expect	2,400 - 2,600 Ohms
At 85 °C expect	1,000 - 1,100 Ohms

FAULT FINDING

77 H.....4..... (DRY FIRE THERMISTOR)

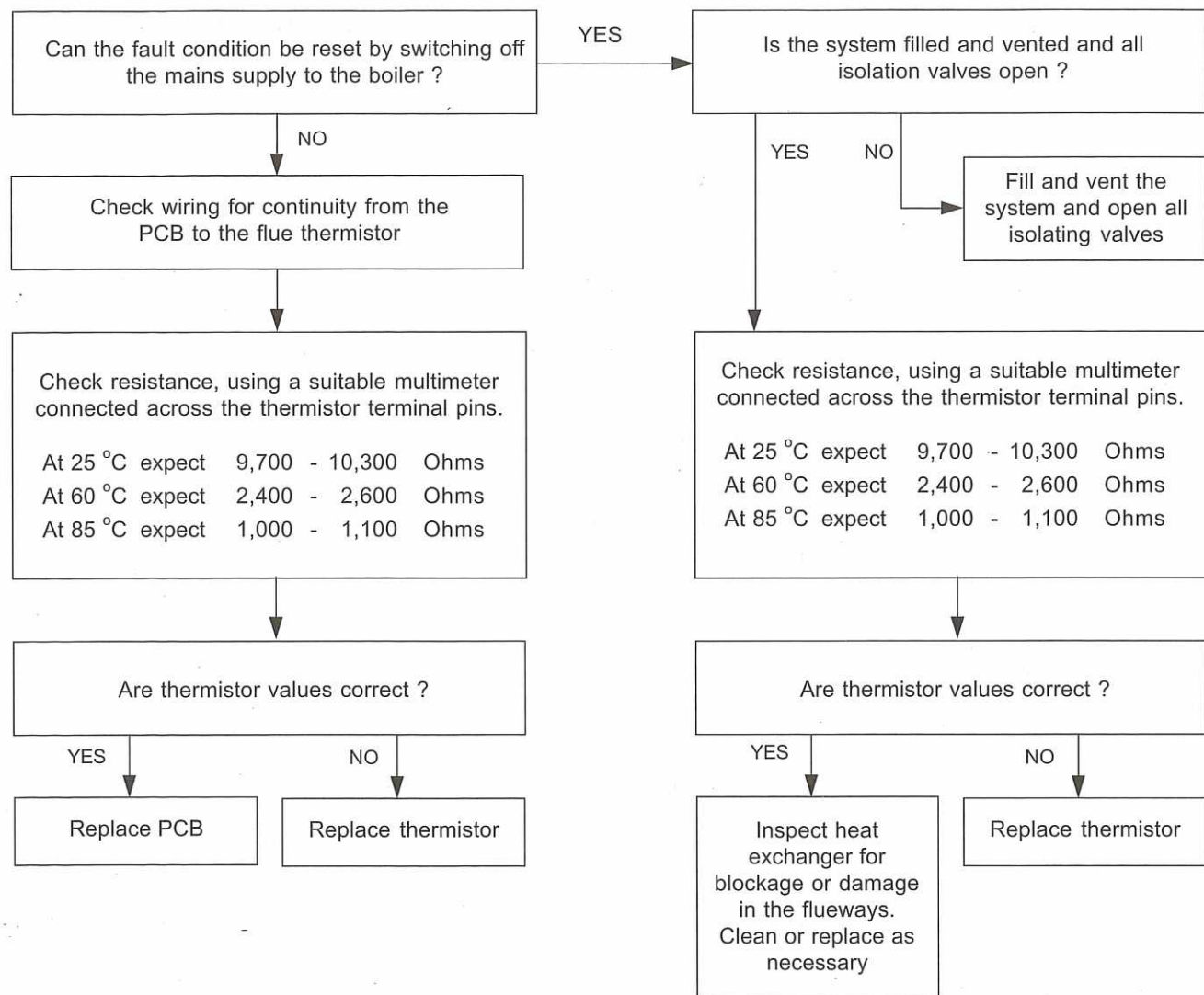

78 H.....F..... (FLAME DETECTION ERROR)

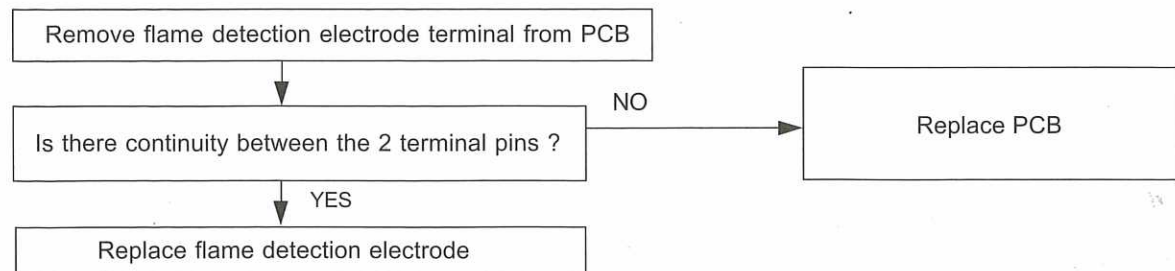

79 H.....n..... (PHASE REVERSAL ERROR)

H.3 No Links on PCB.

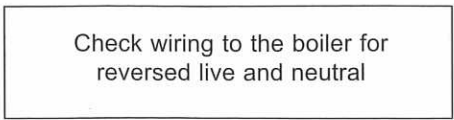

SHORT LIST OF PARTS

The following are parts commonly required due to damage or expendability. Their failure or absence is likely to affect safety or performance of this appliance.

The list is extracted from the British Gas List of Parts, which contains all available spare parts.

The full list is held by British Gas Services, Caradon Ideal Limited distributors and merchants.

When ordering spares please quote:

1. Boiler model
2. Appliance G.C. No.
3. Description.
4. Quantity.
5. Product number.

When replacing any part on this appliance use only spare parts that you can be assured conform to the safety and performance specification that we require. Do not use reconditioned or copy parts that have not been clearly authorised by Caradon Ideal Limited.

Key No.	G.C. Part No.	Description	Qty.	Product Number
1		Front casing panel	1	173 509
4	E69-384	Bottom casing panel	1	171 027
11	E67-489	Burner	1	170 905
12		Combustion chamber insulation	1	173 520
14	E67-492	Injector and housing	1	170 908
16	E85-097	Fan assembly	1	172 625
17	E69-286	Automatic air vent	1	170 988
19	E69-288	Gas control valve	1	171 035
23	E67-501	Control thermistor	1	170 917
24	E67-502	Overheat thermostat	1	170 918
25		Ignition electrode kit	1	173 528
26		Flame detection electrode kit	1	173 529
32	E67-511	Condensate 'S' trap	1	170 926
35		User control (display unit)	1	173 533
36		PCB primary controls (includes plastic housing)	1	173 534
37	E67-519	Fuse PCB (3.15AT L250V)	1	170 931
39	E67-521	Mains switch c/w harness	1	173 537
40		spark generator assy	1	173 538
45	E67-527	Gasket kit (servicing)	1	170 938
52	E68-376	Seal kit (sealing panel)	1	171 014
53	E68-380	Turret gasket	1	171 022
61	E69-338	Pressure relief valve	1	170 992
62	E69-339	Expansion vessel	1	173 066
64	E69-341	Pressure gauge	1	170 991
69	E69-342	Pump	1	170 990
94		Ignition lead	1	173 510
95		Detection lead	1	173 512
103		Dry fire thermistor	1	173 617

SHORT LIST OF PARTS

80 SHORT LIST

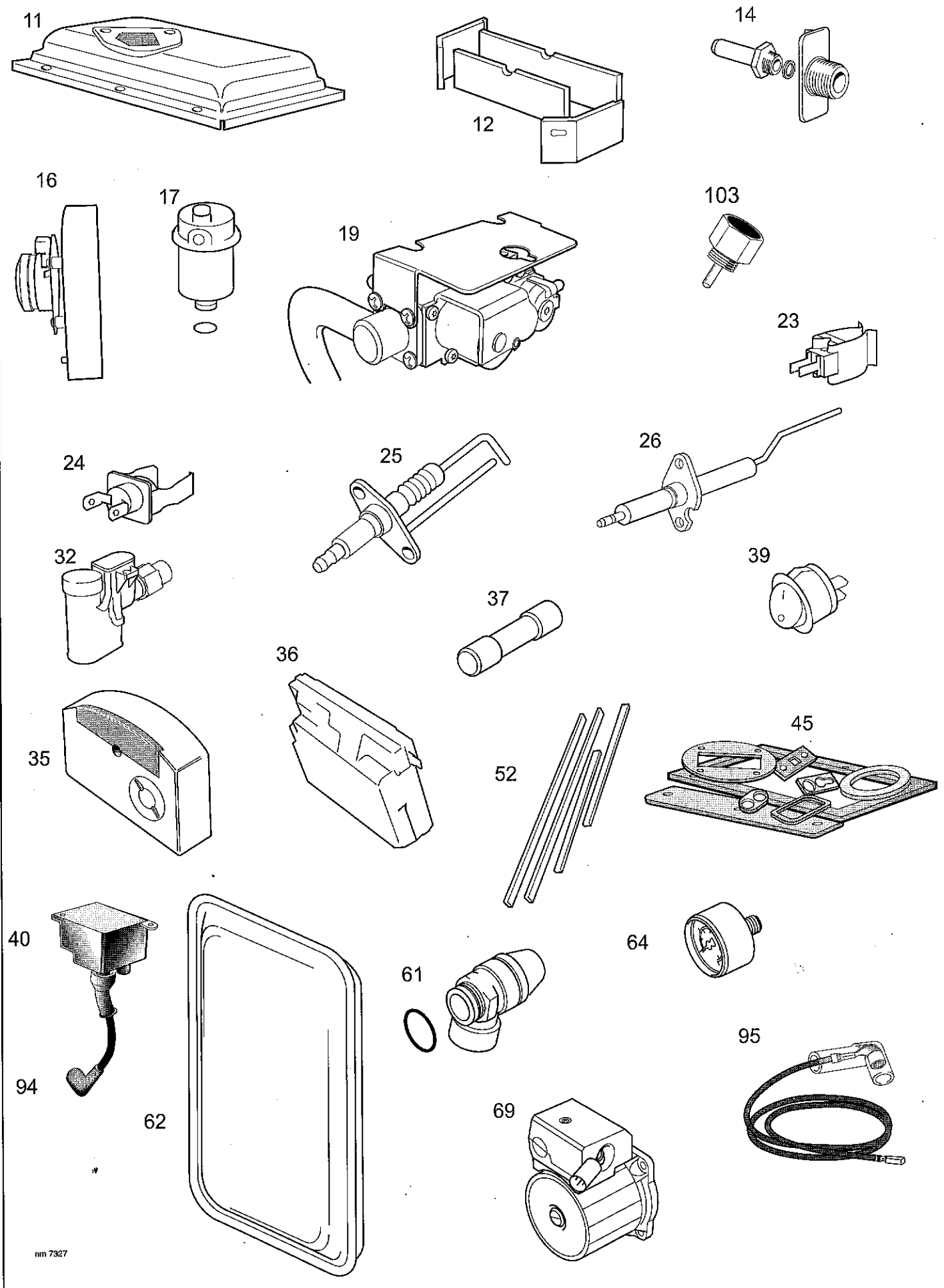

nm 7327

LIST OF PARTS

81 BOILER CASING ASSEMBLY

- 1. Front casing panel with screws.
- 2. Sealing panel with screws.
- 4. Bottom panel with screws.

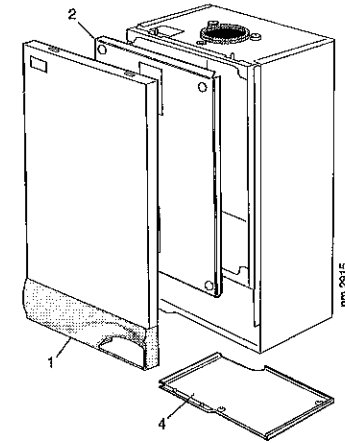

82 CONTROLS ASSEMBLY

- 33. Controls assy with screws.
- 34. Controls hinge bracket.
- 35. User controls (without item 38).
- 36. PCB (primary controls).
- 38. User controls housing
- 39. Mains switch.
- 54. Jumper link (not shown)

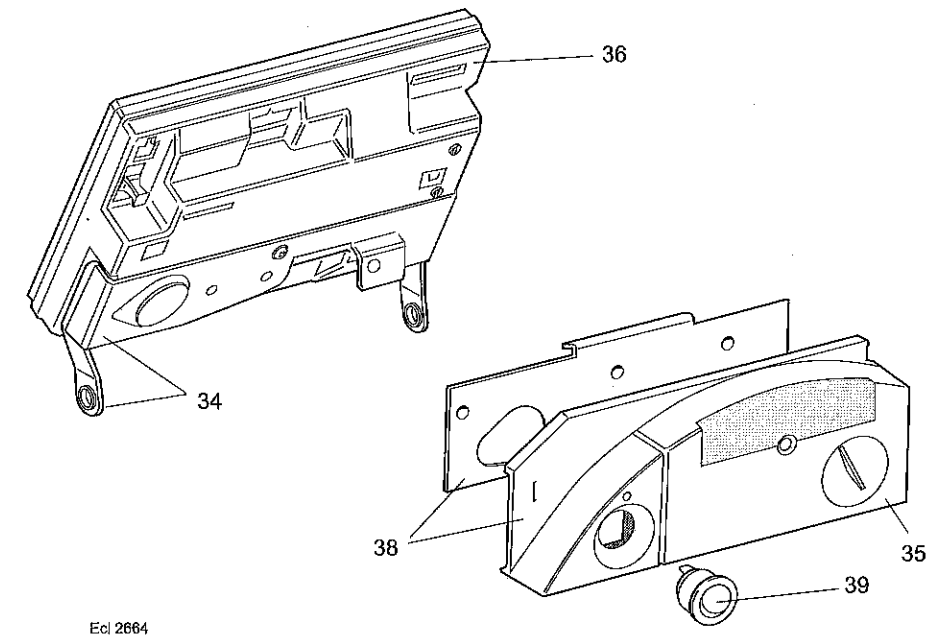

Ecl 2664

83 BURNER ASSEMBLY

- 11. Burner assembly with screws and gasket.

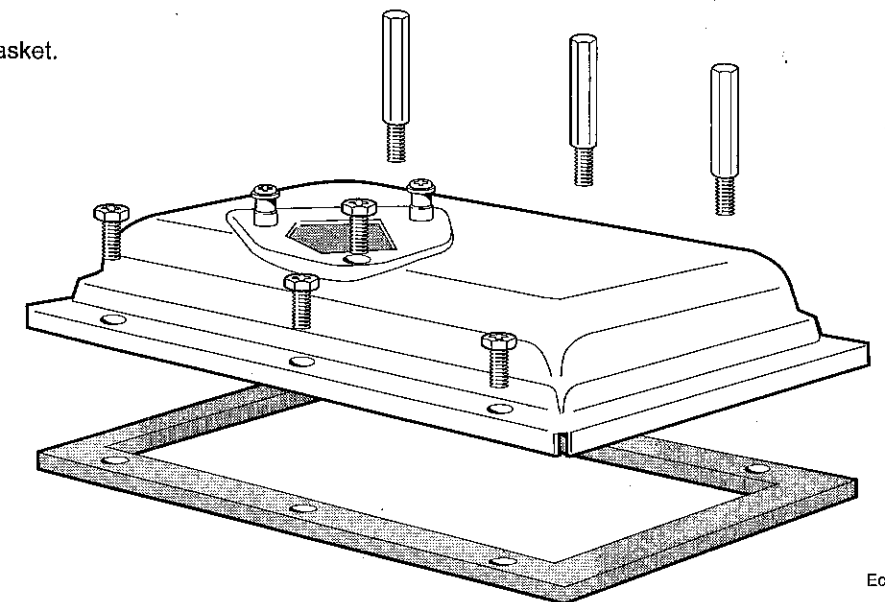

Ecl 1598



*The code of practice for the installation,
commissioning & servicing of central heating systems*

Technical Training

The Ideal Boilers Technical Training Centre offers a series of first class training courses for domestic, commercial and industrial heating installers, engineers and system specifiers.

For details of courses please ring: 01482 498 432



CERTIFIED PRODUCT
Manufactured under a BS EN ISO 9001:
2000 Quality System accepted by BSI

Ideal Boilers, P.O. Box 103, National Ave, Kingston upon Hull,
HU5 4JN. Telephone: 01482 492 251 Fax: 01482 448 858.
Registration No. London 322 137.

Caradon Ideal Limited pursues a policy of continuing improvement in the design and performance of its products. The right is therefore reserved to vary specification without notice.



i Ideal BOILERS
ENGINEERED FOR PEACE OF MIND

Caradon
Ideal Limited

Ideal Installer/Technical Helpline: 01482 498 663
www.idealboilers.com