

IDEAL W 2000

30 F, 40 F, 50 F & 60 F

Wall Mounted, Balanced Flue, Fanned, Gas Boilers

Installation & Servicing

CAUTION: To avoid the possibility of injury during the installation, servicing or cleaning of this appliance, care should be taken when handling edges of sheet steel components.

IMPORTANT: The appliances are for use with **NATURAL GAS ONLY.**

Ideal W 2000

30 F

40 F

50 F

60 F

G.C. Appliance No.

41 421 42

41 421 22

41 421 43

41 421 44

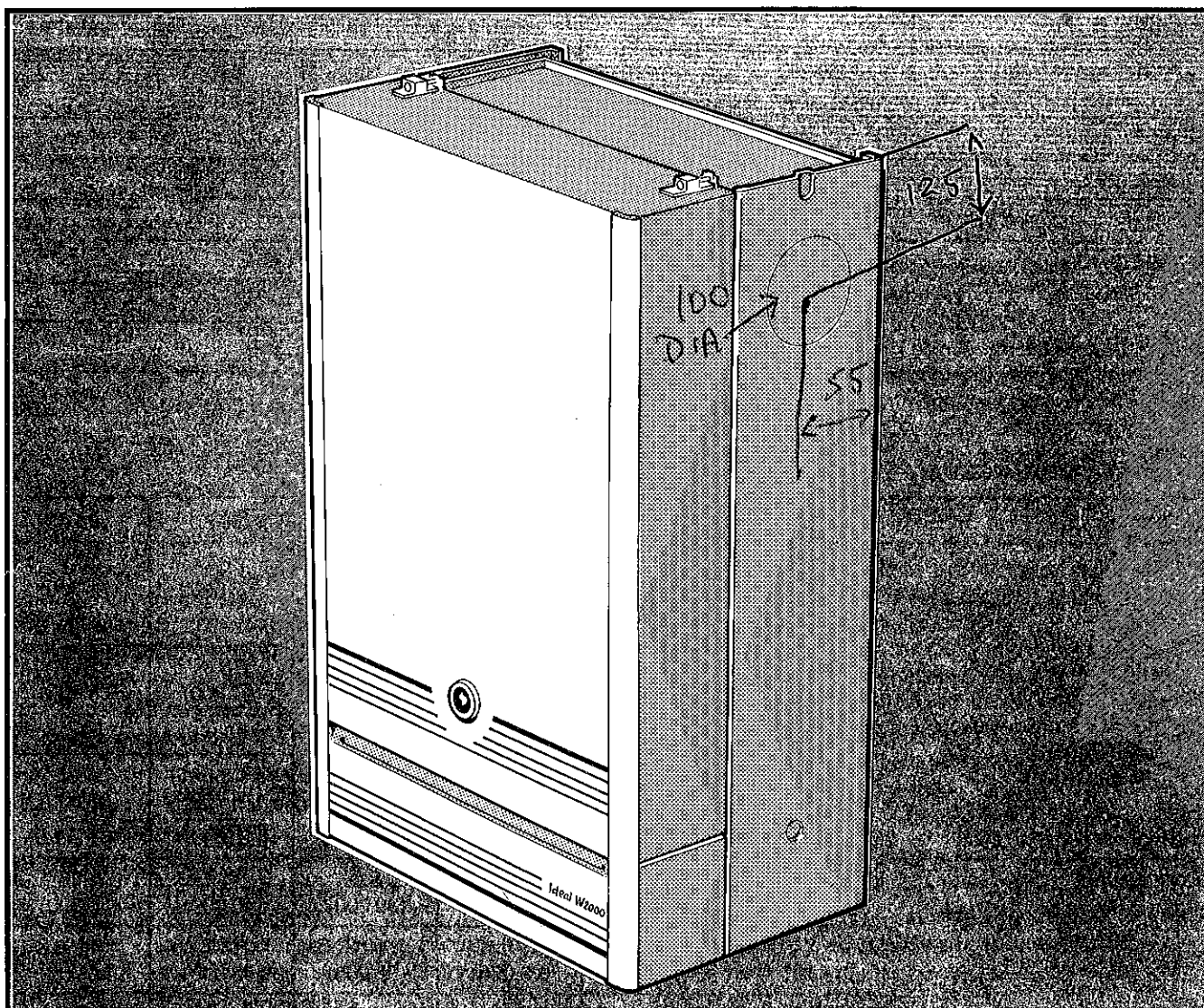

NOTE TO THE INSTALLER: LEAVE THESE INSTRUCTIONS ADJACENT TO THE GAS METER

Stelrad Ideal

GENERAL

PERFORMANCE DATA

Table 1- GENERAL DATA

Boiler Size		30 F	40 F	50 F	60 F
Main Burner Bar		AEROMATIC AC 19/123 241			AEROMATIC AC 19/123 239
Gas Control		HONEYWELL VR 4700E 1018, 240 V			
Burner Injector		BRAY 103 850	BRAY 103 1150	BRAY 103 1500	BRAY 103 1900
Pilot Injector		HONEYWELL 56/42A			
Gas Supply Connection		Rc 1/2 1/2			
Flow Connections		Rc 1 1			
Return Connections		Rc 1 1			
		Rc 3/4 3/4			
Maximum Static Water Head		m (ft) 30.5 (100)			
Minimum Static Water Head		m (ft) 0.45 (1.5)			
Electrical Supply		240 V ~ 50 Hz (Boiler power consumption 50W)			
Fuse Rating		external 3 A internal 1 A to BS. 4265			
Water Content		litre (gal.) 10.9 (2.4)			
Dry Weight		kg (lb) 76.5 (168)			
Maximum Installation Weight		kg (lb) 67 (147)			
Boiler size	Height	mm (in.) 840 (33)			
	Width	mm (in.) 490 (19.3)			
	Depth	mm (in.) 312 (12.3)			

Table 2- PERFORMANCE DATA

Boiler Size		30 F	40 F	50 F	60 F	
Boiler Input	MINIMUM	kW 7.8 (26 400)	11.7 (40 000)	16.3 (55 500)	20.7 (70 700)	
	To obtain gas consumption (a) In l/s, divide heat input (kW) by C.V of the gas (MJ/m³)	Gas Consumption	l/s (ft³/h) 0.2 (25.4)	0.3 (38.5)	0.42 (53.4)	0.53 (68)
		MID	kW 9.4 (32 100)	13.6 (46 300)	18.0 (61 300)	22.2 (75 800)
	(b) For Btu/h, divide heat, input (Btu/h) by C.V of the gas (Btu/ft³)	Gas Consumption	l/s (ft³/h) 0.24 (30.9)	0.35 (44.5)	0.46 (59)	0.57 (73)
		MAXIMUM	kW 11.2 (38 000)	15.3 (52 000)	19.6 (66 700)	23.7 (80 900)
	Heat inputs are pre-set to the highest nominal rating	Gas Consumption	l/s (ft³/h) 0.29 (36.6)	0.39 (50.0)	0.5 (64.2)	0.61 (77.9)
Boiler Output	MINIMUM	kW 5.8 (20 000)	8.8 (30 000)	11.7 (40 000)	14.6 (50 000)	
	MID	kW 7.3 (25 000)	10.3 (35 000)	13.2 (45 000)	16.1 (55 000)	
	MAXIMUM	kW 8.8 (30 000)	11.7 (40 000)	14.6 (50 000)	17.6 (60 000)	
Burner Setting Pressure (Hot)	MINIMUM	mbar 8.3 (in.w.g.) (3.3)	9.1 (3.6)	10.5 (4.2)	10.5 (4.2)	
	MID	mbar 11.6 (in.w.g.) (4.7)	12.2 (4.9)	12.2 (4.9)	11.9 (4.8)	
	MAXIMUM	mbar 15.0 (in.w.g.) (6.0)	15.4 (6.2)	14.2 (5.7)	13.4 (5.4)	

GENERAL GUIDANCE

INTRODUCTION

The Ideal W 2000 30F, 40F, 50F and 60F are fully automatically controlled, wall mounted balanced flue, fanned gas boilers. They are ranged rated to provide central heating outputs of 5.8 kW (20 000 Btu/h) to 8.8 kW (30 000 Btu/h), 8.8kW (30 000 Btu/h) to 11.7 kW (40 000 Btu/h), 11.7 kW (40 000 Btu/h) to 14.6 kW (50 000 Btu/h) and 14.6 kW (50 000) to 17.6 kW (60 000 Btu/h).

The boiler casing is of white enamelled mild steel as is the controls pod which contains a drop down door & a removable base.

The boiler thermostat is located, behind the controls access door, in the box mounted adjacent to the gas valve.

Programmer and pump kits, which fit neatly within the casing, are available as optional extras.

The pump kit is suitable for mounting on the right hand side flow tapping only. Separate fitting instructions are included with these kits.

The boilers are suitable, as standard, for connection to open vented systems ONLY. An optional extra kit is available to allow the boiler to be used on sealed water systems.

THE OPTIONAL PUMP KIT CANNOT BE USED IN CONJUNCTION WITH THE SEALED SYSTEM KIT, AN ALTERNATIVE PUMP ARRANGEMENT MUST BE INSTALLED.

The boiler is suitable for connection to pumped, open-vent central heating systems; pumped central heating combined with pumped, or gravity, indirect domestic hot water systems; gravity or pumped, indirect domestic hot water supply systems.

See Frame 4 for details of correct boiler tapping usage.

The boilers are supplied with a standard flue kit suitable for rear or side outlet applications from 114mm (4 1/2 in.) to 406mm (16 in.)

Optional extra extension ducts up to 2 m. (79 in.), rear or side outlet, are available.

A further optional kit is required to allow installation from inside the building.

Gas Safety (Installation and Use) Regulations, 1984

It is the law that all gas appliances are installed by competent persons (e.g. CORGI, identified by Ⓢ) in accordance with the above Regulations. Failure to install appliances correctly could lead to prosecution. It is in your own interest and that of safety, to ensure the law is complied with.

The installation of the boiler MUST also be in accordance with the latest I.E.E. Wiring Regulation, the Local Building Regulations, the by-laws of the Local Water Authority, the Building Regulations, the Building Standards (Scotland) and any relevant requirements of the Local Authority.

Detailed recommendations are contained in the following British Standard Codes of Practice.

- CP.331:3 Low pressure installation pipes
- BS.6798 Installation of gas fired hot water boilers of rated input not exceeding 60 kW
- BS.5449:1 Forced circulation hot water systems. (Smallbore and Microbore Domestic Central Heating Systems)
- BS.5546 Installation of gas hot water supplies for domestic purposes (2nd Family Gases)
- BS.5440:1 Flues (for gas appliances of rated input not exceeding 60 kW)
- BS.5440:2 Air Supply (for gas appliances of rated input not exceeding 60 kW)

Manufacturer's notes must NOT be taken, in any way, as over-riding statutory obligations.

IMPORTANT: These appliances are certified by the British Standards Institution for safety and performance. It is, therefore, important that no external control devices - e.g. flue

INTRODUCTION- GAS SUPPLY

dampers, economisers etc., are directly connected to these appliances- unless covered by these 'Installation and Servicing' instructions or otherwise recommended by Stelrad Group Ltd, in writing. If in doubt please enquire.

Any direct connection of a control device not approved by Stelrad Group Ltd, could invalidate the B.S.I. Certification, and the normal appliance warranty. It could also infringe the Gas Safety Regulations and the above Regulations.

LOCATION OF BOILER

The boiler MUST be installed on a flat and vertical external wall, capable of adequately supporting the weight of the boiler and any ancillary equipment.

The boiler may be fitted on a combustible wall and insulation between the wall and the boiler is not necessary- unless required by the Local Authority.

THE BOILER IS NOT SUITABLE FOR EXTERNAL INSTALLATION.

IMPORTANT NOTICE: If the boiler is to be fitted in a timber framed building it should be fitted in accordance with the British Gas publication 'Guide for Gas Installations in Timber Frame Housing,' Reference DM2. If in doubt advice must be sought from the Local Gas Region of British Gas.

The boiler may be installed in any room or internal space, although particular attention is drawn to the requirements of the current I.E.E. Wiring Regulations and, in Scotland, the electrical provisions of the Building Regulations applicable in Scotland, with respect to the installation of a boiler in a room or internal space containing a bath or shower.

Where a room-sealed appliance is installed in a room containing a bath or shower, then the appliance and any electrical switch or appliance control, utilising mains electricity should be so situated that it cannot be touched by a person using the bath or shower.

Where installation will be in an unusual location, special procedures may be necessary and BS.6798 gives detailed guidance on this aspect.

A compartment used to enclose the boiler MUST be designed and constructed specially for this purpose. An existing cupboard, or compartment, may be used provided it is modified for the purpose. Details of essential features of cupboards/ compartment design, including airing cupboard installation are given in BS.6798.

In siting the boiler, the following limitations MUST be observed.

1. The position selected for installation MUST allow adequate space for servicing in front of the boiler and for air circulation around the boiler. For minimum clearances required for safety and subsequent service see wall mounting template & Frame 8. In addition sufficient space may be required to allow lifting access onto the wall mounting plate.
2. This position MUST also permit the provision of a satisfactory balanced flue termination.

GAS SUPPLY

The Local Gas Region should be consulted, at the planning stage, in order to establish the availability of an adequate supply of gas. An existing service pipe must not be used without prior consultation with the Local Gas Region.

A gas meter can only be connected by the Local Gas Region, or by a Local Region Contractor.

An existing meter should be checked, preferably by the Gas Region to ensure the meter is adequate to deal with the rate of gas supply required.

Installation pipes MUST be fitted in accordance with CP.331:3 Pipework from the meter to the boiler MUST be of an adequate size. Do NOT use pipes of a smaller size than the boiler inlet gas connection.

The complete installation MUST be tested for gas soundness and purged as described in the above Code.

GENERAL GUIDANCE

FLUEING

Detailed recommendations for flueing are given in BS.5440:1

The following notes are intended for general guidance:

- The boiler must be installed so that the terminal is exposed to the external air.
- It is important that the position of the terminal allows free passage of air across it at all times.
- The minimum acceptable spacings from the terminal to obstructions and ventilation openings are specified in Table 3.
- Where the lowest part of the terminal is fitted less than 2m (6.6ft) above a balcony, above the ground, or above a flat roof, to which people have access then the terminal MUST be protected by a purpose designed guard. Terminal guards are available from:
Quinnel, Barret & Quinnel Limited
884 Old Kent Road, LONDON SE15; MODEL P2 or
Tower Flue Components Ltd
Vale Rise, Tonbridge, KENT TN9 1TB; MODEL B
Ensure that the guard is fitted centrally.

Table 3

Terminal Position	Minimum Spacing
1. Directly below an openable window, air vent or any other ventilation opening.	300 mm (12 in.)
2. Below guttering, drain pipes or soil pipes.	75 mm (3 in.)
3. Below eaves.	200 mm (8 in.)
4. Below balconies or a car port roof.	200 mm (8 in.)
5. From vertical drain pipes or soil pipes.	75 mm (3 in.)
6. From internal or external corners.	300 mm (12 in.)
7. Above adjacent ground, roof or balcony level.	300 mm (12 in.)
8. From a surface facing the terminal.	600 mm (24 in.)
9. From a terminal facing a terminal.	1200 mm (48 in.)
10. From an opening in a car port (eg. door or window) into dwelling.	1200 mm (48 in.)
11. Vertically from a terminal on the same wall.	1500 mm (60 in.)
12. Horizontally from a terminal on the wall.	300 mm (12 in.)

- Where the terminal is fitted within 850 mm (34 in.) of a plastic or painted gutter, or 450 mm (18 in.) of painted eaves, an aluminium shield at least 750 mm (30 in.) long should be fitted to the underside of the gutter or painted surface.
- The air inlet/ products outlet duct and the terminal of the boiler MUST NOT be closer than 25 mm (1 in.) to combustible material.
Detailed recommendations on the protection of combustible materials are given in BS.5440:1 1978, sub-clause 20:1

IMPORTANT: It is absolutely ESSENTIAL to ensure, in practice, that products of combustion discharging from the terminal cannot re-enter the building, or any other adjacent building, through ventilators, windows, doors, other sources of natural air infiltration or forced

FLUING- AIR SUPPLY

ventilation/ air conditioning.

If this should occur, the appliance MUST be turned OFF immediately and the Local Gas Region consulted.

TERMINAL

The terminal assembly of the fanned balanced flue can be adapted to accommodate various wall thicknesses- refer 'Packaging'.

AIR SUPPLY

Detailed recommendations for air supply are given in BS.5440:2. The following notes are intended for general guidance:

- It is NOT necessary to have a purpose provided air vent in the room or internal space in which the boiler is installed.
- If the boiler is to be installed in a cupboard or compartment, permanent air vents are required (for cooling purposes) in the cupboard/ compartment, at both high and low levels.
The air vents MUST either communicate with a room/ internal space, or be direct to outside air.
The minimum effective areas of the permanent air vents, required in the cupboard/compartment, are specified below and are related to the maximum rated heat input of the boiler.

Table 4- 30 F

Position of air vent	Air from room/ internal space	Air direct from outside
HIGH LEVEL cm ² (in ²)	100 (16)	50 (8)
LOW LEVEL cm ² (in ²)	100 (16)	50 (16)

Table 5- 40 F

Position of air vent	Air from room/ internal space	Air direct from outside
HIGH LEVEL cm ² (in ²)	133 (21)	67 (11)
LOW LEVEL cm ² (in ²)	133 (21)	67 (11)

Table 6- 50 F

Position of air vent	Air from room/ internal space	Air direct from outside
HIGH LEVEL cm ² (in ²)	166 (26)	83 (13)
LOW LEVEL cm ² (in ²)	166 (26)	83 (13)

Table 7- 60 F

Position of air vent	Air from room/ internal space	Air direct from outside
HIGH LEVEL cm ² (in ²)	200 (30)	100 (16)
LOW LEVEL cm ² (in ²)	200 (30)	100 (16)

GENERAL GUIDANCE

Note: Both air vents MUST communicate with the same room or internal space or must both be on the same wall to outside air.

WATER CIRCULATION SYSTEM

The boiler must NOT be used for direct hot water supply. For the types of system and correct piping procedure- see introduction and frame 4.

Note: All water connections MUST be made to the boiler REAR tappings.

The central heating system should be in accordance with the relevant recommendations given in BS.5376:2 and, in addition, for Smallbore and Microbore systems - BS.5449:1.

The domestic hot water system, if applicable, should be in accordance with the relevant recommendations of BS.5546. Copper Tubing, to BS.2871:1 is recommended for water carrying pipework.

The hot water storage cylinder MUST be of the indirect type and should, preferably, be manufactured of copper. Single-feed indirect cylinders are not recommended, and MUST NOT be used on sealed systems.

The appliances are NOT suitable for gravity central heating with, or without, additional gravity domestic hot water supply, nor are they suitable for the provision of gravity domestic hot water requirements above a 181.8 litre (40 gal.) tank capacity, depending on the model.

The hot water cylinder and ancillary pipework, not forming part of the useful heating surface, should be lagged to prevent heat loss and any possible freezing- particularly where pipes run through roof spaces and ventilated under floor spaces.

The boiler MUST be vented. If venting cannot be done via a flow connection, then a separate vent MUST be fitted by the installer. This does NOT mean that more than one open air vent is required. Other parts of the system, which may become unavoidably air locked, can be automatically vented.

Draining taps MUST be located in accessible positions, which permit the draining of the whole system, including the boiler and hot water storage vessel. These taps should be, at least 1/2 in B.S.P. nominal size and be in accordance with BS.2879.

WATER CIRCULATION- ELECTRICAL SUPPLY

The hydraulic resistances of the boilers, at MAXIMUM OUTPUT, with an 11°C (20°F) temperature differential, are shown in Table 8.

Table 8- WATER FLOW RATE AND PRESSURE LOSS

Boiler Size	30 F	40 F	50 F	60 F
Boiler Output kW	8.8	11.7	14.7	17.6
Btu/h	30 000	40 000	50 000	60 000
Water Flow l/min	11.4	15.2	19.0	22.8
Rate gal/h	150	200	250	300
Pressure mbar	15.0	27	39	51
Loss in.wg	6.0	10.8	15.6	20.5

ELECTRICAL SUPPLY

Wiring external to the appliance MUST be in accordance with the current I.E.E. Wiring Regulations and any Local Regulations which apply.

The boiler is supplied for 240 V ~ 50 Hz Single Phase.

Fuse Rating is 3 A

The method of connection to the mains electricity supply MUST facilitate complete electrical isolation of the boiler, preferably by the use of a fused, unswitched three pin plug and a shuttered socket-outlet, both complying with the requirements of BS.1363

Alternatively, a fused double-pole switch, having at least a 3mm (1/8 in.) contact separation in both poles and servicing only the boiler, may be used.

The point of connection to the mains should be readily accessible and adjacent to the boiler, except that, for bathroom installations, the point of connection to the mains MUST be situated outside the bathroom.

NOTE: Where a room sealed appliance is installed in a room containing a bath or shower, the appliance, any electrical switch or appliance control utilising mains electricity should be so situated that it cannot be touched by a person using the bath or shower.

1 UNPACKING The boiler is supplied fully assembled in one pack ('A') together with a standard flue assembly for lengths up to 406mm (16in), rear or side flue outlet, in pack 'B'. Optional extras, if ordered, (Pump Kit, Programmer Kit, Overheat Thermostat Kit, Inside Installation Kit (Pack 'E') & Extension Duct Kits ('B1' & 'D')) are available in separate boxes. Unpack and check the contents.

PACK 'A' CONTENTS Also contained in Pack 'A'; the Hardware Pack (listed opposite), these Installation & Servicing Instructions, the User's Instructions & an electrical mains plug.

HARDWARE PACK
 Distributor tube, 1 off.
 Thermostat pocket, 1 off.
 1 in. BSP, recessed plugs, 5 off.
 8 mm x 50 mm coach screws, 3 off.
 50 mm x No. 10 wood screw, 9 off.
 Wall plug (TP3 blue), 3 off.
 Wall plug (TP28 brown), 9 off.
 Data plate indicator arrow, 1 off.
 Square bar, 1 off.
 M5 nuts, 4 off.
 M4 x 10 lg. screws, 4 off.
 M6 wing nuts, 2 off.
 Roll of sealing tape, 1off.
 Spacer sleeve for rear outlet only, 1 off

Side concealment panels c/w sealing discs, sealing plates & M6 nuts

Wall mounting plate

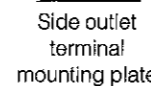
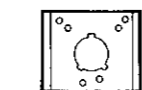

Side outlet terminal mounting plate

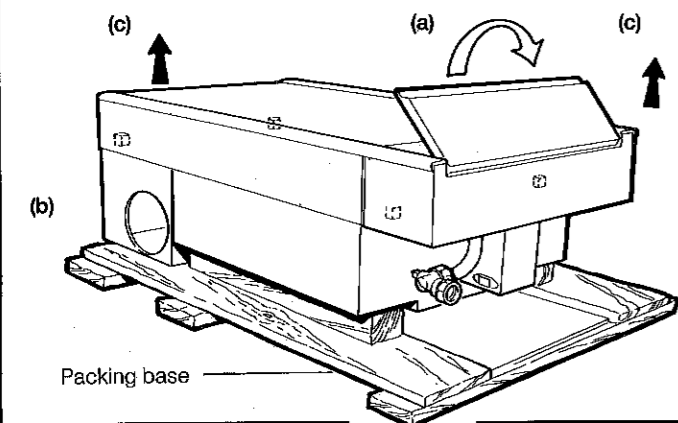
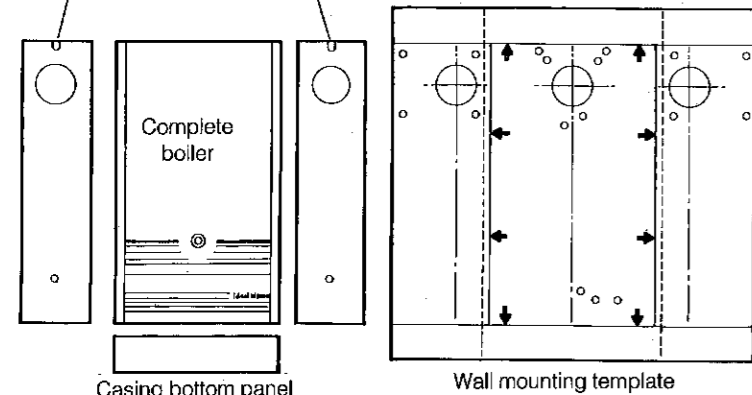

1. Unpack the boiler.
 2. Remove the casing as follows and place to one side to avoid damage.
- CASING REMOVAL SEQUENCE**
- (a) Open the controls pod door- unhinge & remove.
 - (b) Undo the 4 screws retaining the casing to the back panel
 - (c) Remove the casing in the direction of the arrows.

PACK 'B' CONTENTS Also contained in Pack 'B'; 3.2 mm Dia. drill, 1 off; No. 8 x 6 mm self tappers, 8 off; length of adhesive tape, 1 off; duct cutting support rings, 2 off (cardboard- retain for later use).

PACK 'E' CONTENTS
 For installation from the inside of the building only.

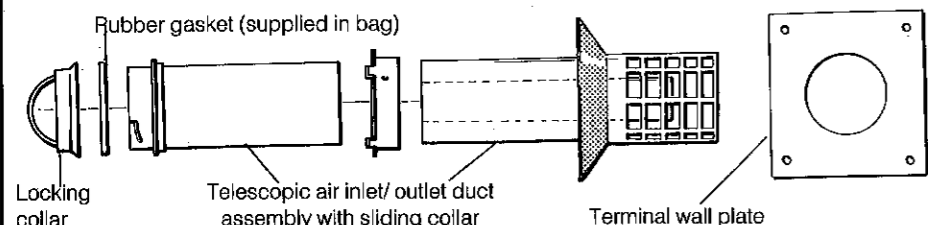

2 PACKAGING AND CASING REMOVAL

1. Unplug the fan connection at the fan plate. Slacken the two lower fan plate screws and remove the top two fan plate screws and washers. Remove fan plate assembly.

2. Remove the side flue extension tube (taped inside the fan chamber)

3. Remove the two bolts and large sealing plates securing the boiler to the packaging base. **Note:** Retain sealing plates for wall mounting purposes

5. Unpack the boiler terminal box and, if applicable, the extension flue box(es).

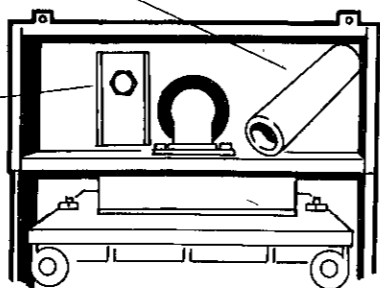
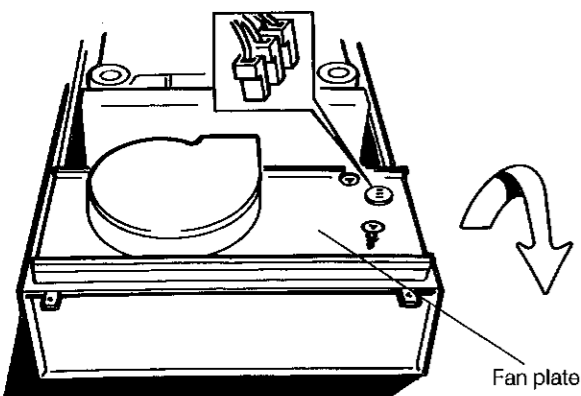

3 BOILER ASSEMBLY- Exploded view

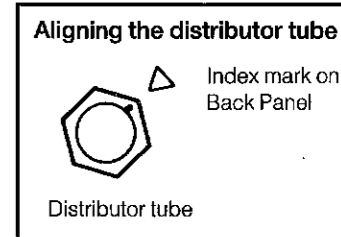
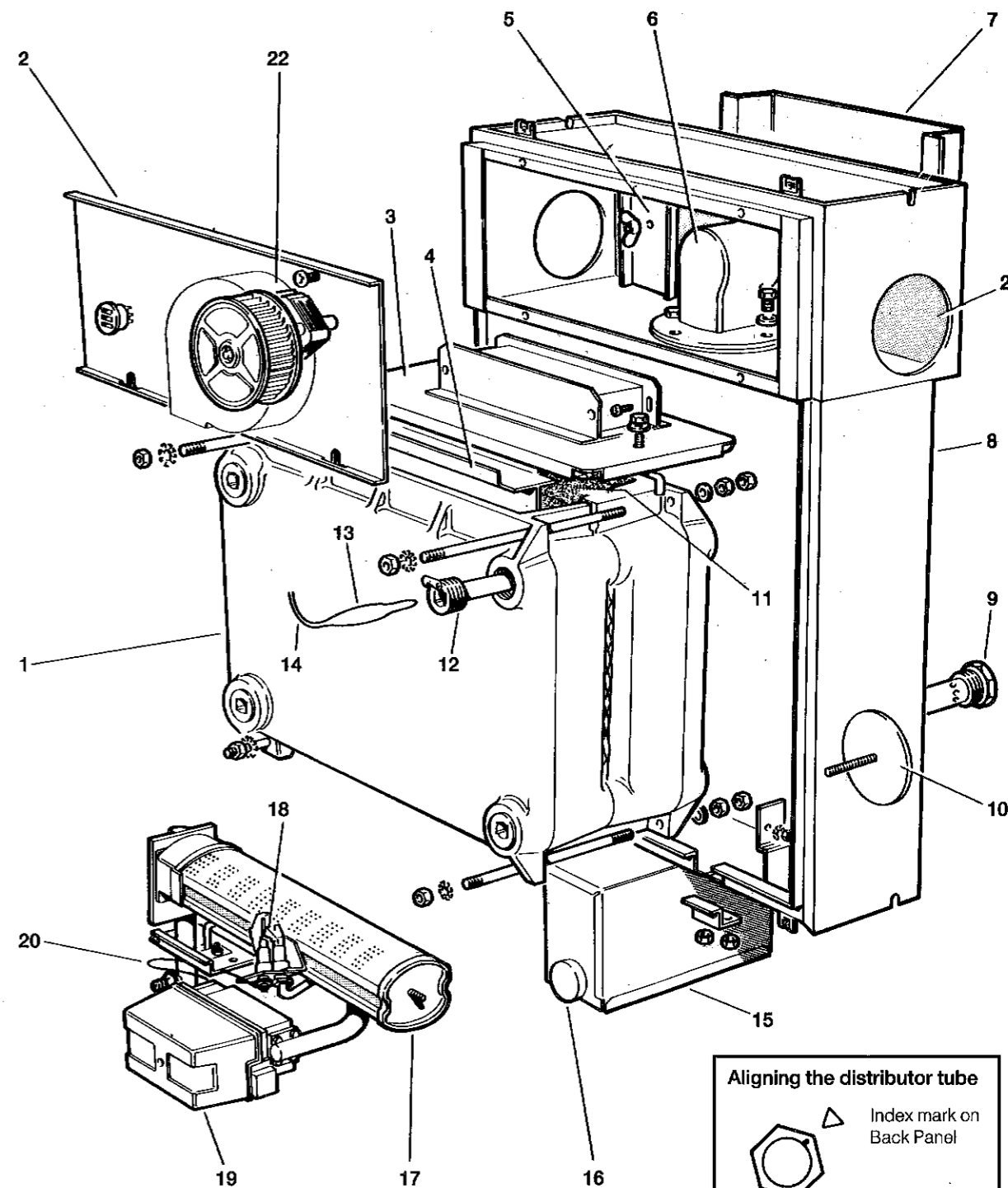

LEGEND

- | | |
|--|---|
| 1. Heat exchanger assembly | 12. Boiler thermostat pocket (left or right) |
| 2. Fan plate assembly | 13. Boiler thermostat phial |
| 3. Clean- out cover assembly | 14. Thermostat capillary |
| 4. Flueway baffle | 15. Control box |
| 5. Sealing plates (2 off) | 16. Boiler thermostat |
| 6. Flue outlet elbow | 17. Main burner |
| 7. Wall mounting plate | 18. Pilot burner assembly |
| 8. Back panel | 19. Gas control valve |
| 9. Distributor tube (left or right, one side only) | 20. Thermocouple lead |
| 10. Jacking plate | 21. Side flue aperture (option of rear, left or right hand flue outlet) |
| 11. Heat exchanger flue | 22. Fan assembly |

INSTALLATION

SYSTEM DESIGN

4 BOILER WATER CONNECTIONS (Open vented systems)

- Use approved jointing compound for all water connections.
- This appliance is NOT suitable for use in a direct hot water system.
- If the boiler is to be used on a sealed system, an optional extra kit is available and must be installed in accordance with the instructions supplied with the kit.

All water connections must be made to the REAR tappings. The distributor tube MUST be fitted to the HEATING return. Ensure that the index mark on the tube is aligned with the arrow on the boiler back panel, refer to Frame 2. The thermostat pocket MUST be fitted to the FRONT top tapping at the SAME SIDE of the boiler as the distributor tube.

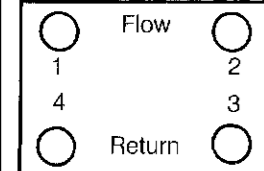

SCHEMATIC REAR VIEW OF BOILER, Showing boiler flow & return tappings

For Sealed System applications (fully pumped) - refer to the 'Sealed System Kit Instructions'.

SYSTEM REQUIRED	TAPPINGS TO BE USED
Fully Pumped (Pump kit fitted)	Flow 1 Return 3 or 4
Fully Pumped (External Pump)	Flow 1 or 2 Return 3 or 4
Pumped CH (Pump Kit Fitted) & Gravity HW	Flow 1 Return 4 Flow 2: Return 3
Pumped CH (External Pump) & Gravity HW	Flow 1 or 2 Return 4 or 3 Flow 1: Return 4 Flow 2: Return 3
Pumped CH Only (Pump Kit Fitted)	Flow 1 Return 3 or 4
Pumped CH Only (External Pump)	Flow 1 or 2 Return 3 or 4
Gravity HW Only	Flow 1: Return 4 or Flow 2: Return 3

5 MINIMUM REQUIREMENTS- (Fully pumped, open vented systems)

- Open vent & cold feed connections are made to the boiler flow/return tappings as shown.
- The boiler is assumed to be the highest point of the circulating system.
- The circulation pump is positioned on the FLOW. The vertical distance, between the pump & the feed/expansion tank, complies with the Pump Manufacturer's minimum requirements - to avoid cavitation. Should these conditions not apply, either lower the pump position, or raise the feed/expansion tank above the minimum requirements of Stelrad Group Ltd..
- The water velocity through the boiler flow/return pipes is assumed to be below 1 m/s (3 ft/s), whilst the pump flow rate is set to provide a temperature difference of 11°C (20°F) across the boiler flow/return, at design input.
- This information is intended as a GUIDE ONLY and cannot take into account instantaneous changes in head caused by the operation of motorised valves, pump etc. Due allowance MUST be made if surging is liable to occur.

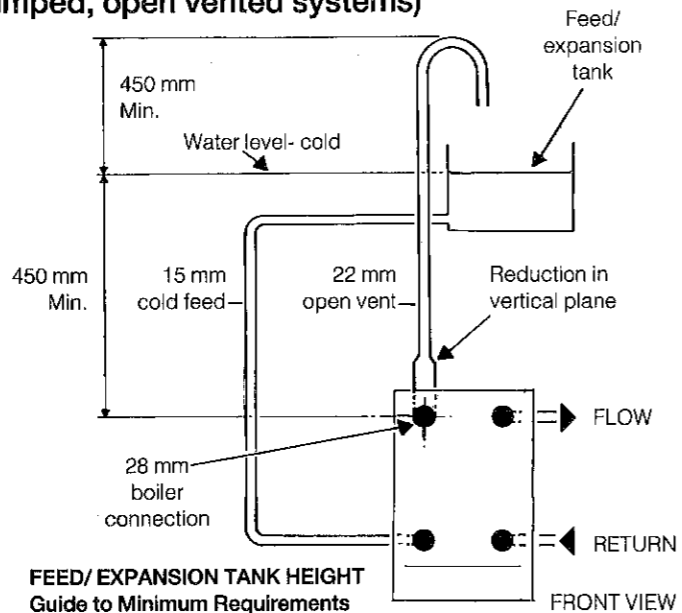

FEED/ EXPANSION TANK HEIGHT Guide to Minimum Requirements

6 REQUIREMENTS FOR CORRECT GRAVITY HOT WATER PERFORMANCE

Note: Gravity horizontal pipes should be ABOVE ceiling level and as SHORT as possible. A MINIMUM inclination of 25 mm per 3m run (1 in per 10 ft) is required to avoid air locks. If these conditions cannot be met, pumped primaries MUST be used.

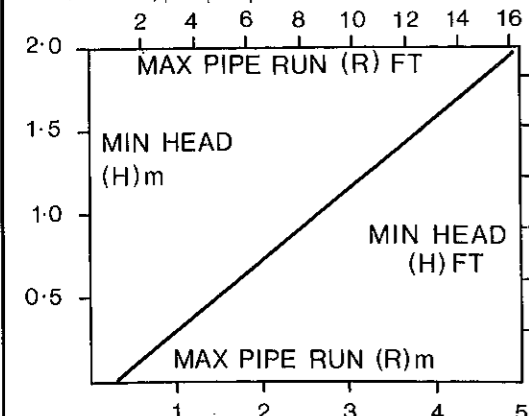

The above graph assumes 8 elbows in the gravity circuit. For each elbow in excess of 8 (R) must be reduced by 300 mm (12in) or (H) increased by 100 mm (4 in).

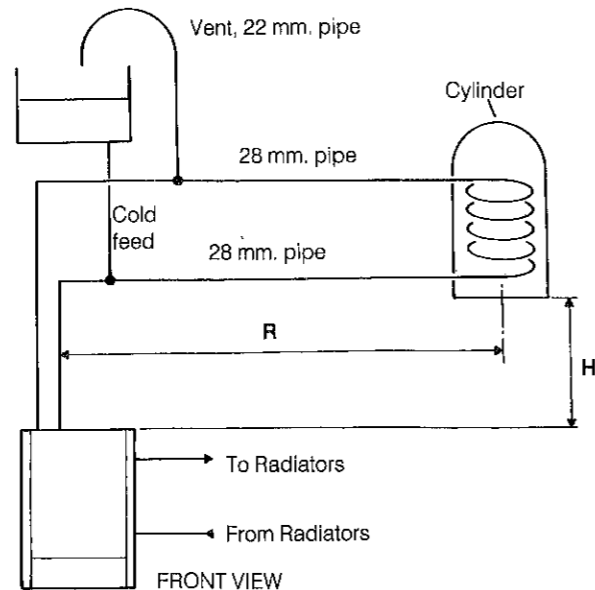

FRONT VIEW

INSTALLATION

BOILER DIMENSIONS/ PREPARATION- FLUE LENGTH

7 BOILER DIMENSIONS/ SERVICES

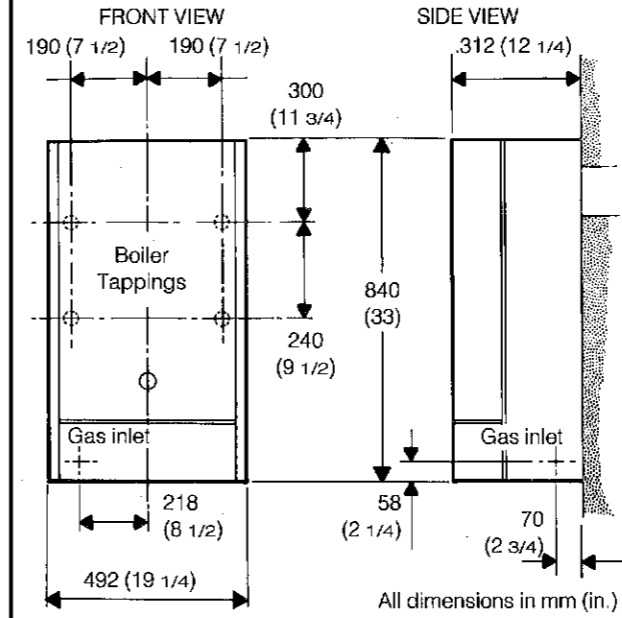

8 BOILER CLEARANCES

The following minimum clearances must be maintained for operation & servicing. Additional space will be required for installation, depending upon site conditions.

Notes, (Side flue only):

- For flue lengths greater than the width of the boiler the space in which the boiler is to be installed must be at least equal to the flue length plus the length of the terminal grille. **INSTALLATION FROM INSIDE ONLY.**
- If a core boring tool is to be used inside the building, the space in which the boiler is to be installed must be at least wide enough to accommodate the tool.

All dimensions in mm (in.)

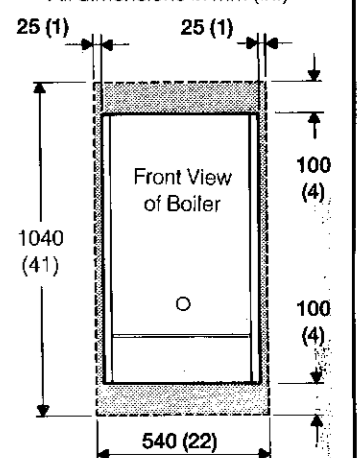

Front clearance: 450 mm (17 3/4 in.) from front of boiler casing.

9 PREPARING THE BOILER

1. Fit the distributor tube to the chosen pumped heating return connection (align the index mark on the tube with the arrow on the back panel, refer to Frame 3). Note: If optional pump is to be fitted, do so at this stage. Up to the point of fitting boiler on the wall, refer to separate instructions supplied with the kit.

- Fit thermostat pocket to upper front tapping on SAME side as distributor tube.
- Fit the stub connections for the heating flow & return, and gravity flow & return, if required. If the side clearance is limited, ensure the stub connections are continued upwards or downwards to clear the top or bottom of the boiler casing. To fit the boiler casing the gas & water connections MUST run within the space enclosed. However, removable sections in the side concealment panels allow water service pipes to run horizontally from the boiler. Cut edges with Hacksaw & twist to remove. Note: cutouts must not be used for sealed systems & cannot be used for the optional pump kit. Ensure pipes run horizontally, allowing the concealment panels to be fitted correctly.

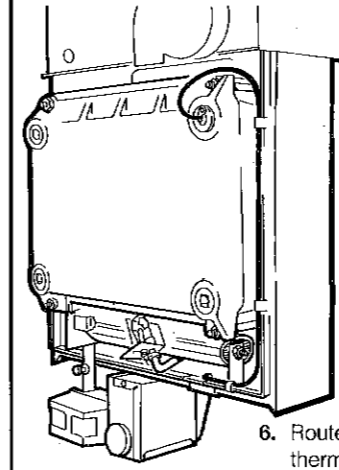

- Plug spare tappings with the recessed plugs, provided.
- If the boiler is to be fitted on a sealed system- refer to the Sealed System Kit Instructions (position of thermostat phial).

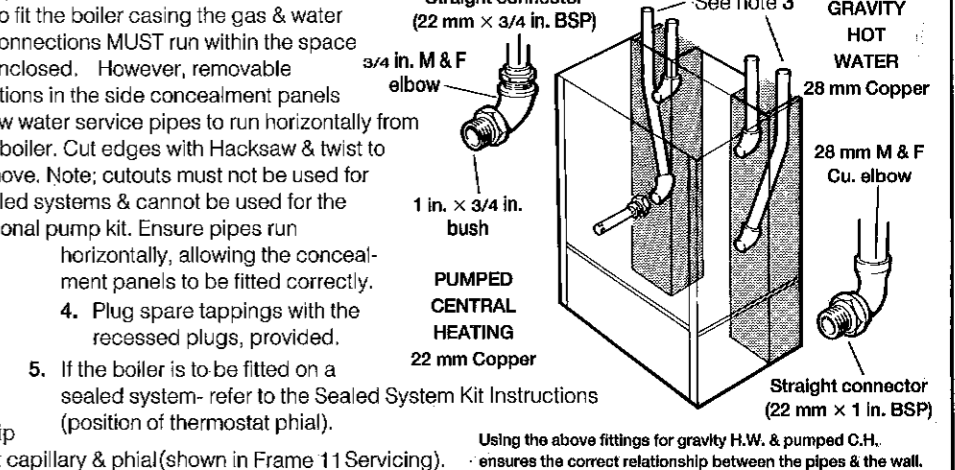

10 DETERMINING THE FLUE LENGTH

It is most important that the boiler is installed in a vertical position

Dimension 'X'- is the wall thickness

Dimension 'Y'- is the wall thickness plus boiler spacing

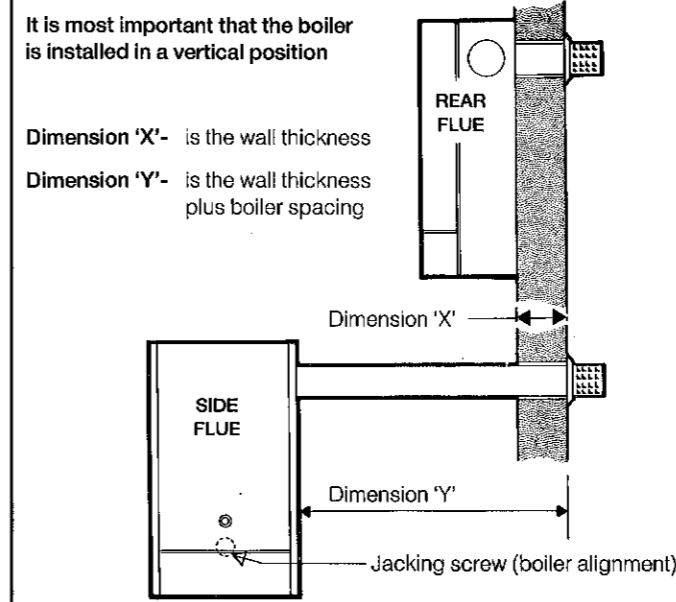

Flue kits:

- Pack 'B' - supplied as standard
- Pack 'B1' - optional extension kit, refer to Frame 40
- Pack 'D' - optional extension kit for side flue or rear flue outlet, refer to Frame 41
- Pack 'E' - optional internal installation kit, refer to Frame 1

FLUE LENGTH		Flue Packs required
Dimension 'X'	Dimension 'Y'	
114 - 206 mm (4.5 - 8.1 in.)	114 - 216 mm (4.5 - 8.5 in.)	Pack B (cut down as in Frames 15 and 28)
206 - 396 mm (8.1 - 15.6 in.)	216 - 406 mm (8.5 - 16 in.)	Pack 'B'
396 - 600 mm (15.6 - 23.6 in.)	406 - 610 mm (16 - 24 in.)	Pack 'B' & Pack 'B1' (Frame 40)
600 - 1990 mm (23.6 - 78.3 in.)	610 - 2 m (24 - 79 in.)	Pack 'B' & 2 off pack 'D' (Frame 41)

11 FLUE ASSEMBLY- Exploded View

- Notes:**
1. An optional duct extension kit is required for wall thicknesses greater than 406 mm (16 in.)- refer to Frames 40 & 41.
 2. An optional wall sleeve kit is required for installation from inside the building- refer to Frame 1.
 3. When cutting the ducts always use the cardboard support rings provided

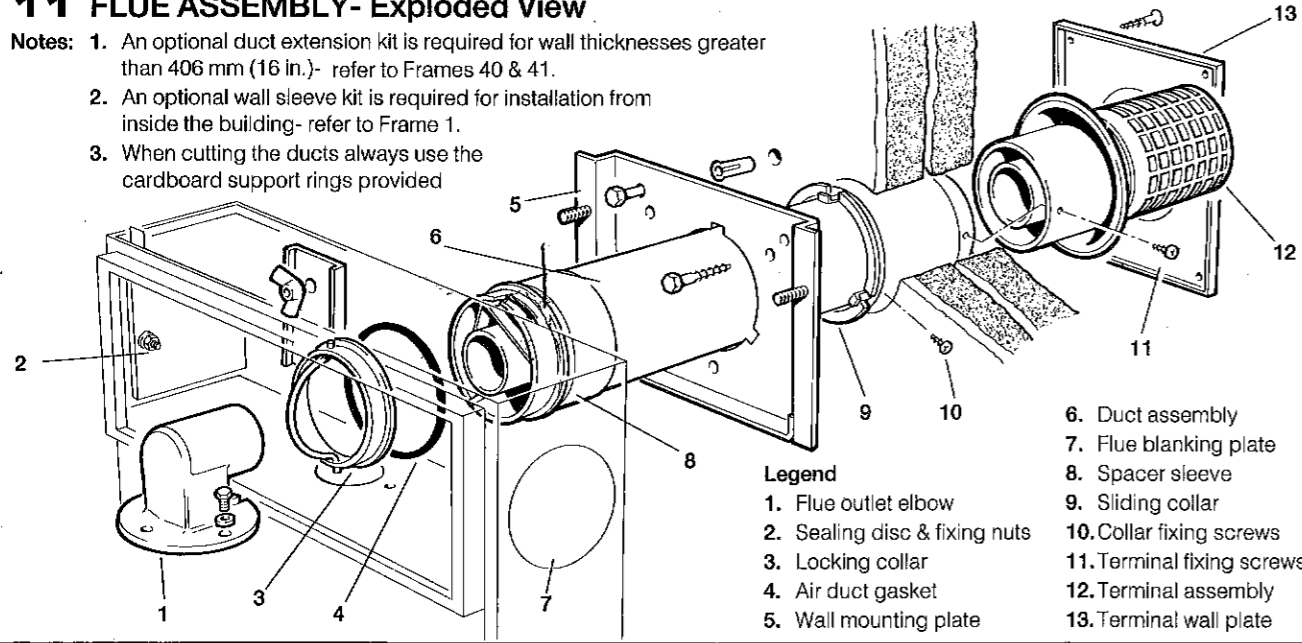

12 WALL MOUNTING TEMPLATE

1. Discard both sections 'B' of template.
2. Tape the template into the selected position.

3. Ensure squareness by hanging a plumb line as shown.

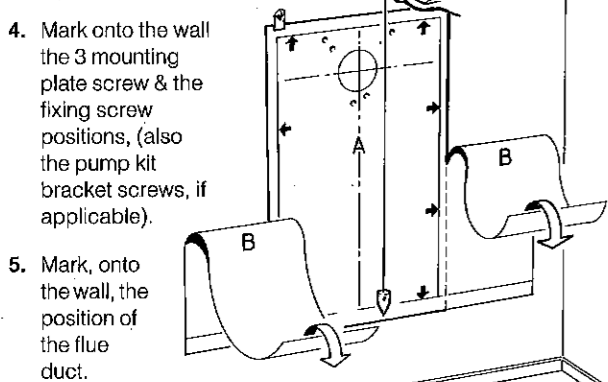

4. Mark onto the wall the 3 mounting plate screw & the fixing screw positions, (also the pump kit bracket screws, if applicable).
5. Mark, onto the wall, the position of the flue duct. **Note:** Mark the centre of the hole as well as the circumference.

6. Remove the template from the wall.

13 PREPARING THE WALL

IMPORTANT: Ensure that, during the cutting operation, masonry falling outside of the building does not cause damage or injury.

1. Cut the flue hole preferably with a 5 in core boring tool, ensuring the hole is square to the wall



2. Measure the wall thickness, 'X'.
3. Drill the 3 fixing holes with a 10 mm (3/8 in.) masonry drill.

4. Drill the jacking plate fixing screw hole with an 8 mm (5/16 in.) masonry drill.
5. If applicable drill the pump bracket holes.
6. Insert the plastic plugs provided.

NOTE: Check all hole positions before drilling.

14 WALL SLEEVE- For installation from INSIDE the building only

1. Cut the sleeve to length ('X' - 10 mm).
2. Slide into the wall opening as shown.

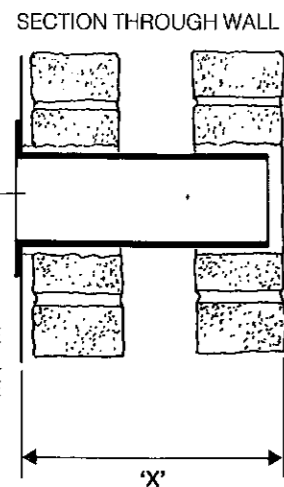

3. Make good at the inside end & at the outside end by reaching through the sleeve.

Note: Maximum wall thickness- 620 mm (24.4 in.).

15 CUTTING THE DUCT ASEMBLY

For wall thicknesses of 114 mm (4.5 in.) to 206 mm (8.1 in.) ONLY, [Flue Pack 'B'].

1. Separate the duct assembly
2. Fit the spacer sleeve, move the sliding collar to the end of duct & measure off dimension 'X'.

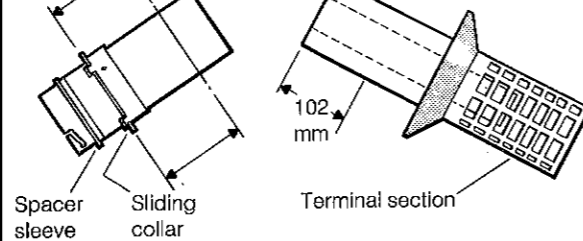

3. Cut to length 'X' using cardboard duct support rings. **Note:** Cut inner flue tube 6 mm (1/4 in.) longer than air tube.
4. Cut 102 mm (4 in.) off the terminal section.
5. Remove the cardboard support rings.
6. Re-assemble the flue ducts, aligning the seams.

16 JOINING THE DUCT ASSEMBLY

Wall thicknesses of 114mm (4.5 in.) to 206 (8.1 in.)

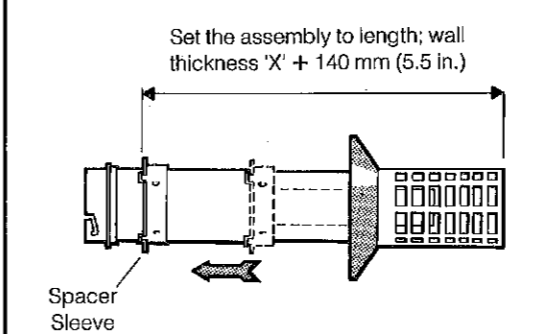

1. Using the sliding collar as a template at the duct join mark the position of the 3 fixing screws.

NOTE: If the duct join is too close to the rubber weather seal to permit access for drilling, then mark the hole positions at the mid-point of the duct.

2. Slide the collar back to the boiler end of the duct and, again, mark the position of the 3 fixing screws.

18 FITTING THE FLUE ASSEMBLY- From INSIDE the building.

1. Push the assembly through the wall sleeve until the weather seal is free. Ensure that the assembly is not pushed completely through.

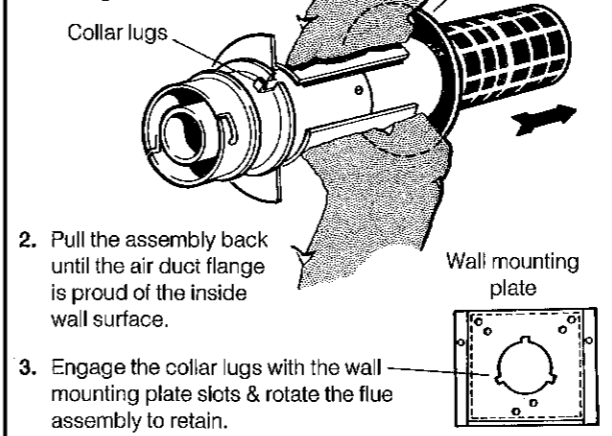

2. Pull the assembly back until the air duct flange is proud of the inside wall surface.

3. Engage the collar lugs with the wall mounting plate slots & rotate the flue assembly to retain.

20 FITTING THE FLUE ASSEMBLY- From OUTSIDE the building.

1. Fit the wall mounting plate (refer to Frame 19) but DO NOT drive the fixing screws fully home until the duct assembly is engaged. See note 2.

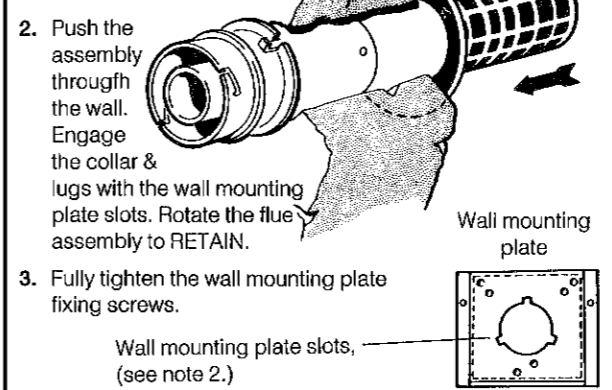

2. Push the assembly through the wall. Engage the collar & lugs with the wall mounting plate slots. Rotate the flue assembly to RETAIN.

3. Fully tighten the wall mounting plate fixing screws.

Proceed now to steps 3 & 4 of Frame 19.

17 SETTING THE DUCT ASSEMBLY

Wall thicknesses from 206mm (8.1 in.) to 396 (15.6 in.)

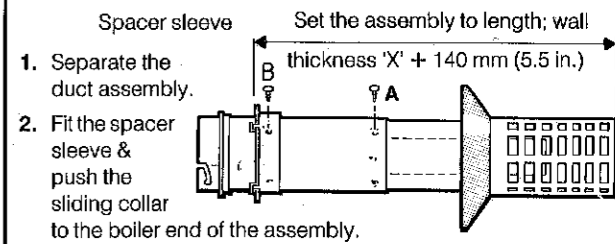

1. Separate the duct assembly.
2. Fit the spacer sleeve & push the sliding collar to the boiler end of the assembly.

3. Using the sliding collar as a template at the duct join mark the positions of the 3 air duct joining screws (A). **Note:** If the duct join is too close to the weather seal to permit access for drilling, mark the hole positions at the mid-point of the duct.

4. Slide the collar to boiler end of the duct (fully against spacer sleeve) & mark the positions of the 3 collar fixing screws, (B).
5. Drill the 6 fixing holes using the 3.2 mm drill provided & insert the self tapping screws- fixing the collar in position & locking the duct assembly. Seal the air duct join with the adhesive tape provided. DO NOT DRILL THE INNER AIR DUCT.

For wall thicknesses more than 396 mm; refer Frames 39 to 43

19 WALL MOUNTING PLATE

Flue is shown locked in position

1. Fix the mounting plate to the wall with the 8 mm x 50 mm coach screws, (do not tighten if installing from outside).
2. Check with a spirit level that the plate is vertical
3. Align the holes in the sliding collar flange with the 2 cut-outs in the wall plate. Insert 2 of the self tappers provided to lock the assembly.

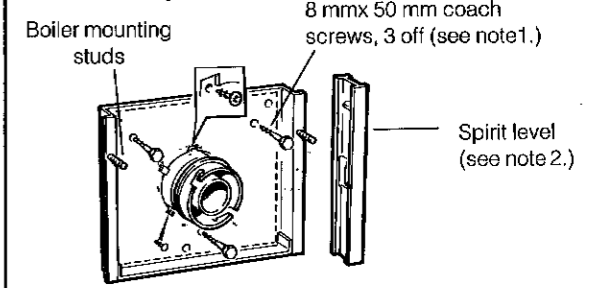

4. If applicable, fit the pump support bracket.

21 TERMINAL WALL PLATE- For flue assemblies fitted from OUTSIDE the building.

1. Position the terminal wall plate over the terminal as shown, mark the four fixing holes and remove the plate.
2. Drill four fixing holes with an 8 mm (5/16 in.) masonry drill.

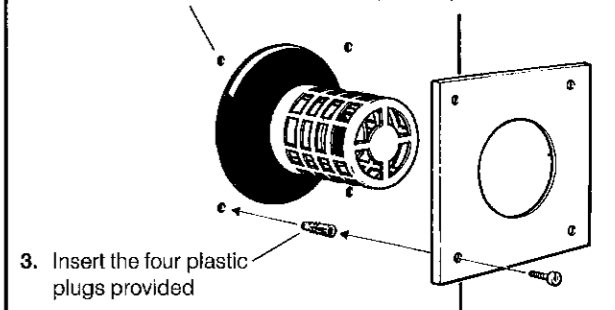

3. Insert the four plastic plugs provided

4. Secure the plate with four of the No. 10 x 2 screws provided.

NOTE: If the terminal is less than 2 m (6.6 ft) above ground level an approved terminal guard MUST be fitted- refer page 3.

22 MOUNTING THE BOILER

Securing screws & washers
Flue outlet elbow

1. Remove the two screws and washers shown. Lift off the flue outlet elbow, taking care not to damage the sealing gasket, which is adhered in position.

2. **NOTE:** Have ready to hand the sealing plates and wing nuts provided in the hardware pack.

Wall mounting plate
Air duct spigot

VIEW INSIDE BOILER AIR BOX

The boiler mounting studs fit into slots in the back panel & the air duct spigot enters the flue outlet hole in the back panel.

3. Lift the boiler onto the wall mounting plate- as shown. Ensure that the support bracket on the back of the boiler rests on the bottom return of the wall bracket.

4. Fit a sealing plate over each stud and secure with a wing nut.
NOTE: Before fully tightening the wing nuts check the boiler alignment using a spirit level and adjust as necessary with the jacking screw. Refer to Frame 3

5. Adjust the jacking screw until the hole in the wall lines up with the hole in the jacking screw plate. Locate a No. 10 x 2 screw in the boiler lower fixing hole & secure to the wall.

6. Make all water connections and check for water soundness. If a Pump Kit is fitted then refer to the instructions supplied.

7. Fit the circular flue sealing discs and inner plates. Secure with the two M5 nuts, provided.

8. Fit the side concealment panels (both left hand & right hand) with the two M5 nuts provided. Fit the circular flue sealing discs & inner plates, securing with the the two M6 nuts provided.

23 SEALING THE BOILER & FLUE

1. Stretch the rubber gasket over the air duct spigot.

2. Fit the collar as shown and rotate it to lock into the slots.

Locking slots
Locking handle

3. Fold the locking handle, as shown.

4. Slide the flue outlet elbow into the terminal flue pipe and refit the elbow in reverse order, taking care not to damage the sealing gasket- refer to Frame 22.

5. Refit the fan plate assembly in reverse order- refer to frame 2

Appliances fitted with REAR OUTLET flues:
PROCEED TO FRAME 44

24 FLUE ASSEMBLY- Exploded view

Notes:

1. An optional duct extension kit required for lengths of dimension 'Y' (wall thickness plus boiler/ wall spacing) greater than 406 mm (16 in.)- refer to frames 40 & 41.
2. An optional wall sleeve kit is required for installation from inside the building (pack 'E').
3. When cutting the ducts, always use the cardboard support rings provided.

6. Collar fixing screws, 3 off
7. Terminal fixing screws, 3off
8. Terminal assembly
9. Terminal mounting plate
10. Sliding collar
11. Flue blanking plate
12. Flue outlet elbow
13. Locking collar

Legend

1. Flue blanking plate
2. Wall mounting plate
3. Air duct gasket
4. Flue pipe connector
5. Duct assembly

25 WALL MOUNTING TEMPLATE

1. Separate the templates.
2. Tape both templates into the selected position locating template 'B' via an extended centre line as shown.
3. Ensure squareness by hanging a plumbline as illustrated.
4. Mark onto the wall the 3 mounting plate screw positions (choose 1 from each group of 2) & the lower fixing screw position also pump kit bracket screws- if applicable.
5. Mark on the wall the 4 terminal mounting plate screw positions.
6. Mark on the wall the position of the flue duct.
Note: Mark the centre of the hole as well as the circumference.
7. Remove both templates from the wall.

26 PREPARING THE WALL

IMPORTANT: Ensure that, during the cutting operation, masonry falling outside of the building does not cause damage or personal injury. **Note:** Check all hole positions before drilling.

SECTION THROUGH WALL

1. Cut the flue hole preferably using a 5 in. core boring tool. Ensure that the hole is square to the wall.
2. Measure wall thickness 'X' and calculate dimension 'Y', ie. 'boiler spacing' plus 'X', refer to frame 10.
3. Drill the 3 wall plate holes with a 10mm (3/8 in.) bit. Drill the remaining 5 holes with an 8mm (5/16 in.) masonry bit, (if applicable drill the pump bracket holes).
4. Insert, into the drilled holes, the 8 plastic plugs provided.
5. Locate 2 No. 10 x 2 screws in the terminal mounting plate top fixing holes & screw to within 6 mm (1/4 in.) of wall surface.

27 WALL SLEEVE- For installation from INSIDE the building only

1. Cut the sleeve to length ('X' - 10 mm).
2. Slide into the wall opening as shown.
3. Make good at the inside end & at the outside end by reaching through the sleeve.

Wall sleeve

INSIDE WALL SURFACE

Wall thickness 'X'

Note: Maximum wall thickness- 620 mm (24.4 in.).

28 CUTTING THE DUCT ASSEMBLY

For flue lengths, dimension 'Y', of 114 mm (4.5 in.) to 216 mm (8.5 in.) ONLY, [Flue Pack 'B'].

1. Separate the duct assembly
2. Push the sliding collar to the end of the duct & measure off dimension 'Y'
3. Cut to length 'Y' using cardboard duct support rings.
Note: Cut inner flue tube 6 mm (1/4 in.) longer than air tube.
4. Cut 102 mm (4 in.) off the terminal section.
5. Remove the cardboard support rings.
6. Re-assemble the flue ducts, aligning the seams.

Sliding collar

Terminal section

INSTALLATION: SIDE FLUE

29 JOINING THE DUCT ASSEMBLY

Wall thicknesses of 114 mm (4.5 in.) to 216 mm (8.5 in.)

1. Set the assembly to length; dimension 'Y' plus 140 mm (5.5 in.)

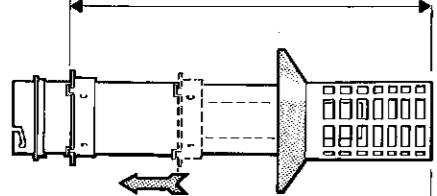

Dimension 'X' plus 140 mm (5.5 in.)

2. Using the sliding collar as a template at the duct join, mark the position of the 3 fixing screws. **Note:** If the duct join is too close to the rubber weather seal to permit access for drilling, then mark the hole position at the mid point of the duct.
3. Set the collar to the required position, i.e. Dimension 'X' plus 140 mm (5.5 in.). Mark the positions of the 3 fixing screws. Proceed now to step 5. of Frame 30.

FLUE FITTING- WALL MOUNTING PLATE

30 SETTING THE DUCT ASSEMBLY

For flue lengths, dimension 'Y', of 216mm (8.5 in.) to 406mm (16 in.).

1. Separate the duct assembly.
2. Push the sliding collar to the end of the duct.
3. Set the assembly to length; dimension 'Y' plus 140 mm (5.5 in.).
4. Using the sliding collar as a template at the join, mark the position of the 3 air duct joining screws (A). **Note:** If the duct join is too close to the weather seal to permit access for drilling then mark the hole positions at the mid point of the duct. Also if the air duct joining screws restrict the sliding collar then use the collar fixing screws (B) to secure the whole assembly.

to the weather seal to permit access for drilling then mark the hole positions at the mid point of the duct. Also if the air duct joining screws restrict the sliding collar then use the collar fixing screws (B) to secure the whole assembly.

5. Set the collar to required position, i.e. Dim. 'X' plus 150 mm (6 in.) & mark the positions of the 3 collar fixing screws (B). Drill the 6 fixing holes using the 3.2 mm drill provided. Insert the self tapping screws to fix the collar in position and lock the duct assembly. **DO NOT DRILL THE INNER FLUE DUCT.** For flue lengths more than 406 mm- refer to Frames 40- 43

31 FITTING THE FLUE ASSEMBLY- From INSIDE the building

1. Push the assembly through the wall sleeve until the weather seal is free. Ensure that the assembly is not pushed completely through.

2. Pull the assembly back until the air duct flange is proud of the inside wall surface.

4. Engage the collar lugs with the terminal plate slots & rotate flue assembly to lock.

5. Engage the plate on the two fixing screws.

Terminal plate slots (see note 4.)

Proceed now to step 3. of Frame 33.

32 FITTING THE FLUE ASSEMBLY- From OUTSIDE the building

1. Fit the terminal mounting plate- refer to steps 1-5 of Frame 31 but **DO NOT** drive the fixing screws fully home until the duct assembly is engaged.

2. Push the assembly through the wall and engage the collar lugs with the terminal mounting plate slots. Rotate the flue assembly to lock.

3. Align the holes in the sliding collar flange with two of the cut-outs in the wall plate. Insert 2 of the self tapping screws provided to retain the flue assembly.

Terminal plate slots (see note 2.)

Proceed to Frame 34.

33 TERMINAL MOUNTING PLATE

1. Stick the sealing tape provided to the reverse side of the plate.
2. Engage the plate on the top two fixing screws

3. Locate two No. 10 x 2 screws in the bottom fixing holes & drive home all 4 screws. **Note:** Flue is shown locked into position

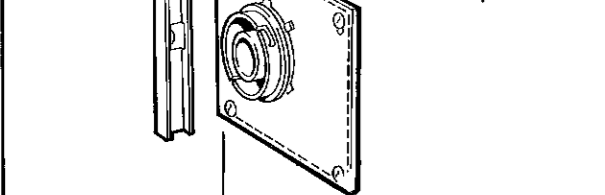

4. Check with a spirit level that the plate is vertical.
5. Make good between the plate & the corner of the wall.

6. Align the holes in the sliding collar flange with two of the cut-outs in the wall plate. Insert two of the self tapping screws, provided, to lock the flue assembly.

34 WALL MOUNTING PLATE

1. Fix the wall mounting plate to the wall with the three 8 mm x 50 mm coach screws.

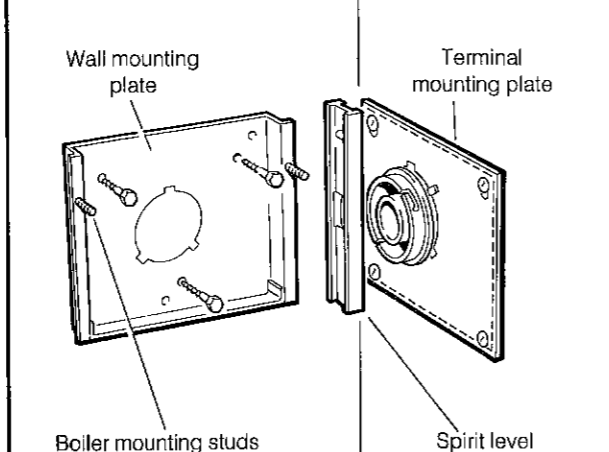

2. Check with a spirit level that the plate is vertical.

INSTALLATION: SIDE FLUE

35 TERMINAL WALL PLATE- For flue assemblies fitted from OUTSIDE the building ONLY

1. Position the terminal wall plate over the terminal as shown, mark the four fixing holes and remove the plate.
2. Drill four fixing holes with an 8 mm (5/16 in.) masonry drill.

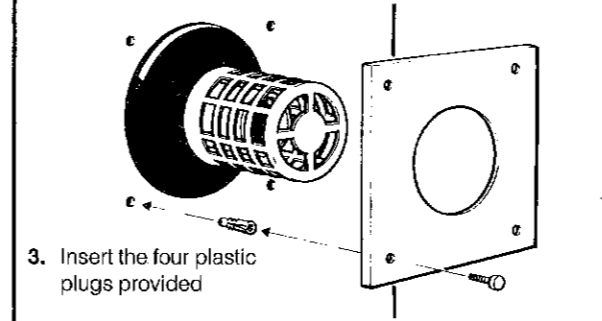

3. Insert the four plastic plugs provided
4. Secure the plate with four of the No. 10 x 2 screws provided.

Note: If the terminal is less than 2 m (6.6 ft) above ground level an approved terminal guard **MUST** be fitted- refer page 3.

4. Lift the boiler onto the wall mounting plate as shown. Ensure that the support bracket, on the back of the boiler, rests on the bottom return of the wall bracket. Slide the boiler side-ways into it's intended position. Centralize the studs in the slots & engage the end of the air duct in the hole in the side panel.

5. Fit sealing plates over each stud and secure with wing nuts. **Note:** Before fully tightening the wing nuts check the boiler alignment using a spirit level and adjust as necessary with the jacking screw, refer to Frame 7.

6. Adjust jacking screw until the hole in the wall lines up with the hole in the jacking screw plate. Locate a No. 10 x 2 screw, in the boiler lower fixing hole and secure to the wall.

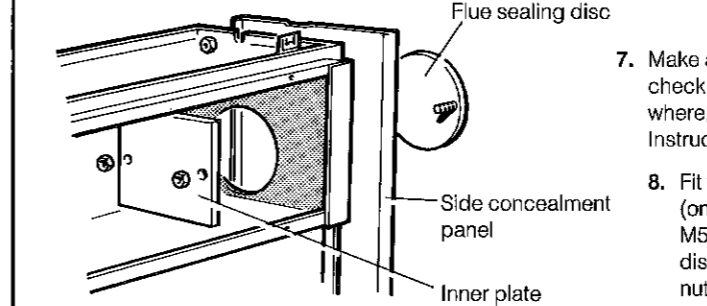

37 SEALING THE BOILER & FLUE

1. Stretch the rubber gasket over the air duct spigot.
2. Fit the collar as shown & rotate it to lock into the slots.

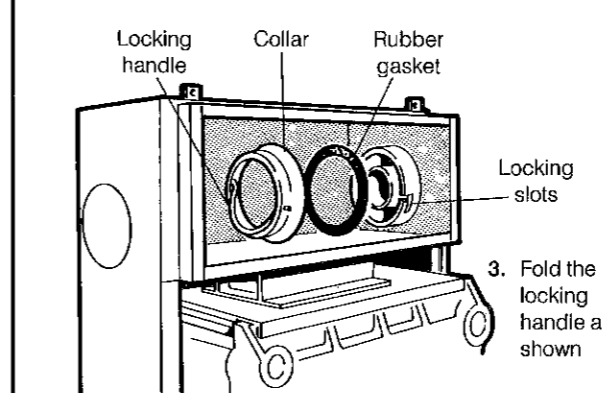

3. Fold the locking handle as shown
4. Slide the flue outlet elbow into the terminal flue pipe & refit the elbow in reverse order. Take care not to damage the sealing gasket, refer to Frame 38

5. Refit the fan plate assembly in reverse order, refer to frame 2

BOILER MOUNTING- SEALING THE FLUE

36 MOUNTING THE BOILER

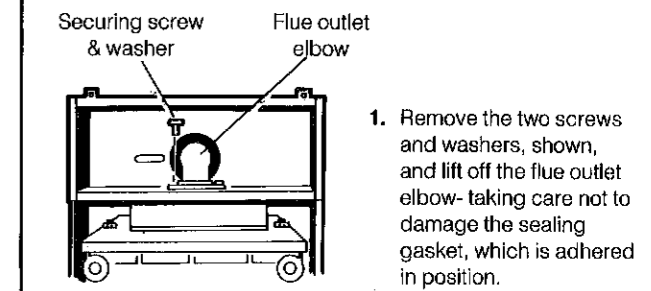

VIEW INSIDE BOILER AIR BOX

1. Remove the two screws and washers, shown, and lift off the flue outlet elbow- taking care not to damage the sealing gasket, which is adhered in position.
2. Fit a pair of blanking plates & discs to the rear flue outlet hole.
3. Fit the side concealment panel to the flue side only and secure with two M5 nuts. **Note:** Have ready, to hand, the sealing plates (previously removed) and wing nuts provided in the hardware pack.

The boiler mounting studs fit into slots in the back panel. The air duct spigot enters the flue outlet hole in the side panel.

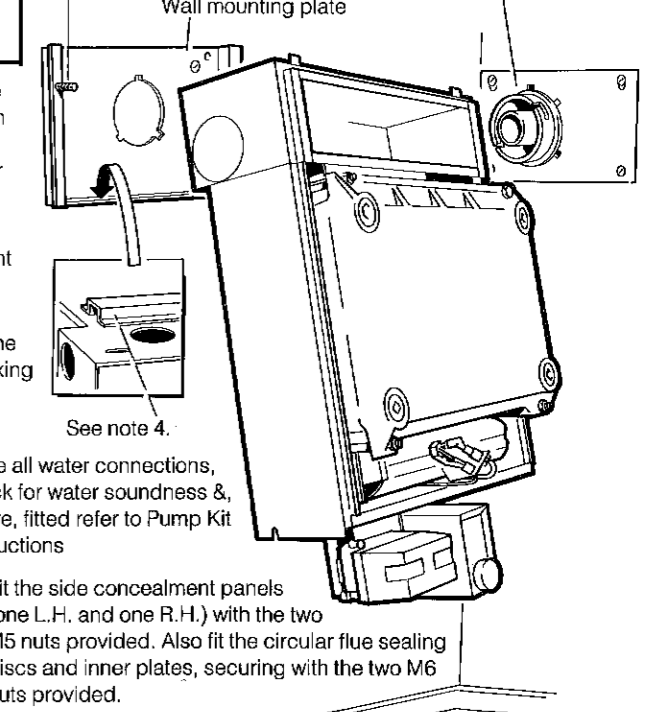

38 SEALING THE BOILER & FLUE

DIAGRAM TO SHOW THE FLUE OUTLET ARRANGEMENT.

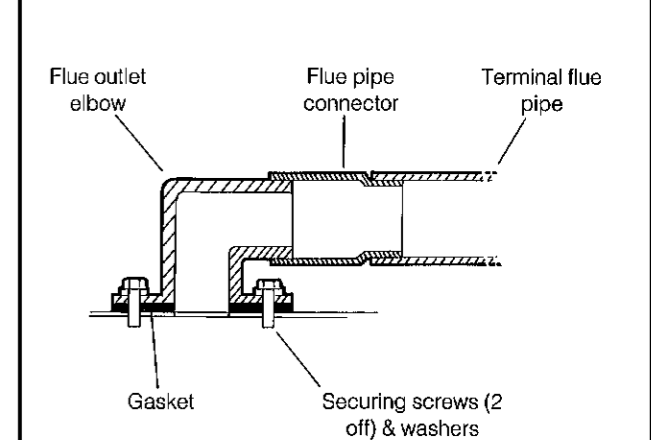

PROCEED TO FRAME 44

INSTALLATION

FLUE EXTENSION DUCTS

39 GENERAL ARRANGEMENT

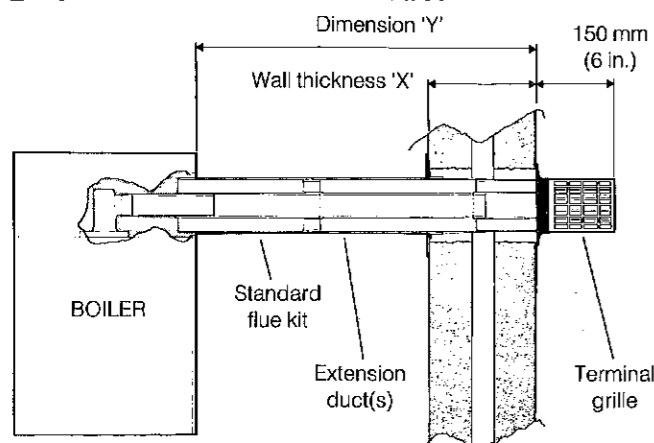

1. A MAXIMUM of two kits may be used together.
2. Cut extension ducts at the plain ends only.
3. Ensure that there is, at least, a 25mm (1 in.) overlap at each end of the joint.
4. For flue lengths of less than 216 mm (18 in.) ensure that the sliding collar (frames 42 & 43) is positioned on an air duct.

Flue dimension Rear 'X' & Side 'Y'	Std. Flue Pack 'B'	Pack 'B1'	Extension Pack 'D'
<i>SIDE FLUE (Dimn. 'Y'). See Frame 28 for cutting details</i>			
Lengths up to 406 mm (16 in.)	1 off		
406 mm (16 in.) → 610 mm (24 in.)	1 off	1 off	
610 mm (24 in.) → 1257 mm (49.5 in.)	1 off		1 off
1257 mm (49.5 in.) → 2 m. (79 in.)	1 off		2 off
<i>REAR FLUE (Dimn. 'X'). See Frame 15 for cutting details</i>			
114 mm (4.5 in.) → 396 mm (15.6 in.)	1 off		
396 mm (15.6 in.) → 600 mm (23.6 in.)	1 off	1 off	
600 mm (23.6 in.) → 1247 mm (49.1 in.)	1 off		1 off
1247 mm (49.1 in.) → 1990 mm (78.3 in.)	1 off		2 off

5. Extensions of greater than 1 m. (39 in.) should be supported with the bracket.
6. Tape all air duct connections.
7. Always align the seams when re-assembling the ducts.

40 PACK 'B1'

For flue lengths ('X' or 'Y') up to 610 mm (24 in.).

SEE ABOVE TABLE.

This kit contains the following;

Extension duct;
203 mm (8 in.) long, 1 off

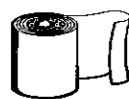
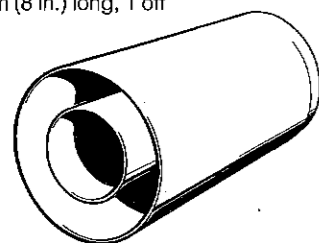

Length of adhesive tape



No. 8 x 1/4 in. self tapping screws, 3 off

41 PACK 'D'

For flue lengths ('X' or 'Y') up to 2 m. (79 in.).

Use a maximum of two kits only- SEE ABOVE TABLE.

This kit is suitable for both rear & side outlet flue configurations

This kit contains the following;

Extension duct;
850 mm (33 in.) long, 1 off

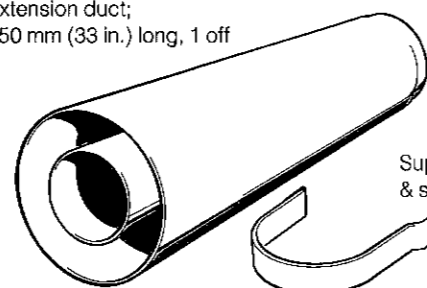

Support bracket & spacer, 1 off

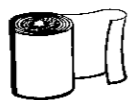

Length of adhesive tape

No. 8 x 1/4 in. self tappers, 4 off
No. 10 x 3 1/2 in. self tappers, 1 off
Wall plug, 1 off

42 FITTING

IMPORTANT: Read in conjunction with Frame 39

1. Separate the duct assembly.

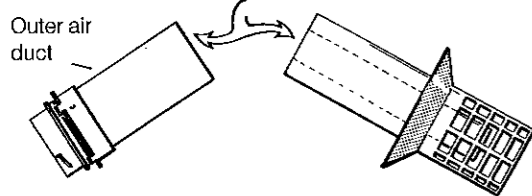

2. Insert the appropriate extension duct(s) with the plain end towards the terminal.
3. Re-assemble the terminal and the duct assemblies
4. Set the assembly to length; refer to frame 43, steps 1 & 2.

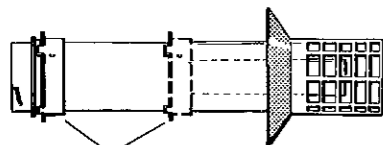

5. Using the sliding collar as a template at the joins of any ducts mark the positions of the 3 fixing screws.

43 FITTING

1. Push the collar back to the boiler end of the duct, or to it's intended position
2. Set the assembly to length, i.e. Dimension 'X' or 'Y' plus 140 mm (5.5 in.)

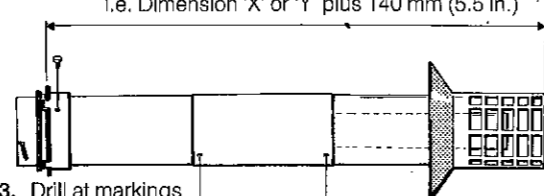

3. Drill at markings with the 3.2 mm drill provided.
4. Lock the assembly in position with the self tappers provided.
5. Drill through holes of collar into the air duct with the 3.2 mm drill and lock the sliding collar into position with 3 of the self tapping screws provided.

Note: If flue duct assembly locking screws restrict the sliding collar then use the collar locking screws to lock whole assembly.

REFER BACK TO FRAME 18; REAR FLUE OR FRAME 31; SIDE FLUE

INSTALLATION

44 GAS CONNECTION

A MINIMUM gas pressure of 20 mbar (8 in.w.g.) MUST be available at the boiler inlet.

The main gas cock is on the left hand side of the control valve & below the boiler. Connection to the gas supply MUST be from the REAR of the boiler and from below.

FRONT VIEW

SIDE VIEW

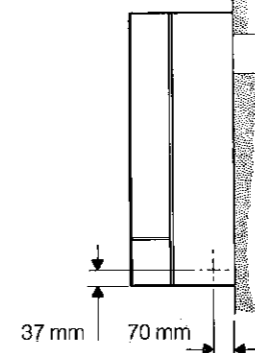
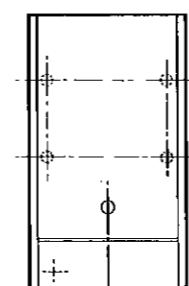

Also refer to the section headed Gas Supply on page 3.

SERVICE CONNECTIONS- WIRING DIAGRAMS

45 ELECTRICAL CONNECTIONS

WARNING: The appliance MUST be efficiently earthed.

A mains supply of 240 V ~ 50 Hz, Single Phase, is required.

All external controls & wiring MUST be suitable for mains voltage. Wiring should be in 3-core PVC insulating cable, NOT LESS than 24/0.2 mm (0.75 mm²) to BS.6500 Table 16.

All wiring external to the boiler, including the room thermostat etc., MUST be in accordance with the latest I.E.E. Wiring Regulations and Local Regulations which apply.

The supply connection may be made via a removable plug to an unswitched shuttered socket outlet and should such a plug be used for connection to the mains, it MUST be of 3-pin type, wired as shown, fused at 3 A and complying with the requirements of BS.1363.

Alternatively a fused, double pole switch, having at least a 3 mm (1/8 in) contact separation in both poles and serving only the boiler may be used.

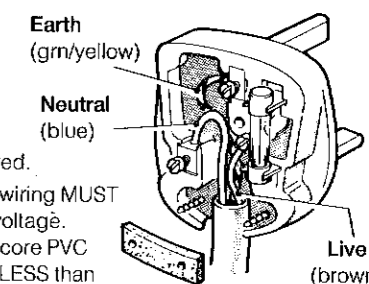

46 ELECTRICAL CONNECTIONS & FUNCTIONAL FLOW WIRING DIAGRAM

Note: If the optional programmer kit is to be fitted, refer to the instructions provided with the kit, ignore this section and go to Frame 47. The internal wiring of the control box is shown opposite and also in Frame 48.

A wiring diagram is also contained in the Lighting Instructions (inside the control pod door).

A plug & socket connector is provided on the boiler control box for the mains supply

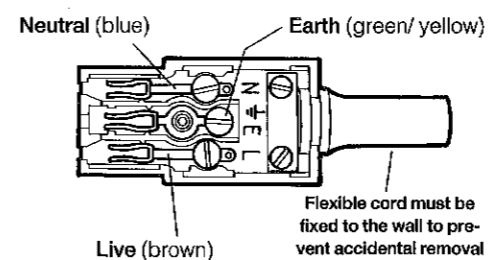

Legend

br brown r red y yellow
b blue pk pink v violet
w white or orange

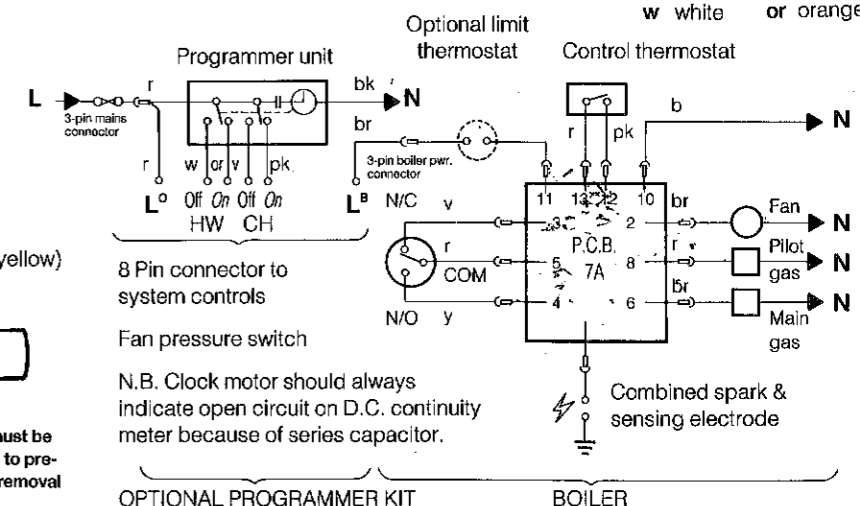

47 EXTERNAL CONTROLS

The wiring diagrams illustrated in Frames 48 to 52 cover the systems most likely to be fitted to this appliance.

For wiring external controls to the Ideal W 2000 F boiler, reference should be made to the system wiring diagrams supplied by the relevant Manufacturer, in conjunction with the wiring diagrams shown in Frames 46 and 48.

Difficulty in wiring should not arise, providing the following directions are observed.

1. Controls that switch the system ON and OFF e.g. a timer switch, MUST be wired in series, in the live mains lead to the boiler.
2. Controls that over-ride an ON/ OFF control, e.g. a frost thermostat, MUST be wired into the mains lead, in parallel with the control(s) to be over-riden - refer to Frame 52.
3. Controls that switch the circulating pump only ON and OFF e.g. a room thermostat, MUST be wired in series, with the pump in the live pump lead.
4. If a proprietary system is used, follow the instructions supplied by the Manufacturers.
5. SYSTEM DESIGNS FEATURING CONTROLS OR WIRING ARRANGEMENTS, WHICH ALLOW THE BOILER TO FIRE

WHEN THERE IS NO PUMPED OR GRAVITY CIRCULATION TAKING PLACE, SHOULD NOT BE FITTED.

Advice on required modifications to the wiring may be obtained from the component Manufacturers.

NOTES:

1. Connections between a frost thermostat and the time control should be made without disturbing other wiring.
2. A frost thermostat should be sited in a cool place in the house, but where it can sense heat from the system.

Wire the mains connector, supplied strapped to the control box, as follows:

Live (brown) to L
Neutral (blue) to N
Earth (green/yellow) to ⚡

The connector may now be plugged into the control box
Note: When the optional programmer kit is fitted, the incoming mains lead should be connected to the programmer mains plug. The boiler control box three-pin plug should be wired in accordance with the system diagrams shown in Frames 48 - 52 and programmer installation instructions.

48 PICTORIAL WIRING

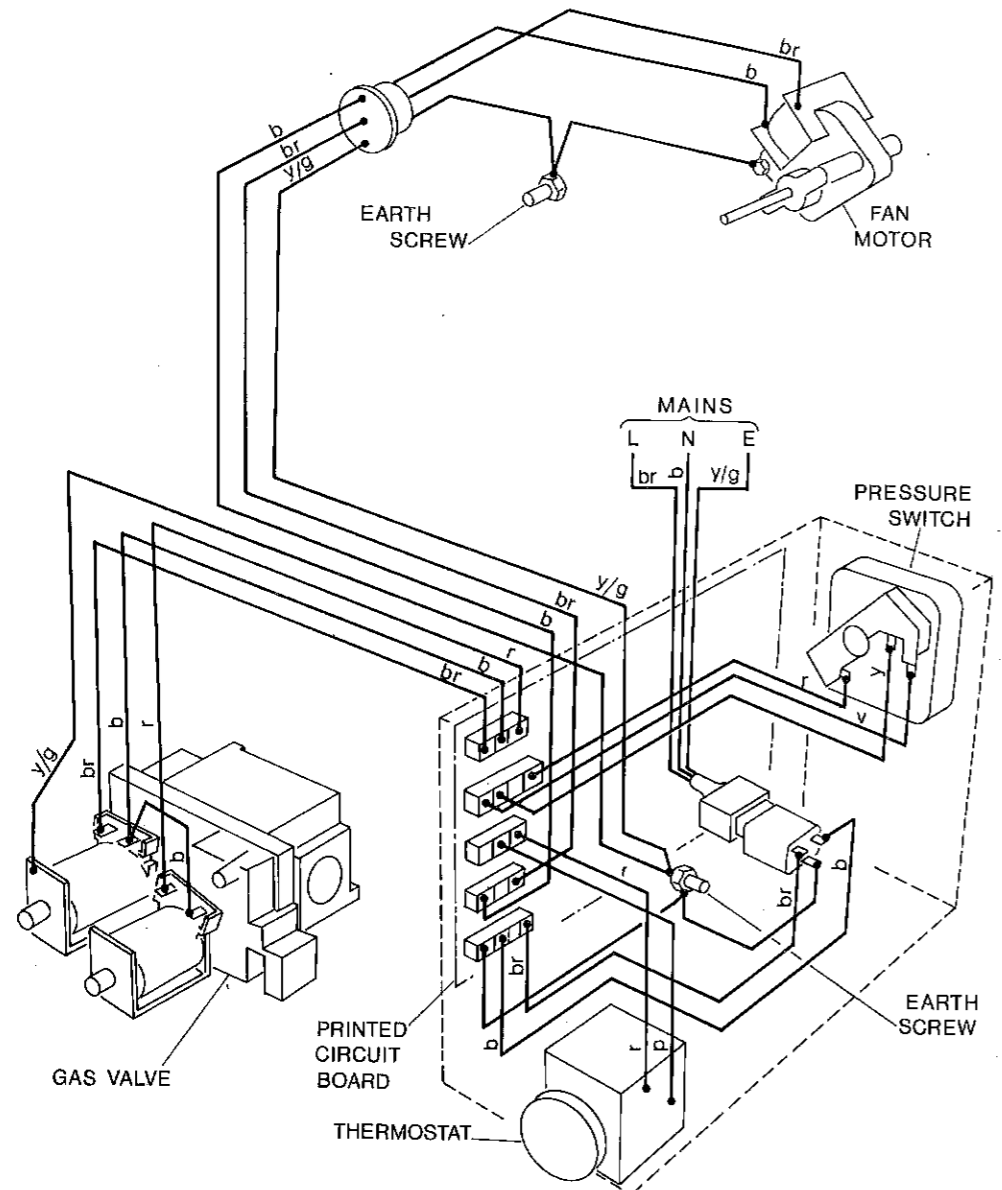

- Legend:**
- br brown
 - b blue
 - r red
 - g/y green/yellow
 - v violet
 - p pink
 - y yellow

50 TWO SPRING CLOSED VALVES

Pumped only

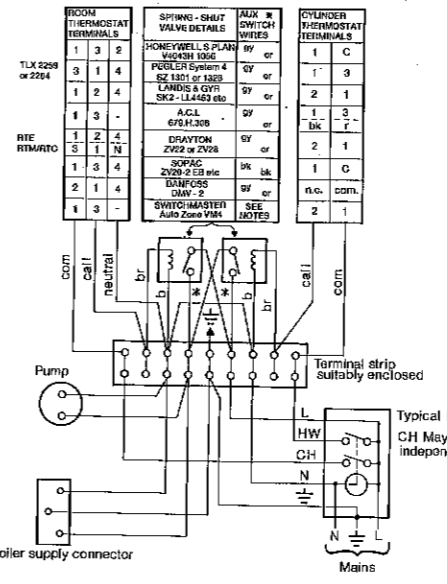

- Notes:**
- Some earth wires are omitted for clarity. Ensure proper earth continuity when wiring.
 - Numbering of terminals on thermostats is specific to the Manufacturer.
 - This is a fully controlled system - set the boiler thermostat to maximum.
 - Switchmaster valve has grey and orange leads, but the GREY wire must be the one connected to the incoming supply.

- Legend**
- b blue
 - bl black
 - br brown
 - gy grey
 - or orange
 - r red
 - w white

51 HONEYWELL 'C' PLAN

Pumped only

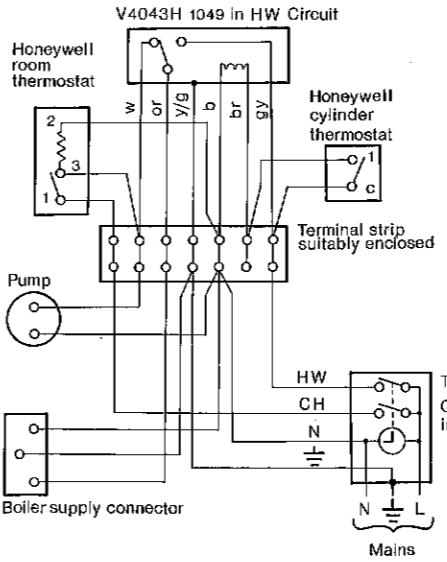

- Notes:**
- Some earth wires are omitted for clarity. Ensure proper earth continuity when wiring.
 - Numbering of terminals on thermostats is specific to the Manufacturer.

- Legend**
- b blue
 - bl black
 - br brown
 - gy grey
 - g green
 - or orange
 - r red
 - y yellow
 - w white

49 MID POSITION VALVE

Pumped only

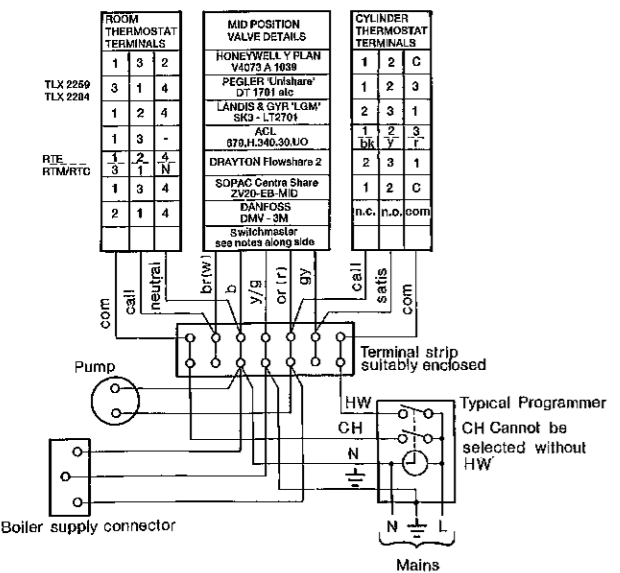

- Notes:**
- Some earth wires are omitted for clarity. Ensure proper earth continuity when wiring.
 - Numbering of terminals on thermostats is specific to the Manufacturer.
 - This is a fully controlled system - set the boiler thermostat to maximum.
 - Switchmaster 'Midi' is similar in operation, but the wiring differs slightly; see Manufacturer's literature.

- Legend**
- b blue
 - bl black
 - br brown
 - gy grey
 - g green
 - or orange
 - r red
 - y yellow
 - w white

52 FROST PROTECTION

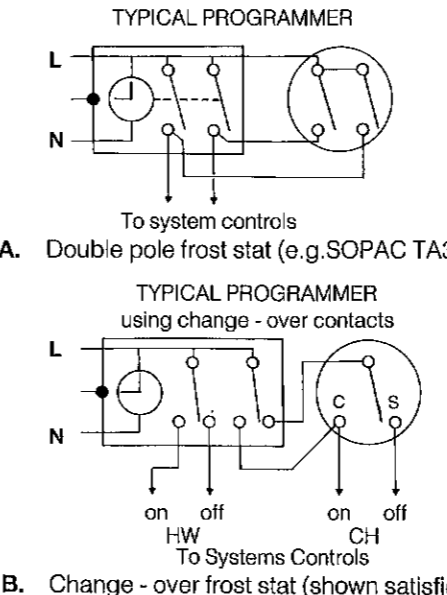

Central heating systems fitted wholly inside the house do not normally require frost protection, since the house act as an overnight 'Storage Heater', and can generally be left as least 24 hours without fear of frost damage.

If, however, parts of the pipework run outside the house, or if it is desired to leave the boiler off for more than a day or so, then a frost-start should be wired into the system. This is normally done at the programmer, in which case the programme SELECTOR switches are set to 'OFF' and all other controls MUST be left in the running position. The frost stat should be sited in a cold place, but where it can sense heat from the system. Wiring should be basically as shown, with a minimal disturbance to other wiring to the programmer. Designation of the terminals will vary, but the programmer and thermostat manufacturer's leaflets will give full details.

Diagram B shows a 'Change Over' frost 'stat', which will cover most all systems which do not use the 'OFF' terminals of the programmer.

Diagram A shows a 'Change Over' frost stat, which will cover most systems which do use CH OFF. If however, on such a system, the HW pipework is in an isolated part of the house, a second frost stat may be used to protect it also. If in doubt, ask your installer for advice.

53 COMMISSIONING & TESTING

(a) Electrical Installation

1. Checks to ensure electrical safety should be carried out by a competent person.
2. ALWAYS carry out the preliminary electrical system checks as detailed in the instructions for the British Gas Multimeter, or similar test meter.
3. Refit the control box cover.

(b) Gas Installation

1. The whole of the gas installation, including the meter, must be inspected and tested for soundness, and purged in accordance with the recommendations of CP.331.3.
2. The purging of air from the gas installation may be expedited by loosening the union on the gas service cock and purging until gas is smelled.
3. Retighten the union and check for gas soundness.

WARNING: Whilst effecting the required gas soundness test and purging air from the gas installation, open all windows and doors, extinguish naked lights. DO NOT SMOKE.

55 FITTING THE CASING

1. Lift the boiler casing up to the boiler assembly and secure with the 4 captive screws.

The casing must seat correctly and compress the sealing strip to make an airtight joint.

Visually check the side seals but if side clearances are limited then check that the top and bottom edges of the casing are correctly located.

2. Fit controls pod bottom panel using the four M4 x 10 screws in the hardware pack, after first completing the gas soundness checks detailed in Frame 56.

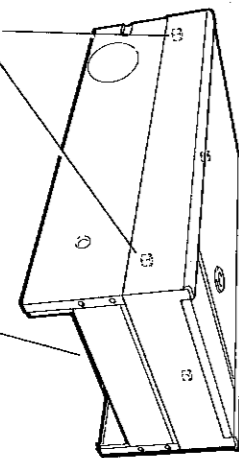

54 INITIAL LIGHTING

Continued in Frame 56

1. Check that all the drain cocks are closed, and any valves in the flow and return are open.
2. Check that the gas service cock (C) is ON and the boiler thermostat knob (G) is OFF. See Frame 56 For Details.
3. Remove the screw in the burner pressure test nipple (F) and connect a gas pressure gauge via a flexible tube.
4. Undo the gas valve cover retaining screw and remove cover.
5. Ensure that the electrical supply is isolated.
6. Remove the control box cover.

7. Remove push on connector (Marked '1' & '2') from the printed circuit board, and replace with the single loose orange wire connector labelled for pilot gas soundness check only.

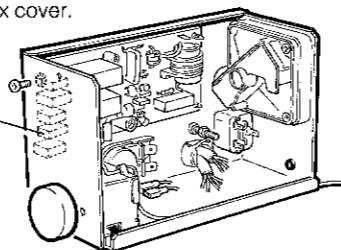

VIEW OF CONTROL BOX WITH COVER REMOVED

8. Refit control box cover.
9. Pull RED lead connector off gas valve pilot solenoid and replace with the loose orange lead connector.
10. Switch the electricity supply ON and check that all external controls are calling for heat.
11. Set the boiler thermostat knob to position 6. The pilot solenoid valve should open (the main burner will not operate).
12. Test the pilot supply connection at the pilot burner for gas soundness and also the inlet flange at the gas control valve using leak detection fluid.
13. Set the burner thermostat knob (G) to OFF and isolate the electricity supply.
14. Remove the control box cover. Remove the connector at positions '1' & '2' on the printed circuit board and replace the original connector. Refit the control box cover.
15. Remove the orange lead connector at the gas valve and replace it with the original red lead connector.
16. If the boiler output is to be set to minimum or mid, affix the appropriate indicator label supplied in the hardware pack to the data plate, located on the lower R.H. side of the back panel.
17. Fit the boiler casing, refer to Frame 55.

56 INITIAL LIGHTING- Continued

To Light the Boiler

1. Switch the electricity supply ON and check that all external controls are calling for heat.
2. Set boiler thermostat knob (G) to position 6 & the fan will start. After the fan has run for a few seconds the pilot solenoid will open & the intermittent spark commence, continuing until the pilot is established. Check the appearance of the pilot flame -refer to Frame 4 of routine servicing. **Note:** The pilot flame is factory set & no adjustment should be necessary. However if the pilot flame is incorrect refer to Frame 8 of routine servicing.
3. Once the pilot is established the main gas will come on. Check that the main burner cross-lights smoothly. If this sequence does not occur then refer to the 'Fault Finding' section.
4. Test for gas soundness around the remaining boiler gas components using leak detection fluid. Particularly check gas valve flanges.
5. Operate boiler for 10 minutes to stabilise burner temperature.
6. The boiler is pre-set at the factory to its highest nominal rating, but it can be range rated to suit the system design requirements. Refer to Table 2 on page 2. Turn pressure adjusting screw (E) clockwise to decrease the pressure. Replace the valve cover after adjustments are made

BOILER CONTROLS

Legend

- A Sight Glass
- B Pilot pressure adjuster
- C Gas service cock
- D Inlet pressure test nipple
- E Main burner pressure adjuster
- F Burner pressure test nipple
- G Thermostat Knob

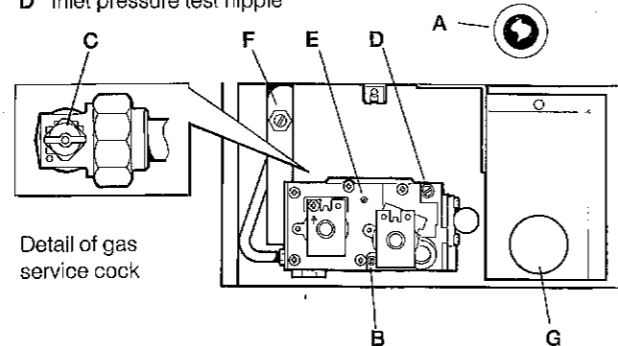

7. Set the boiler thermostat knob to OFF.
8. Remove the pressure gauge & tube. Replace the sealing screw in the pressure test nipple.
9. Turn ON & check gas soundness at the sealing of the screw.

57 GENERAL CHECKS

Make the following checks for the correct operation.

1. Turn the boiler thermostat knob from position '6' to OFF & to position '6' again. Check that the main burner lights & extinguishes in response.
2. Check the correct operation of the programmer, if fitted. All other system controls should also be proved. Operate each control separately and check that the main burner responds.
3. Check that the casing is sealed correctly and compressing the sealing strip all around the casing.
4. **Water Circulation System**
 - (a) With the system HOT, examine all water connections for soundness.
 - (b) With the system still hot; turn off the gas, water and electricity supplies to the boiler and drain down in order to complete the flushing process.
 - (c) Re-fill and vent the system, clear all air locks and again check for water soundness.
 - (d) Balance the system.

Finally, set the controls to the Users requirements.

Notes:

1. If an optional Programmer Kit is fitted then refer to the both the Programmer Kit Installation Instructions and the Programmer User's Instructions.
2. The temperatures quoted below are approximate and vary between installations:

Knob setting	Flow Temperature	
	°C	°F
1	54	130
2	60	140
3	66	150
4	71	160
5	77	170
6	82	180

WARNING: The boiler MUST NOT be operated with the casing removed.

58 HANDING OVER

After completing the installation and commissioning of the system, the installer should hand over to the Householder by the following actions.

1. Hand the User's Instructions to the Householder and explain his or her responsibilities under the Gas Safety (Installation and Use) Regulations 1984.
2. Draw attention to the Lighting Instruction Label affixed to the inside of the control casing door.
3. Explain and demonstrate the lighting and shutting down procedures.
4. The operation of the boiler and the use and adjustments of ALL system controls should be fully explained to the Householder, to ensure the greatest possible fuel economy consistent with the household requirements of both heating and hot water consumption.

Advise the User of the precautions necessary to prevent damage to the system, and to the building, in the event of the system remaining inoperative during frosty conditions.

5. Explain the function and the use of the boiler thermostat & external controls.
6. Explain the function of the boiler over-heat thermostat (only fitted for sealed system use) and emphasise that if cut out persists, the boiler should be turned off and the local Heating Installer consulted.
7. Explain and demonstrate the function of time and temperature controls, radiator valves, etc, for the the economic use of the system.
8. If an optional Programmer Kit is fitted, then draw attention to the Programmer Kit User's Instructions and hand them to the Householder.
9. Stress the importance of regular servicing by the Local Gas Region or by a qualified Heating Engineer and that a comprehensive service should be carried out AT LEAST ONCE A YEAR.

SERVICING

1 SCHEDULE

The following should be carried out at periods not exceeding one year.

- Light boiler & carry out a pre-service check, noting any operational faults.
- Clean the main burner.
- Clean the heat exchanger.
- Clean the main and pilot injectors.
- Check that the flue terminal is unobstructed and that the flue system, including the inner cover, is sealed correctly.
- If the appliance is installed in a compartment, check that the ventilation areas are clear.

The routine servicing procedures are covered more fully in Frames 2 to 8 & must be carried out in sequence.

WARNING: Always turn OFF the gas supply at the gas service cock and switch OFF and DISCONNECT the electricity supply to the appliance BEFORE SERVICING.

IMPORTANT: After completing any servicing or exchange of components always test for gas soundness and carry out functional checks as appropriate.

Note: In order to carry out either servicing or replacement of components then the boiler casing must be removed (Frame 2).

IMPORTANT: When work is complete the casing MUST be correctly re-fitted, ensuring that a good seal is made. The boiler MUST NOT be operated if the casing is not fitted.

3 BURNER & CONTROLS ASSEMBLY REMOVAL

- Undo the union on the gas service cock.
- Remove the control box cover by undoing the retaining screw- slide forward.

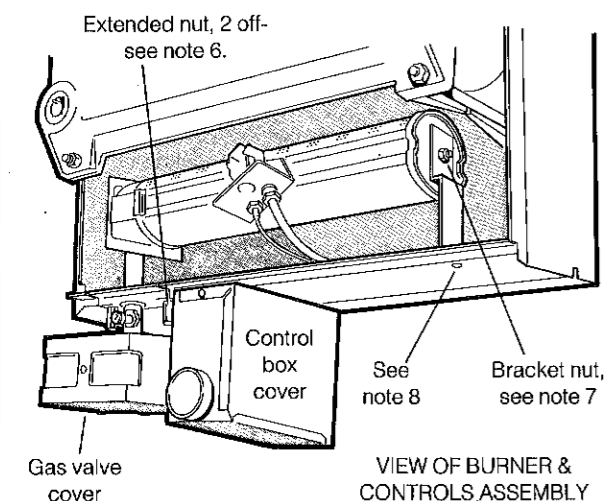

- Disconnect the ignition/detection lead at the printed circuit board and withdraw it from the box.

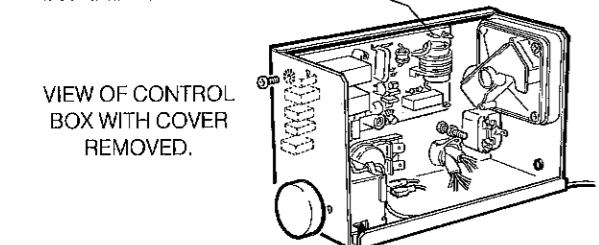

- Remove the gas valve cover by releasing the securing screw.
- Disconnect the push on electrical leads from the solenoids and unscrew the earth terminal securing screw (see 'Burner & Controls assembly', under section- Exploded Views).
- Remove the two extended nuts securing the burner manifold sealing arrangement.
- Remove the nut securing the end of the burner to the support bracket.
- Remove the screw retaining the burner support bracket to the back panel surround and remove the bracket.
- Remove the burner assembly and controls to a safe place for inspection and attention.

GENERAL- CLEANING & ADJUSTMENT

2 BOILER CASING REMOVAL

- Open the controls pod door. Unhinge and remove the door.

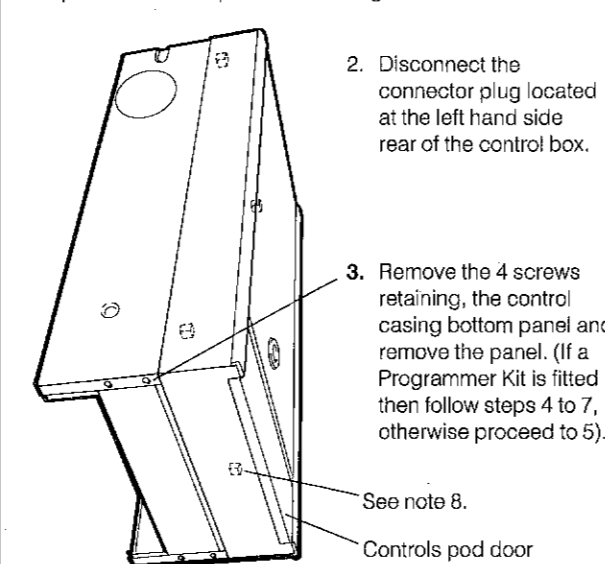

PROGRAMMER MODELS ONLY

- If a programmer kit is fitted, pull out the mains connector plug from the back of the programmer.

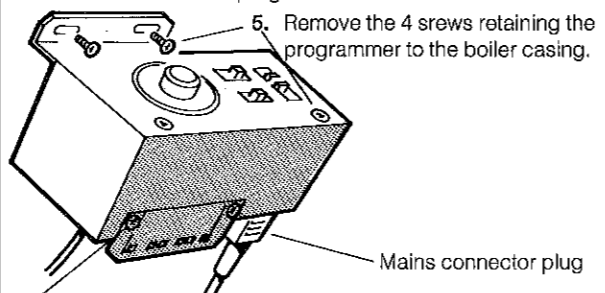

- Remove the programmer by tilting forward and withdrawing through the front of the control casing.

STANDARD & PROGRAMMER MODELS ONLY

- Release the 4 captive screws at the top & bottom of the casing. Lift the casing off the boiler & retain in a safe place.
- Isolate the gas supply at the gas service cock.

4 CLEANING BURNER ASSEMBLY

- Brush off any deposits that may have fallen onto the burner head, ensuring the flame ports are unobstructed. Remove any debris that may have collected on any components. **Note:** Brushes with metallic bristles MUST NOT be used.
- Remove the main burner, refer to Frame 15.
- Remove the main burner injector, ensuring there is no blockage or damage. Clean or renew as necessary.
- Refit the injector. Use, sparingly, an approved jointing cpd.
- Inspect the pilot burner & ignition/detector electrode. Ensure they are clean & in good condition; in particular check that,
 - The pilot injector is not blocked or damaged, refer Frame 13 for removal.
 - The pilot burner is clear and unobstructed.
 - The ignition/detection electrode is clean & undamaged.
 - The ignition detection lead is in good condition.
 - The spark gap is correct; clean or renew as necessary.
- Re-assemble the burner/ controls assembly in reverse order. **Note:** Inspect & if necessary replace the case/ manifold sealing gasket. DO NOT REFIT BURNER ASSEMBLY.

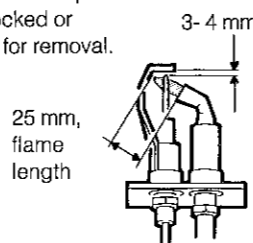

SERVICING

5 CLEANING THE FAN ASSEMBLY

- Disconnect the fan leads.
- Remove the top securing screws
- Slacken the bottom securing screws & remove the fan mounting plate assembly.
- Check that the fan impeller runs freely. Clean with a soft brush or renew as necessary, refer to Frame 18. **Note:** Always take care when handling the fan, due to the balance of the impeller.
- Check that the air inlet duct is unobstructed.
- Check the self adhesive fan plate seal for damage and replace as necessary.

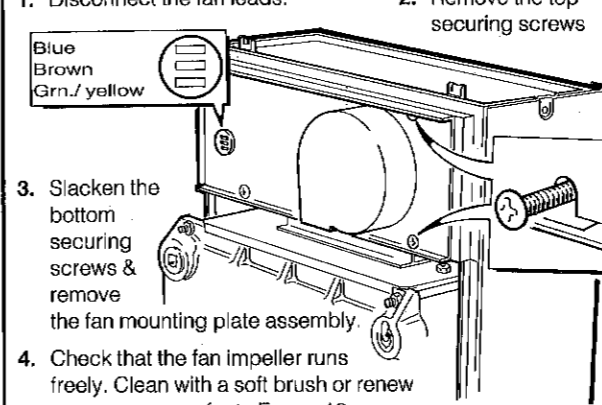

CLEANING & ADJUSTMENT- REPLACEMENT OF PARTS

6 CLEANING THE FLUEWAYS

- Remove the two top screws retaining the flue gas transfer duct mounted on the top of the cleanout cover.
- Slacken hook bolt nuts retaining the cleanout cover to the boiler casing. Turn both hook bolts anti-clockwise to disengage fixing & remove cleanout cover.
- Remove flue baffle.
- Remove all loose deposits from the heat exchanger, particularly between the fins, using a suitable brush.

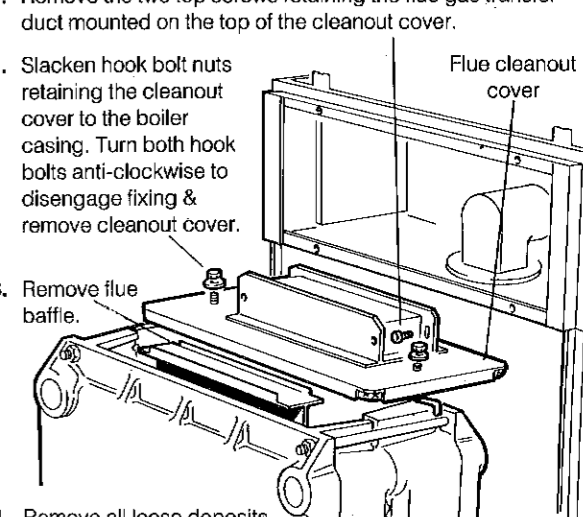

7 RE-ASSEMBLY

Re-assemble the boiler in the following order;

- Refit the flue baffle.
- Inspect the clean-out cover gaskets & replace if necessary. Re-fit the clean-out cover by pre-fitting the hook bolts, c/w washers & nuts, to the collector hood. Turn the hook bolts clockwise until the slot in the top of the bolt is parallel with the side of the boiler. This will engage the hook bolt under its fixing lug. Tighten both nuts & ensure that the sealing gasket is compressed.
- Refit the fan mounting plate assembly & reconnect fan leads.
- Refit the burner & controls assembly. Route & refit the boiler thermostat dial, refer to frame 18.
- Re-connect the ignition/ detection lead.
- Refit the control box cover.
- Re-connect the gas service cock and electrical wiring, refer to Frames 44- 46 'Installation'. Turn on the gas supply.
- Check the sightglass in the boiler casing. Clean or renew as necessary, refer to Frame 10.

- Check the pilot connection for gas soundness, refer to Frame 54- 'Installation', (also check gas cock & pressure test point).

- Refit the boiler casing and tighten the four captive screws.

IMPORTANT: When work is complete the casing MUST be correctly re-fitted. Ensure that a good seal is made (Frame 55 - 'Installation').

The boiler MUST NOT be operated if the casing is not fitted.

- For programmer models only: Angle the programmer to fit it into the controls casing from the front- push back to enable the external controls/ pump plug connector to be fitted & retain with the two fixing screws. Refit the mains supply plug to the programmer & the programmer plug to the control box socket. Retain the programmer to the boiler casing with the 4 screws previously removed.
- For non programmer models: Connect the mains supply plug to the control box.
- Refit the bottom panel to the casing surround (4 screws)
- Refit the controls pod door.

8 GAS PRESSURE ADJUSTMENT

- (a) Pilot** Light the boiler & check that the pilot flame is 25 mm long, refer to Frame 4. The pilot adjuster screw is factory set to maximum & no further adjustment should be necessary. However, if the pilot flame length is incorrect then proceed as follows;
- Turn the thermostat knob to OFF.
 - Remove the gas valve cover, by unscrewing central retaining screw.
 - Turn the pilot pressure adjuster screw CLOCKWISE until fully CLOSED, refer to Frame 56.

- Turn the pilot adjuster screw ANTI-CLOCKWISE four full turns to give maximum setting.

- Refit the gas valve cover.
- Relight in accordance with 'Initial Lighting', refer to Frame 54- 'Installation'.

- (b) Main burner** After any servicing, reference should be made to Table 2 which quotes details of the rated output with the related burner setting pressure & the heat input. Any required adjustments should be made by using the pressure adjustment screw. Refer to 'Initial Lighting', Frame 56- 'Installation'.

REPLACEMENT OF PARTS

9 GENERAL

When replacing any component;

- Isolate the electricity supply.
- Turn OFF the gas supply.
- Remove the boiler casing, refer to Frame 2.

IMPORTANT: When work is complete the casing MUST be correctly refitted, ensuring that a good seal is made.

The boiler MUST NOT be operated if the casing is not fitted.

10 SIGHTGLASS REPLACEMENT

- Refer to Frame 9.
 - Unfasten the two nuts & washers holding the sightglass assembly.
 - When fixing the new assembly ensure that the parts are in the correct order. Frame must have return edge at bottom.
 - To fit: Push frame studs through its face & refit sightglass assembly.
 - Replace boiler casing (Frame 7).

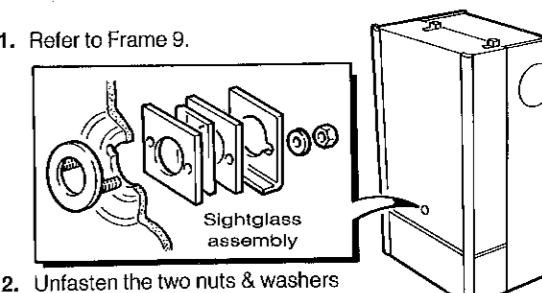

11 CONTROL THERMOSTAT REPLACEMENT

1. Refer to Frame 9.
2. Remove thermostat phial from pocket by slackening the screw holding the capillary retaining plate.
3. Unclip the capillary from the back panel.
4. Remove the two nuts retaining the thermostat sealing plate. Remove the plate and gasket. (inspect gasket and replace if necessary).
5. Remove the control box cover (1 screw).
6. Pull off the thermostat knob.
7. Pull off thermostat electrical connections at the plug marked '12' & '13' on the printed circuit board.
8. Remove the two screws retaining the thermostat to the control box & remove the thermostat & leads.
9. Transfer the electrical leads to the new thermostat (refer to Frame 48 for polarity). Fit new thermostat & re-assemble in reverse order, ensuring phial is correctly replaced in the pocket & capillary is routed as shown.
10. Replace the boiler casing, refer to Frame 7.
11. Check the operation of the new thermostat, refer to Frame 56.

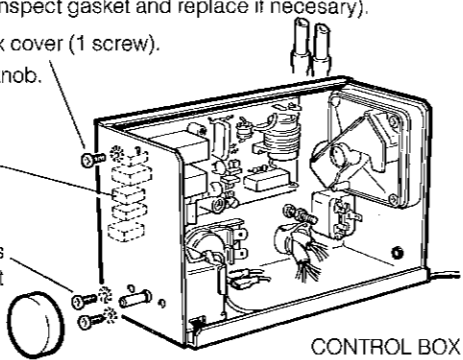
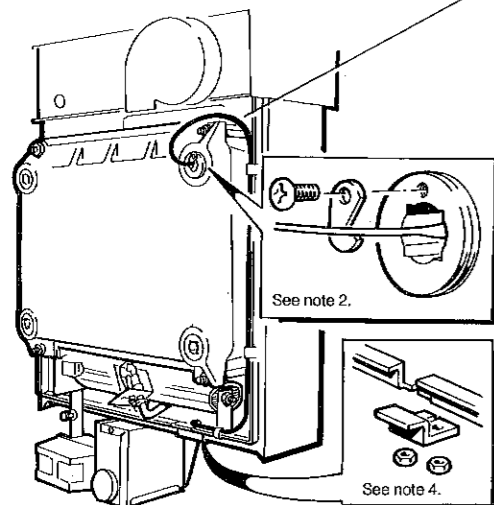

12 OVERHEAT THERMOSTAT REPLACEMENT (Optional extra for sealed systems only)

1. Refer to Frame 9
2. Remove the control box cover by undoing the single retaining screw.
3. Slacken the two screws retaining the capillary sensing head saddle bracket & pull the sensing head from the flow pipe.
4. Remove locknut retaining overheat thermostat to control box.
5. Remove the overheat thermostat from the control box & pull off the electrical connections. Unclip the capillary from it's retaining clip.
6. Fit both electrical connections to the new thermostat (polarity immaterial).
7. Re-assemble in reverse order ensuring the thermostat sensing head is correctly positioned under the saddle bracket. The capillary must be correctly routed and clipped. Re-tighten saddle bracket fixing screws.

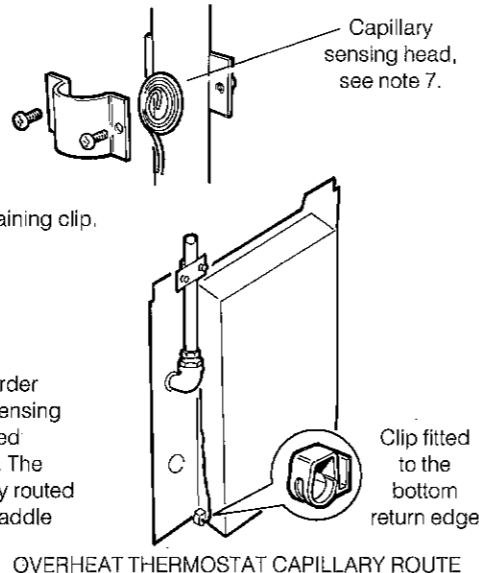
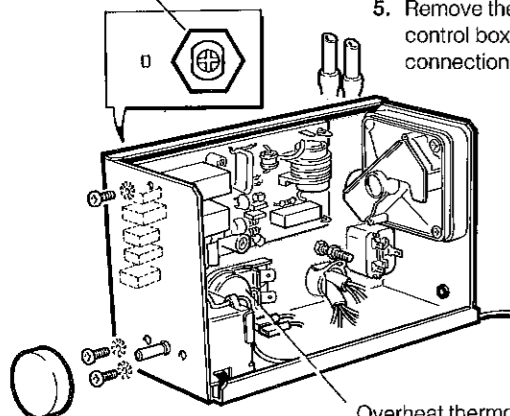

13 PILOT BURNER REPLACEMENT

1. Refer to Frame 9.
2. Undo the pilot pipe connection and ease clear of the pilot burner. DO NOT lose the pilot injector which is a push fit in the pilot burner housing, & may fall out as the pipe is removed.
3. Remove the two screws retaining the pilot burner to the main burner bracket.
4. Undo the electrode locking nut, Taking care not to damage or twist the integral lead then withdraw electrode.
5. Replace the pilot burner and re-assemble in reverse order. Ensure that the pilot injector is correctly fitted.
6. Check the pilot burner relationship and spark gap refer Frame 4.
7. Check for gas soundness of the pilot supply.
8. Replace the boiler casing, refer to Frame 7.
9. Check the pilot operation and the pilot flame length (25 mm), refer to Frame 4.

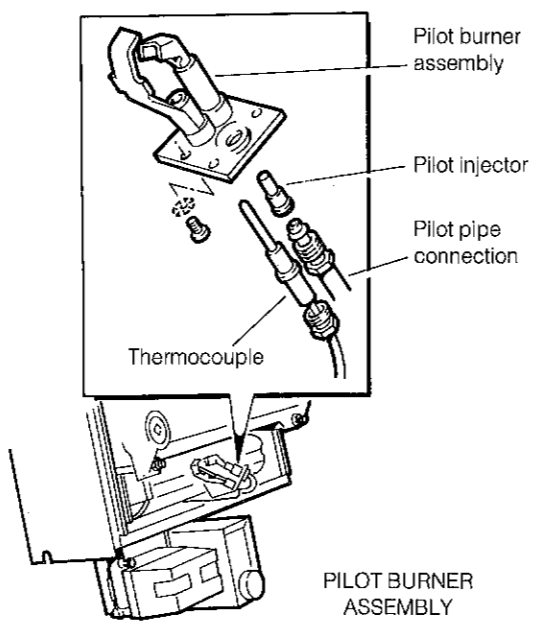
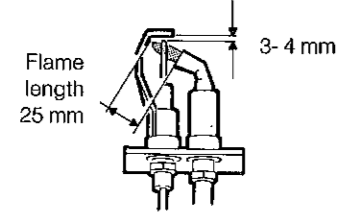

14 SPARK ELECTRODE & LEAD ASSEMBLY REPLACEMENT

1. Refer to Frame 9
2. Remove the control box cover (1 screw).
3. Remove the burner assembly, refer to Frame 3.
4. Remove the two screws retaining the sealing plate on the burner manifold plate and remove the sealing plate.
5. Pull the H.T. lead connection off the printed circuit board.
6. Feed the lead through the control box grommet, then carefully through the sealing plate gasket. Inspect gasket and replace if necessary.
7. Undo the electrode locking nut and withdraw the electrode complete with it's integral lead.
8. Fit the electrode and lead and re-assemble in reverse order.
9. Check the spark gap is correct, refer to Frame 4.
10. Replace the burner assembly
11. Replace the boiler casing, refer to Frame 7.
12. Check the ignition operation.

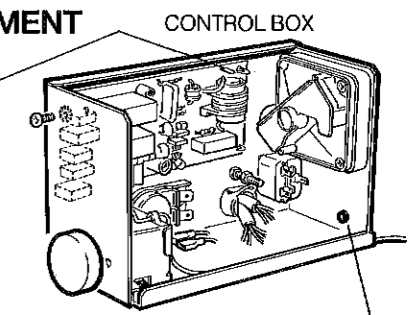
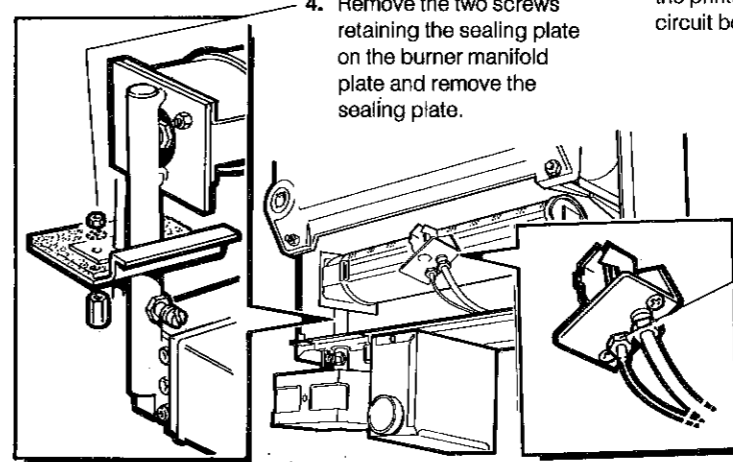

15 MAIN BURNER REPLACEMENT

1. Refer to Frame 9.
2. Remove the burner assembly, refer to Frame 3.
3. Remove the two screws retaining pilot burner assembly.
4. Remove the two nuts & washers securing the burner to the gas manifold.
5. Fit the new burner in reverse order, taking care not to damage the burner injector.
6. Refit the pilot burner assembly.
7. Refit the burner assembly.
8. Refit the boiler casing.
9. Check the burner operation.

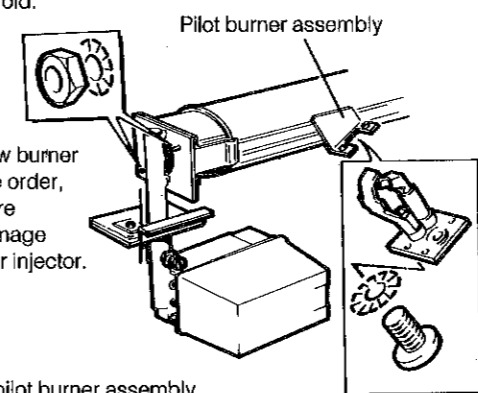

16 GAS VALVE REPLACEMENT

1. Refer to Frame 9.
2. Remove the burner & controls assembly, refer to Frame 3.
3. Undo pilot supply connection at gas valve.
4. Undo the four securing screws & washers. Transfer the inlet flange and gas service cock union to the new valve.
5. Undo the four securing screws and washers. Remove the burner manifold assembly and transfer to the new valve.
6. Fit the new gas valve, ensuring that;
 - (a) The sealing 'O' rings, supplied with the valve, are correctly fitted at the inlet and outlet flanges.
 - (b) The solenoid leads are correctly re-connected.
7. Re-assemble in reverse order.
8. Replace the burner/controls assembly
9. Replace the boiler casing.
10. Check for gas soundness. Pay particular attention to flanges.
11. Check the gas valve operation.

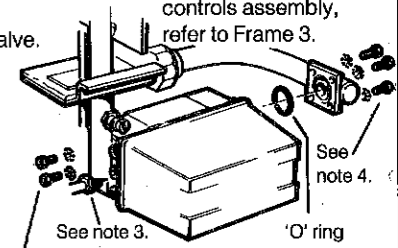

17 PILOT FILTER REPLACEMENT

1. Refer to frame 9.
2. Remove the burner & controls assembly, refer to Frame 3.
3. Remove the 5 screws securing the valve back plate and lift off the plate.
4. Pull out the pilot filter and discard.
5. Fit the new pilot filter and re-assemble in reverse order, taking care not to damage the cork gasket.
6. Refit the burner/controls assembly.
7. Refit the boiler casing.
8. Check the gas valve for gas soundness using leak detection fluid, refer to Frame 56.
9. Check the pilot and gas valve operation.

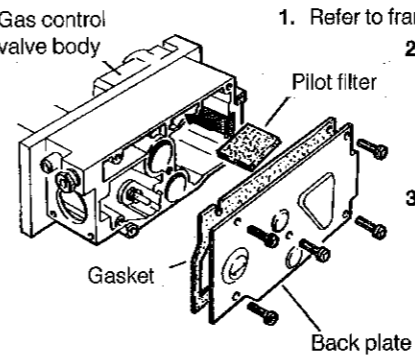

18 FAN UNIT REPLACEMENT

1. Refer to Frame 9.
2. Un-plug the 3 electrical connections to the fan plate.
 - blue
 - brown
 - gm./yellow
3. Slacken the bottom two fan plate fixing screws and remove the top two fixing screws.
4. Remove the fan unit.
5. Refit the new fan unit and re-connect all electrical leads.
6. Refit the boiler casing.
7. Check the boiler operation.

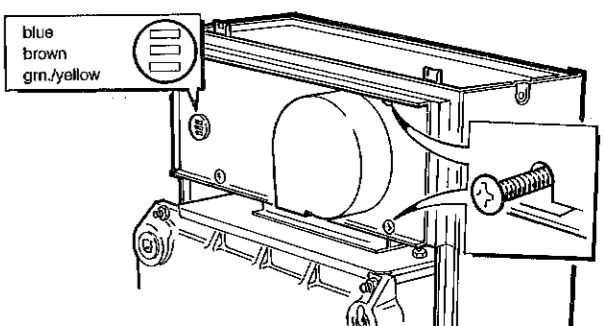

19 PRESSURE SWITCH REPLACEMENT

1. Refer to Frame 9.
2. Remove the control box cover.
3. Pull both of the sensing tubes off the aluminum pipes.
4. Pull off the pressure switch connector at the printed circuit board (marked '3', '4' & '5').
5. Remove the 2 pressure switch fixing screws.
6. Remove pressure switch and transfer both rubber pipes & electrical connections to the new pressure switch.
7. Refit new pressure switch & re-assemble in reverse order. Ensure the two rubber pipes are re-connected to the correct aluminium pipe (positive - positive, negative - negative)
8. Refit the boiler casing.
9. Check the boiler operation.

20 AUTOMATIC IGNITION PRINTED CIRCUIT BOARD REPLACEMENT

1. Refer to Frame 9.
2. Remove the control box cover (1 screw).
3. Disconnect the ignition/detection lead.
4. Disconnect the five plug-in leads.
5. Disengage the P.C.B. by compressing the 4 mounting pegs at the outside of the box with long nosed pliers.
6. Fit the new P.C.B. and re-assemble in reverse order.
7. Refit the boiler casing.
8. Check the ignition operation.

21 HEAT EXCHANGER REPLACEMENT

Note: Refer to Frame 23 of 'Exploded Views', on the next page for the illustration of any parts itemised below.

1. Refer to frame 9.
2. Remove the burner/controls assembly, refer to Frame 3.
3. Drain the system.
4. In order to remove the boiler from the wall it is necessary to disconnect all water connections at the rear of the heat exchanger. If this cannot be achieved because of limited side clearances, the pipes must be cut and then remade on re-assembly.
Note: If a sealed system kit is fitted then the flow pipe must be cut above overheat thermostat fixing bracket and a fill-in piece must be replaced upon re-assembly. The flow-pipe fitted with the overheat thermostat MUST NOT be discarded.
5. Remove the clean out cover assembly (item 3), refer Frame 6.
6. Remove the fan plate assembly (item 2), refer to Frame 18
7. Remove the aluminium elbow (item 6) and, for boilers fitted with a side outlet flue, the extension tube. Release and remove the flue locking ring and rubber seal.
8. Remove the screw retaining the bottom jacking plate (item 10) to the wall.
9. Remove the two wing nuts and plates (item 5) retaining the boiler to the mounting plate (item 7).
10. Lift the boiler off the wall mounting plate.
WARNING: The boiler is heavy.
11. Place the boiler on it's front and remove all water connections from the rear heat exchanger (item 1) tappings, including the distributor tube (item 9).
12. Remove the four M8 nuts retaining the heat exchanger to the back panel (item 8) and remove the panel.
13. Fit the back panel to the new heat exchanger.
14. Remove the thermostat pocket (item 12) from the old heat exchanger and fit it to the new heat exchanger. Plug any unwanted tappings with the recessed plugs provided. Use a suitable sealing compound for all connections.
15. Replace the distributor tube & all required water connections.
16. Replace the boiler on the wall and refit the flue baffle (item 4) correctly in the heat exchanger.

22 CASING SEAL REPLACEMENT

1. Refer to Frame 9.
2. Remove the old seal from the channel in the casing surround and replace with a new seal.
3. Replace the boiler casing, refer to frame 7.
17. Refit the bottom jacking plate wall fixing screw.
18. Refit the cleanout cover assembly, (replace gasket if necessary).
19. Remake the flue connection, i.e., aluminium elbow (item 6), extension tube (for boilers fitted with a side outlet flue only), rubber seal and the locking ring.
20. Refit the fan plate assembly (item 2).
21. Refit the burner assembly.
22. Refit the boiler casing, refer to Frame 7.
23. Remake all water connections. Refill the system and check for leaks.
24. Re-light the boiler and check the operating sequence.

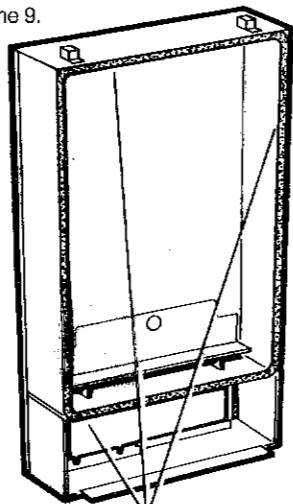

23 BOILER ASSEMBLY- Exploded view

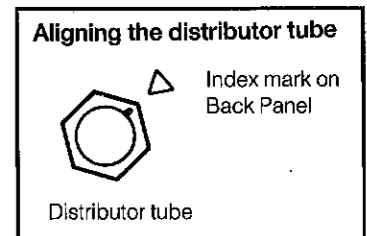
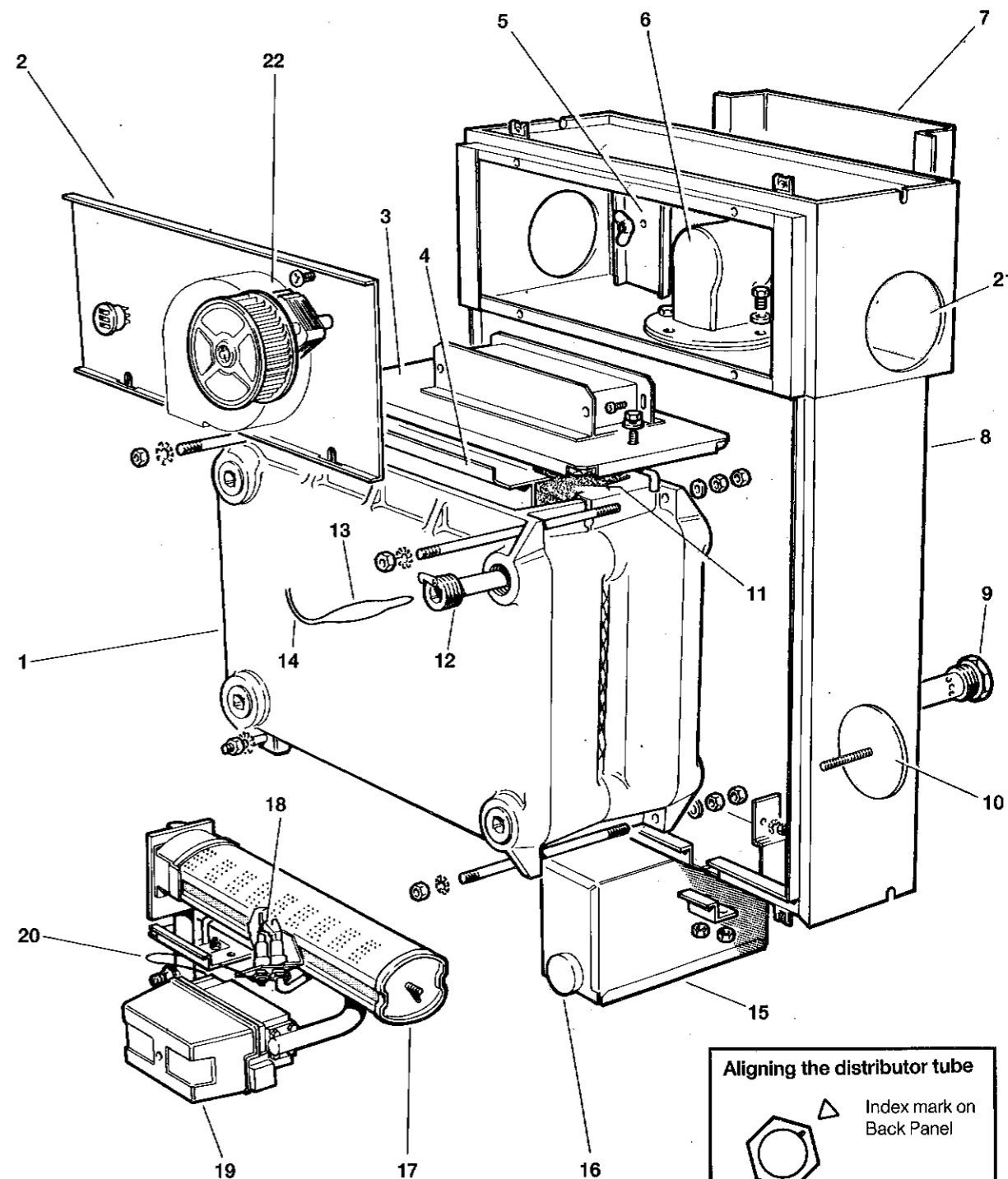

LEGEND

- | | |
|--|---|
| 1. Heat exchanger assembly | 12. Boiler thermostat pocket (left or right) |
| 2. Fan plate assembly | 13. Boiler thermostat phiil |
| 3. Clean- out cover assembly | 14. Thermostat capillary |
| 4. Flueway baffle | 15. Control box |
| 5. Sealing plates (2 off) | 16. Boiler thermostat |
| 6. Flue outlet elbow | 17. Main burner |
| 7. Wall mounting plate | 18. Pilot burner assembly |
| 8. Back panel | 19. Gas control valve |
| 9. Distributor tube (left or right, one side only) | 20. Thermocouple lead |
| 10. Jacking plate | 21. Side flue aperture (option of rear, left or right hand flue outlet) |
| 11. Heat exchanger flue | 22. Fan assembly |

24 BURNER ASSEMBLY- Exploded view

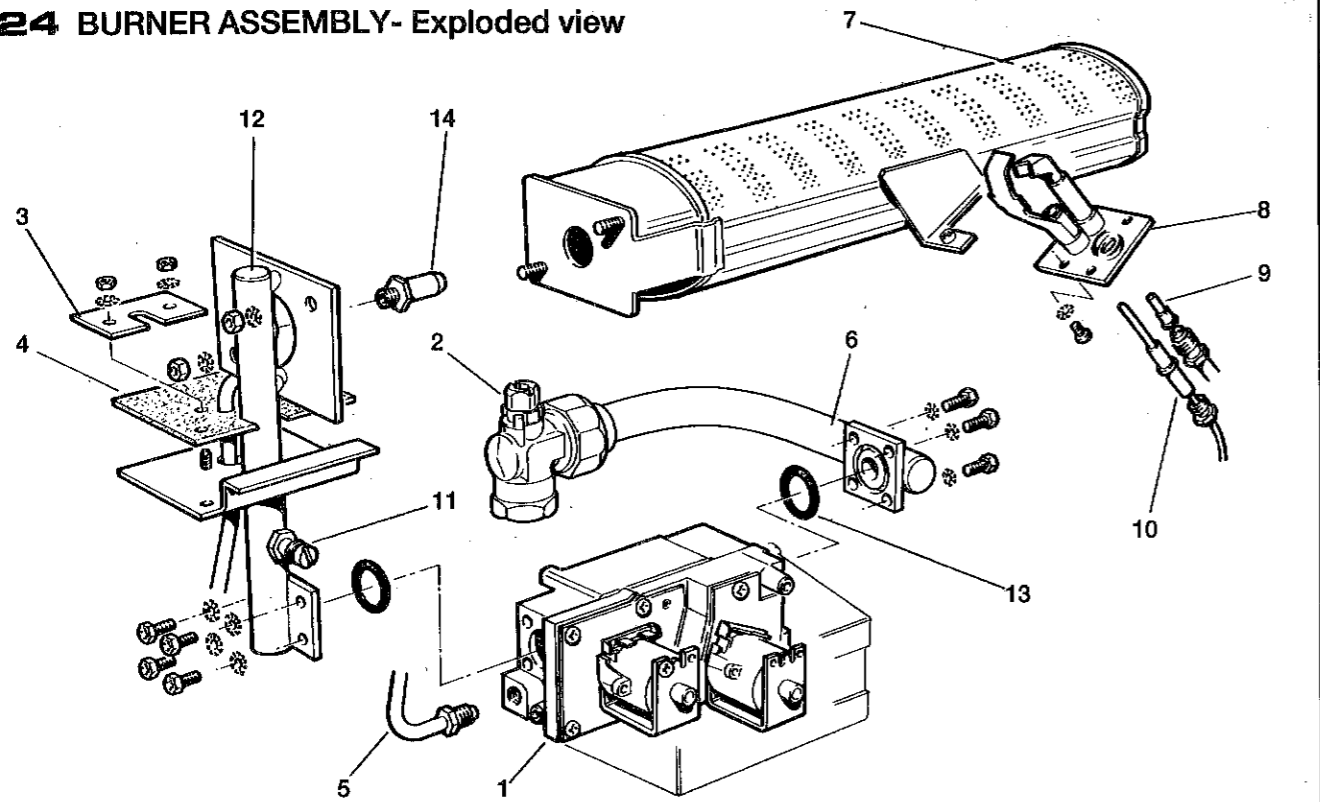

LEGEND

- | | | |
|----------------------------|-----------------------------------|--------------------------|
| 1. Gas control valve | 6. Gas inlet manifold | 11. Pressure test nipple |
| 2. Gas service cock | 7. Main burner | 12. Burner manifold |
| 3. Manifold sealing plate | 8. Pilot burner | 13. 'O' ring seal, 2 off |
| 4. Manifold sealing gasket | 9. Pilot injector | 14. Main burner injector |
| 5. Pilot supply | 10. Ignition/ detection electrode | |

25 CONTROL BOX ASSEMBLY- Exploded view

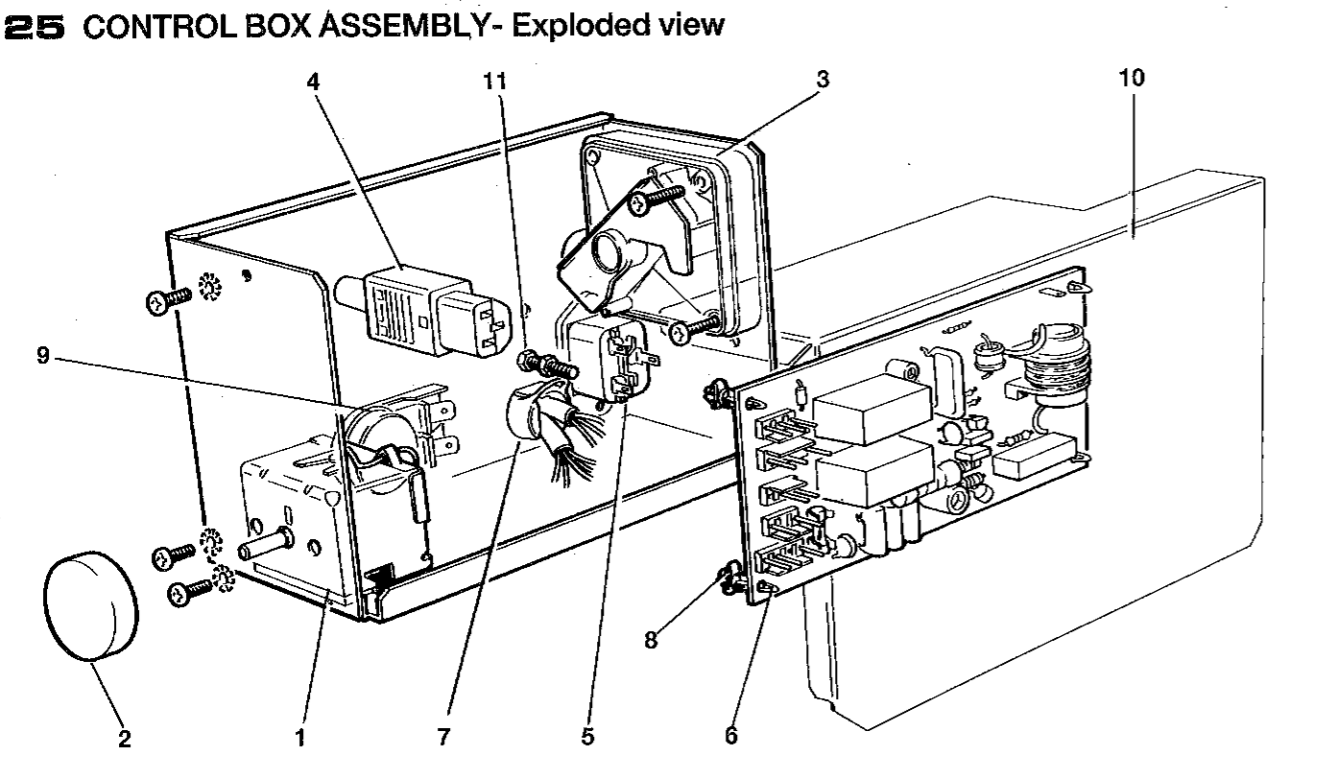

LEGEND

- | | | |
|---------------------------|---|---|
| 1. Boiler thermostat | 5. Mains input socket | 8. Printed circuit board mounting pegs, 4 off |
| 2. Boiler thermostat knob | 6. Automatic ignition printed circuit board | 9. Overheat thermostat (sealed systems only) |
| 3. Pressure switch | 7. Strain relief bush | 10. Control box cover |
| 4. Mains input plug | | 11. Earth post |

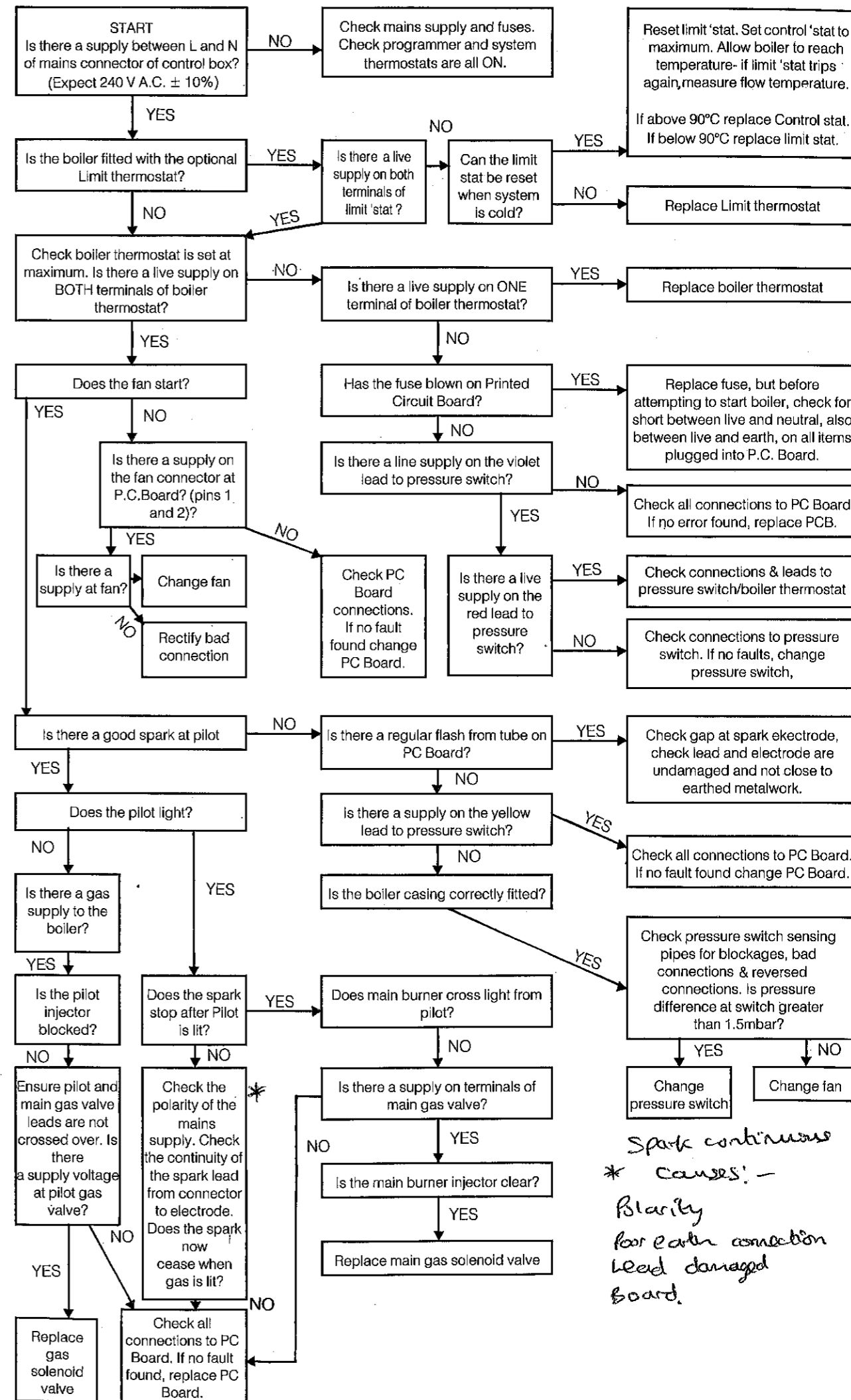

*Spark continuous
* Causes! -
Blarity
for earth connection
lead damaged
board.*

SPARES

SHORT LIST OF PARTS

Ideal W2000 30F, 40F, 50F & 60F GAS BOILERS

When ordering spares, please quote:

1. Boiler Model
2. Appliance G.C. Number
3. Description
4. Maker's Part Number
5. Quantity

The following list comprises parts commonly required as replacement components due to damage, expendability, or such that their failure, or absence, is likely to affect the safety or performance.

The list is extract from the British Gas List of Parts, which contains all available spare parts.

Details of the British Gas Lists are held by Gas Regions, STELRAD Distributors and by Merchants.

KEY No.	G.C. PART No	DESCRIPTION	No. OFF	MAKERS PART No
7	341 277	Sightglass assembly : comprising sight glass and frame, two gaskets, two M4 nuts and shakeproof washers.	1	189648175
10		Main burner - AEROMATIC No. AC 19/ 123241 - 30F, 40F & 50F No. AC 19/ 123239 - 60F	1	199414084 199444084
11		Main burner injector BRAY Cat 103 Size 950 - 30F BRAY Cat 103 Size 1150 - 40F BRAY Cat 103 Size 1500 - 50F BRAY Cat 103 Size 1900 - 60F	1	199516060 199526060 199536060 199546060
13		Pilot Burner - HONEYWELL Q389A Automatic 27F	1	199510083
12	381 791	Pilot burner injector - HONEYWELL 45003 508 005 56/42A	1	199 510 083
14	395 796	1/2in B.S.P. HONEYWELL Gas Control Valve VR4700E 1018, 240V, WITH 2 'O' Rings	1	586131300
17		Spark electrode with integral H.T. Lead 800mm long - VERNITRON	1	199 510 089
23	319 035	Automatic ignition printed circuit board - PACTROL 7A	1	589250068
20		Control thermostat, RANCO CL6 - PO 149	1	589410051
21	341 359	Control thermostat knob	1	586011517
30		Fan assembly complete SIFAN No.	1	589515025
24		Pressure switch - DUNGS LGW 3A1 1.2 mb	1	589515025
19		Control box assembly	1	199510065
22	354 776	Mains plug	1	589030015
32		Boiler casing assembly	1	199514030
37		Casing sealing pack	1	199510095
33		Casing removeable door with lighting instructions label.	1	199410089
50		Overheat thermostat (sealed systems) RANCO LM7 - P5025	1	199510056
51		Gasket set	1	199518098

PARTS LIST

SPARES

SPARE PARTS/CASING ASSEMBLY

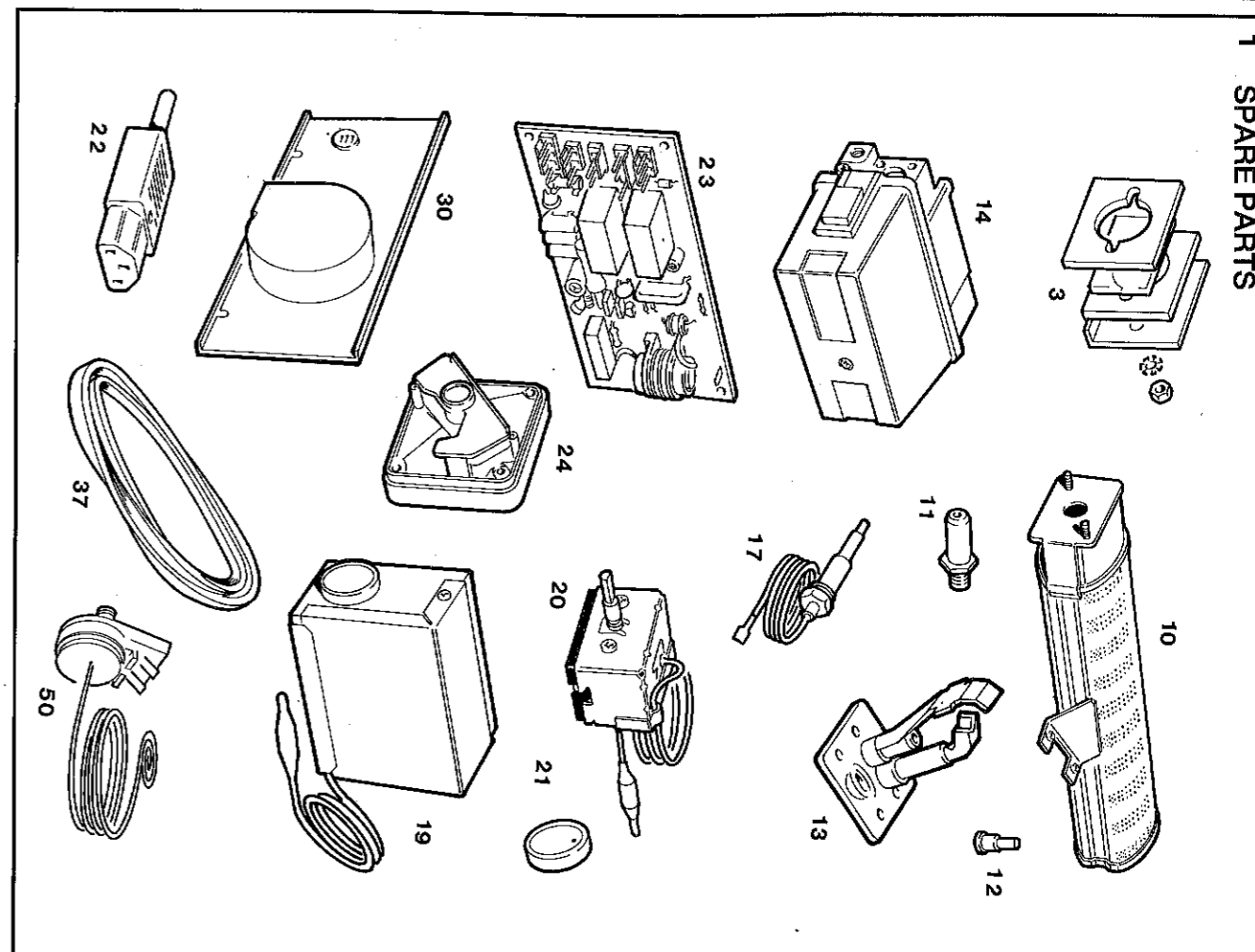

1 SPARE PARTS

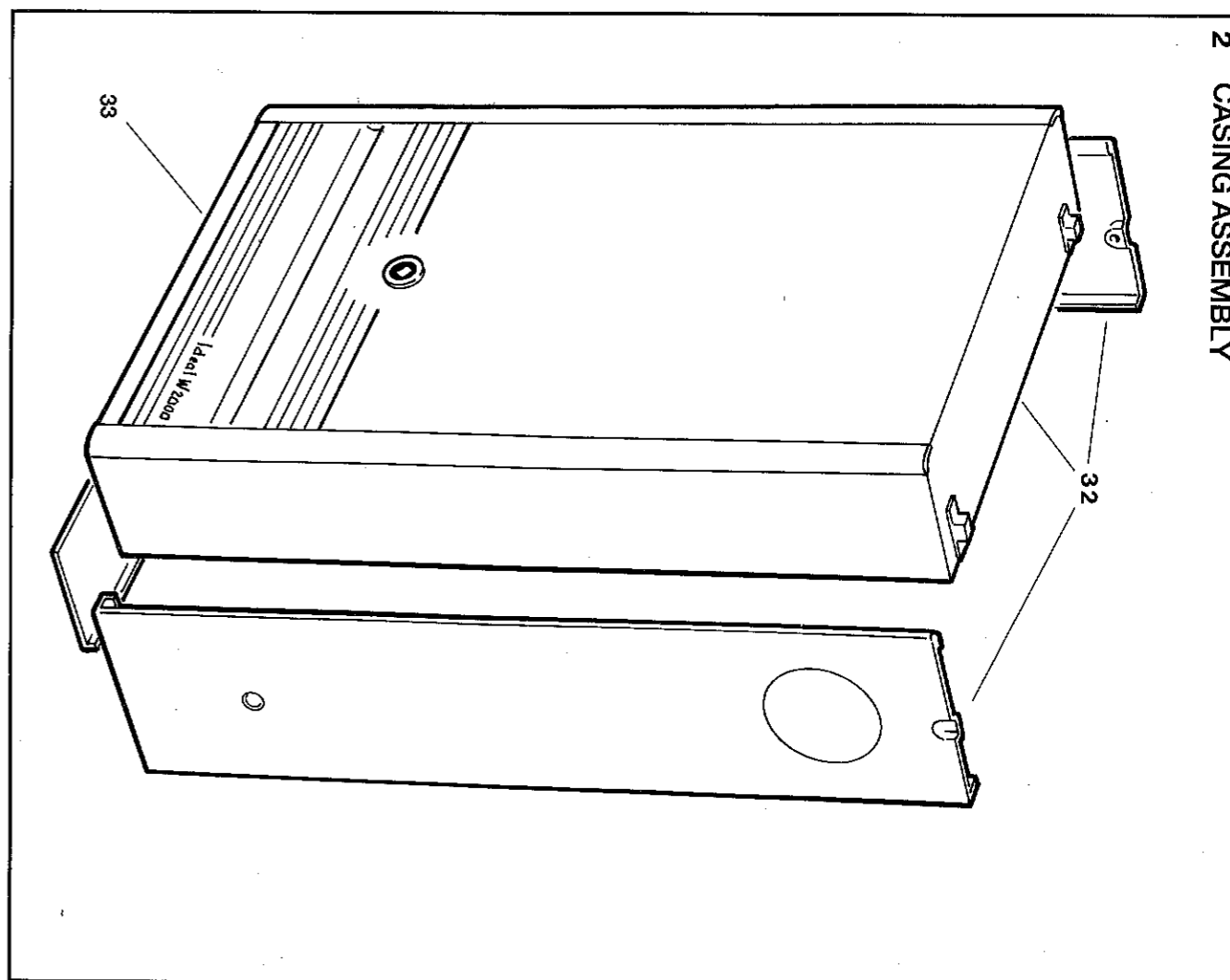

2 CASING ASSEMBLY

STELRAD GROUP pursues a policy of continuing improvement in design and performance of its products. The right is therefore, reserved to vary specification without notice.

STELRAD GROUP Limited

Sales and Marketing
Accord House, Goulton Street
Kingston upon Hull.

North Humberside. HU3 4DJ
Telephone: 0482 223673 Telex: 592786

Head and Registered Office;
Newtown Road, HENLEY-on-Thames. Oxfordshire
RG9 1HL

Registration No. London 322137

A SUBSIDIARY OF METAL BOX p.l.c.

H.0575 (1) 9/88

Printed in England.

