

IDEAL WLx

July, 1985

Ben

● RS 45P & 60P

Wall Mounted Balanced Flue Gas Boilers Installation & Servicing

CAUTION

To avoid the possibility of injury during the installation, servicing or cleaning of this appliance, care should be taken when handling the edges of sheet steel components.

NOTE: The appliances are for use with **PROPANE ONLY**

NOTE TO INSTALLER:

LEAVE THESE INSTRUCTIONS ADJACENT TO THE APPLIANCE.

●  **STELRAD
GROUP**

Boiler Size		RS. 45P	RS. 60P
Main Burner Bar		Bray Mk.9 AB.16638	Aeromatic 19/123213
Gas Control	½" BSP Honeywell Compact V.4600 A 1023 240v with regulator removed		
Burner Injector		Bray Cat. 10 Size 520	Bray Cat. 10 Size 650
Pilot Injector	Honeywell 45000062/012		
Gas Supply Connection	in.BSP	Rc½ ½	
Flow Connections	in.BSP	Rc1 1	
Return Connections	in.BSP	Rc1 1	
	in.BSP	Rc¾ ¾	
Maximum Static Water Head	m	36.6	
	ft	120	
Electric supply	220/240 volt 50 Hz		
External Fuse Rating	3 amp		
Water Content	litre	10.9	
	gal	2.4	
Dry Weight	kg	74.0	
	lb	163.0	
Maximum Installation Weight	kg	57.6	
	lb	127.0	

Boiler Size		RS. 45P	RS. 60P
Boiler Input **	MAXIMUM kW	17.5	21.8
	Btu/h	59 600	74 200
Boiler Output to Water	MAXIMUM kW	13.5	16.7
	Btu/h	46 000	57 000
Burner Setting Pressure	mbar (gauge)	35.4	35.6
	in. w.g.	14.2	14.3
Inlet Setting Pressure	mbar (gauge)	37.0	37.0
	in. w.g.	14.9	14.9

Note: **
To obtain gas consumption:
(a) in l/s — divide heat input (kW) by C.V. of the gas (MJ/m³),
(b) in ft³/h — divide heat input (Btu/h) by C.V. of the gas (Btu/ft³).

INTRODUCTION

The IDEAL ELITE RS. 45P and 60P are wall mounted, balanced flued, natural draught gas boilers, having outputs of 13.5 kW (46 000 Btu/h) and 16.7 kW (57 000 Btu/h).

The boiler is supplied with an insulating blanket of aluminium foil backed fibre glass, covering the front and sides of the boiler body, and held in place by a securing strap — refer Fig. 1.

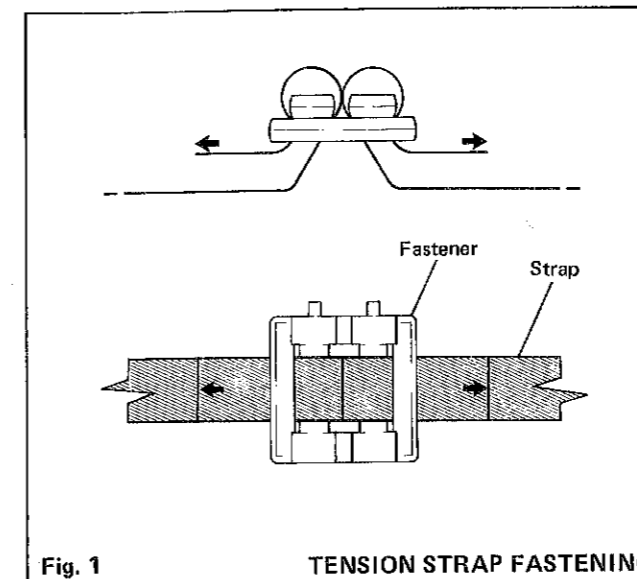

The boiler casing, and controls access door, are of mild steel, white enamelled, with the controls pod sides, and push-on pipe concealment plates, coloured mid-brown.

The boiler thermostat is located behind the controls access door, in the box mounted on the gas valve.

Programmer and pump kits, which fit neatly within the casing, are available as OPTIONAL EXTRAS.

The pump kit is suitable for mounting on the right hand side flow or return tapplings ONLY.

Separate fitting instructions are included with these kits. The boilers are suitable for connection to open vented systems ONLY.

The systems may be pumped, or gravity circulating indirect domestic hot water only, pumped central heating only, or pumped central heating combined with either a pumped, or gravity circulating, indirect domestic hot water circuit.

Note: A distributor tube, packed in the bag of fittings, is supplied with each boiler.

On all systems with fully pumped circulation, only ONE boiler return tapping may be used, even if independent circuits for hot water and central heating are provided, each with its own pump.

The distributor tube MUST be fitted into the tapping used for the return from the pumped system, even if domestic hot water is by gravity circulation.

Adequate arrangements for completely draining the system, by provision of drain cocks, MUST be provided.

IMPORTANT

Gas Safety Regulations, 1972:

It is the law that all gas appliances are installed by competent persons (e.g. CORGI, identified by ) in accordance with the above Regulations. Failure to install appliances correctly could lead to prosecution.

It is in your own interest, and that of safety, to ensure that the law is complied with.

The installation of the boiler MUST also be in accordance with I.E.E. Regulations, the by-laws of the Local Water Undertaking, any relevant requirements of the Local Authority, and the relevant recommendations of the following British Standards:

Codes of Practice:

- BS.5482:1 Domestic butane and propane gas burning appliances.
- BS.5376:2 Boilers of rated input not exceeding 60 kW.
- BS.5449:1 Forced circulation hot water systems (smallbore and microbore domestic central heating systems).
- BS.5546 Installation of gas hot water supplies for domestic purposes (2nd Family Gases).
- BS.5440:1 Flues (for gas appliances of rated input not exceeding 60 kW).
- BS.5440:2 Air supply (for gas appliances of rated input not exceeding 60 kW).

Manufacturer's notes must NOT be taken, in any way, as over-riding statutory obligations.

LOCATION OF BOILER

The wall MUST be flat and vertical, and of a suitable load bearing capacity. The boiler may be fitted on a combustible wall, and insulation, other than that required by the Local Authority and Building Regulations, is NOT necessary.

The boiler MUST be installed on an external wall.

The boiler may be installed in any room, although particular attention is drawn to the requirements of the I.E.E. Regulations and, in Scotland, the electrical provisions of the Building Regulations applicable in Scotland, with respect to the installation of the boiler in a room containing a bath or shower.

Where installation will be in an unusual position, special procedures may be necessary, and BS.5482:1 gives detailed guidance on this aspect.

A compartment used to enclose the boiler MUST be designed and constructed specially for this purpose. An existing cupboard or compartment may be used provided it is modified for the purpose.

Details of the essential features of cupboard/compartment design, including airing cupboard installations are given in BS.5482:1.

In siting the boiler, the following limitations MUST be observed:

1. The position selected for installation MUST allow adequate space for servicing in front of the boiler.
Side clearance is only necessary for installation. The amount of side clearance will depend on the type of connections used.
Where side units are modified to facilitate installation, then NO clearance is required.
2. This position MUST also permit the provision of a satisfactory balanced flue termination.

GAS SUPPLY

The Local Propane Gas Supplier should be consulted at the installation planning stage in order to establish the availability of an adequate supply of gas.

Installation pipes, cylinders and pressure regulators should be fitted in accordance with BS.5482:1. Bulk tank installations must comply with the requirements of the Home Office code of practice for the storage of liquified petroleum gas at fixed installations.

The complete installation MUST be tested for soundness as described in the above standard.

FLUING

Detailed recommendations for fluing are given in BS.5440:1.

The following notes are intended for general guidance:

- The appliance MUST be installed so that the flue terminal discharges directly into the external air.
- Termination should be on a clear expanse of wall, the terminal being preferably NOT less than 600mm (24in) away from a corner, recess or projection.
- Do NOT install the terminal:
 - Within 300mm (12in), measured vertically, from the bottom of an openable window, air vent, or any other ventilation opening.
 - Within 300mm (12in) above adjacent ground level.
 - Within 600mm (24in) of any surface facing the terminal.
 - Immediately below eaves or a balcony.
 - Where it is subject to accidental obstruction.
- Where the lowest part of the terminal is less than 2m (6.6ft) above the level of any ground, balcony, flat roof, or place to which people have access, the terminal MUST be protected by a guard of suitable material.

The dimensions of the guard shall be such that, when fitted in accordance with the Manufacturer's instructions, it shall be at least 50mm (2in) from any part of the terminal, NOT including the wall plate.

The guard shall NOT have any sharp edges likely to cause injury, nor shall ANY opening permit the entry of a ball of 16mm (5/8in) diameter under a force of 5N.

The material finish and mechanical strength of the guard shall be such as to ensure a reasonable life in normal working conditions.

The guard shall NOT affect the performance of the appliance.

Terminal guards are available from:

Quinnel, Barret & Quinnel Ltd., 884 Old Kent Road, London SE 15, and from Tower Flue Components Ltd., Vale Rise, Tonbridge, Kent. TN9 1TB.

- The air inlet/products outlet duct and the terminal of the boiler MUST be NOT closer than 50mm (2in) to combustible material.

Detailed recommendations on protection of combustible material are quoted in BS.5440:1.

IMPORTANT

It is absolutely ESSENTIAL to ensure, in practice, that products of combustion discharging from the terminal, cannot re-enter the building, or any other adjacent building, through ventilators, windows, doors, other sources of natural air infiltration, or forced ventilation/air conditioning systems.

If this eventuality should occur, the appliance MUST be

turned OFF immediately and the Local Propane Gas Supplier called in to investigate.

BOILER TERMINAL

The terminal box of the balanced flue, with the addition, if necessary, of a duct extension, can be adapted to accommodate various wall thicknesses — refer 'Packaging'.

AIR SUPPLY

Detailed recommendations for air supply are given in BS.5440:2, the following notes being intended for general guidance.

It is NOT necessary to have a purpose provided air vent in the room in which the boiler is installed.

If the boiler is to be installed in a cupboard or compartment, permanent air vents are required, for cooling purposes, in the cupboard/compartment, at both high and low levels.

The air vents may communicate with a room/internal space or direct to outside air.

The minimum effective areas of the permanent air vents, required in the cupboard/compartment, are as follows:

RS. 45P

Position of air vent	Air from room/ internal space	Air direct from outside
High Level $\frac{\text{cm}^2}{\text{in}^2}$	156 24	78 12
Low Level $\frac{\text{cm}^2}{\text{in}^2}$	156 24	78 12

RS. 60P

Position of air vent	Air from room/ internal space	Air direct from outside
High Level $\frac{\text{cm}^2}{\text{in}^2}$	198 32	99 16
Low Level $\frac{\text{cm}^2}{\text{in}^2}$	198 32	99 16

Note: Both air vents MUST communicate with the same room, or internal space, or must both be on the same wall to outside air.

WATER CIRCULATION SYSTEM

The appliance must NOT be used for direct hot water supply, or for sealed systems.

The appliance is suitable for connection to pumped, open vent central heating systems; pumped central heating combined with pumped, or gravity, indirect domestic hot water systems; gravity, or pumped, indirect domestic hot water supply systems.

The appliances are NOT suitable for gravity central heating systems with, or without, additional gravity domestic hot water supply, nor are they suitable for the provision of gravity domestic hot water requirements above a 181.8 litre (40 gal) tank capacity, depending on the model.

The resistance of the boiler is, at 16.7 kW (57 000 Btu/h) output, with an 11°C (20°F) temperature difference, approximately 49mbar (19.7 in.w.g) — refer Table 3.

Table 3
WATER FLOW RATE and PRESSURE LOSS

Boiler Size		RS 45P	RS 60P
Boiler Output	kW Btu/h	13.5 46 000	16.7 57 000
Water Flow Rate	l/min gal/h	17.4 230	21.6 285
Pressure Loss	mbar in.w.g.	32 12.8	49 19.7

AVOID flow rates in excess of the above values as this may result in an excessive pressure drop across the boiler.

Note: The above table is based on a temperature rise across the boiler of 11°C (20°F).

Hydraulic pressure losses quoted are for boilers fitted with a distributor tube.

The central heating system should be in accordance with the relevant recommendations given in BS.5376:2 and, in addition, for small bore and microbore systems — BS.5449:1.

The domestic hot water system, if applicable, should be in accordance with the relevant recommendations of BS.5546.

Copper tubing, to BS2871:1, is recommended for water carrying pipework.

The hot water storage cylinder MUST be of the indirect type, and should be preferably, manufactured of copper. The hot water cylinder, and ancillary of pipework, not forming part of the useful heating surface, should be lagged to prevent heat loss and any possible freezing, particularly where pipes run through roof spaces and ventilated under floor spaces.

The flow and return connections to a fully pumped system may be made either at one side of the boiler, or diagonally, to suit convenience.

In a combined pumped heating and gravity domestic hot water system, the gravity flow and return connections MUST be made to the same side of the boiler, and the pumped connections to the OPPOSITE side.

The distributor tube MUST be fitted into the tapping used for the return from ALL pumped systems — refer to further note under 'Preparing the Appliance' in the Installation section of this publication.

The boiler thermostat phial, and pocket, MUST be fitted in the front upper tapping, on the same side of the boiler as that selected for the pumped return.

When using the IDEAL WLx pump kit, the flow or return tapping chosen MUST ALWAYS be made to the right hand side of the boiler.

The boiler MUST be vented. If venting cannot be done via a flow connection, a separate vent MUST be fitted by the installer.

This does NOT mean that more than one open vent is required. Other parts of the system, which may become unavoidably air locked, can be automatically vented.

Draining taps MUST be located in accessible positions, which permit the draining of the whole system, including the boiler and hot water storage vessel. Draining taps should be, at least 1/2in. nominal size and be in accordance with BS.2879.

ELECTRICAL SUPPLY

External wiring MUST be in accordance with the I.E.E. Regulations and any Local Regulations which apply.

The boiler is supplied for 220/240 volt, 50 Hz, A.C. Single Phase. Fuse rating is 3-amp.

The method of connection to the mains electricity supply should facilitate complete electrical isolation of the boiler, preferably by the use of a fused three-pin plug and shuttered socket-outlet, both complying with the requirements of BS.1363.

Alternatively, a fuse-double pole switch, or fused spur-box, serving only the boiler, may be used.

The point of connection to the mains should be readily accessible and adjacent to the boiler, except that, for bathroom installations, the point of connection to the mains MUST be situated outside the bathroom.

INSTALLATION

Allow adequate space in front of the boiler for servicing purposes.

PACKAGING

The boiler is supplied fully assembled and despatched in one carton 'A' together with one or two of four cartons — 'B', 'B1', 'C' or 'D'.

Carton 'A' contains the boiler body assembly, mounted on a wooden cradle, a bag of fittings, the wall mounting plate, two push-on side plates, the wall template and the User's Instructions.

Keep the carton the right way up, in accordance with the markings on the outside.

Cartons 'B', 'B1' and 'C' contain the terminal outlet appropriate to the wall thickness, and carton 'D' contains the duct extensions — refer Table 4.

Table 4 Wall Thickness

Thickness	No. of Cartons Supplied	Cartons Supplied
mm 114 – 191 in 4½ – 7½	2	A + C
mm 229 – 305 in 9 – 12	2	A + B
mm 318 – 394 in 12½ – 15½	3	A + B1
mm 406 – 584 in 16 – 23	3	A + B + D

It is most IMPORTANT that this appliance be installed in a vertical position with the flue/air duct passing through the wall in a horizontal plane.

A minor deviation from the horizontal is acceptable, provided that this results in a downward slope of the flue/air duct away from the boiler.

Two jacking screws, located beneath the air duct, are provided to facilitate boiler alignment.

The boiler is to be hung on an external wall, and the space in which it is fitted MUST have the following minimum dimensions:

Width	—	540mm (22in)
Depth	—	350mm (14in)
Height	—	1040mm (41in)

This space includes the following minimum clearances for installation and servicing:

At the top of the boiler	—	150mm (6in)
At each side of the boiler	—	25mm (1in)
Underneath the boiler	—	150mm (6in)

In addition, a minimum clearance of 350mm (14in) MUST be available at the front of the boiler to enable the appliance to be serviced.

To facilitate installation and the removal of the boiler from the wooden cradle, the casing MUST be removed — refer Fig. 2.

Remove the controls pod by pulling it upwards.

Disconnect the green/yellow earth bonding wire from the stud located on the underside of the boiler casing.

Remove the four wing nuts — refer Fig. 2 — securing the boiler casing to the backplate, and lift the casing off the boiler.

The casing should be safely placed aside to avoid possible damage.

Remove the wall mounting plate and bag of fittings, packed on the floor of the cradle.

PREPARING THE WALL — Refer Fig. 5

Tap the template to the wall in the selected position.

Mark out the position of the three mounting plate screws, choosing one from each group of three, also mark the position of the hole for the duct.

Ensure the chosen positions are satisfactory, i.e. not in the way of a mortar course, etc.

Drill the three holes with a No. 20 (10mm — 3/8in) masonry drill and insert the three TP 3 plastic plugs provided.

Cut the appropriate hole in the wall for insertion of the terminal assembly.

The terminal box must NOT come into contact with combustible material, such as that used in non-standard construction of timber framework and plasterboard, etc.

If an optional pump kit is to be used, drill the two appropriate holes with a No.20 (10mm — 3/8in) masonry drill and insert the two TP3 plastic plugs.

Secure the mounting plate to the wall with the three 8mm x 50mm (5/16in x 2in) coach screws provided.

Note:

This type of fastening is suitable for use with conventional brick, or breeze block, walls. Where unconventional materials are used, the installer should use fasteners compatible with the material involved.

PREPARING THE APPLIANCE

Screw the distributor tube into the selected return tapping, using approved jointing compound.

Screw the distributor tube home, with the arrow on the boiler backplate in alignment with the index mark on the distributor tube bushing — refer Fig. 3.

Note: To facilitate the fitting of the distributor tube, the side plate bracket, located on the lower tie rod, may be temporarily removed.

If an optional pump kit is to be used, it must be fitted at this stage — refer to the separate fitting instructions included with the kit.

Screw the boiler thermostat pocket and bush, supplied in the bag of fittings, into the front upper tapping on the side selected for the pumped return connection, using approved jointing compound.

Insert the thermostat phial into the pocket, and fasten it in position with the split pin provided.

Unfasten the two screws securing the gas supply pipe clamp to the backplate, and remove the clamp.

Route the capillary tube between the backplate and the clamp, and secure it with the spring clips, as shown in Fig.6.

Note:
Arrows indicate removal.
Reverse direction for fitting.

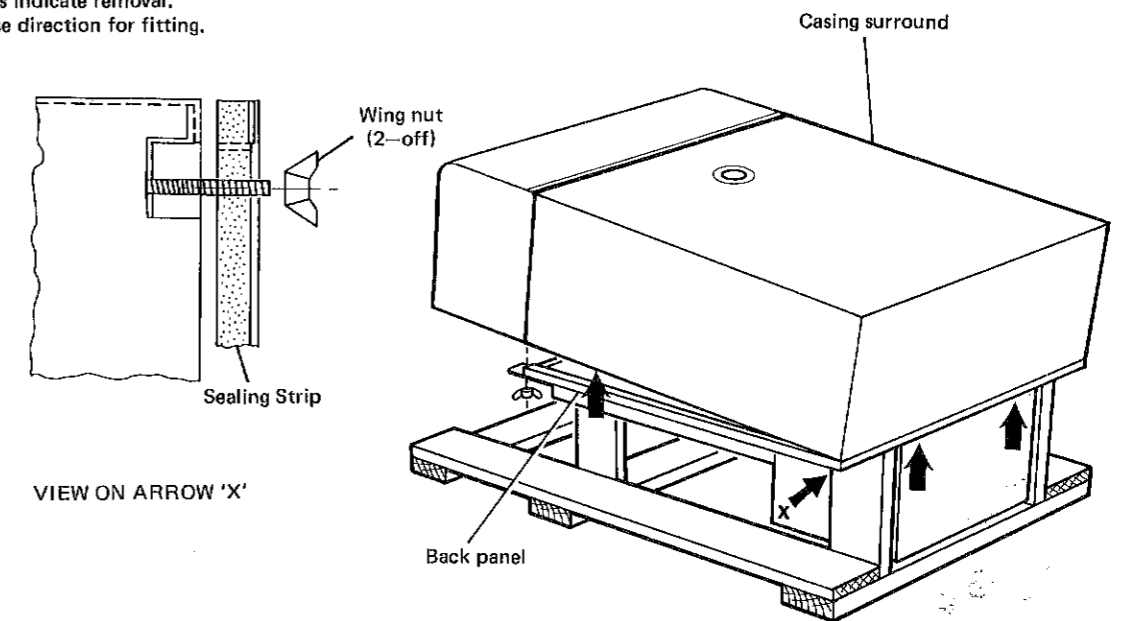

Fig. 2

CASING ARRANGEMENT

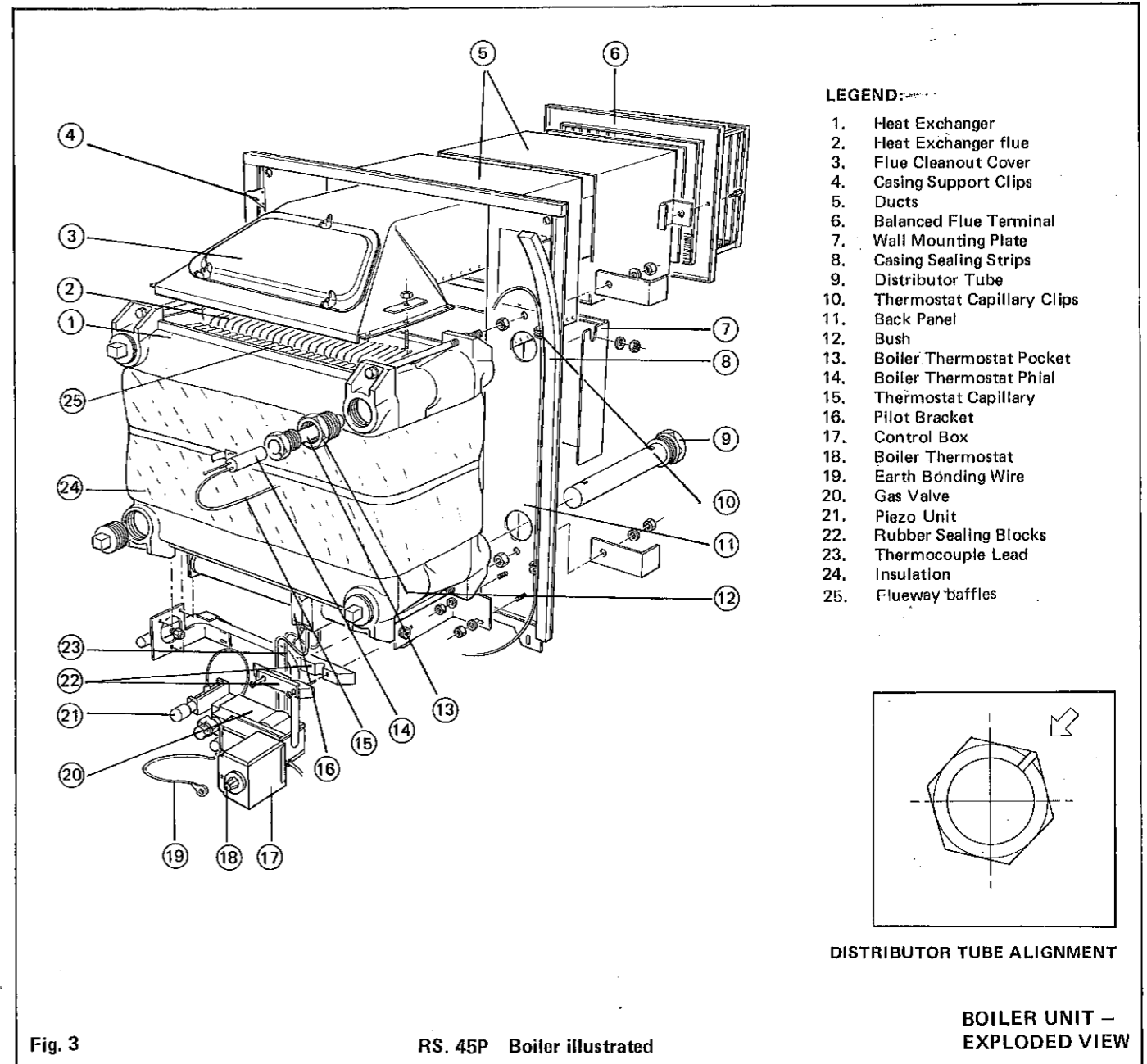

Fig. 3

RS. 45P Boiler illustrated

All Dimensions in mm (in)

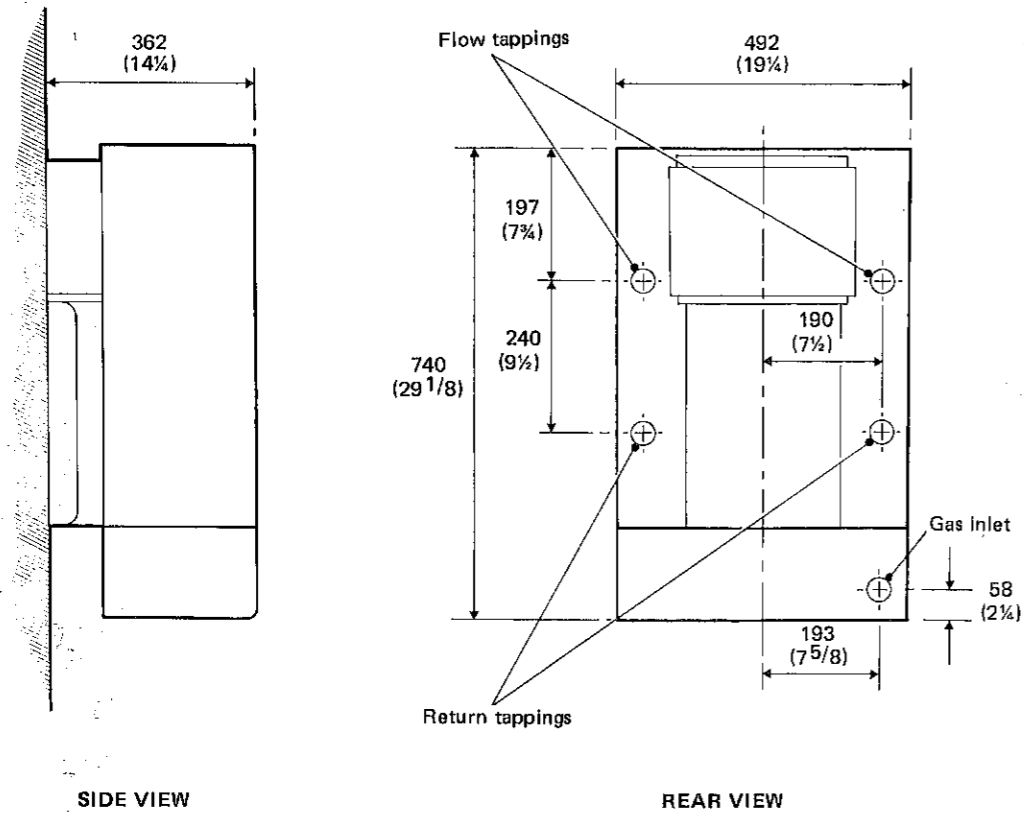

Fig. 4 DIMENSIONS

All Dimensions in mm (in)

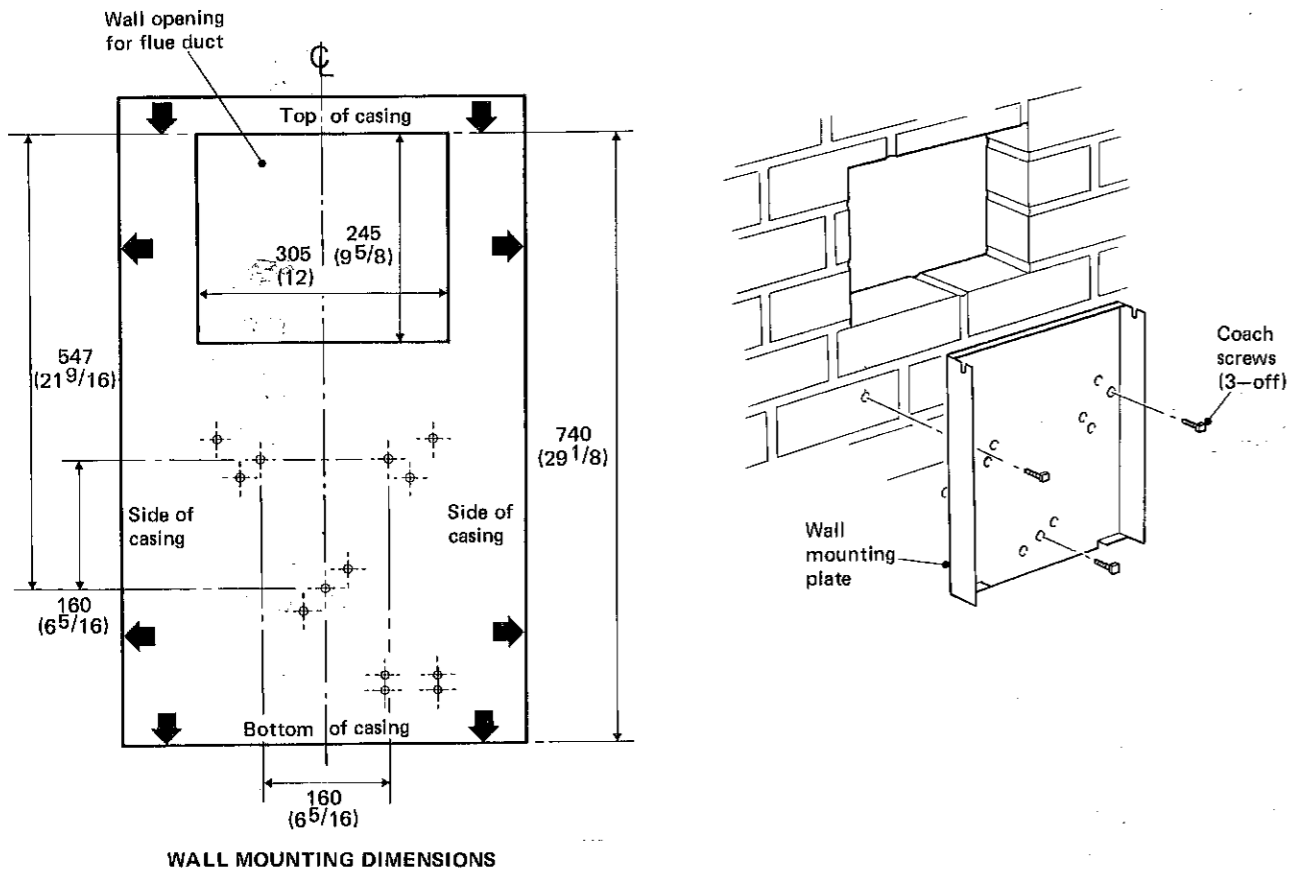

Fig. 5 WALL MOUNTING DIMENSIONS TEMPLATE AND WALL MOUNTING PLATE

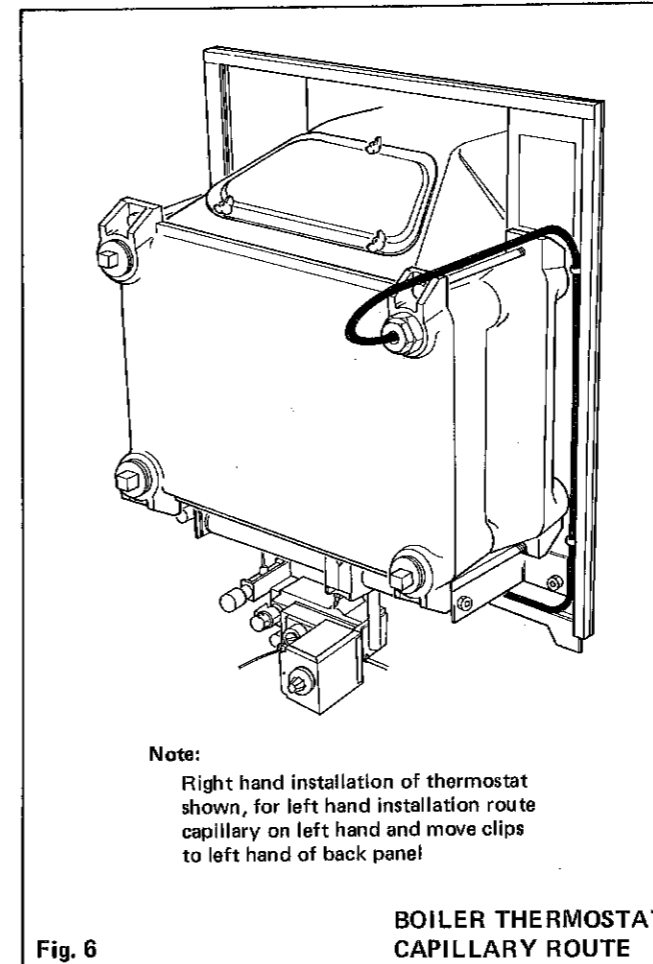

Fig. 6 BOILER THERMOSTAT CAPILLARY ROUTE

Replace the pipe clamp.

Stub connections may now be made to the flow and return tappings — made with copper pipe and approved compression fittings, and terminating with unions projecting clear of the boiler casing.

Take care NOT to rotate the distributor tube when screwing the fitting into the pumped return tapping.

Tightly plug any tappings not used, with the plugs provided in the bag of fittings, using approved jointing compound.

To fit the push-on side plates, the gas and water connections MUST run within the space enclosed.

Gravity domestic hot water piping, and fittings, MUST be 28mm (1in), smaller pipe and fittings MUST NOT be used.

Whilst 22mm (3/4in) piping, and fittings, may be used for the central heating flow and return pipes, to and from the boiler, the boiler FLOW tappings SHOULD NOT be bushed down directly when fitting either a separate 22mm (3/4in) open vent, or a common 22mm (3/4in) flow pipe to a fully pumped system, otherwise inadequate air venting from the boiler may result.

When pumped system load exceeds 13kW (44 000 Btu/h), 28mm (1in) pipework should be used to and from the boiler.

This will mean bushing down from 28mm (1in) to 22mm (3/4in), JUST BEFORE entry into the distributor tube fitted into the boiler return tapping.

FITTING TO THE WALL

Lift the boiler on to the wall mounting plate, entering the projecting flue duct into the opening cut in the wall, and lowering the two suspension studs into the slotted bearers at the top of the wall mounting plate side angles.

Using the jacking screws, provided beneath the air duct, adjust as necessary until the flue duct is horizontal. Check alignment with a spirit level.

Fit the M8 washers and nuts, provided in the bag of fittings, and secure the boiler in position.

WATER CONNECTIONS — Refer Fig. 7

The water connections can now be completed, the system filled and vented, connections checked for leaks and, if necessary, made good. This operation should be effected before making good the brickwork around the wall opening as a leak at the boiler tappings may require temporary removal of the boiler from the wall.

This appliance is NOT suitable for use in either a sealed system, or a direct system.

Pipework connections to all systems may use flow and return connections on the same side, or opposite sides, of the boiler. That is:

Fully Pumped System —

Either a L.H. or a R.H. flow connection, together with a L.H. or R.H. return connection, may be used.

This does NOT apply when using the IDEAL WLx pump kit which is suitable for mounting on the right hand side flow or return tappings ONLY.

Gravity Domestic Hot Water and Pumped-Central Heating —

Separate flow and return connections are used for each service.

The gravity connections MUST be made to one side of the boiler and the pumped connections to the opposite side.

During Summer operation, when the central heating is OFF, the use of a cylinder thermostat is recommended. This will prevent excessive domestic hot water temperatures and thus reduce gas consumption.

The pipe runs for gravity circulation should be planned with reference to the diagram and graph illustrated in Fig. 7.

The graph has been calculated on the assumption that NOT more than eight elbows are used in the gravity loop, including entry to the boiler.

For each extra elbow in excess of eight, (R) must be reduced by 300mm (12in), or (H) increased by 100mm (4in).

Whatever value is selected for (R), i.e. the horizontal distance between the centre line of the cylinder and the boiler tappings used, measured along the pipe run, the value of (H), i.e. the vertical distance between the top of the boiler and the base of the cylinder, MUST be, at least, that indicated by the graph.

Note: Flow and return pipes should rise vertically on leaving the boiler.

Horizontal pipes should be ABOVE ceiling level and as SHORT as possible.

A MINIMUM inclination of 25mm per 3m run (1in. per 10ft), is required to avoid air locks.

If the above conditions cannot be met, pumped primaries should be used.

GUIDE TO MINIMUM REQUIREMENTS — FEED/EXPANSION TANK HEIGHT FOR FULLY PUMPED SYSTEMS — Fig. 8.

With reference to Fig. 8, the following assumptions and conditions apply:

1. Open vent and cold feed connections are made to the boiler flow/return tappings as shown.
2. The boiler is assumed to be the highest point of the circulating system.
3. The circulating pump is positioned on the FLOW, and

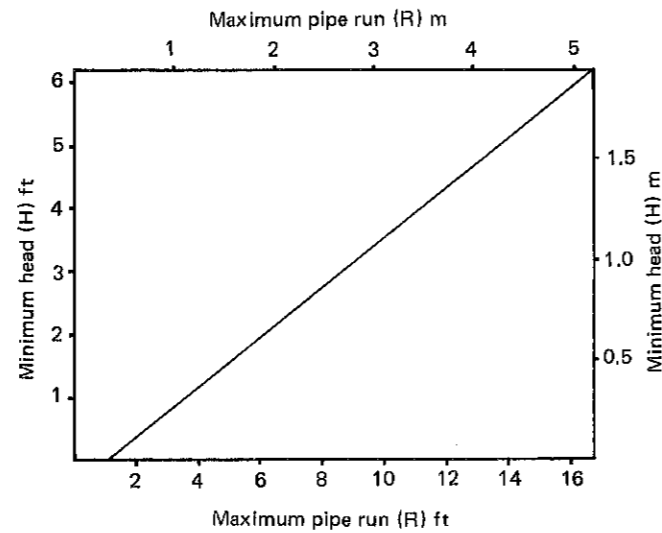
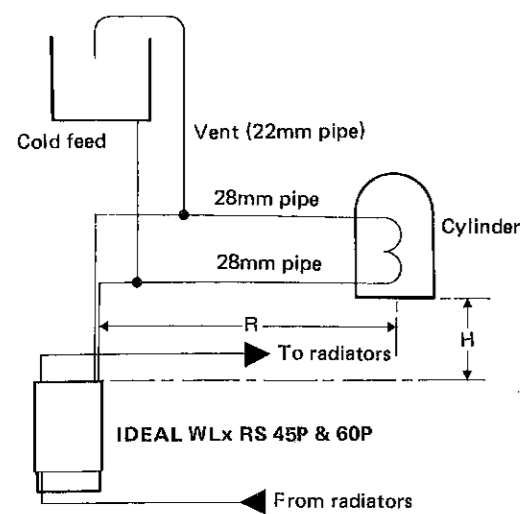

**SCHEMATIC PIPEWORK LAYOUT –
Combined Gravity Hot Water and
Pumped Heating**

Fig. 7

Dimensions in millimetres

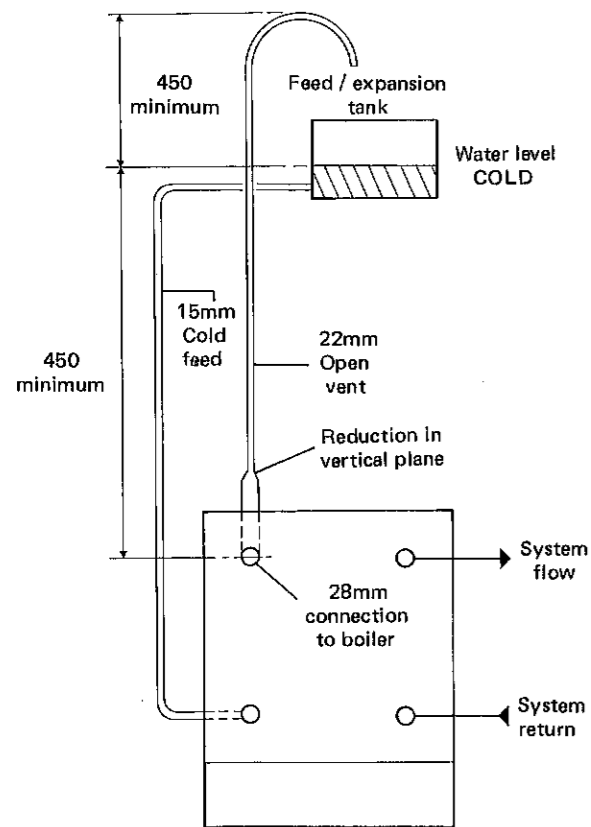

**FEED/EXPANSION TANK HEIGHT
FOR FULLY PUMPED SYSTEMS –
Guide to Minimum Requirements**

Fig. 8

the vertical distance, between the pump and the feed/expansion tank, complies with the Pump Manufacturer's minimum requirements – to avoid cavitation. Should these conditions not apply, either lower the pump position, or raise the feed/expansion tank above the minimum requirements of Stelrad Group.

- The water velocity through the boiler flow/return pipes is assumed to be below 1 m/s (3ft/s), whilst the pump flow rate is set to provide a temperature difference of 11°C (20°F) across the boiler flow/return, at design input.
- This information is intended as a GUIDE ONLY and cannot take into account instantaneous changes in head caused by the operation of motorised valves, pump, etc.

Due allowance MUST be made if surging is liable to occur. If in any doubt, contact Stelrad Group.

**FITTING FLUE DUCT ASSEMBLY AND
TERMINAL GRILLE – Fig. 9**

Separate the terminal grille (E) from the terminal duct assembly (C) by removing the two screws (F).

Smear the sealing compound, packed with the mounting plate, liberally on the INNER surface of the boiler air duct (A) and the OUTER surface of the terminal air duct (H).

Smear the end of each duct with a coat of sealing compound, 25mm (1in) wide, to ensure a good seal when mated together.

From OUTSIDE the building, pass the duct assembly (C) through the opening and slide it into the boiler outlet, ensuring that the flue duct (D) slides OVER the boiler flue outlet, and that the air duct (H) slides INTO the boiler air duct (A).

When correctly entered, push the terminal duct assembly (C) fully in, until the side fixing brackets (G) contact the wall face.

Make good between wall and ducts, inside AND outside the building.

When thoroughly dry, fasten the terminal grille (E) to the flue duct assembly (D) with the two screws (F).

EXTENSION DUCTS

Extension ducts are available for installation where wall thickness exceeds 406mm (16in). They are used to bridge the gap between the appliance terminal box and the flue duct assembly, and NO other method should be used. Neither should the gap be left unbridged.

Fitting the Extension Duct – Fig. 10

The extension duct has ends of unequal size, corresponding to the thickness of the metal. Take the larger duct and apply sealing compound liberally over 25mm (1in) of the OUTER surface of the SMALLER end.

Next, similarly, apply sealing compound to 25mm (1in) of the INNER surface of the boiler terminal air duct, – this is the OUTER duct.

Slide the SMALL end of the air duct extension through the

wall opening, and approximately 50mm (2in) into the boiler terminal air duct.

Slide the LARGE end of the flue duct extension OVER the boiler terminal flue duct, approximately 50mm (2in).

Apply sealing compound liberally to the first 25mm (1in) of the INNER surface of the air duct extension and the OUTER surface of the terminal duct assembly air duct.

Now fit the terminal duct assembly from OUTSIDE the building – the terminal grille MUST be removed by means of the screws (F).

Slide the flue duct OVER the extension flue duct, and the air duct INTO the extension air duct.

Push the terminal duct assembly inwards until the fixing brackets contact the wall surface.

Make good between wall and ducts inside AND outside the building.

When thoroughly dry, fasten the terminal grille (E) to the flue duct assembly (D) with the two screws (F).

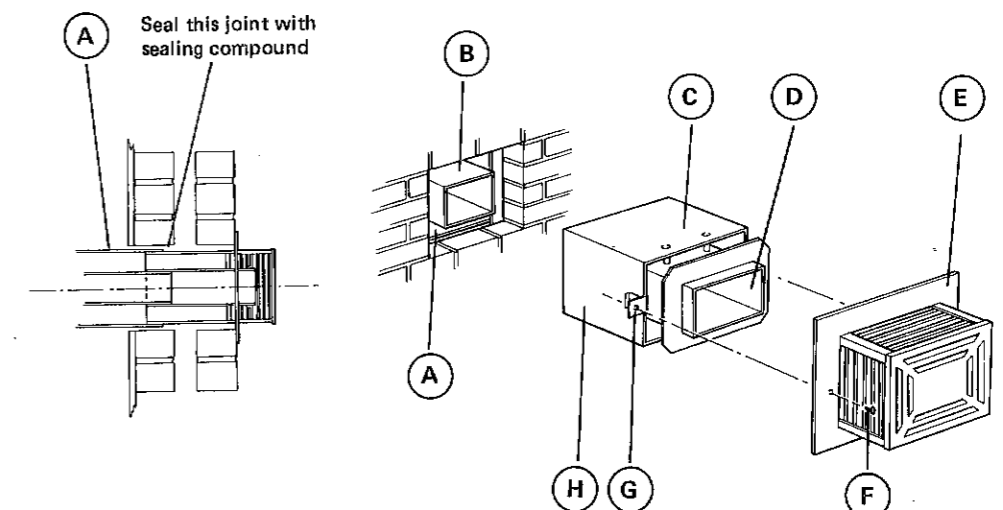

LEGEND

- | | |
|---------------------------|----------------------------------|
| A. Boiler Air Duct | E. Terminal Grille |
| B. Boiler Flue Outlet | F. Terminal Grille Fixing Screws |
| C. Terminal Duct Assembly | G. Side Fixing Bracket |
| D. Flue Duct | H. Air Duct |

Fig. 9

FLUE TERMINAL ASSEMBLY

Dimensions in mm (in)

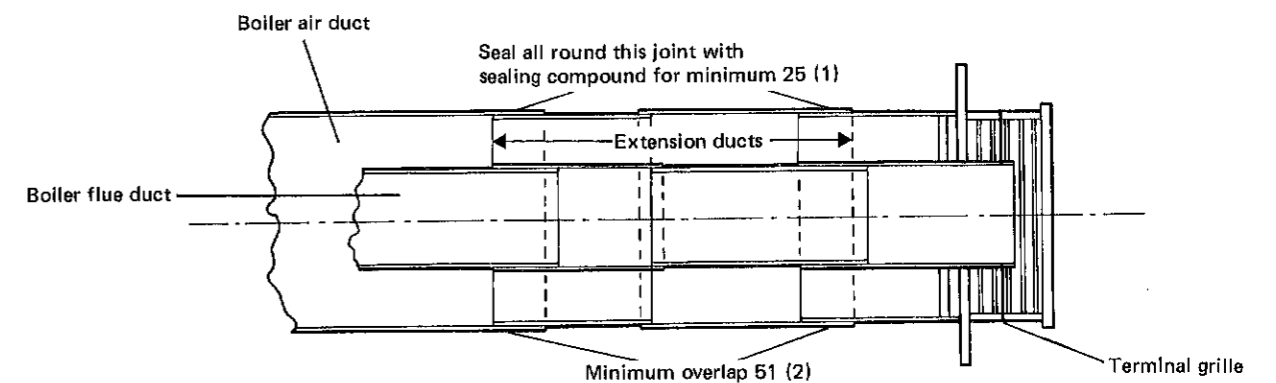

Fig. 10

**EXTENSION DUCT ARRANGEMENT
Used for wall thickness exceeding 406 (16)**

GAS CONNECTIONS

A MINIMUM gas pressure of 37 mbar (14.9in.w.g) MUST be available at the boiler inlet.

The main gas cock is on the left hand side of the control valve, below the boiler, and connection to the gas supply MUST be from the REAR of the boiler.

ELECTRICAL CONNECTIONS

WARNING: The appliance MUST be efficiently earthed.

A mains supply of 220/240 volt, 50 Hz, A.C., Single Phase, is required.

All external controls, and external wiring, MUST be suitable for mains voltage.

Wiring should be in three-core, PVC insulated cable, NOT less than 16/0.2mm.

Wiring external to the boiler MUST be in accordance with the I.E.E. Regulations, and any Local Regulations which apply.

The supply connection may be made via a removable plug to a shuttered socket-outlet and, should such a plug be used for connection to the mains, it MUST be of 3-pin type, wired as shown in Fig.11, fused at 3 amp, and complying with the requirements of BS.1363.

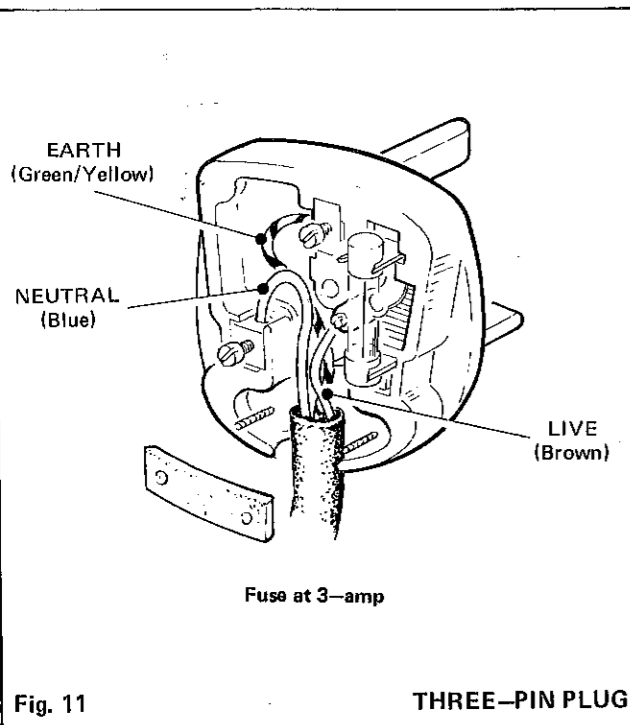

INTERNAL WIRING

The internal wiring of the control box is shown in Figs. 12 and 13.

A wiring diagram is also contained in the lighting instruction plate inside the control pad door.

A plug and socket connector is provided on the boiler control box for the mains supply.

EXTERNAL CONTROLS

The wiring diagrams illustrated in Figs. 14–21 cover the systems most likely to be fitted to this appliance.

For wiring external controls to the IDEAL WLx, RS boiler, reference should be made to the system wiring diagrams supplied by the relevant Manufacturer, in

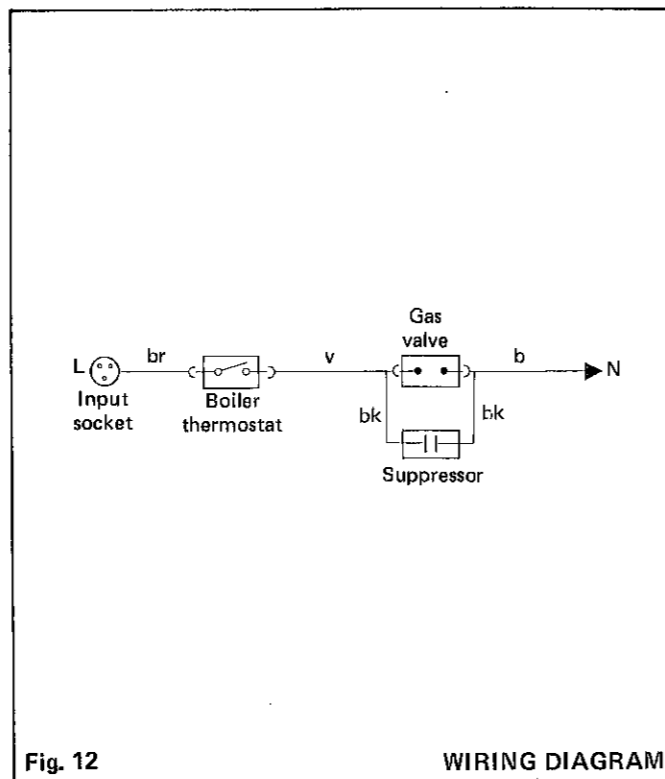

conjunction with the wiring diagrams shown in Figs. 12 and 13.

Difficulty in wiring should not arise, providing the following directions are observed:

1. Controls that switch the system ON and OFF, e.g. a time switch, MUST be wired, in series, in the live mains lead to the boiler.
2. Controls that over-ride an ON/OFF control, e.g. a frost thermostat, MUST be wired into the mains lead, in parallel, with the control(s) to be over-riden – refer Fig. 15.
3. Controls that switch the circulating pump only ON and OFF, e.g. a room thermostat, MUST be wired, in series, with the pump in the live pump lead.
4. If a proprietary system is used, follow the instructions supplied by the Manufacturers.
5. SYSTEM DESIGNS FEATURING CONTROLS OR WIRING ARRANGEMENTS, WHICH ALLOW THE BOILER TO FIRE WHEN THERE IS NO PUMPED OR GRAVITY CIRCULATION TAKING PLACE, **SHOULD NOT BE FITTED.**

Advice on required modifications to the wiring may be obtained from the component Manufacturers.

Note:

1. Connections between a frost thermostat and the time control should be made without disturbing other wiring.
2. A frost thermostat should be sited in a cool place in the house, but where it can sense heat from the system.

Wire the mains connector, supplied strapped to the control box, as follows:

Live (Brown)	to	L
Neutral (Blue)	to	N
Earth (Green/Yellow)	to	⊕

The connector may now be plugged into the control box.

Note: When the optional programmer kit is fitted, the incoming mains lead should be connected to the programmer input terminals, and the boiler control box three-pin plug wired in accordance with the

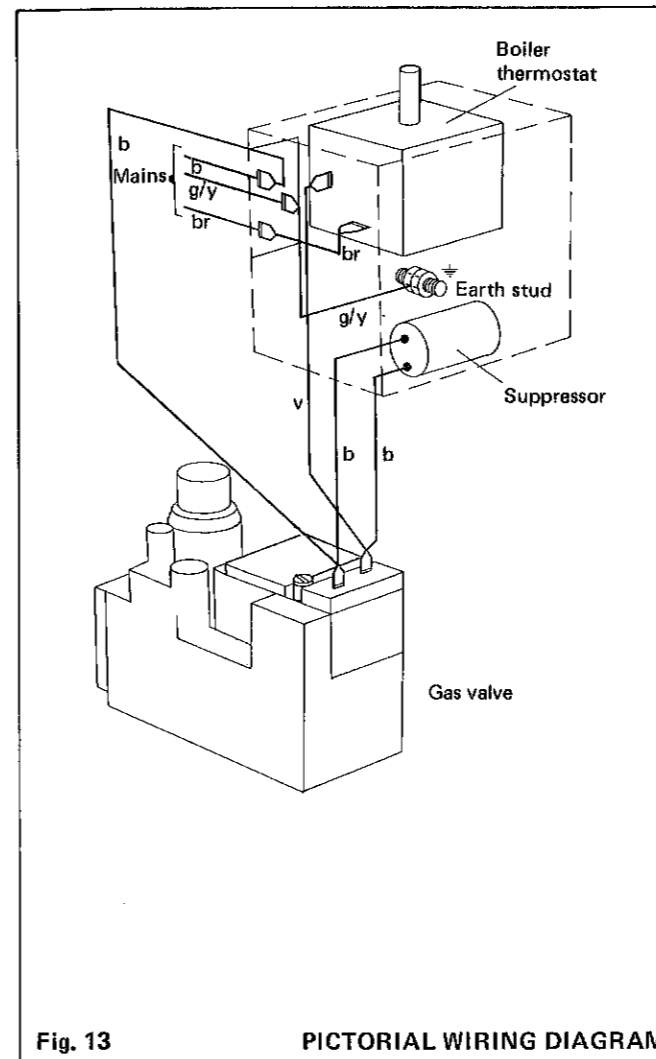

system diagrams shown in Figs. 2–9 inclusive – Programmer Installation Instructions.

FITTING THE CASING

WARNING: The boiler MUST NOT be operated with the casing removed.

Lift the boiler casing up to the boiler assembly and locate it on the rests on each side of the backplate. Push the casing so that the studs at each corner pass through the holes in the backplate.

Secure with the four wing nuts provided.

The casing MUST seat correctly on and compress the sealing strip to make an airtight joint.

Reconnect the earth bonding wire to the stud on the underside of the boiler casing.

Secure the terminal beneath the washer and nut.

This connection is IMPORTANT and MUST NEVER be omitted.

Locate the top of the controls pod in the runners on the underside of the boiler casing and slide the pod into position.

FITTING THE SIDE PLATES

Align the two slots in the side plate with the brackets behind the edge of the backplate and engage by pulling the plate forwards.

Note: The side plates are right and left handed.

COMMISSIONING AND TESTING

Electrical Installation

Checks to ensure electrical safety should be carried out by a competent person.

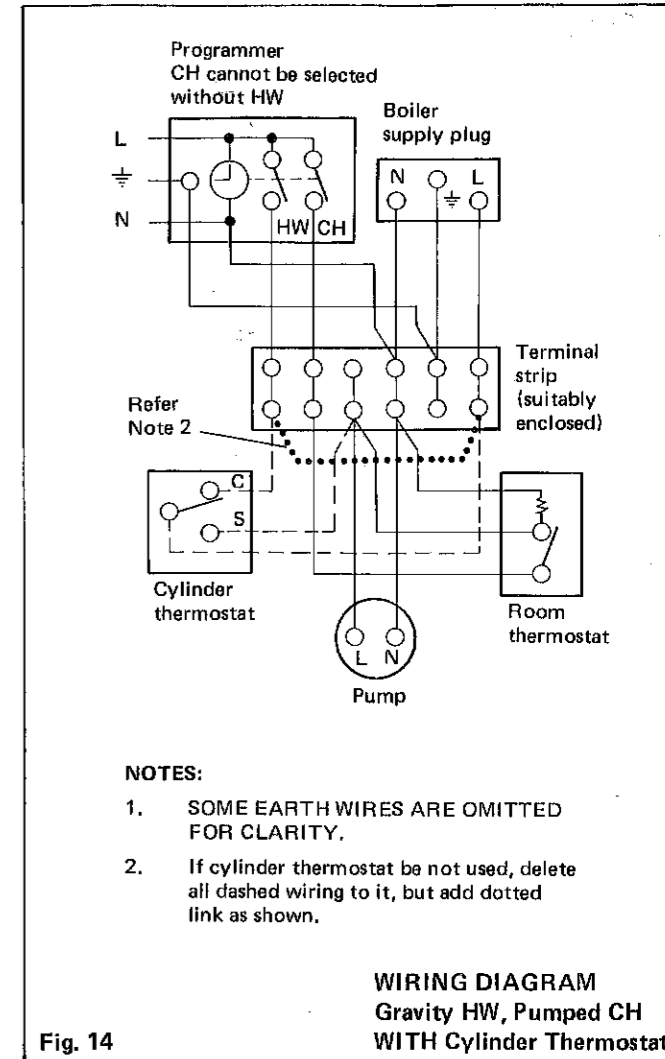

NOTES:

1. SOME EARTH WIRES ARE OMITTED FOR CLARITY.
2. If cylinder thermostat be not used, delete all dashed wiring to it, but add dotted link as shown.

FROST PROTECTION

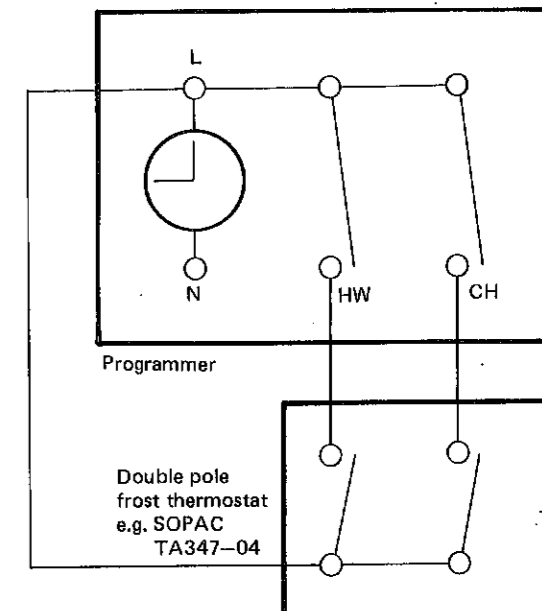

The frost thermostat should be wired to the programmer as shown, without disturbing other wiring.

without HW

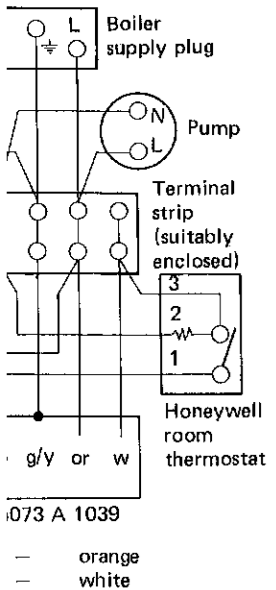

RES ARE OMITTED FOR
RE PROPER EARTH
WIRING.

inals on thermostats
Manufacturer mentioned.
rolled system — set the
to maximum.

**WIRING DIAGRAM —
Pumped Only System**

LANDIS & GYR LGM

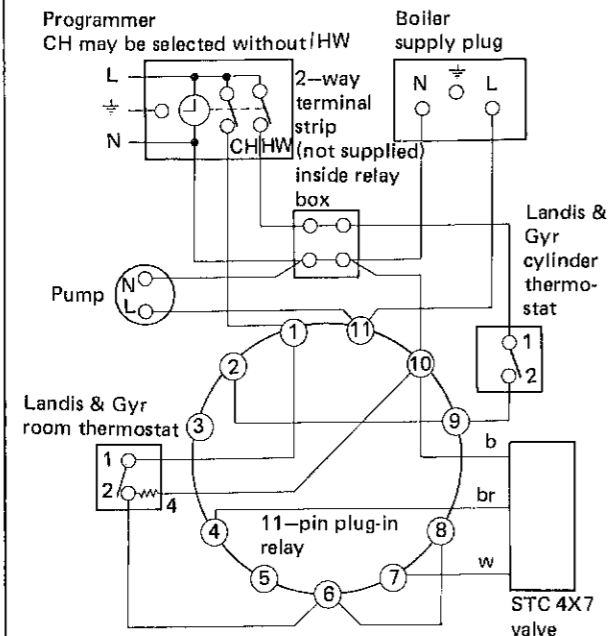

NOTES:

1. SOME EARTH WIRES ARE OMITTED FOR CLARITY. ENSURE PROPER EARTH CONTINUITY WHEN WIRING.
2. Numbering of terminals on thermostats applies only to the Manufacturer mentioned.
3. This is a fully controlled system — set the boiler thermostat to maximum.

LEGEND:
b — blue
br — brown
w — white

**WIRING DIAGRAM —
Pumped Only System**

Fig. 18

TWIN MOTORISED VALVES

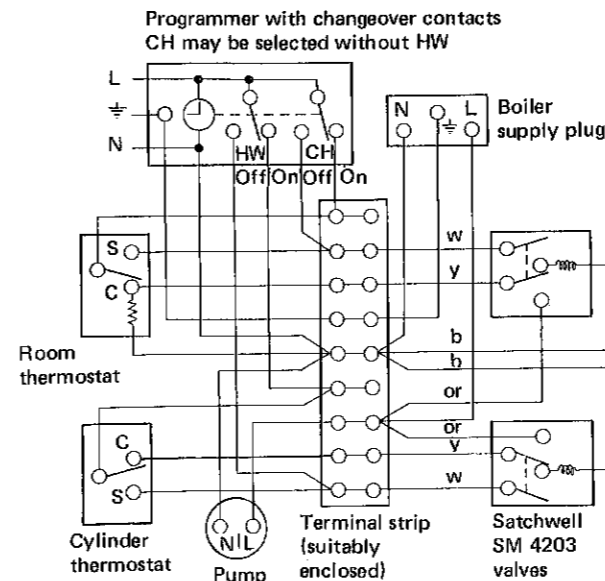

NOTES:

1. SOME EARTH WIRES ARE OMITTED FOR CLARITY. ENSURE PROPER EARTH CONTINUITY WHEN WIRING.
2. This is a fully controlled system — set the boiler thermostat to maximum.
3. Satchwell SM 4203 valves illustrated. Other makes may require auxiliary contacts to be separately energised.
4. Programmers with neons fitted — neons may light in error under certain circumstances with this system.

LEGEND:
w — white
y — yellow
b — blue
or — orange

**WIRING DIAGRAM —
Pumped Only System**

Fig. 20

Gas Installation

The whole of the gas installation, including the meter, if fitted, should be inspected and tested for soundness, and purged in accordance with the recommendations of BS.5482:1.

Purging air from the gas installation may be expedited by the removal of, or sliding forward, the controls pod, loosening the union on the inlet gas cock, and purging until gas is smelled.

Retighten the union and check for gas soundness.

WARNING:

Whilst effecting the required gas soundness test, and purging air from the gas installation, open all windows and doors, extinguish naked lights and **DO NOT SMOKE.**

Water Circulating System

The whole of the system should be thoroughly flushed out with cold water **WITHOUT** the pump in position.

Ensure that all valves are open.

With the pump fitted, the system should be filled and air locks cleared.

Check for water soundness.

INITIAL LIGHTING INSTRUCTIONS — Refer Fig. 22

Remove the controls pod.

The inlet gas cock **MUST** have been **OFF** for at least three minutes before initiating the lighting sequence.

Check that all drain cocks are **CLOSED**, and that stop valves in the flow and return lines are **OPEN**.

Check that the inlet gas cock (H) is **ON**, and that the boiler thermostat control knob is at **OFF**.

Loosen the screw in the burner pressure test nipple (E) and connect a gas pressure gauge via a flexible tube.

Turn the gas control knob (A) **CLOCKWISE** until resistance is felt and then release it. Wait for three minutes.

Push in the gas control knob (A), press, and release, the piezo unit button (G) repeatedly, until the pilot is seen to light through the sight glass.

Hold the gas control knob depressed for 20 seconds after the pilot burner has ignited.

Should the pilot light go out, at this, or any other stage, turn the gas control knob (A) **CLOCKWISE** and release it.

Wait for three minutes and then repeat the procedure detailed above, but wait longer than 20 seconds before releasing the gas control knob (A).

The pilot flame is factory set and should not be adjusted.

Check that the electricity supply, and all external controls, are **ON**.

Turn the boiler thermostat knob (C) to position 6, — the boiler will then light.

Operate the boiler for ten minutes to stabilise the burner temperature.

Test for gas leaks around the boiler gas components, using leak detection fluid.

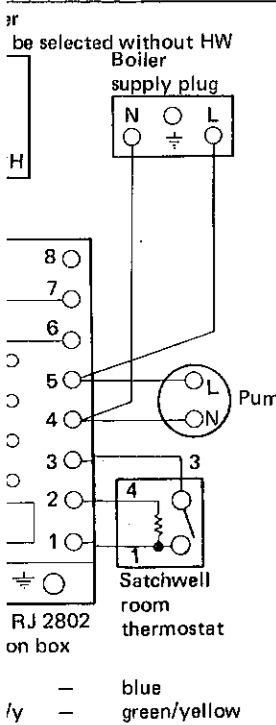

HONEYWELL 'C' PLAN

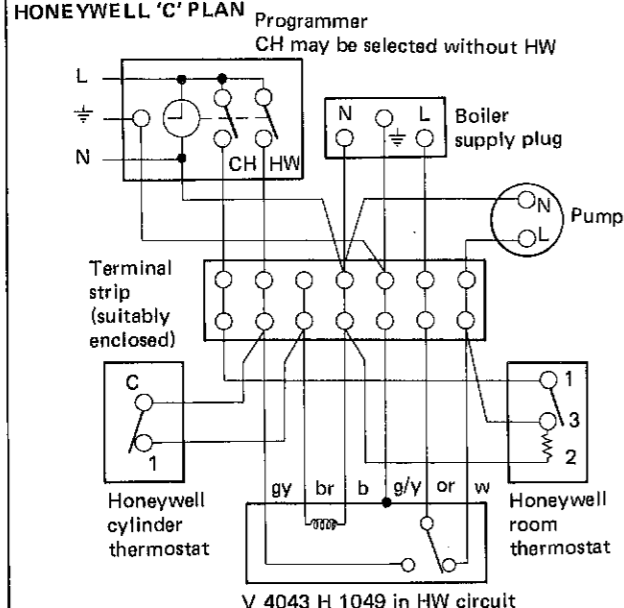

LEGEND:

gy — grey g/y — green/yellow
br — brown or — orange
b — blue w — white

NOTES:

1. SOME EARTH WIRES ARE OMITTED FOR CLARITY. ENSURE PROPER EARTH CONTINUITY WHEN WIRING.

TWO SPRING CLOSED VALVES

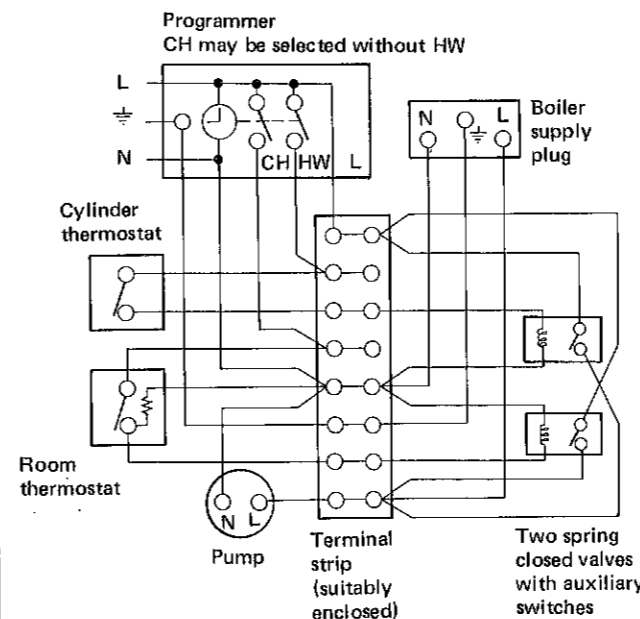

NOTES:

1. SOME EARTH WIRES ARE OMITTED FOR CLARITY. ENSURE PROPER EARTH CONTINUITY WHEN WIRING.

RES ARE OMITTED FOR
CLARITY.

Turn the boiler thermostat knob to OFF.

Remove the pressure gauge and tube, and retighten the sealing screw in the pressure test nipple.

Turn the boiler thermostat knob to position 6.

Check for gas leaks around the test nipple.

Replace the controls pod.

GENERAL CHECKS

Make the following checks for correct operation:

1. Turn the boiler thermostat OFF and ON, and check that the main burner is extinguished and relit in response.

2. Check the appearance of the pilot flame to ensure it envelops 13mm (½in) of the thermocouple tip. Refer – Pilot Burner Servicing.

3. Check the operation of the flame failure device in the gas control.

The flame failure device must cut off the gas to the burner within 60 seconds.

With the burner alight again, turn the gas control knob CLOCKWISE until resistance is felt, and then release it.

The burner and pilot flames should shut down immediately.

Note: A latch in the gas control provides a safe delay period before the boiler can be relit.

4. The correct operation of the programmer, and all other system controls, should be proved.

Operate each control separately, and check that the

main burner, or circulating pump, as the case may be, responds.

5. With the system HOT, examine all water connections for soundness. Then turn OFF the gas, electricity and water supplies to the appliance, and drain down whilst the system is still hot, in order to complete the flushing process.

Refill, and vent, the system, and again check for water soundness.

6. Finally, set the controls to the User's requirements.

The temperatures quoted below are approximate and vary between installations:

Knob Setting	Flow Temperature	
	°C	°F
1	54	130
2	60	140
3	66	150
4	71	160
5	77	170
6	82	180

HANDING OVER

After completion of installation and commissioning the system, the Installer should hand over to the Householder by the following actions:

1. Hand the User's Instructions publication to the Householder, and explain his/her responsibilities under the Gas Safety Regulations, 1972.
2. Draw attention to the Lighting Instruction Plate affixed

to the inside of the control pod door.

3. Explain, and demonstrate, the lighting and shutting down procedures.

4. The operation of the boiler and the use, and adjustment, of ALL system controls, should be fully explained to the Householder, to ensure the greatest possible fuel economy, consistent with household requirements of both heating and hot water consumption. Advise the User of the precautions necessary to prevent damage to the system, and to the building, in the event of the system remaining in-operative during frost conditions.

5. Explain the function, and the use, of the boiler thermostat and external controls.

SERVICING

WARNING:

ALWAYS turn OFF the gas supply at the gas cock, and switch OFF and DISCONNECT the electricity supply to the appliance BEFORE SERVICING.

A COMPREHENSIVE SERVICE SHOULD BE CARRIED OUT AT LEAST ONCE A YEAR.

THE USER IS ADVISED TO MAKE A CONTRACT WITH THE LOCAL PROPANE GAS SUPPLIER OR A QUALIFIED HEATING ENGINEER.

BURNER ASSEMBLY

Refer Figs. 23 & 24

Open the controls pod door, disconnect the earth bonding wire from the left hand side of the compartment, and disconnect the mains connector plug, located at the left hand side of the control box.

If a programmer is fitted, slide the control pod forward sufficiently to remove the two screws securing the plug connector to the left hand side of the programmer, and pull out the plug connector.

Remove the controls pod, complete with programmer, by sliding it forwards.

If the boiler is fitted with push-on side plates, remove these by pushing back to disengage from the retaining brackets.

Remove the four wing nuts, securing the boiler casing to the backplate, and remove the casing by pulling it forwards.

Unclip the boiler thermostat capillary from the backplate.

Remove the split pin securing the thermostat phial and withdraw the phial from its pocket.

Undo the union nut on the gas inlet cock.

Undo the two screws, securing the gas supply pipe sealing clamp to the backplate, and remove the clamp.

Support the burner and control assembly, and remove by unfastening the four nuts securing the burner to the backplate.

Remove to a convenient working surface for attention.

RS. 45P MODEL ONLY

Refer Fig. 23

Remove the right hand burner bracket.

Remove the two split pins securing the burner end cap, and remove the cap.

Withdraw the circular gauze (3) from the burner.

Clean the gauze to remove any deposits of lint, fluff, etc. and brush off any deposits that may have fallen on the burner head.

6. Explain, and demonstrate, the function of time and temperature controls, radiator valves, etc., in the economic use of the system.

7. Explain and demonstrate the cylinder changing procedure – See User's Instructions.

8. Stress the importance of regular servicing by a qualified Heating Engineer.

9. Draw attention to the User's Instructions Emergency Action Notice.

ALL MODELS

Ensure the flame ports are unobstructed, and remove any debris that may have collected.

Note: Brushes with metallic bristles must NOT be used.

Re-assemble in reverse order.

Inspect the pilot burner, thermocouple and ignition electrode; ensure that they are clean and in good condition.

In particular, check that:

1. The pilot burner is firmly secured.
2. The pilot shield is clean and unobstructed.
3. The ignition electrode and lead are clean, undamaged and secure.
4. The thermocouple tip is not burned or cracked.
5. The thermocouple terminal, at the gas valve, is clean and secure.

FLUEWAYS

Remove the complete burner assembly as previously described, and also the cleanout cover at the top of the boiler.

Remove the flueway baffles.

Remove all loose deposits from the heat exchanger, particularly from the flueways formed between the fins, using a suitable brush – available from Local Gas Regions, Ref. No. 4798 A, C and K.

Refit the flueway baffles.

Refit the cleanout cover, replacing any damaged, or deteriorating, sealing gasket.

Refit the burner assembly in reverse order of removal, and complete gas and electrical connections.

Check that the sight glass in the boiler casing is clean and undamaged.

Refit the boiler casing, controls pod and push-on side plates, if fitted, in reverse order of removal.

Note: Do NOT forget to reconnect the earth bonding wire to the earthing stud.

PILOT BURNER

Light the boiler and check that:

1. The pilot flame impinges on the thermocouple head, and that the position of the thermocouple, relative to the pilot burner and the main burner, is as shown in Figs. 25 or 26.
2. The pilot flame covers 13mm (½in) of the thermocouple tip.

The pilot adjuster screw is factory set to maximum and no further adjustment should be necessary.

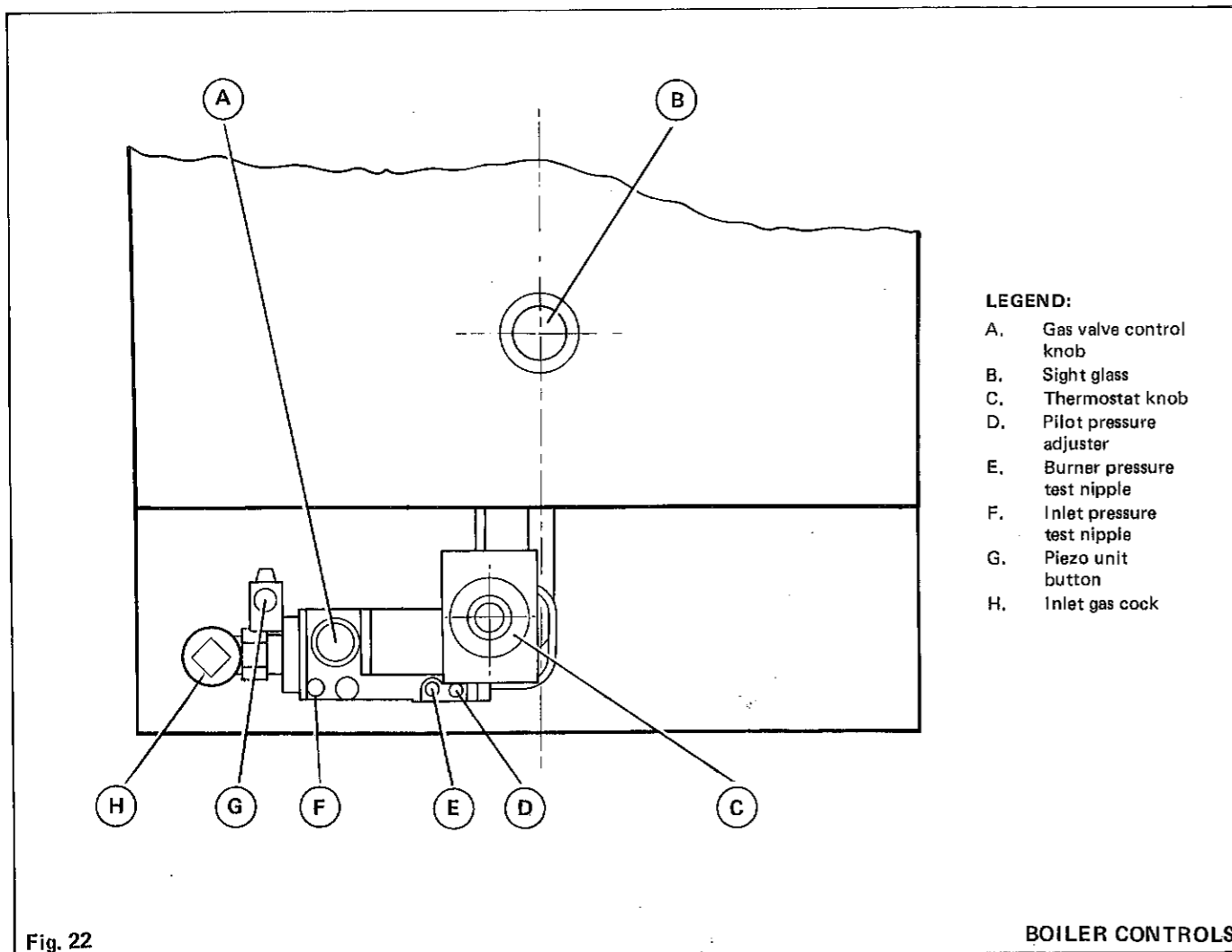

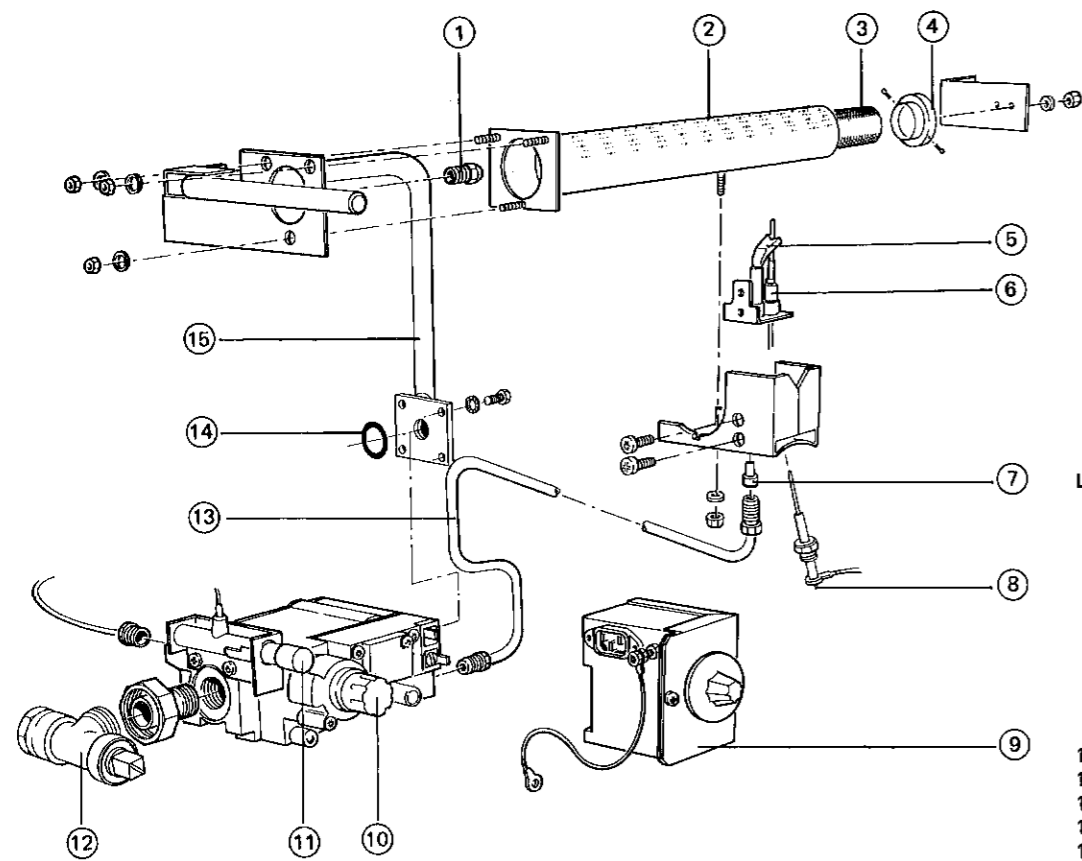

LEGEND:

1. Main Burner Injector
2. Burner Bar
3. Burner Gauze
4. Burner End Cap
5. Pilot Burner
6. Thermocouple
7. Pilot Injector
8. Spark Electrode
9. Control Box
10. Gas Control Knob
11. Piezo Unit
12. Inlet Gas Cock
13. Pilot Gas Pipe
14. 'O' Ring Seal
15. Gas Manifold

**BURNER AND CONTROL ASSEMBLY
IDEAL WLx RS. 45P MODEL**

Fig. 23

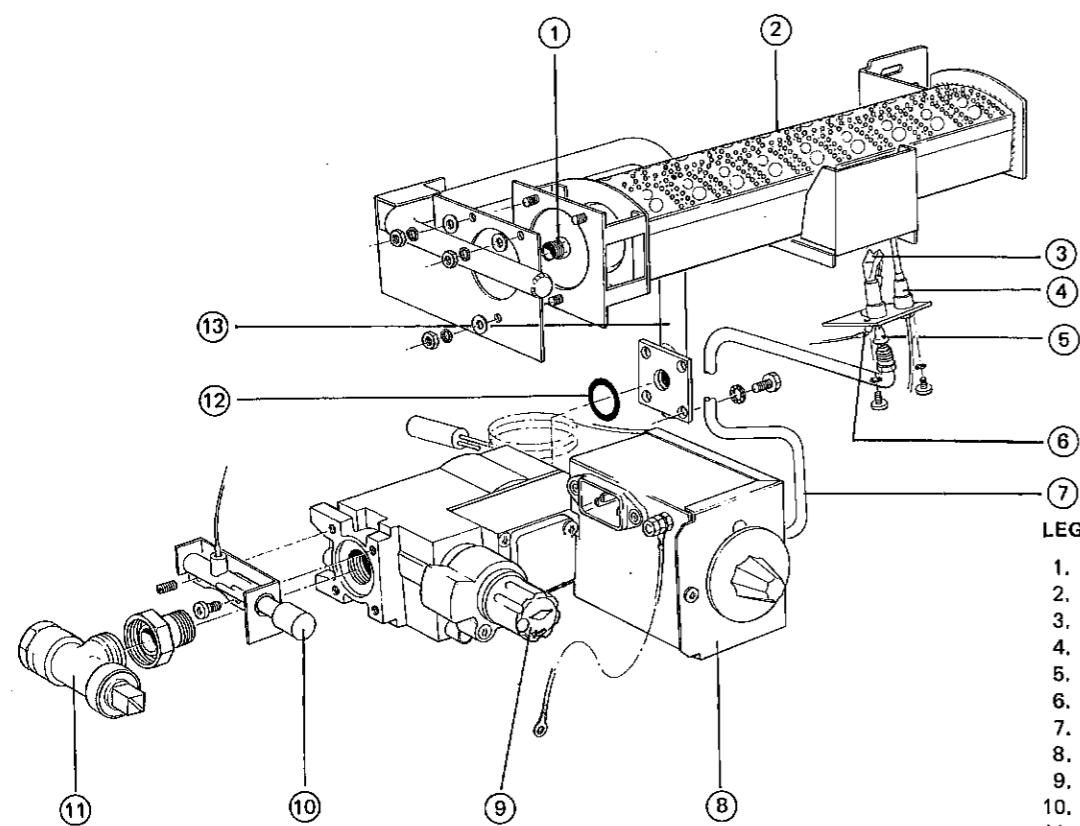

LEGEND:

1. Main Burner Injector
2. Burner Bar
3. Pilot Burner
4. Thermocouple
5. Pilot Injector
6. Spark Electrode
7. Pilot Gas Pipe
8. Control Box
9. Gas Control Knob
10. Piezo Unit
11. Inlet Gas Cock
12. 'O' Ring Seal
13. Gas Manifold

**BURNER AND CONTROL ASSEMBLY
IDEAL WLx RS. 60P MODEL**

Fig. 24

However, if the pilot flame appears small, check the adjustment of the pilot pressure adjuster screw (E), Fig. 22, as follows:

- (a) Turn the gas control knob (A), Fig. 22, **CLOCKWISE** until resistance is felt, and then release it.
- (b) Turn the pilot pressure adjuster screw **CLOCKWISE** until fully closed.
- (c) Turn the pilot pressure adjuster screw **ANTI-CLOCKWISE** four full turns to give maximum setting.
- (d) Relight the pilot in accordance with the lighting instructions.

Note: The pilot adjusting screw is sealed against User interference, and must be re-sealed if disturbed during servicing.

ADJUSTMENT OF GAS PRESSURE

After each occasion of servicing, reference should be made to Table 2, which quotes details of the rated output, with the related burner setting pressure and the heat input.

Any required adjustments can only be made external to the appliance.

REPLACEMENT OF COMPONENTS

WARNING:

ALWAYS turn OFF the gas supply at the inlet gas cock and switch OFF, and disconnect, the electricity supply, BEFORE WORKING on the appliance.

Note: To replace the following components, it will be necessary to remove the controls pod and the boiler casing, as previously described in the Servicing section of this publication.

Sight Glass

Unfasten the two nuts holding the sight glass assembly to the casing front panel.

When fitting the replacement assembly, make certain the parts are in correct order, i.e. gasket, glass, gasket and frame.

Note: The frame **MUST** have the return edge at the bottom.

Retighten the two nuts to ensure an airtight seal.

Do NOT overtighten.

Boiler Thermostat

Remove the electrical plug connection at the side of the control box.

Unclip the capillary from the backplate.

Remove the split pin and withdraw the phial from the pocket.

Undo the two screws, securing the gas supply pipe sealing clamp to the backplate, and remove the clamp.

Remove the screw on the front of the control box, and pull away the cover.

Pull off the two electrical connections from the thermostat head.

Pull off the thermostat knob.

Remove the thermostat capillary clip from the control box cover.

Undo the two screws holding the thermostat to the control box.

Fit the replacement thermostat and re-assemble in reverse order, ensuring that the electrical connections are at the bottom of the box – refer Fig. 27.

Piezo Unit

Unplug the igniter lead from the piezo unit body, remove the screw and shakeproof washer, securing the body to the

gas valve.

Fit new unit and reconnect the lead.

Igniter Lead

Unplug the igniter lead from the piezo unit body, and from the base of the electrode.

Undo the two screws securing the gas supply pipe sealing clamp to the backplate, and remove the clamp.

Remove the purse clip, securing the lead to the pilot supply pipe, and remove the lead.

Fit the new lead and re-assemble in reverse order.

Thermocouple

Undo the thermocouple connections at the pilot burner and gas valve.

Remove the purse clip from the pilot supply pipe.

Undo the two screws, securing the gas supply pipe sealing clamp to the backplate, and remove the clamp.

Fit the new thermocouple

Avoid sharp bends in the thermocouple lead, ensuring this follows the same route as previously.

Re-assemble in reverse order.

Pilot Burner

Remove the purse clip from the pilot supply pipe.

Undo the thermocouple and pilot pipe connections at the gas valve and at the pilot burner.

Do **NOT** lose the pilot injector, which is a push fit in the pilot pipe connection to the pilot burner.

Undo the two screws, securing the gas supply pipe sealing clamp to the backplate, and remove the clamp.

Pull off the igniter lead from the base of the electrode.

Undo the nut(s), securing the pilot bracket shield to the main burner, and remove the shield and pilot burner complete.

Undo the two screws securing the pilot burner to the pilot burner bracket.

The pilot burner can now be withdrawn.

Transfer the electrode to the new pilot burner –

RS. 60P Model ONLY

Fit the new pilot burner, ensuring that the pilot injector is in position when refitting the pilot pipe.

Re-assemble in reverse order.

Electrode

Remove the pilot burner assembly as previously described – **RS. 60P Model ONLY**

Disconnect the igniter lead from the electrode.

Unfasten the backnut, retaining the electrode, and withdraw from the pilot bracket.

Fit the new electrode.

Re-assemble in reverse order.

Control Box – Refer Fig. 27

Disconnect the electrical plug connection, and earth connection, located at the left hand side of the control box.

Undo the two screws, securing the gas supply sealing clamp to the backplate, and remove the clamp.

Unclip the thermostat capillary from the backplate.

Remove the split pin and withdraw the phial from the thermostat pocket.

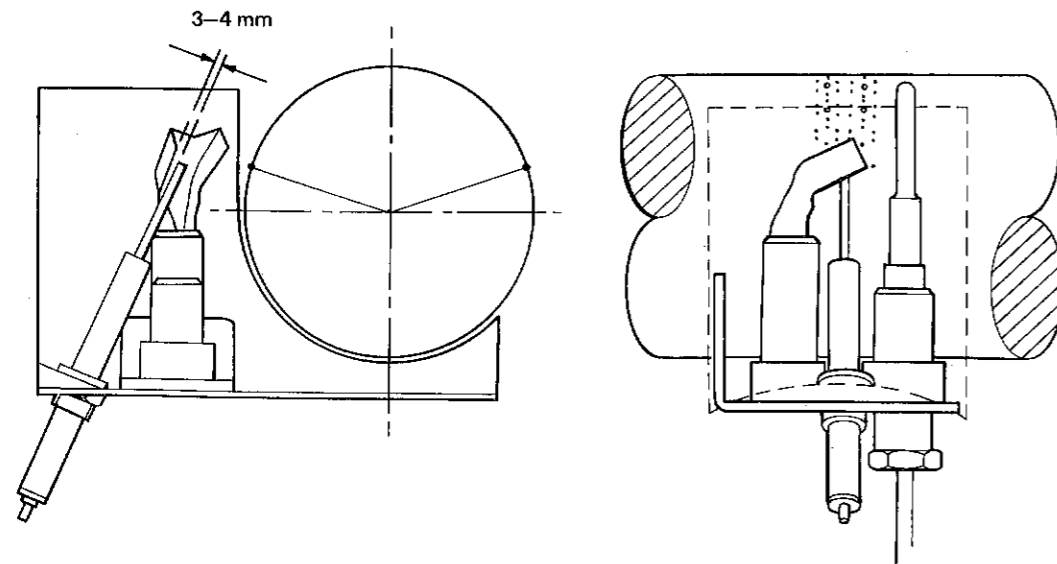

Fig. 25

PILOT AND ELECTRODE POSITION
IDEAL WLx RS. 45P MODEL

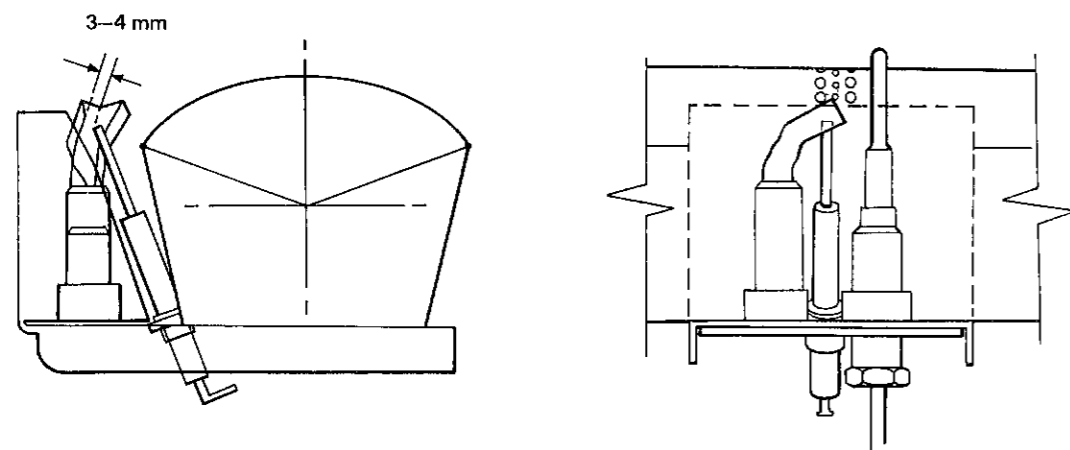

Fig. 26

PILOT AND ELECTRODE POSITION
IDEAL WLx RS. 60P MODEL

Undo the screw on the front of the control box, and withdraw the control box cover.

Disconnect the leads from the gas valve.

Undo the screw securing the control box body to the gas valve and withdraw the box.

Fit the new control box, re-assembling in reverse order.

MAIN BURNER and GAS VALVE

Refer Figs. 23 & 24

Remove the burner and controls assembly as previously described in Servicing Instructions.

Main Burner

Undo the nut(s) securing the pilot bracket to the main burner, and pull the bracket clear of the burner.

Undo the three nuts securing the left hand end of the burner to the gas manifold.

The burner can now be pulled clear.

Undo the nut at the right hand end of the burner, securing the burner bracket, and remove the bracket — RS.445P Model ONLY.

Fit the new burner in reverse order, being careful not to damage the main burner injector which is screwed into the gas manifold.

Gas Valve

Remove the control box as previously described.

Remove the piezo unit, and transfer the locating grub screw from the old gas valve to the new valve.

Undo the pilot pipe and thermocouple connections at the gas valve.

Unscrew the gas cock union at the left hand side of the gas valve.

Unfasten the four screws securing the gas valve outlet pipe.

The sealing 'O' ring should be discarded and a new one fitted.

Re-assemble in reverse order, ensuring that:

- (a) the new gas valve is fitted the right way round — an arrow, engraved on the valve, indicates the direction of flow; and
- (b) the sealing 'O' ring is fitted correctly between the flanges on the end of the gas pipe and the gas valve.

Refit the burner assembly in reverse order of removal, complete gas and electrical connections, refit the casing and test for gas soundness.

IMPORTANT

Use an approved jointing compound when replacing the main burner injector or service cock.

CABINET SEALS

Remove the boiler casing and control pod as previously described.

Remove the old seals from the top and sides of the backplate.

Clean away any traces of the old adhesive, etc.

Peel off the backing from the new sealing strip, and adhere to the sides and top of the backplate.

The top strip should overlap the side strips at the top corners.

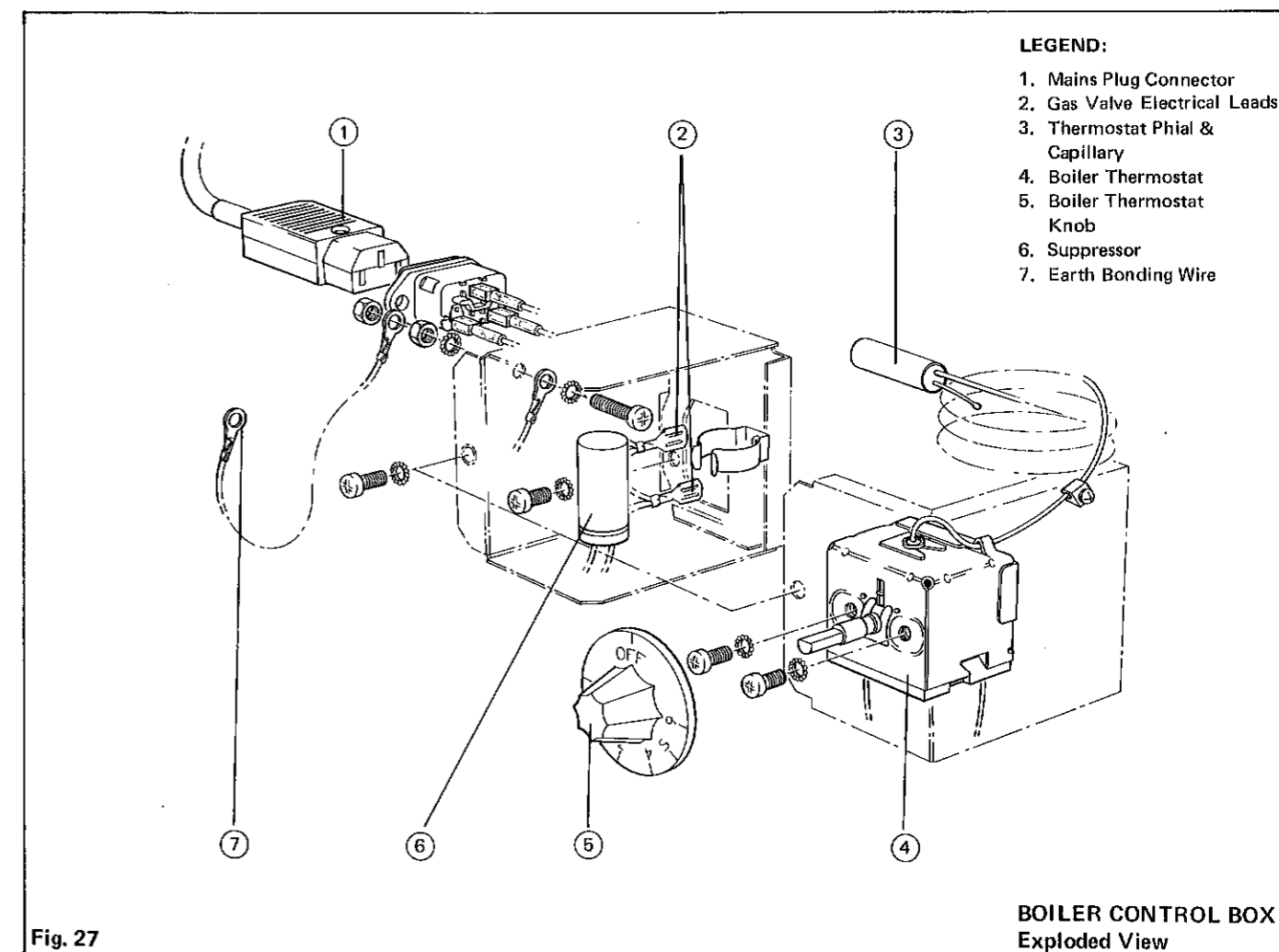

Fig. 27

BOILER CONTROL BOX
Exploded View

Avoid stretching the sealing strip, and ensure a good bond by pressing down firmly.

Remove the old sealing strip from the bottom of the boiler casing, and fit new sealing strip.

PIPE SEALING BLOCKS

To replace pipe sealing blocks, it will be necessary to unfasten the union at the gas supply cock, — ENSURE that the cock is in the OFF position.

Remove the burner and controls assembly as previously described in Servicing Instructions.

Remove the sealing blocks in the pipe clamp and the backplate bracket.

Fit new blocks.

Re-assemble in reverse order.

IMPORTANT:

After working on the appliance, NEVER FORGET to reconnect the earth bonding wire to the earthing stud on the boiler casing.

FAULT FINDING

Before attempting any electrical fault finding; ALWAYS carry out the preliminary electrical system checks as detailed on pages 6—9 of the Instructions for the British Gas Multimeter.

Detailed instructions on the replacement of faulty components are contained in the Servicing section of this publication.

PILOT WILL NOT LIGHT

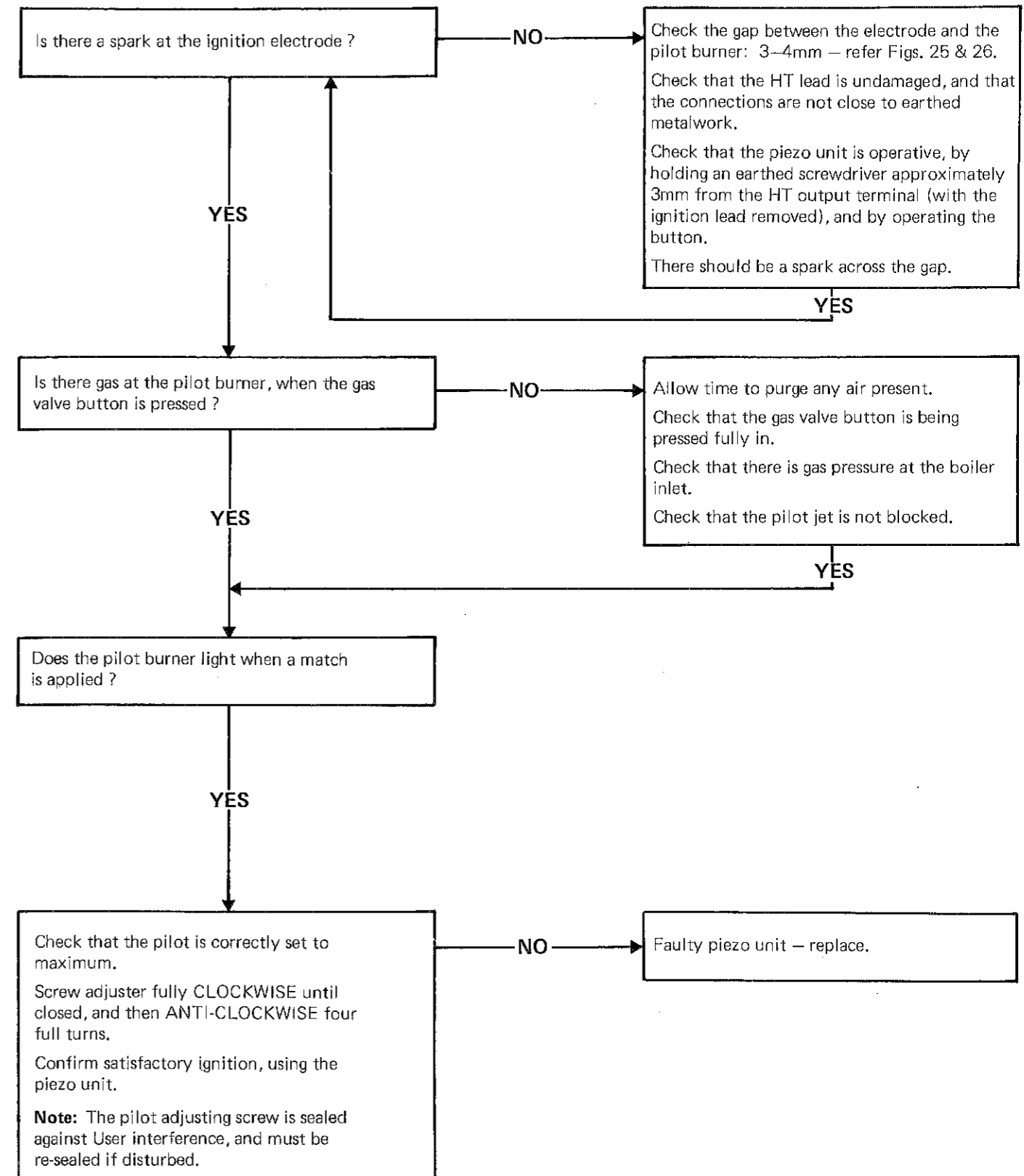

PILOT WILL NOT STAY LIT WHEN THE GAS VALVE BUTTON IS RELEASED

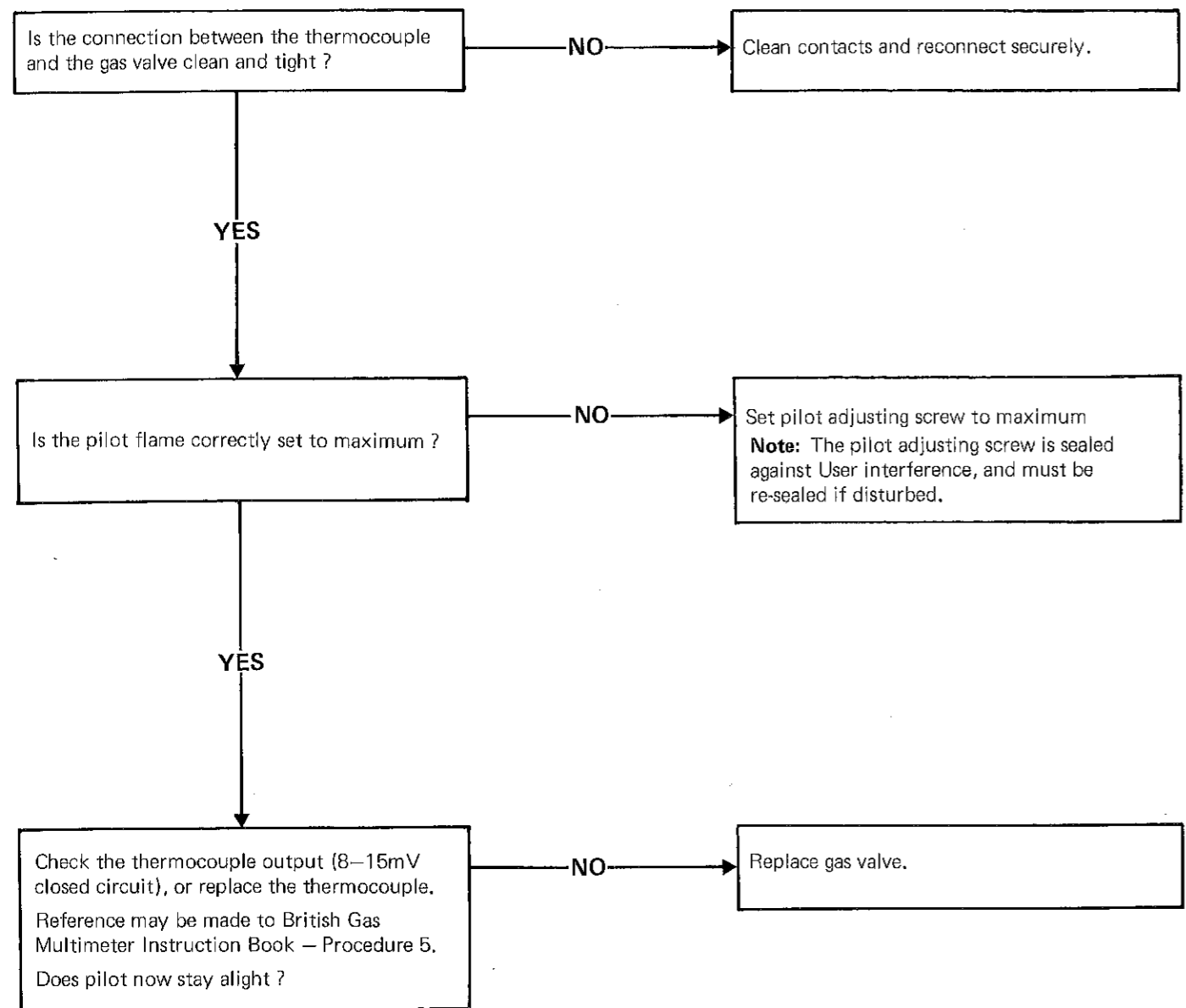

PILOT LIT, BUT NO MAINS GAS

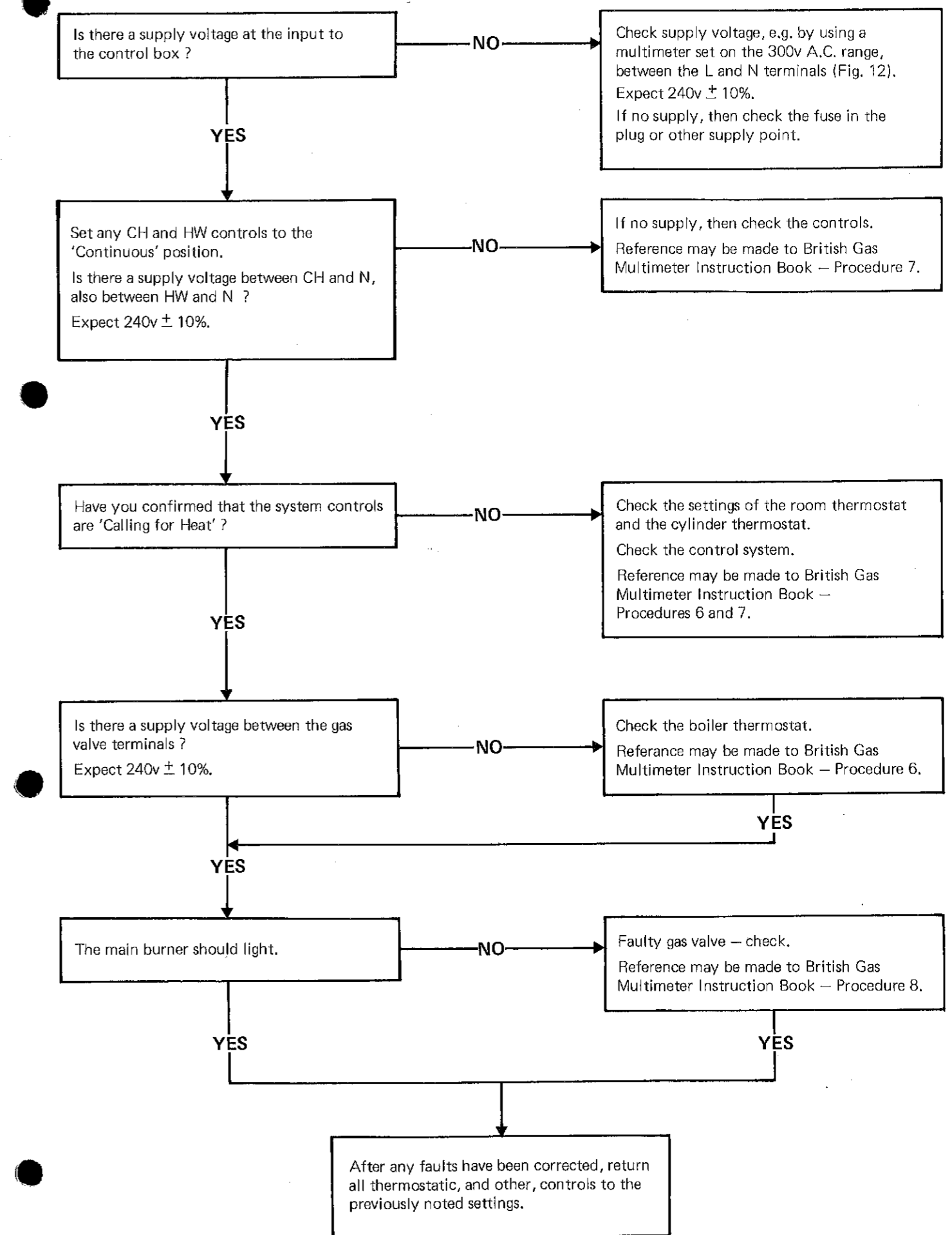

SHORT LIST OF PARTS

The following list comprises parts commonly required as replacements due to damage, expendability, or such that their failure, or absence, is likely to affect safety or performance.

IDEAL ELITE RS. 45P GAS BOILER

When ordering spares, please quote:

1. Boiler Model
2. Description
3. Maker's Part Number
4. Quantity

Key No.	B.G.C. Part No.	Description	No. Off	Maker's Part No.
7		Sight glass assembly, comprising: sight glass and frame, 2—sight glass gaskets, 2 x M4 hex nuts and 2 x M4 shakeproof washers	1	189648175
10		Main burner — BRAY Mk.9 No.AB 16637 — RS.430	1	189334084
		Main burner — BRAY Mk.9 No.AB 16638LR —RS.440 & RS.450	1	189344084
11		Lint arresting gauze	1	
12		Main burner injector — BRAY Cat. 10 Size 520	1	189445060
13		Pilot burner injector — HONEYWELL 45000062/012	1	189460083
14		Pilot burner — HONEYWELL Q359 A 1017 with injector Key No. 13	1	589460084
16		1/2in.BSP HONEYWELL Compact gas control V4600 A1023—240v with regulator removed.	1	589460049
18		Piezo unit — VERNITRON 60038, with RH outlet	1	589040086
19		Ignition electrode and H/T lead assembly (H/T lead 460mm lg.)	1	589030089
20		Thermocouple — HONEYWELL Q309A 2739 — 24in. lg.	1	576890051
22		Control box, including Key No's 23, 24 & 26	1	589040065
23		Thermostat — RANCO CL6 P0105, with 48in. capillary	1	589040051
24		Thermostat knob — RANCO 83151—31	1	589020051
27		Mains connector — ASHLEY or BULGIN to CEE 22 sheet 5 and BS.4491	1	589030015
28		Boiler casing assembly, White Stove Enamel, with sight glass trim, bottom sealing strip, dimple foil insulation, earthing point and 4 x M5 wing nuts — includes Key No. 7	1	189534030
28A		Smoked brown glass fascia	1	
29		Controls casing (less door), brown, with 2—hinges and door clip	1	
30		Controls casing door, brown stove enamel, with name badge, and Lighting Instructions	1	
31		R.H. push-on side plate	1	
32		L.H. push-on side plate	1	
33	341 303	Sealing pack, comprising: 2 sealing strips — 485mm lg., 2—sealing strips — 585mm lg., 1—pair sealing blocks, pipe sealing clamp and 2 x M5 x 45mm lg. csk hd. screws	1	189534033

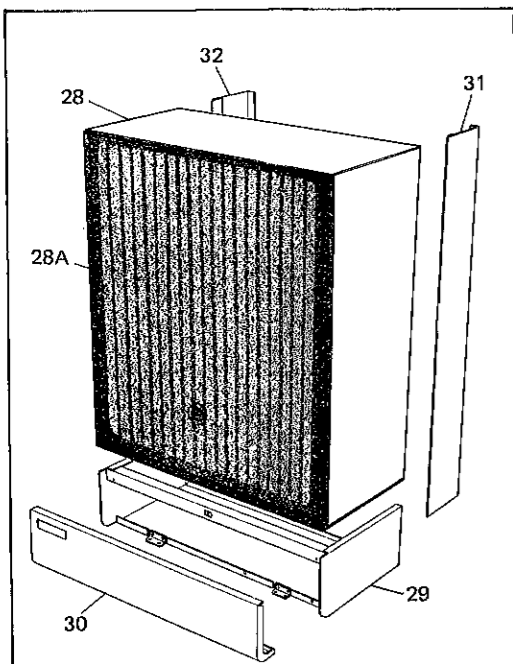

Fig. 28

CASING
EXPLODED VIEW

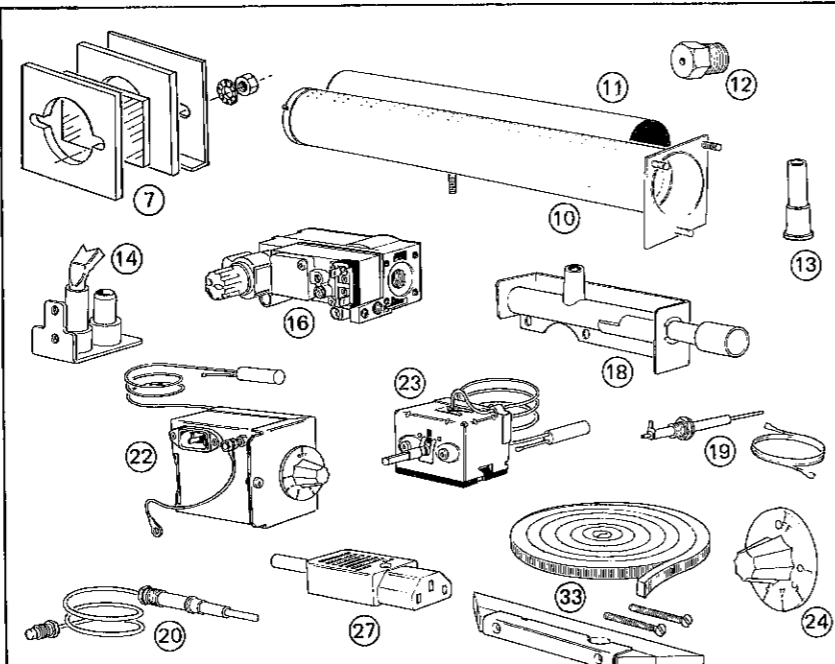

Fig. 29

SMALL PARTS

SHORT LIST OF PARTS

The following list comprises parts commonly required as replacements due to damage, expendability, or such that their failure, or absence, is likely to affect safety or performance.

IDEAL WLx RS. 60P GAS BOILER

When ordering spares, please quote:

1. Boiler Model
2. Description
3. Maker's Part Number
4. Quantity

Key No.	B.G.C. Part No.	Description	No. Off	Maker's Part No.
7		Sight glass assembly, comprising: sight glass and frame, 2—sight glass gaskets, 2 x M4 hex nuts and 2 x M4 shakeproof washers	1	189648175
10		Main burner — AEROMATIC 19/123213 + tubular baffle	1	189460076
12		Main burner injector, — Bray Cat. 10 Size 650	1	189460060
13		Pilot burner injector — HONEYWELL 45000062/012	1	189460083
14		Pilot burner — HONEYWELL Q359A1041 with injector key No.13	1	589460084
16		1/2in.BSP HONEYWELL Compact gas control V4600 A1023—240v with regulator removed.	1	589460049
18		Piezo unit — VERNITRON 60038, with RH outlet	1	589040086
19		Ignition electrode — KIGASS — and H/T lead assembly (H/T lead 460mm lg.)	1	589030088
20		Thermocouple — HONEYWELL Q309A 2739 — 24in. lg.	1	576890051
22		Control box, including Key No's 23, 24 & 26	1	589040065
23		Thermostat — RANCO CL6 P0105, with 48in. capillary	1	589040051
24		Thermostat knob — RANCO 83151—31	1	589020051
27		Mains connector — ASHLEY or BULGIN to CEE 22 sheet 5 and BS.4491	1	589030015
28		Boiler casing assembly, White Stove Enamel, with sight glass trim, bottom sealing strip, dimple foil insulation, earthing point and 4 x M5 wing nuts — includes Key No. 7	1	189534030
28A		Smoked brown glass fascia	1	
29		Controls casing (less door), brown, with 2—hinges and door clips	1	
30		Controls casing door, brown stove enamel, with name badge, and Lighting Instructions	1	
31		R.H. push-on side plate	1	
32		L.H. push-on side plate	1	
33	341 303	Sealing pack, comprising: 2— sealing strips — 485mm lg., 2—sealing strips — 585mm lg., 1—pair sealing blocks, pipe sealing clamps and 2 x M5 x 45mm lg., csk hd. screws	1	189534033

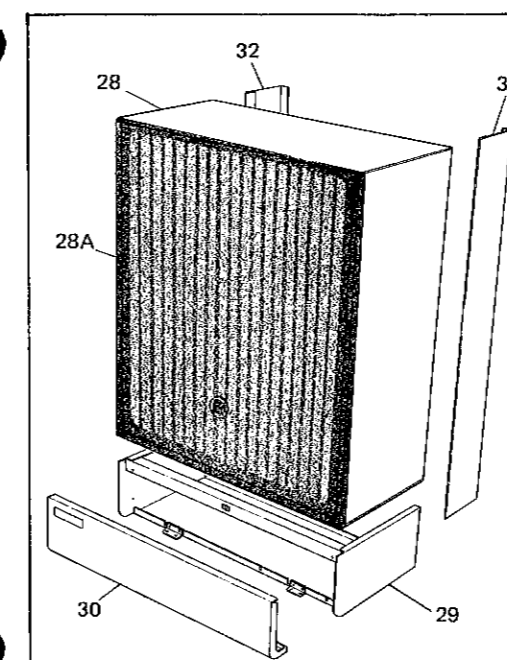

Fig. 30

CASING —
EXPLODED VIEW

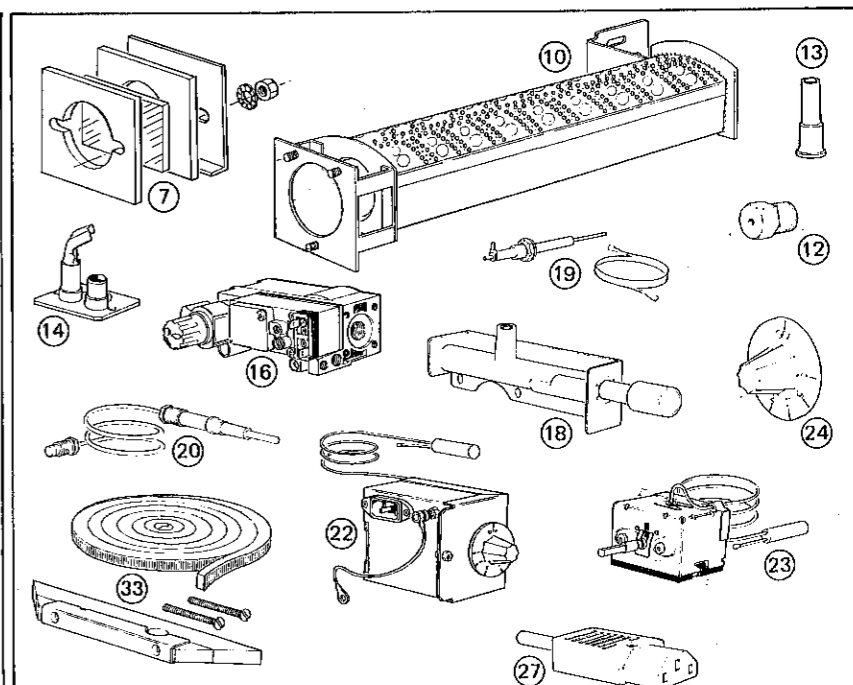

Fig. 31

SMALL PARTS

STELRAD GROUP pursues a policy of continuing improvement in design and performance of its products. The right is therefore, reserved to vary specification without notice.

STELRAD GROUP Limited

Sales and Marketing
P.O. Box 103, National Avenue
Kingston upon Hull.
North Humberside. HU5 4JN

Telephone: 0482 492251 Telex: 527032

Head and Registered Office:

Newtown Road, Henley-on-Thames. Oxfordshire RG9 1HL

Registration No. London 322137

A SUBSIDIARY OF METAL BOX p.l.c.

H.0453 (1) 7/85

Printed in England.

 **STELRAD
GROUP**