

POTTERTON

SV25

KINGFISHER II

open flue gas fired boilers

Potterton Kingfisher II, CF.80
20.5 to 23.4 kW (70,000 to 80,000 Btu/h) Output

Potterton Kingfisher II, CF.100
23.4 to 29.3 kW (80,000 to 100,000 Btu/h) Output

IMPORTANT

This appliance is for use with Natural Gas only. It must be installed by a competent person as stated in the Gas Safety (Installation and Use) Regulations 1984.

Leave these instructions adjacent to the gas meter.

- * Highly efficient, designed especially for natural gas operation.
- * Pipework can be run behind the boiler within its casing, from one side to the other, to suit particular site requirements.
- * No by-pass pipework required in the system.
- * A circulating pump can be mounted within the case (optional extra in kit form).
- * Can be installed beneath standard height working surfaces. (CF.80 only).
- * Piezo electric push button ignition for easy lighting.

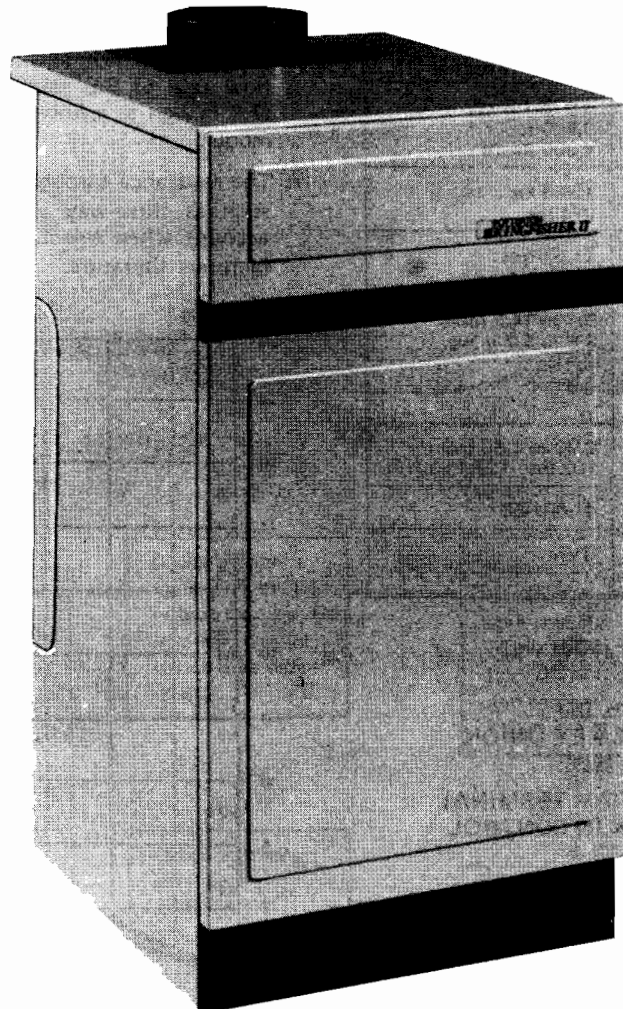

INSTALLATION AND SERVICING INSTRUCTIONS

DATA SECTION

GENERAL

These Potterton open flued appliances are automatically controlled and have been designed for combined systems, e.g. small bore or microbore central heating with an indirect domestic hot water supply which can either have pumped or gravity circulation. The boilers can also be used on pumped central heating or domestic hot water only systems.

DESCRIPTION — See Figs. 2 and 3

Potterton Kingfisher II boilers can be installed either in a kitchen or utility room or inside a suitably ventilated, purpose designed or modified compartment. The boilers are enclosed in white, stove enamelled, sheet steel casings, which conform in height with other kitchen furniture. A pump kit is available as an optional extra and can be supplied by the local distributor and fitted inside the boiler casing.

If the CF80 is required to fit flush with the top of 900 mm units, then an optional extra top panel is available.

GENERAL DATA — TABLE 1

	CF80	CF100
Input	27.4 to 30.8 kW 93,300 to 105,000 Btu/h	31.2 to 38.6 kW 106,600 to 131,600 Btu/h
Output into Water	20.5 to 23.4 kW 70,000 to 80,000 Btu/h	23.4 to 29.3 kW 80,000 to 100,000 Btu/h
Output into Air (approx)	0.8 to 1.0 kW 2,900 to 3,300 Btu/h	1.0 to 1.3 kW 3,500 to 4,300 Btu/h
Weight, Empty	102 kg 224 lbs	124.4 kg 274 lbs
Water Content	9.3 litres 16.4 pints	11.5 litres 20.2 pints
Burner Pressure	12.4 to 15.5 mbar 5.0 to 6.2 in.w.g.	9.4 to 14.2 mbar 3.8 to 5.7 in.w.g.
Injector Size/Marking	3.1 mm	2.9 mm
Gas Rate (1035 Btu/cu.ft.)	2.56 to 2.87 cu.m/h 90.1 to 101.4 cu.ft/h	2.92 to 3.60 cu.m/h 102.9 to 127.1 cu.ft/h
G.C. No.	41-601-82	41-601-83
Potterton Code Letters	GVM	GVN

MAXIMUM WORKING HEAD	: 2.7 bar (90 ft.wg.)
GAS CONNECTION	: TO ½ in. BSP LOOSE KEY UNION COCK, Rc½
ELECTRICAL CONNECTION	: TO 3-WAY TERMINAL BLOCK IN CONTROL BOX
COMBINATION GAS CONTROL	: S.I.T. 0.820.010
THERMOSTAT	: RANCO CL6
PILOT BURNER	: S.I.T. 0.140.012
MAIN BURNER	: CF80—FURIGAS (2 OFF) CF100—FURIGAS (3 OFF)

THE SYSTEM — See Figs. 6 to 10

The boilers can be installed in most types of system but the following notes are given as a general guide. The general recommendations given in BS.5376 Part 2 and BS.5449 Part 1 should be observed.

These boilers are not suitable for sealed systems.

1. All systems should be designed so that the static head at the boiler is between a minimum of 90 mbar (3 ft.wg.) and a maximum of 2.7 bar (90 ft.wg.).
2. If the head is at or near the 90 mbar (3 ft.wg.) minimum, extra care should be taken when designing the system to ensure that pumping over or ingress or air down the vent pipe cannot occur.
3. All gravity systems should have a minimum effective head of 1.2 m (4 ft.) between the centre line of the boiler heat exchanger and the centre line of the domestic hot water cylinder.
4. Most types of system controls, such as two-way valves, three-way valves, diverter valves, twin pumps, zone valves and room, cylinder and frost thermostats can be used in conjunction with these boilers.
5. An indirect domestic hot water cylinder should be used, incorporating a coil type of heat exchanger. In a fully pumped system, the primary pipework should include a lockshield valve.
6. The circulating pump should be selected with reference to Fig. 1. The resistance through the boiler heat exchanger will not exceed 10.5 mbar (4.2 in.wg.) at a flow rate of 6.6 gal/min. on the CF80 or 19.0 mbar (7.6 in.wg.) at a flow rate of 8.3 gal/min. on the CF100 model.
7. The resistance through any other type of system control such as three-way valves, should also be taken into account when selecting a pump; refer to their manufacturers literature.

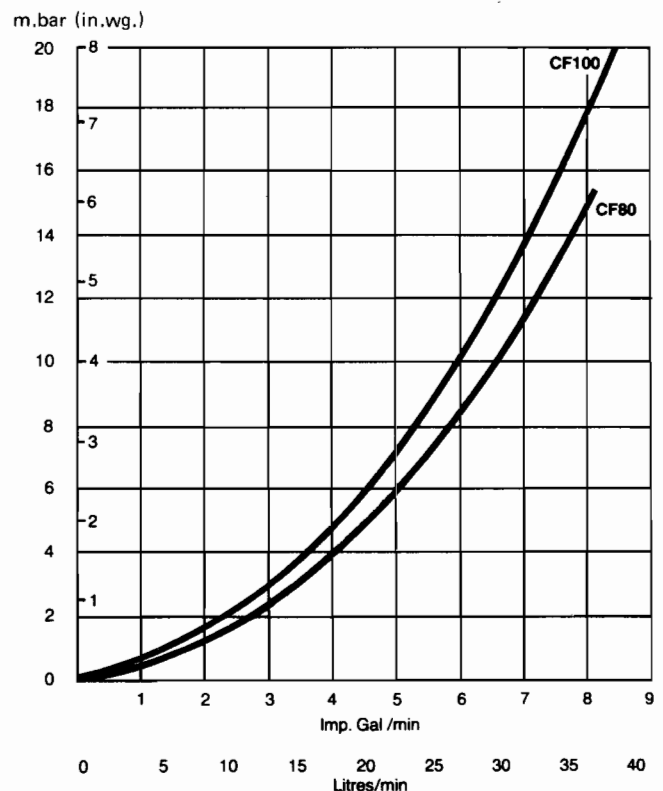

FIG. 1 PRESSURE LOSS ACROSS BOILER

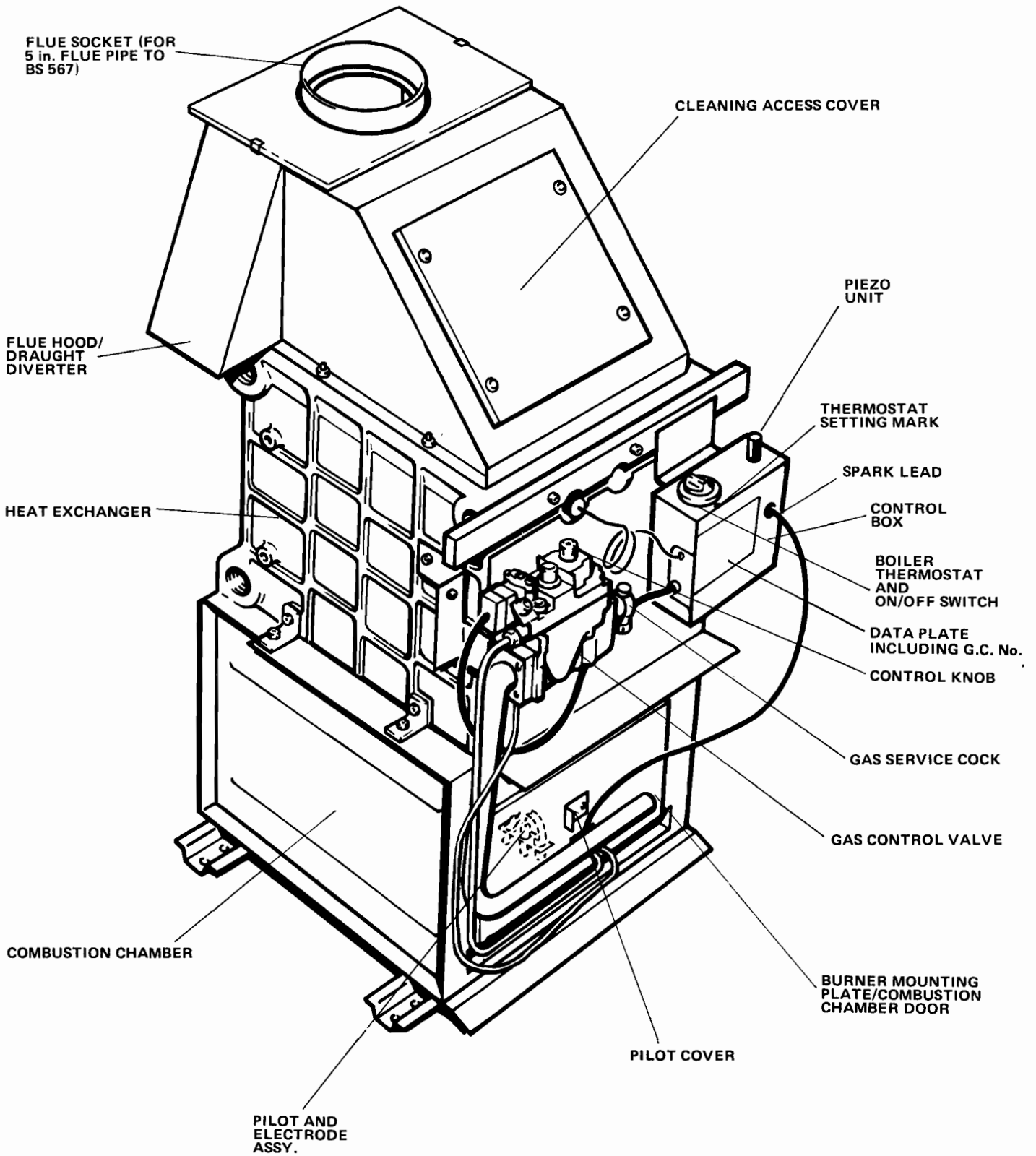

FIG. 2 GENERAL ARRANGEMENT CF 80 and CF 100

8. If the optional circulating pump kit is not used then the circulating pump may be fitted on either the flow or return side of the boiler. If fitted on the flow and the open vent pipe is located between the boiler and the pump, the risk of air being drawn into the system is reduced. If fitted on the return, the cold feed pipe should be connected between the pump and the boiler, but extra care should be taken to ensure that air will not be drawn into the system. Ideally the static head on the inlet side of the pump should be at least a third of the maximum pump duty.
9. A drain cock(s) should be fitted at the lowest point(s) in the system, so that the whole system can be drained.
10. It is recommended that all pipework to the boiler should include union fittings at suitable points to facilitate connection of the gas and water supplies.

BOILER BASE

A level floor, which conforms to the Local Authority and Building Regulations, should be provided. Normally, no insulation beneath the boiler is required as the floor temperature beneath conforms to the requirements of BS.5258. However, some composition floors which tend to soften or deform at low temperatures, may need insulating.

CLEARANCES AROUND THE BOILER

The position selected for the boiler must give the following minimum clearances for installation and maintenance:

- 610 mm (2 ft.) at the front
- 20 mm (¾ in.) at the top
- 25 mm (1 in.) at each side

The correct minimum clearance at the back of the boiler is automatically obtained once the boiler is pushed up against the wall.

There is room inside the casing to install a circulating pump.

COMBUSTION AIR AND VENTILATION

A. Ventilation of compartments containing gas boilers.

There should be two permanent air vents, one at low level and one at high level, both communicating either directly with outside air or with a room or space which is suitably ventilated. Each opening whether left free or furnished with a grille, must have a minimum effective area in accordance with Table 2.

**TABLE 2 –
COMBUSTION AIR AND VENTILATION REQUIREMENTS OF COMPARTMENTS**

BOILER TYPE	LEVEL OF AIR VENT	AREA FOR AIR FROM ROOM	AREA FOR AIR FROM OUTSIDE
CF 80	High	44 in. ² 284 cm ²	22 in. ² 142 cm ²
	Low	88 in. ² 568 cm ²	44 in. ² 284 cm ²
CF 100	High	52 in. ² 336 cm. ²	26 in. ² 168 cm ²
	Low	104 in. ² 672 cm ²	52 in. ² 336 cm ²

Any internal surface of the cupboard that is made of a combustible material and is nearer to the boiler than 75 mm (3 in.) should be insulated as described in British Gas publication "British Gas Specifications for Domestic Wet Central Heating Systems".

B. Ventilation of rooms containing gas boilers

The ventilation of the room containing the boiler shall include air for combustion and draught diverter dilution. This applies also when the boiler is sited in a compartment, unless the air vents are both direct to outside.

A permanent air vent shall be provided in an outside wall of the building at either high or low level.

This opening may be:

- (a) Directly into the room or space containing the boiler, or
- (b) Via a duct through a wall or the roof into the room, (where such a method is considered, British Gas should be consulted), or
- (c) Into an adjacent room or space which has an internal permanent air vent of the same size to the room containing the boiler. It is undesirable to ventilate via a kitchen, bathroom or toilet.

The air vent should be sited as far as possible from any extract fan to avoid short circuiting. To avoid the possibility of freezing water pipes, the vent should not be sited near the pipes.

The minimum effective area of the permanent air vent must be as follows:—

- CF 80 – 106 cm² (16½ in.²)
- CF 100 – 139 cm² (21½ in.²)

If the room (e.g. a kitchen) from which air is drawn, has an extract fan fitted, then the opening size of the permanent air vent should take this into account to ensure that the operation of the boiler flue is not adversely affected when the extract fan is running with all doors and windows closed. This should be checked in accordance with BS.5440 Parts 1 and 2.

C. Grilles and Ducts

Any grille and/or duct should be so sited and of a type not to become easily blocked or flooded and should offer low resistance to air flow.

FLUE

An efficient flue system must be provided to evacuate the products of combustion from the boiler. Reference should be made to The Building Regulations and British Standard 5440 Part 1. The following notes have been compiled for your guidance:—

- (a) Ideally a flue should rise vertically to a termination point which is unaffected by downdraught or wind eddies and is not in a pressure zone. Therefore, for practical purposes, the flue should have the shortest possible run to external atmosphere, with as near vertical rise as possible; 90° bends should be avoided. The terminal must be at least above roof edge level.
- (b) There should be at least 2 ft. (600 mm) of vertical flue from the boiler flue socket.

NOTE: Some Gas Regions insist on a split socket in this length.

- (c) Horizontal runs should be avoided. If a near horizontal flue run is unavoidable, the total vertical height necessary should be calculated in accordance with section 12.7.2 of BS.5440 Part 1.

- (d) Wherever possible internal stacks should be used.
- (e) All brick chimneys without an integral lining must be lined with either asbestos cement flue pipe to BS.567 or stainless steel flexible lining.
- (f) Where condensation is likely, a means of draining must be provided.
- (g) If an existing flue is being used, ensure that it has been thoroughly swept before lining or connecting the boiler.

ELECTRICITY SUPPLY

A 240 volts A.C., 50 Hz., single phase electricity supply fused to 3 amperes, must be provided in accordance with the latest wiring edition of the Institute of Electrical Engineers Regulations for the Electrical Equipment of Buildings, Local Authorities and British Gas requirements. The current rating of the wiring to the boiler must exceed 3 amperes in accordance with BS.6500:1975:Table 16, and have a cross sectional area of at least 0.75 sq.mm (24/0.20). The method of connection to the mains electricity supply must facilitate complete isolation of the appliance, preferably by the use of a fused 'three-pin' plug and shuttered socket outlet; both complying with the requirements of BS1363. Alternatively, a fused double pole switch, having a 3mm contact separation in both poles and serving only the appliance, may be used.

GAS SUPPLY

The gas meter and installation pipe should be checked to ensure that they are large enough for the boiler and any other appliance already installed; the local Gas Regional Office will assist in this matter. The latest recommendations of CP.331, Parts 2 and 3 should be observed.

SAFETY VALVE

If the local authorities regulations stipulate that a safety valve should be fitted, this should be installed in the flow pipework as close to the boiler as possible.

SERVICING

The efficient performance of this boiler is dependent upon regular servicing which should be carried out annually. Servicing is best arranged by a contract placed with Potterton International Limited, and further details are available from the local Potterton Regional Service Office.

Servicing is a simple matter, as once the casing front panels have been removed, all parts that are likely to require servicing are easily accessible.

SETTING UP

Each boiler has to be adjusted once it is installed and this is a skilled job which should only be undertaken by suitably qualified engineers. Potterton International offer this service on a chargeable basis.

ADDITIONAL CONTROLS

Potterton Electronic Programmers are available as optional extras. These electronic programmers have been developed to complement your boiler and offer the user a variety of programmes to suit individual requirements and systems. They are attractively styled with a constant digital clock display, slider and push buttons which are easy to use and understand. This control is fully described in its own Data Sheet which is available on request.

LITERATURE

The following literature is supplied with each boiler:

- Installation and Servicing Instructions
- User's Instructions

NOTE: Illustrated parts catalogues for these boilers are available to installers and servicing agents on request to Potterton International Limited, Brooks House, Coventry Road, Warwick CV34 4LL.

IMPORTANT

This appliance is certified by B.S.I. for safety. It is therefore important that no external control devices (e.g. flue dampers, economisers, etc.) be directly connected to this appliance unless covered by these installation instructions or otherwise recommended in writing.

Any direct connection of a control device not approved by Potterton could invalidate the B.S.I. certification and the normal appliance warranty.

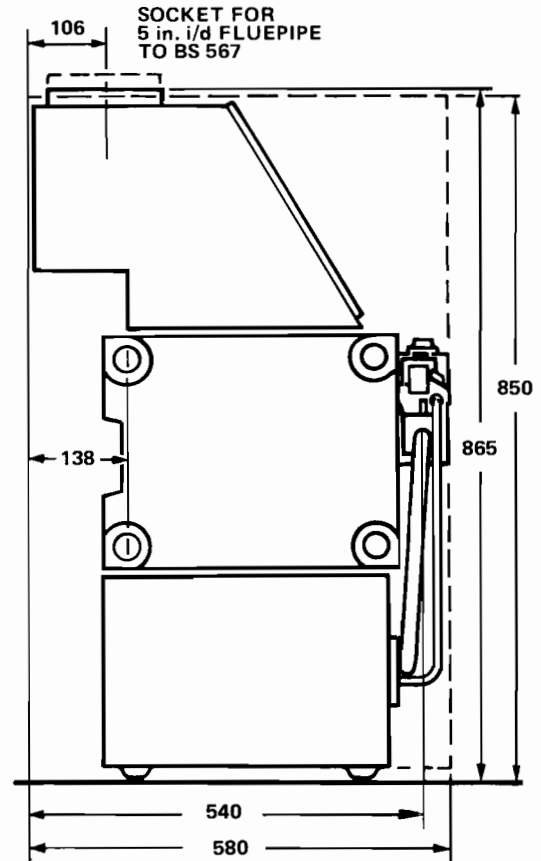
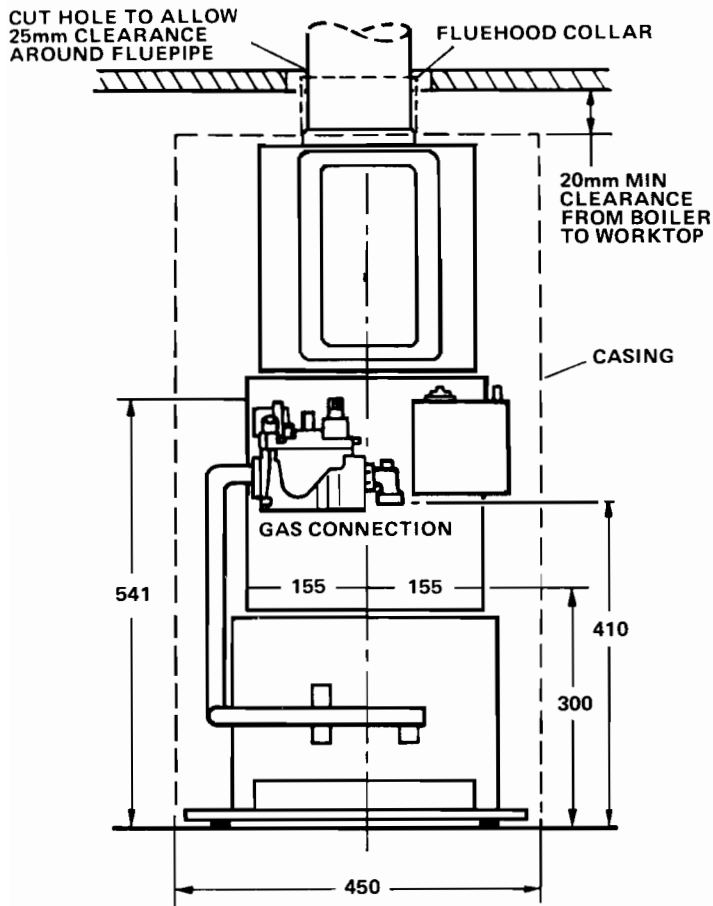

FIG. 3A CONNECTIONS AND DIMENSIONS CF 80

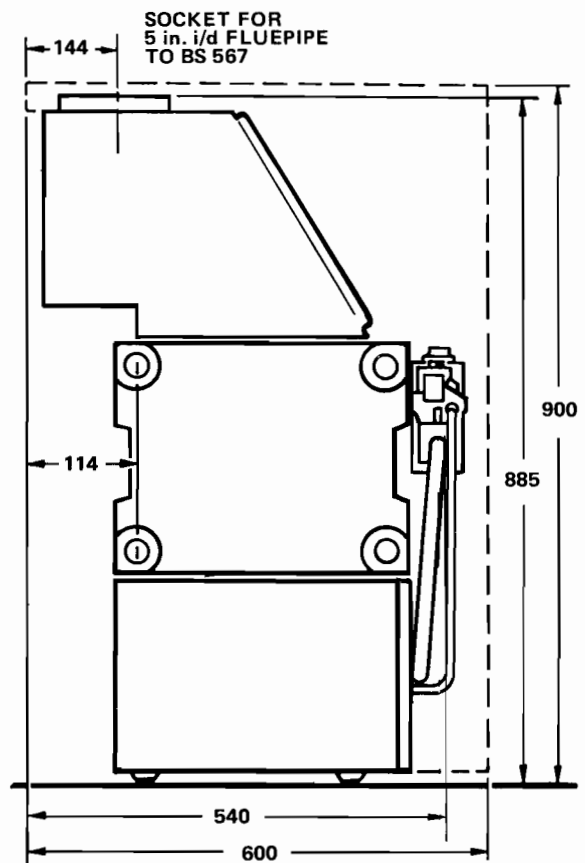
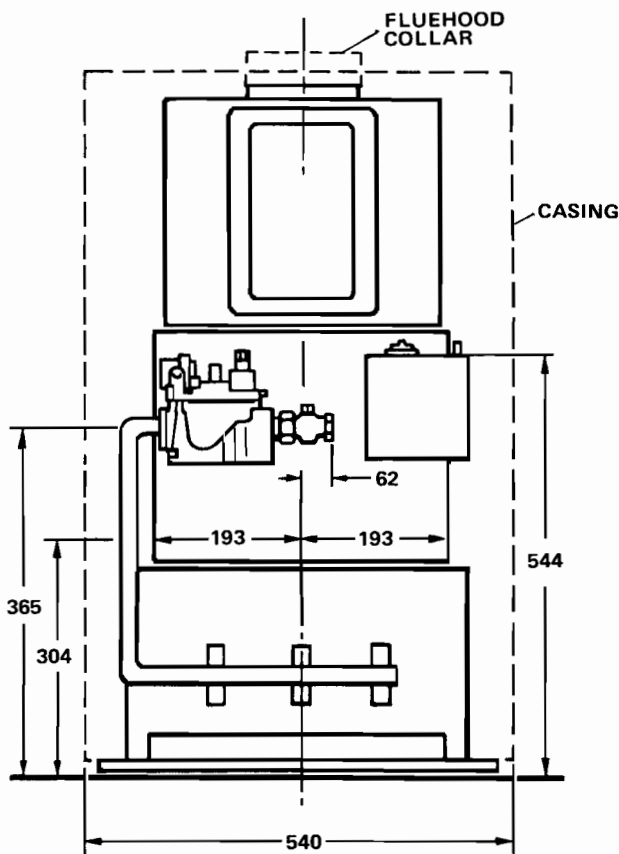

FIG. 3B CONNECTIONS AND DIMENSIONS CF 100

INSTALLATION SECTION

INSTALLATION INSTRUCTIONS

Installation must be carried out in accordance with the relevant British Standard Codes of Practice and I.E.E. recommendations. Reference should also be made to British Gas Publication "British Gas Specifications for Domestic Wet Central Heating Systems".

1. UNPACKING

A. The appliance will arrive on site in two cartons as follows:—

Carton 1: Boiler Assy., and literature

Carton 2: a) Case Top; b) Side Panels; c) Case Front, Panel (2); d) Plinth; e) Fastener Pack; f) Flue collar; g) Side panel infill.

B. Open Carton No.1 – Boiler Assy. There is no need to open the casing carton at this stage.

2. POSITIONING THE BOILER

A. CF.80 only. For transportation purposes, the fluehood is packed assembled and reversed on the top of the boiler heat exchanger. Remove the fluehood and fit it in its correct position to the studs on the heat exchanger, securing it with the four nuts and washers. Ensure a gas tight seal is made between the top of the heat exchanger and the fluehood.

B. Manoeuvre the boiler into position until the draught diverter touches the wall.

C. When the boiler has been finally positioned, check that it is level.

3. CONNECTIONS – See Connection Guide A, B & C

A. 1. The thermostat pocket is positioned in the Heat Exchanger to provide satisfactory operation for the pipework options shown in Connection Guide A, B & C. No attempt should be made to alter the position of the thermostat pocket.

2. The Heat Exchanger represented in the Connection Guide is the CF.80 but the same principle of connection applies also to the CF.100.

B. Make the flow and return connections in accordance with normal practices. Do not obstruct the opening beneath the draught diverter at the rear of the boiler.

C. On certain combined systems, i.e. pumped central heating and gravity hot water, it may be necessary to install a check valve to prevent gravity circulation in the heating circuit when the pump is not working. The valve must be installed with the arrow on it pointing vertically upwards in the direction of flow.

D. The circulating pump can be fitted in any position on either the flow or return, to suit the particular installation. Refer to "The System" and the pump manufacturers instructions. If internal pump fitment is required, it is recommended that the Potterton pump kit should be used.

E. Connect the gas supply pipe to the boiler gas service cock.

F. Ensure the drain cock(s) is fitted.

G. Remove the circulating pump, open all water valves and thoroughly flush the system.

H. Refit the pump, fill and vent the system and test for water soundness; rectify if necessary.

4. FLUE (See Fig.3)

Slide the flue collar assembly onto the fluepipe prior to fixing to boiler. Position flange to rear.

Make the flue connection to the boiler draught diverter, sealing the joint with a suitable compound.

5. WIRING (See Figs.4 to 10)

Care must be taken to ensure that all wiring to the boiler is kept clear of sharp edges and hot surfaces. Cable clips are provided to secure the input cable to the boiler casing.

Ensure that sufficient input cable is provided to allow routing along the top of casing side panel. (See Section 9 – Casing).

Unscrew the side screw and hinge the control module forward to expose the terminal strip.

NOTE: Ensure that the earth conductor is longer than the L and N from the point of anchorage, so that the current carrying conductors become taut before the earth conductor.

CONNECTION GUIDE FOR CF80

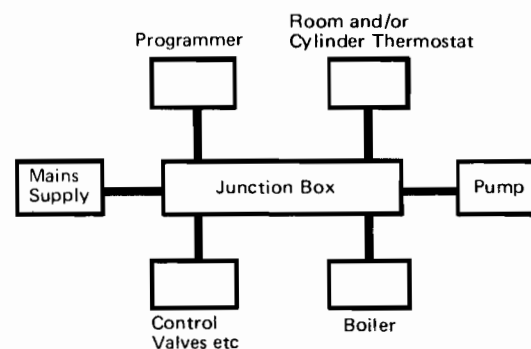
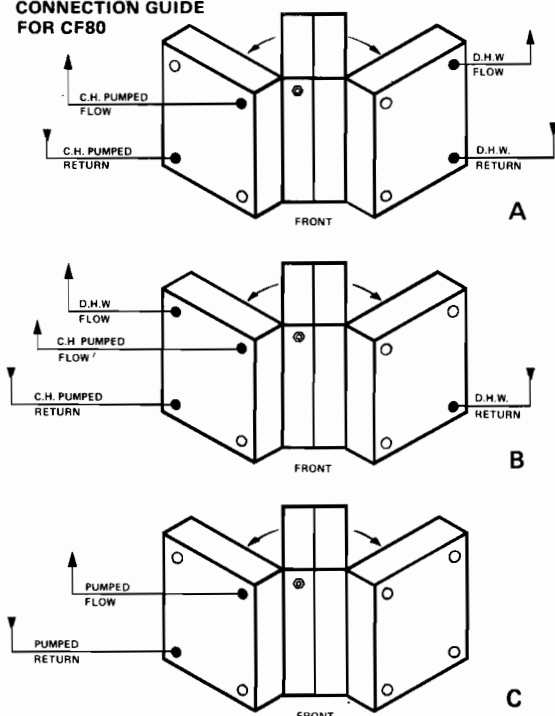

FIG. 4 PRINCIPLE OF WIRING

The boiler terminal strip is not designed to accept wiring from all the on-site system controls and therefore, the installer will need to incorporate a suitable junction box. The principle of wiring up the boiler and its controls is shown in Fig.4. However, the layout of a particular system will itself govern the most economical location for the junction box and its terminals.

Wire up the boiler and system controls as illustrated in Figs. 6,7,8,9 or 10 depending on the type of system installed. The wiring arrangements shown, outline only the basic control requirements and will therefore require on-site interpretation of the various boiler installation arrangements. Fig.9 illustrates a system with a zone valve which requires an electrical supply to motor it both to the open and closed positions. Zone valves which require an electrical supply to open them but not to close them, should be wired in a similar manner but ignoring the closed connection from the room thermostat. For this type of valve, a room thermostat with a single pole contact may be used. Certain zone valves may require an additional connection to the auxiliary switch (shown dotted). This would apply to those valves which internally are not suitable for giving an open signal from the normal opening voltage supply.

If a Potterton EP 2000/3000 Programmer is not being fitted, but a three terminal time clock is to be installed to control the systems illustrated in Fig.6,7,8,9 and 10 the time clock should be wired as follows:-

- Live to Time Clock Live
- Neutral to Time Clock Neutral
- Earth to Time Clock Earth
- Wires normally connected to EP 2000/3000
- Terminals 3 & 4 to Time Clock Switch

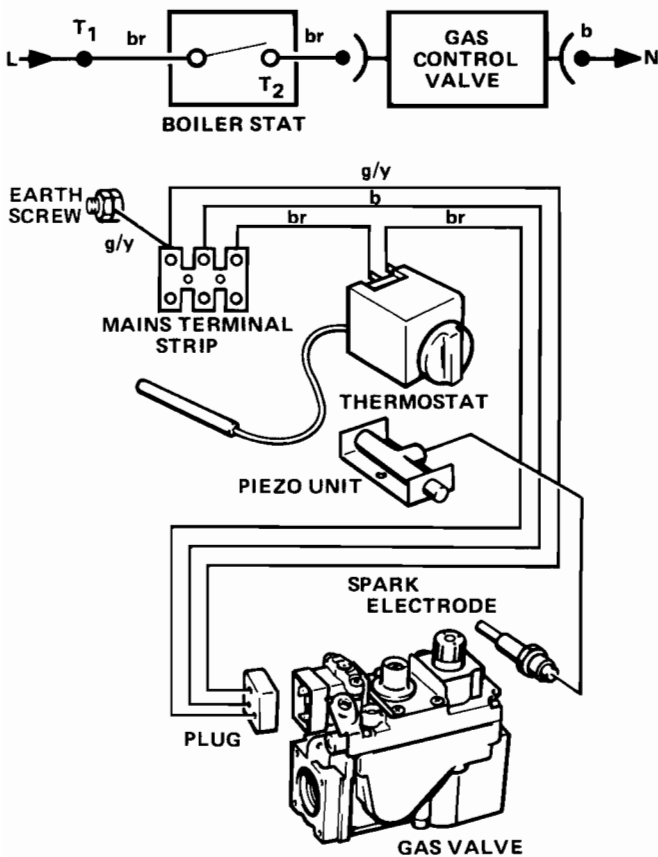

FIG. 5 WIRING DIAGRAMS

A low limit thermostat can be installed to override the "OFF" setting of the time control. Where an EP 2000/3000 or other programmer is installed, a double pole or a single pole thermostat with change over contacts may be necessary; for the electrical connections and type required, see the relevant system wiring diagram.

Where only a time clock is fitted, the thermostat need only be a single pole type with its contact wired in parallel with the clock switch.

If a three-way (proportioning diverter) valve with a mid-position is being fitted in the system, the following must be adhered to in addition to the valve manufacturer's wiring information:

1. Neutral and earth connections must be made to boiler terminals N and E.
2. The switched supply from the system control circuit must be connected to boiler terminal L.
3. The live supply to the pump must be taken from the supply to boiler terminal L.

When all wiring is complete, fit the control module into its housing and secure it with the side screw.

6. COMMISSIONING THE BOILER

Before lighting the boiler, the whole of the gas installation, including the meter, must be inspected and tested for soundness, and purged, in accordance with the recommendations of CP.331: Part 3: 1974.

6.1. PRELIMINARY ELECTRICAL SYSTEM CHECKS

In the event of an electrical fault after installation of the appliance, preliminary electrical system checks, as described in the B.G.C. Multi-meter instruction book must be carried out. The checks to be carried out are:- A. Earth Continuity Check; B. Short Circuit Check; C. Polarity Check; and D. Resistance to Earth Check; See Figures 5 and 11.

IMPORTANT

This series of checks are the first electrical checks to be carried out during a fault finding procedure. On completion of a service/fault finding task which has required the breaking and re-making of electrical connections, then the checks A. Earth Continuity; C. Polarity; and D. Resistance to Earth must be repeated.

FIG. 6 GRAVITY HOT WATER WITH PUMPED CENTRAL HEATING

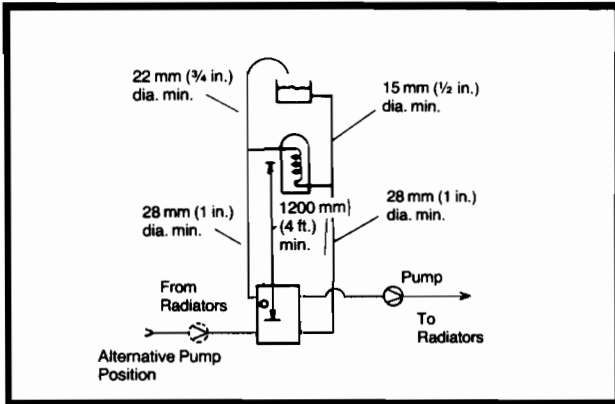

FIG. 7 GRAVITY HOT WATER WITH TEMPERATURE CONTROL AND PUMPED CENTRAL HEATING

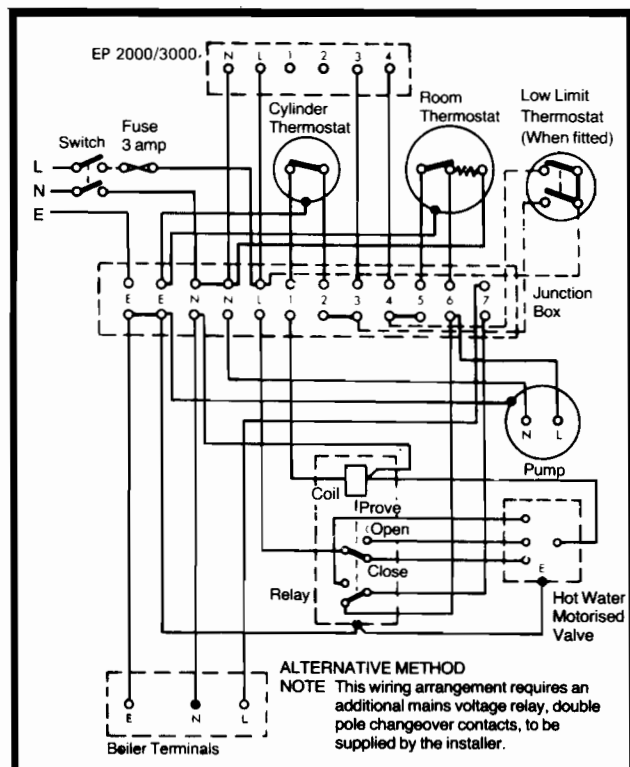
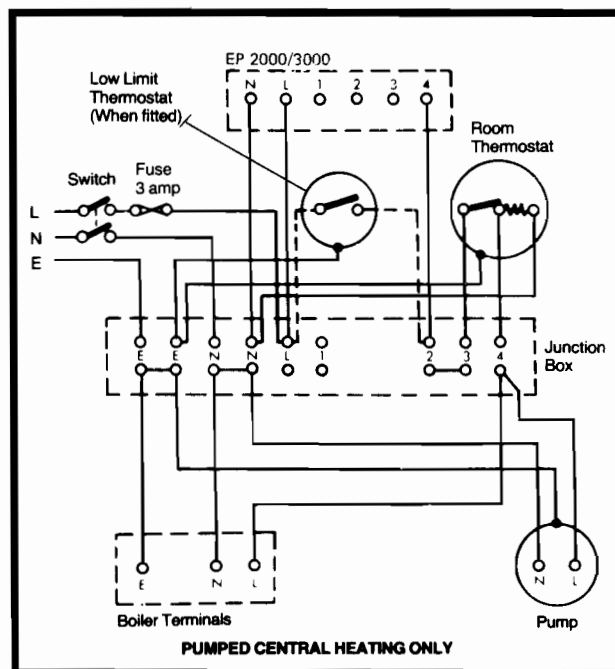
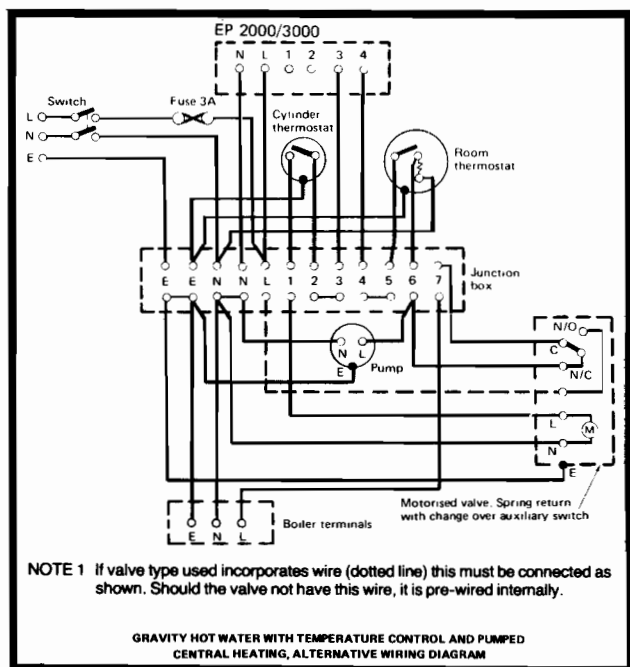
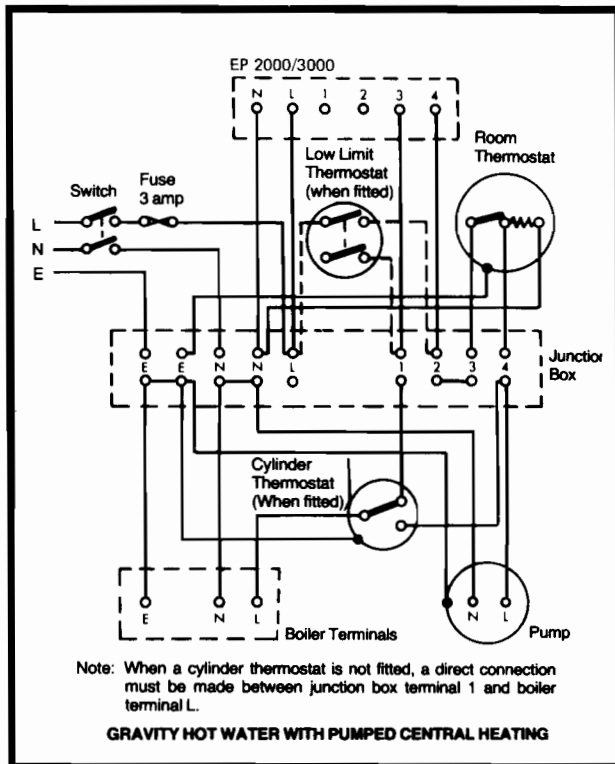
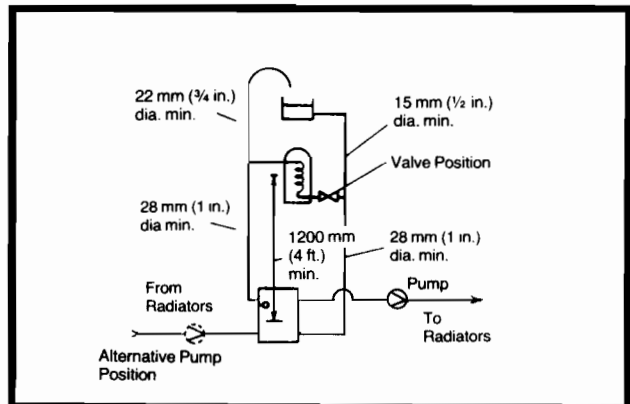

FIG. 8 FULLY PUMPED WITH TWO POSITION DIVERTER VALVE

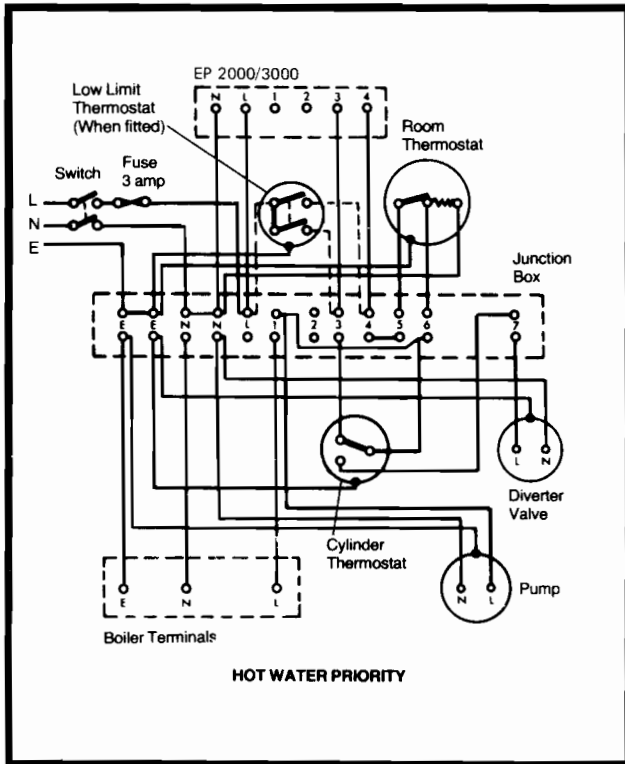
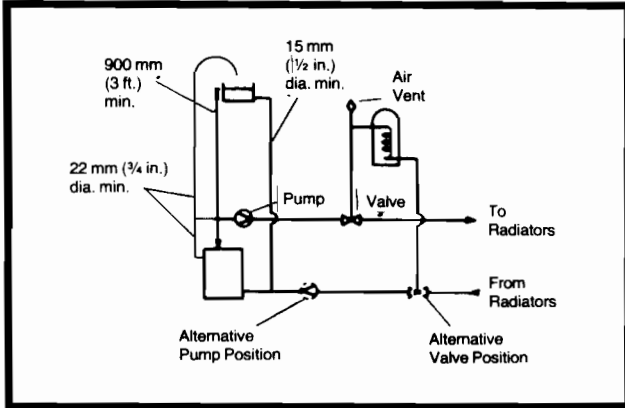

FIG. 9 FULLY PUMPED WITH ONE OR TWO ZONE VALVES

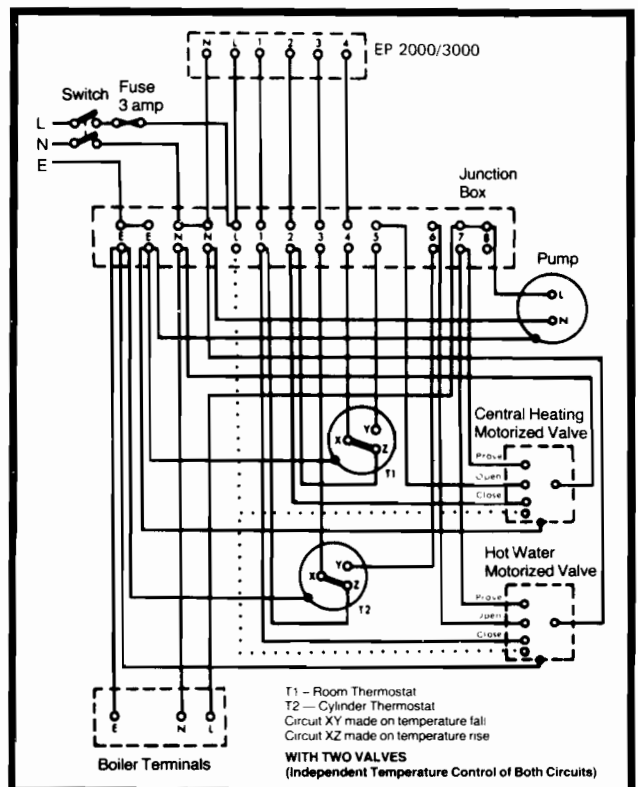
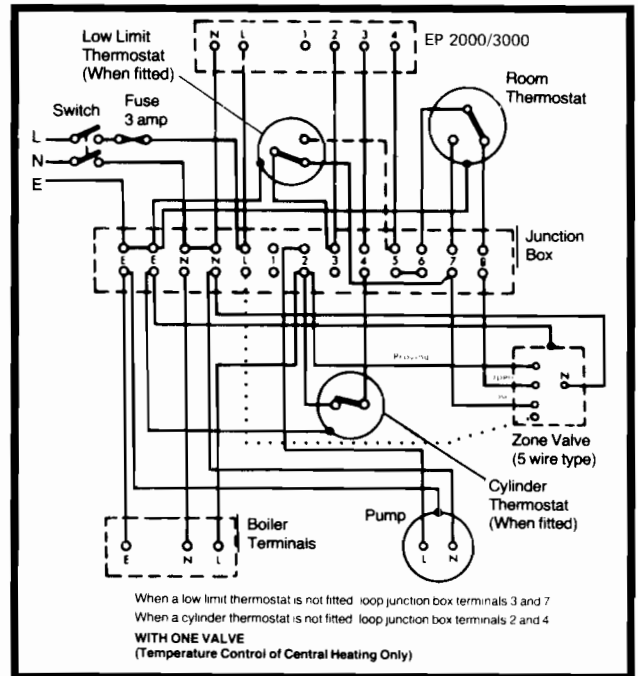
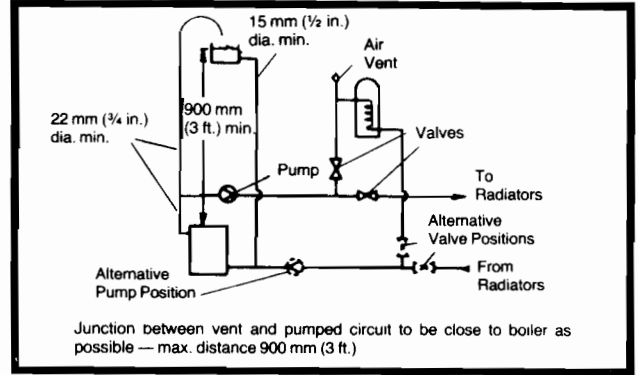
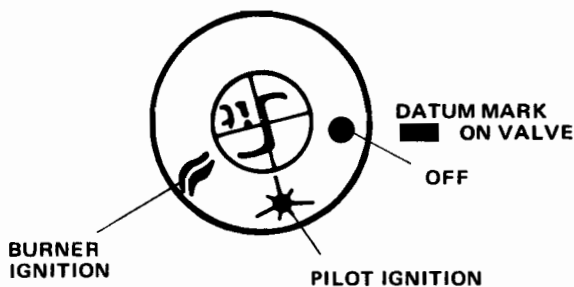
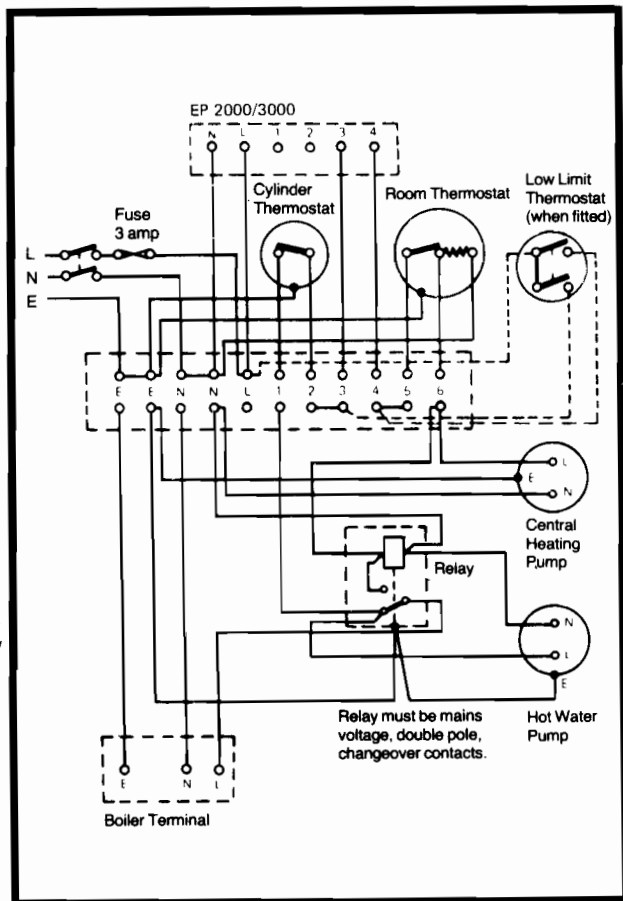
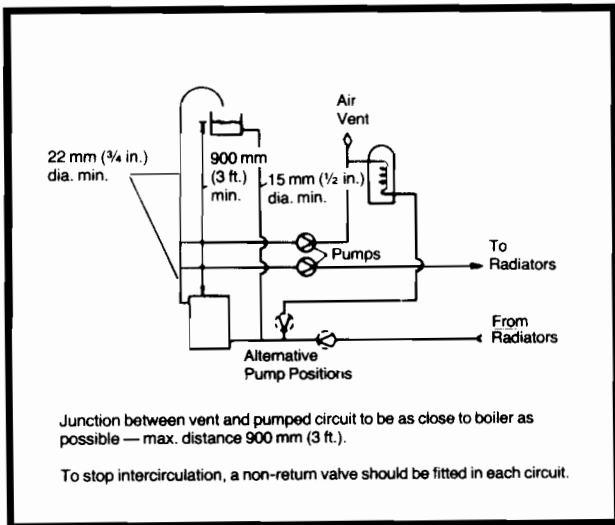

FIG. 10 FULLY PUMPED USING TWO PUMPS



7. LIGHTING

- A. Check that the main electricity supply to the boiler is switched on and that the boiler thermostat is in the off position.
- B. Turn on the main gas supply.

WARNING: OPEN ALL WINDOWS AND EXTINGUISH ANY NAKED LIGHTS IN THE ROOM AND PUT OUT PIPES AND CIGARETTES.

- C. Break the union at the boiler gas service cock, then open the cock and purge any air from the supply pipe. See CP.331, Part 3.
- D. Close the cock, re-make the union then re-open the cock and test for gas soundness using a soap solution.

WARNING: DO NOT USE A NAKED FLAME,

- E. Ensure that the system is full of water and that the pump and radiator isolating valves are open.
- F. Ensure that the time control, if fitted, is in an ON condition, and that the room and/or cylinder thermostats, where fitted, are set to high temperatures.
- G. Turn the control button on the gas control valve clockwise as far as possible and release it. This ensures that the valve is in the off condition.
- H. Lift the tab and swing aside the small cover above the pilot burner. Turn the control knob on the gas control valve so that the stylised ignition symbol lines up with the mark on the gas valve body. (See knob details). Press and hold in the control knob and press the ignition button until a click is heard. Release the ignition button and repeat operation until the pilot ignites. Hold in the control knob for a further 15 seconds on release the pilot should remain alight. Turn the control knob anti-clockwise until the stylised flame symbol lines up with the mark in the valve body. Swing back the small cover above the pilot burner.

NOTE: On first lighting, establishment of the pilot flame may be slightly delayed due to the presence of air in the pipework. If the pilot fails to light or goes out at any time, immediately depress and turn the control button clockwise as far as possible then release it and wait three minutes before repeating the lighting procedure. The control button should not be touched during this period.

- J. Turn the boiler thermostat on and to a high setting and the main burner will light.
- K. Set the boiler thermostat and the room and/or cylinder thermostat(s) and time control, where installed, to their required operating conditions.
- L. Check that there is no spillage or leakage of combustion products in accordance with BS.5440, Part 1. Check gas soundness of joints using leak detection fluid.

- M. Allow the system to reach maximum working temperature and examine for water soundness.
- N. Switch off the boiler, using the thermostat knob.
- P. Drain the system whilst it is still hot, then refill and vent and make a final examination for soundness.

NOTE: If any difficulty is experienced in lighting the boiler, refer to the fault finding chart at the end of this booklet.

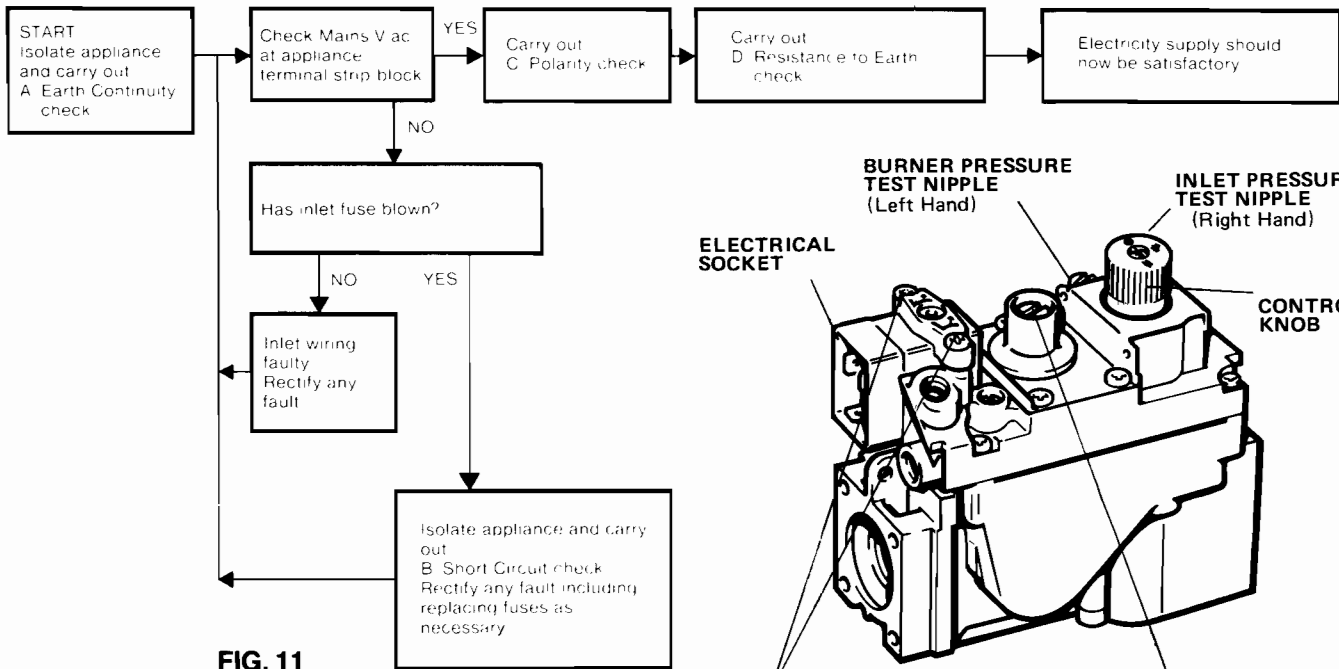

FIG. 11

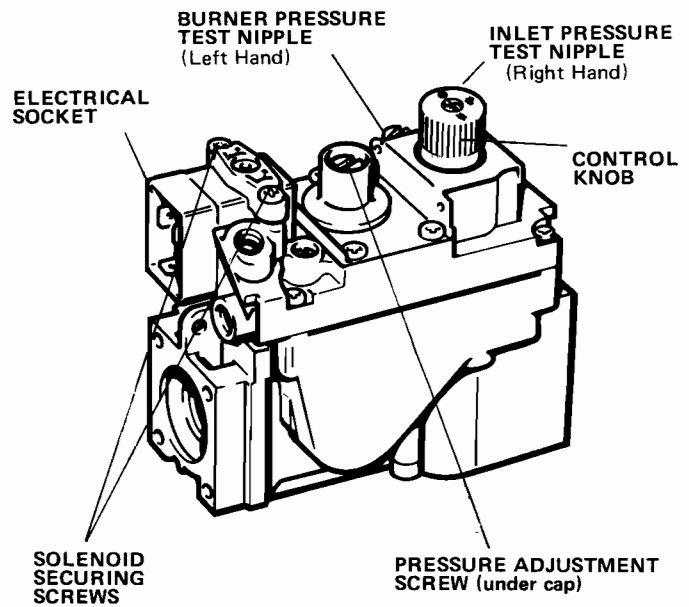

FIG. 12

8. FINAL ADJUSTMENT

A. Gas Rate and Main Burner Pressure Setting

1. Fit a pressure gauge to the pressure test nipple. See Fig.12.
2. Turn on the boiler thermostat, then check that the burner pressure is in accordance with Table 1.
3. If burner pressure adjustment is necessary, remove the screwed cap on the top of the control valve and turn the screw beneath clockwise to increase pressure or anti-clockwise to decrease. Refit the screwed cap when the pressure is correct. Shut down the boiler, remove the pressure gauge and refit screw in the pressure test nipple.
4. With the burner set to its correct pressure, the firing rate given in Table 1 should also be obtained and this should be checked by meter reading over a period of at least 10 minutes once the boiler is hot.

B. Pilot Burner

When correctly set, the pilot flame must be sufficient to heat the thermo-couple so that the pilot safety device is "held in" but must not cause the thermo-couple to glow bright red. If the pilot needs adjustment, turn the self sealing pilot adjustment screw, located adjacent to the pilot connection on the gas control valve, clockwise until closed then anti-clockwise 3 full turns.

The correct adjustment is achieved when the pilot flame completely envelops the top 4 mm (approximately 0.16 in.) of the thermo-couple, see Fig.13. When the pilot is set to the above instructions the E.M.F. generated by the thermo-couple should be of the order of 20 – 30 mV open circuit, 10–14 mV closed circuit. Drop out should occur between 1–3 mV closed circuit.

C. Boiler Thermostat

1. At its minimum and maximum settings, the thermostat should control the water flow temperature at approximately 55°C to 82°C (130°F to 180°F) respectively.

2. The thermostat has been calibrated by the makers and no attempt should be made to recalibrate it on site. Turn the thermostat to the off position and check that the main burner shuts down.

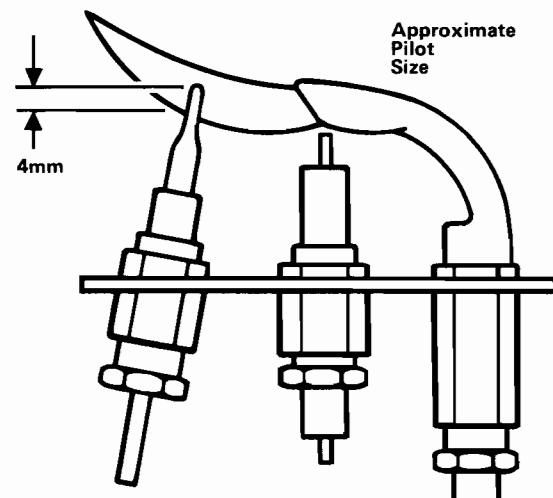

FIG. 13

D. Combination Control

Solenoid:

Check the operation of the valve by turning off the electricity supply either by the isolating switch or the time control, where installed. The main burner must shut down immediately.

Flame Safety Valve:

Check the operation of the valve as follows with the boiler running normally:— Turn the control button clockwise as far as possible and a distinct click should be heard within 60 seconds indicating that the valve has closed.

E. Remote Controls:

Check that any other remote control connected in the system such as time clocks and thermostats, control the boiler as required.

9. CASING – See Fig. 14

- A. Remove the casing pack contents and check against parts list:–
- Case Top Panel
 - Side Panels (left and right hand)
 - Case Front Panels (upper and lower)
 - Plinth
 - Fastener Pack
 - Side Infill Panel
 - Fluehood collar (fitted in Section 4 FLUE. CF.80 one piece, CF.100 two piece).
- B. The front tie strap is located in it's transit position attached to the heat exchanger. Remove the tie strap prior to case erection.
- C. Fit the captive nuts supplied in the fastener pack to the hole positions shown in Fig.14 (13 off including 2 for the side infill panel). The four smaller captive nuts and screws contained in the additional polythene bag should be used for the plinth.
- D. Electrically isolate the boiler and remove the screw at the left-hand side of the control box. Hinge down to expose the inside of the control box. Remove the control box from its transit position attached to the heat exchanger.
- E. Fit the front tie strap to the heat exchanger using the 2 M6 transit screws. Do not fully tighten the screws at this stage.
- F. Fit the control box to its correct position on the bracket attached to the tie strap. Hinge the control box into the housing and refit the side screw. Ensure the thermostat phial is pushed fully into the pocket and securely located by it's retention clip.
- G. If required the side infill panel may be fitted to the left or right hand side to improve the side appearance of the boiler.
- The side panels are identified by the location label fitted to the lower rear corner of the side panel.
- H. Fit the case adjustment brackets to each end of the front tie strap as shown in Fig.14. Do not fully tighten the screws at this stage.
- J. Using the locating labels, fit the correct holes in the side panels over the knibs on the rear of the boiler mounting channels.
- K. Screw through the side panels and into the front fixing of the adjustment brackets. Tighten the top screws on the adjustment brackets.
- L. Fit the cable retaining clips to the top flange of the appropriate side panel. Ensure that the mains input cable is routed away from hot surfaces and sharp edges.
- M. Locate the plastic panel fasteners on the top panel into the larger diameter of the keyhole cut-outs in the top flange of the side panels. Slide the top panel towards the wall to secure in position, and screw through the side panel flange into the captive nut in the top panel.
- N. Square up the casing assembly and fully tighten the M6 screws fixing the front tie strap to the heat exchanger.
- P. It is now possible to lower the flue-hood collar onto the top panel and push into position over the boiler fluehood socket. The CF.100 fluehood collar is a two-piece assembly, push the ring over the socket and rest the flat plate in the depression in the casing top panel. Position the flange towards the wall.

- Q. Fit the plinth to the 4 captive nuts at the base of the side panels using the screws and washers from the additional polythene bag. The two lugs on the plinth should be forward facing.
- R. Fit the brass studs to the smaller hole of the bank of three holes in each side of the upper front panel using the M5 nuts and shakeproof washers. Push firmly home into the retainers in the side panels.
- S. Fit the panel restrainer together with its captive nut to the right hand side of the lower front panel. (See Fig.14). The fixing hole is below the bank of three holes in the right hand side return flange.

Fit the brass studs to the smaller holes of the bank of three holes in each side of the lower front with the two M5 nuts and shakeproof washers.

- T. Locate the two slots on the bottom flange of the lower front panel over the locating lugs on the plinth, spring the panel restrainer inside the side panel flange and push firmly home into the retainers in the side panel.

The case assembly is now complete. It is possible to adjust the boiler thermostat, or turn the boiler off without removing the lower front panel, simply pull the panel forward and allow the restrainer to rest against the side panel.

If a second side infill panel (CF.80 and CF.100) or casing top panel extension to allow flush fitting with 900 mm kitchen units (CF.80 only) are required, they may be obtained as optional extras.

NOTE: On opened flued boilers, no attempt should be made to cover the open area at the rear of the side panels.

10. INSTRUCT THE USER

User's Instructions are provided with this boiler, but, if possible, the installer should explain the operation of the boiler and system to the householder.

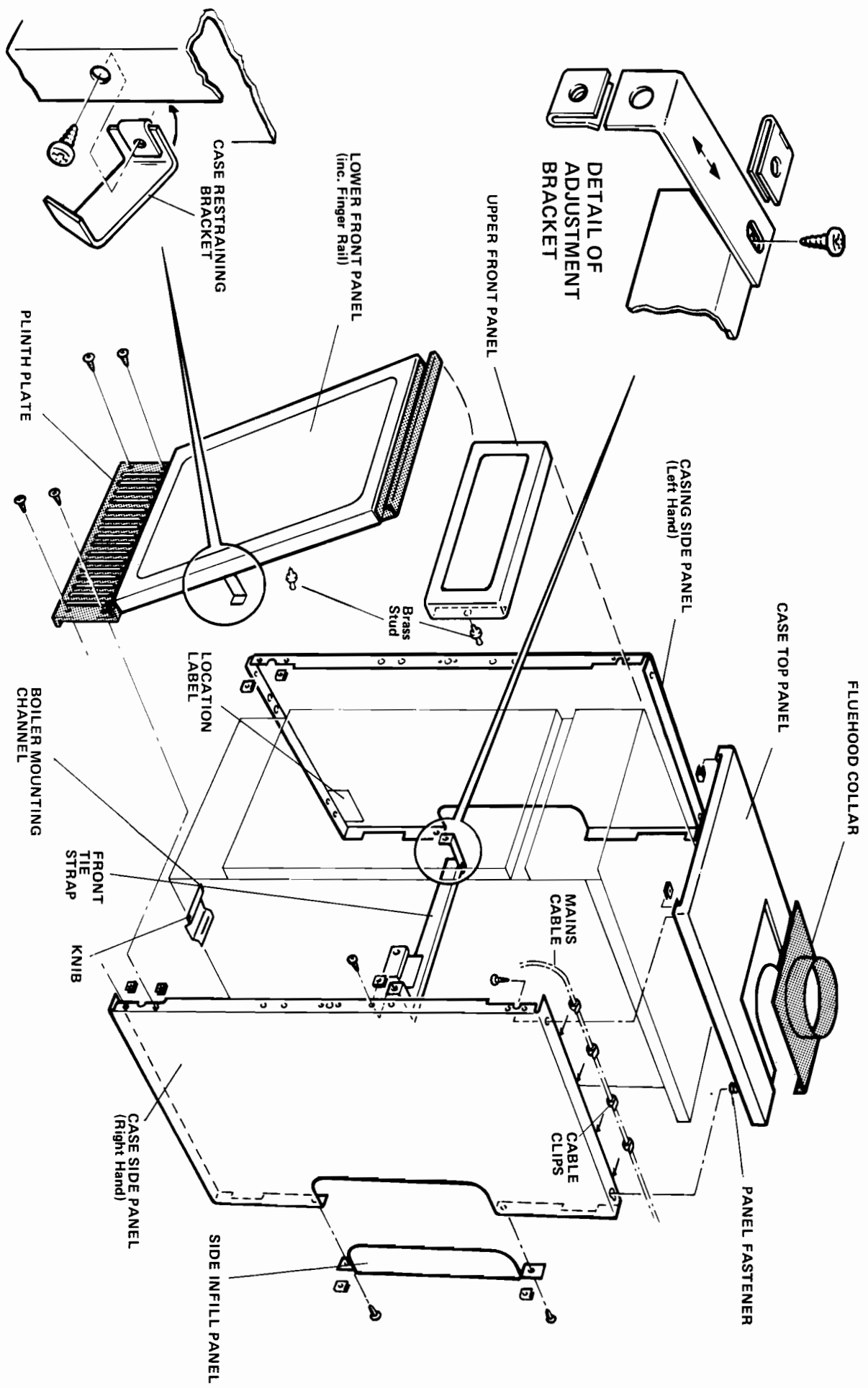

FIG. 14

SERVICING SECTION

SERVICING INSTRUCTIONS

To ensure continued efficient operation of the boiler, it is necessary to carry out servicing and cleaning at regular intervals. Only competent people may install or service gas appliances or systems.

The frequency of cleaning will depend upon the particular installation conditions, and the use to which the boiler is put, but in general, once per year should be adequate.

The following notes apply to the boiler and its controls, but, it should be remembered that attention must also be paid to the heating circuit itself including radiator valves, thermostats, the time control and the expansion and feed water system. In all cases prior to servicing, light up the boiler and check the pilot and main burners have a clean, even flame and that the gas rate and main burner pressure is correctly set.

Before the start of any service work, switch off the main electricity supply and disconnect the plug at the main isolating switch and socket. Turn off the boiler main gas service cock.

NOTE: Where it is required to break any seal during servicing the seal should be examined carefully for damage and if necessary replaced. It is important to obtain the correct Potterton approved part for the seal replacement which is available from Interpart spares stockists, or where difficulty in supply is experienced, directly from Potterton International Limited.

After any servicing or component replacement, the boiler commissioning procedure should be carried out. (See Installation Section).

1. PREPARING THE BOILER

- A. Remove the casing upper and lower front panels by pulling forward.
- B. Remove the four securing screws, then remove the plinth.
- C. The top panel may be removed if necessary for easier access.

2. MAIN BURNER ASSEMBLY – REMOVAL AND CLEANING

- A. Disconnect the union in the main gas supply pipe at the gas service cock.
- B. Remove the single forward facing screw (CF.80), two screws (CF.100), securing the bracket on the gas valve to the bracket on the side of the heat exchanger.
- C. Unplug the lead to the gas valve from the control box, and disconnect the spark lead from the piezo unit.
- D. Remove the four screws securing the combustion chamber front cover and remove the cover complete with the burner and gas arrangement.
- E. Remove all deposits from the main and pilot burners, thermo-couple and spark electrode.
- F. Remove and inspect the pilot injector for dirt deposits and clean if necessary. The pilot injector may be extracted using a blunt tool such as an Allen key.
- G. Inspect and clean the main burner injectors if necessary.
- H. Remove the screws securing the burner end plates then remove the plates and withdraw the metal gauzes from inside the burners. Clean the gauzes and remove any deposits from inside the burners. Refit gauzes and end plates renewing the gaskets if necessary.

- J. Do not attempt to refit the main burner assembly into the combustion chamber at this stage, as the flueways in the heat exchanger have first to be cleaned.

3. HEAT EXCHANGER

- A. Unscrew the four nuts and remove the flue hood access cover.
- B. Working from above and below the heat exchanger, use a suitable brush and remove all deposits from between the fins of the castings.
- C. Refit the flue hood coverplate ensuring that a good seal is made. Fit and tighten the four nuts.
- D. Remove all deposits from inside the boiler combustion chamber.

4. MAIN BURNER ASSEMBLY – REPLACEMENT

- A. Replace the main burner assembly in position and secure the combustion chamber front cover with the four screws.
- B. Secure the bracket on the gas valve to the bracket on the heat exchanger with the single screw (CF.80), two screws (CF.100).
- C. Reconnect the main gas pipe at the union adjacent to the gas service cock.
- D. Plug the lead to the gas valve into the socket and reconnect the spark lead to the piezo unit.

5. OTHER BOILER COMPONENTS

No further servicing has to be carried out on any other unit. Repair is by replacement and instructions on this are given later.

6. FINAL ADJUSTMENT

- A. Remove sealing screw and fit a pressure gauge to the pressure test nipple in the gas valve (See Fig.12).
- B. Switch on the main electricity supply to the boiler and check that the boiler thermostat is in the off position.
- C. Turn on the gas service cock.
- D. Ensure that the system is full of water and that the pump and radiator isolating valves are open.
- E. Ensure that the time control if fitted, is in an on condition, and that the room and/or cylinder thermostats, where fitted, are set to high temperatures.
- F. Turn the control button on the gas control valve clockwise as far as possible and release. This ensures the valve is in the off condition.
- G. Lift the tab and swing aside the small cover above the pilot burner. Turn the control knob on the gas control valve so that the stylised ignition symbol lines up with the mark on the gas valve body. (See knob details). Press and hold in the control knob and press the piezo unit until a click is heard. Release the piezo unit and repeat operation until the pilot ignites. Hold in the control knob for a further 15 seconds, on release the pilot should remain alight. Turn the control knob anti-clockwise until the stylised flame symbol lines up with the mark in the valve body. Swing back the small cover above the pilot burner.

NOTE: On first lighting, establishment of the pilot flame may be slightly delayed due to the presence of air in the pipework. If the pilot fails to light or goes out at any time, immediately depress and turn the control knob clockwise as far as possible, then release it and wait three minutes before repeating the lighting procedure. The control knob should not be touched during this period.

- H. When correctly set, the pilot flame must be sufficient to heat the thermocouple so that the pilot safety device is "held in" but must not cause the thermocouple to glow bright red. If the pilot needs adjustment, turn the self sealing pilot adjustment screw, located adjacent to the pilot connection on the gas control valve, clockwise until closed then anti-clockwise 3 full turns.

The correct adjustment is achieved when the pilot flame completely envelops the top 4 mm (approximately 0.16 in.) of the thermocouple, see Fig.13. When the pilot is set to the above instructions the E.M.F. generated by the thermocouple should be of the order of 20–30 mV open circuit, 10–14 mV closed circuit. Drop out should occur between 1–3 mV closed circuit.

- J. Turn on the boiler thermostat and the main burner will light. Check that the burner pressure is in accordance with Table 1.
- K. If burner pressure adjustment is necessary, remove the screwed cap on top of the gas control valve and turn the screw beneath clockwise to increase pressure or anti-clockwise to decrease. Refit the screwed cap when the pressure is correct. Shut down the boiler, remove the pressure gauge and refit the screw in the pressure test nipple. With the burner set to its correct pressure, the heat input given in Table 1 should also be obtained and this should be checked by meter reading over a period of at least 10 minutes once the boiler is hot.
- L. Refit the casing plinth.
- M. Fit the casing front panels.

7. REMOVAL/REPLACEMENT OF BOILER COMPONENTS

A. Main Burner and Injector

1. Switch off the main electricity supply to the boiler.
2. Carry out operations A and B under 1. "PREPARING THE BOILER".
3. Turn off the boiler main gas service cock.
4. Remove the main burner assembly as described under 2. "MAIN BURNER ASSEMBLY – REMOVAL AND CLEANING".
5. Remove the four screws, CF.80 or six screws, CF.100, securing the burners to the combustion chamber front plate.
6. Unscrew the main burner injector from the main gas supply pipe.
7. Replacement is the reverse of removal.
8. Test the boiler as described in 6. "FINAL ADJUSTMENT".

B. Pilot Burner and Injector

1. Switch off the main electricity supply to the boiler.
2. Carry out operations A and B under 1. "PREPARING THE BOILER".
3. Turn off the boiler main gas service cock.
4. Remove main burner assembly as described under 2.

5. Disconnect the pilot supply pipe at the pilot.
6. Disconnect the thermocouple lead from the pilot assembly, then withdraw the thermocouple. Ensure that the thermocouple is clean and undamaged. Disconnect the spark lead and electrode.
7. Remove the screws securing the pilot assembly to the pilot bracket, then withdraw the pilot. The pilot injector may be extracted using a blunt tool such as an Allen key.
8. Replacement is the reverse of removal.
9. Test the boiler as described in 6. "FINAL ADJUSTMENT".

C. Thermocouple

1. Carry out operations (1) to (6) under "B. Pilot Burner and Injector".
2. Disconnect the thermocouple lead from the gas control valve, noting the route the lead takes from the pilot assembly. The replacement lead must be routed in a similar manner, so that sharp bends in the lead are eliminated.
3. Replacement is the reverse of removal.
4. Test the boiler as described in 6. "FINAL ADJUSTMENT".

D. Gas Control Valve

1. Switch off the main electricity supply to the boiler.
2. Carry out operations A and B under 1. "PREPARING THE BOILER".
3. Turn off the boiler main gas service cock.
4. Remove the main burner and gas valve assembly as described under 2. "MAIN BURNER ASSEMBLY – REMOVAL AND CLEANING".
5. Disconnect the pilot supply tube and the thermocouple lead from the gas valve.
6. Remove the service cock union nut and sleeve from the inlet end of the valve and the bracket from the outlet end and fit them to the new valve.
7. Remove the old valve from the gas supply pipe. Retain gasket for use with new valve.
8. Replacement is the reverse of removal.
9. Test the boiler as described in 6. "FINAL ADJUSTMENT".

E. Boiler Thermostat

1. Remove the casing lower front panel, by pulling forward.
2. Turn off the boiler main gas service cock.
3. Switch off the main electricity supply to the boiler.
4. Remove the screw at the left-hand side of the control box and hinge down to gain access.
5. Remove the clip then withdraw the thermostat phial from its pocket in the heat exchanger.
6. Disconnect the two wires from the thermostat.
7. Pull off the thermostat knob, then remove the two screws and washers from around the spindle of the thermostat. Remove the thermostat complete with its capillary.
8. Replacement is the reverse of removal. Ensure that the new thermostat phial is inserted to the full depth of its pocket, and re-secure with clip. Ensure the capillary is positioned away from the heat exchanger and correctly positioned in the slot at the side of the control box. (It may be necessary to use pliers to open and close the slot).
9. Test the boiler as described in 6. "FINAL ADJUSTMENT".

F. Spark Electrode

1. Carry out operations A, B and C under 1. "PREPARING THE BOILER".
2. Turn off the main gas and electricity supply to the boiler.
3. Carry out operations A to E under 2. "MAIN BURNER ASSEMBLY – REMOVAL AND CLEANING".
4. Disconnect the thermocouple and spark lead from the pilot assembly.
5. Unscrew the electrode securing nut and remove the spark electrode.
6. Fit the new electrode and ensure that the spark gap between the pilot hood and electrode is between 2 mm and 4 mm.
7. Replacement is the reverse of removal.
8. Test the boiler as described in 6. "FINAL ADJUSTMENT".

G. Piezo Unit

1. Remove casing lower panel, by pulling forward.
2. Turn off the boiler main gas service cock.
3. Switch off the main electricity supply to the boiler.

4. Remove the screw at the side of the control box and hinge down the front to gain access to the piezo unit.
5. Pull off the spark lead from unit.
6. Remove the two screws holding the piezo unit to the control box, and withdraw the unit.
7. Replacement is the reverse of removal.
8. Test the boiler as described in 6. "FINAL ADJUSTMENT".

H. Spark Lead

1. Carry out operations A, B and C under 1. "PREPARING THE BOILER".
2. Turn off the main gas and electricity supply to the boiler.
3. Pull off the lead from the pilot assembly and the piezo unit.
4. Replacement is the reverse of removal. If difficulty is experienced fitting the lead onto the unit through the hole in the front of the control box, remove the side screw and hinge down the control box to gain access to the piezo unit.

NOTE: Fit the black end of the spark lead to the piezo unit.

8. FAULT FINDING

As well as the fault finding chart given, reference should be made to the wiring diagram Fig.5. Electrical procedures described are in accordance with the Instructions for British Gas Multimeter booklet.

CONDITION	POSSIBLE CAUSE	REMEDY
A. Pilot fail to light.	<ol style="list-style-type: none"> (1) No gas supply (2) Control knob not pressed fully down. (3) Blocked pilot injector (4) Piezo unit not working (5) Electrode or lead damaged 	<p>Check all cocks are open in the supply to the boiler.</p> <p>Control knob must be pressed fully down.</p> <p>Remove and change the injector as described in Section 7.B.</p> <p>Check that the striker and plunger mechanism are operating correctly. If the operating mechanism is correct, proceed as follows:—</p> <ol style="list-style-type: none"> (a) Disconnect the spark lead from the piezo unit, then place the stripped end of a suitable piece of insulated wire in the piezo; hold the other end of the wire close to the boiler waterway, then operate the generator and check if a spark is made. If no spark appears, replace the piezo. If a spark is made but it does not spark at electrode: (a) Replace electrode or lead as detailed in Section 7.F or 7.H.
B. Main burner fails to light and pilot is extinguished when pressure on the control knob is released.	<ol style="list-style-type: none"> (1) Control knob not held down long enough. (2) Loose thermocouple connection into control valve. (3) Pilot rate too low. (4) Partially blocked pilot injector. 	<p>Control knob must be fully pressed down for 20 seconds before main valve can be energised.</p> <p>Tighten thermocouple union nut finger tight plus ¼ turn only. Ensure connection is clean and dry. TOO MUCH PRESSURE MAY DAMAGE INSULATION AND CAUSE FAILURE.</p> <p>Adjust the pilot flame, see Section 6.</p> <p>As item A.3.</p>

CONDITION	POSSIBLE CAUSE	REMEDY
	(5) Failure of thermocouple, power unit or latching mechanism.	After pilot has been on for 20 seconds, release control knob. If pilot goes out: (a) Check F.F.D. and thermocouple using procedure given in Fig.15. (b) If thermocouple has failed, replace as described in 7.C. Similarly, if control valve has failed replace as described in 7.D.
C. Main burner fails to light, pilot burning.	(1) Boiler thermostat set to 'OFF' or low setting. (2) Additional controls not calling for heat. (3) S.I.T. control solenoid valve failed. (4) Thermostat out of calibration or faulty (5) Blocked main burner injector.	Note setting of thermostat dial and check temperature of flow pipe. Check programmer or clock is ON and that room thermostat or other distant control is not closed down. Carry out preliminary electrical system checks. Check solenoid using procedure given in Fig.16. If solenoid valve has failed; remove coil securing screws (Fig.12) and fit new coil. Check thermostat using procedure given in Fig. 17. If faulty, replace thermostat as detailed in 7.E. Clean or replace injector as detailed in 7.A.
D. Main burner fails to shut down when water reaches predetermined temperature.	(1) Thermostat out of calibration or faulty. (2) Dirt on valve seat of Honeywell control.	Remedy as in item C(4). Clean the valve seat as follows: (a) Remove the solenoid valve and the plate beneath as described in A(3). (b) Clean the valve seat and the valve chamber. (c) Re-assemble in the reverse order.

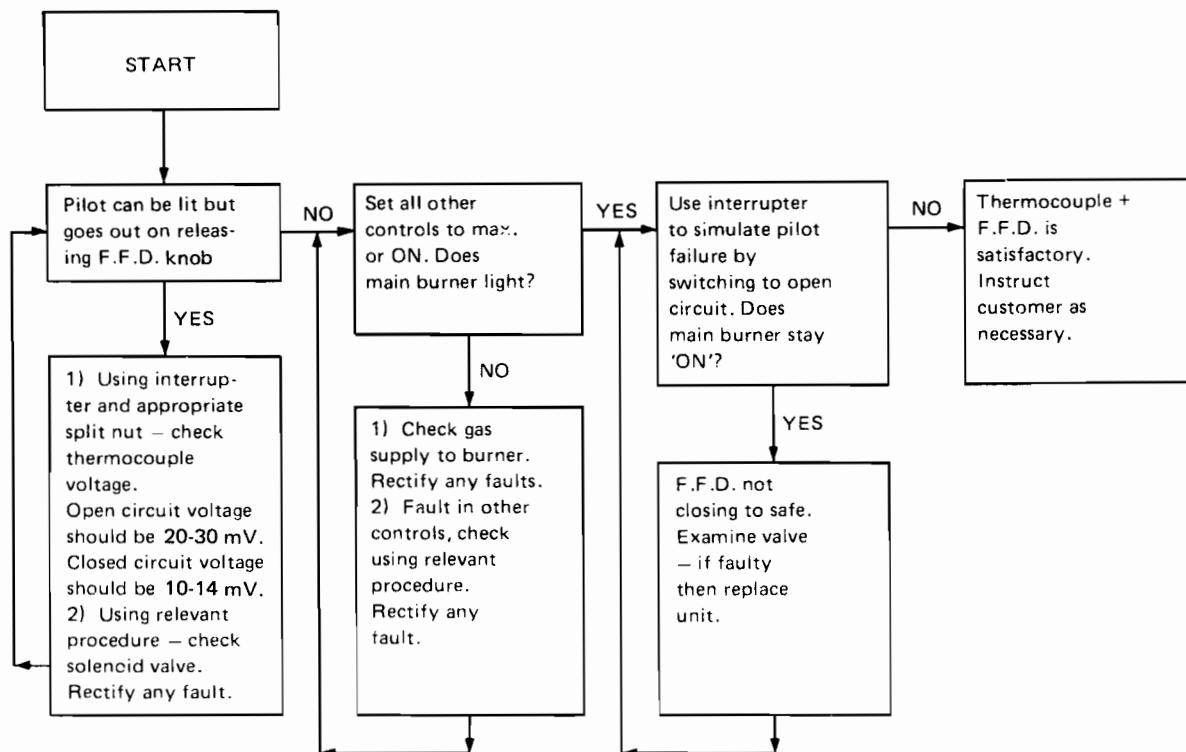

FIG. 15 F.F.D. AND THERMOCOUPLE

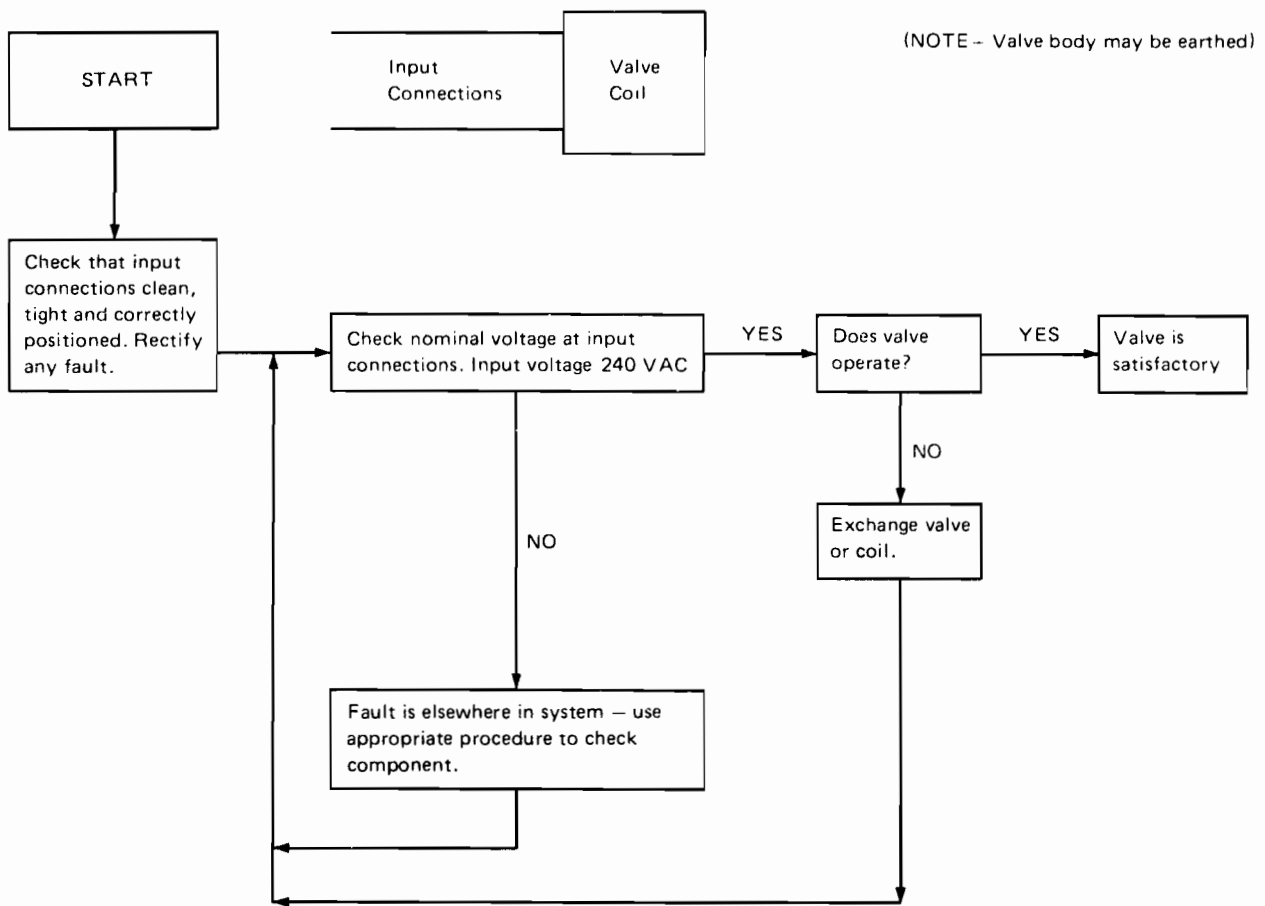

FIG. 16 SOLENOID VALVE

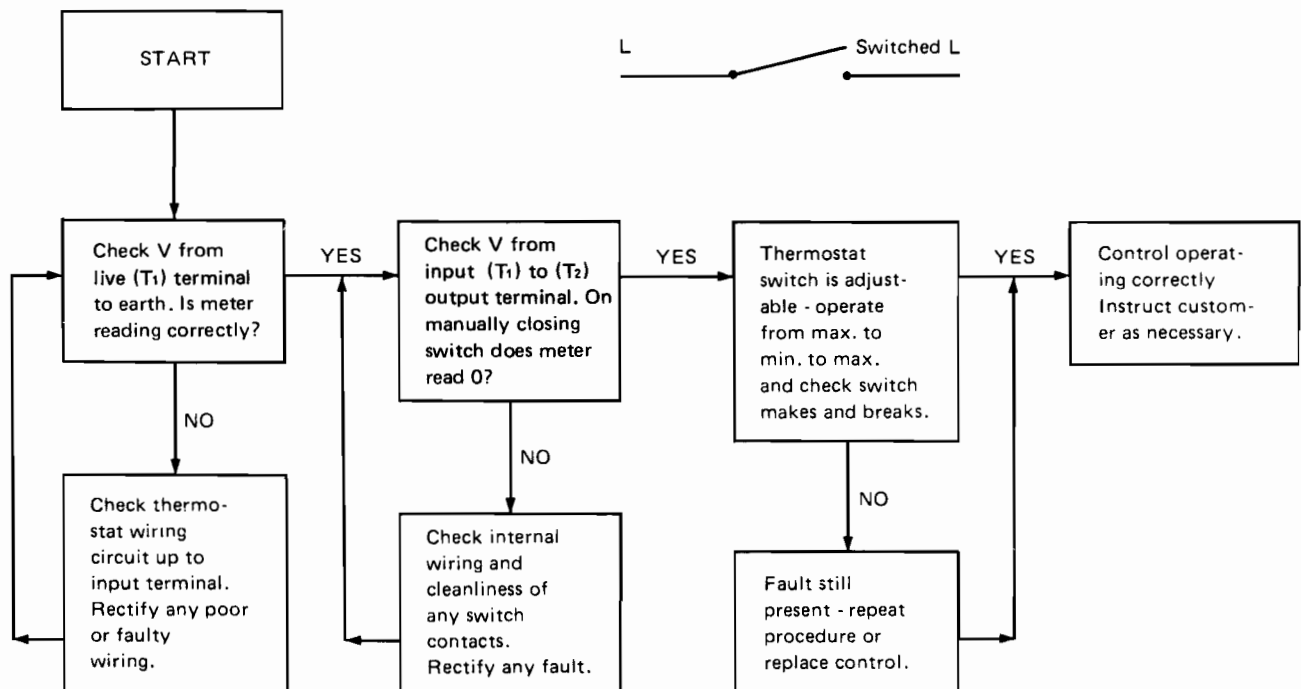
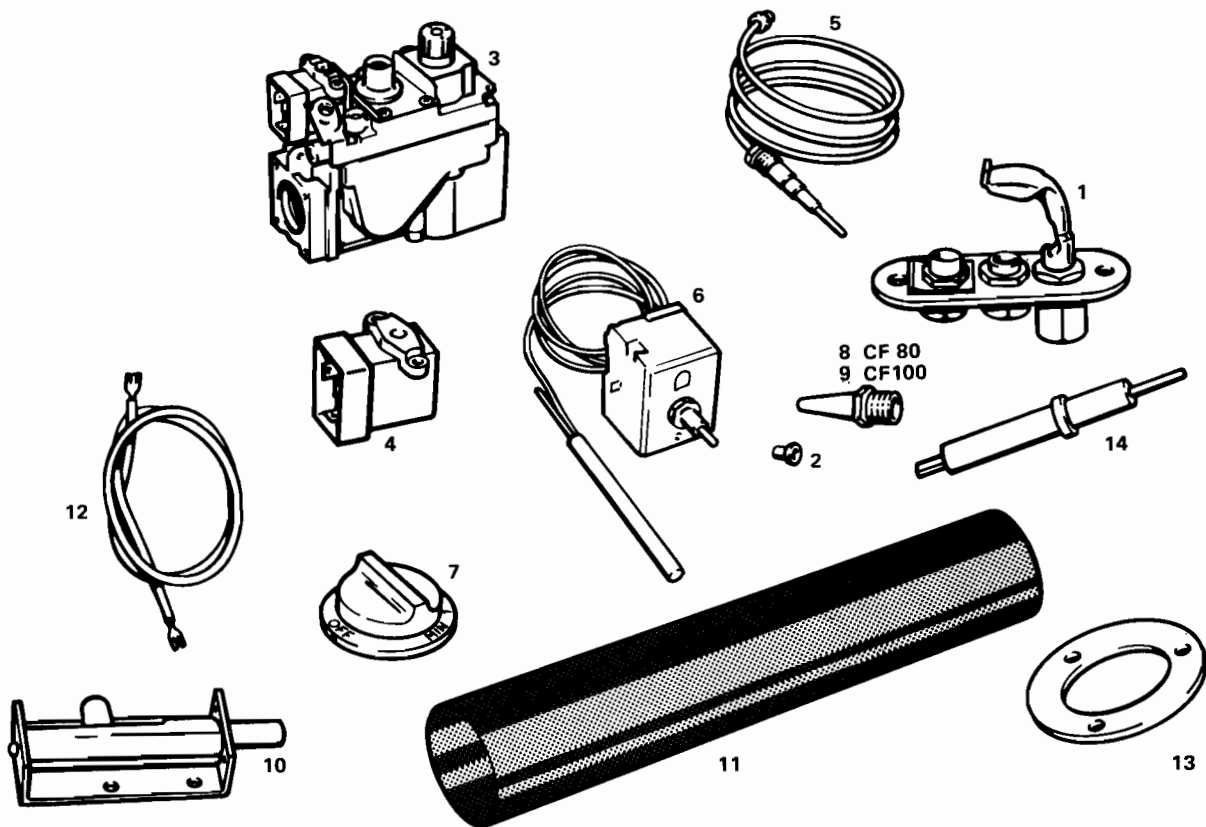

FIG. 17 THERMOSTAT

9. SHORTS PARTS LIST

CF.80 Item No.	CF.100 Item No.	DESCRIPTION	POTTERTON PART No.	BRITISH GAS PART No.
1	1	Pilot Burner, S.I.T. 0.140.012	402893	205208
2	2	Pilot Burner Injector, S.I.T.	402892	395674
3	3	Gas Control Valve, S.I.T. 0.820.010	402906	381627
4	4	Solenoid Operator S.I.T.	907400	381638
5	5	Thermocouple, S.I.T.	402905	381626
6	6	Thermostat Ranco CL6	404486	381628
7	7	Thermostat Knob	206515	381629
8	—	Main Burner Injector 3.1 mm CF.80 2.9 mm CF.100	410908	358 425
—	9		410912	358 607
10	10	Piezo Unit	407623	387951
11	11	Main Burner Lint Resistant Gauze	906155	384 684
12	12	Spark Lead	407665	336405
13	13	Burner End Plate Gasket	905377	358 718
14	14	Spark Electrode, S.I.T.	402885	395 677



"All descriptions and illustrations contained in this leaflet have been carefully prepared but we reserve the right to make changes and improvements in our products which may affect the accuracy of the information contained in this leaflet"

Potterton International Limited	Portobello Works, Emscote Road, Warwick	0926-493420
Northern/Scottish Regional Service Office	8 The Gills, Otley, Leeds. LS21 2AH	0943-465666
South Western/Midland Regional Service Office	Brooks House, Coventry Road, Warwick. CV34 4LL	0926-496896/7
Southern Regional Service Office	10 Hardwicks Way, London, SW18 4AJ	01-870 4131
Parts Department	Brooks House, Coventry Road, Warwick, CV34 4LL	0926-493471

POTTERTON A member of the
INTERNATIONAL LIMITED



Group of companies

Registered in England No.439502. Registered Office: Portobello Works, Emscote Road, Warwick. CV34 5QU.
Sales Office: Brooks House, Coventry Road, Warwick, CV34 4LL. Telephone: 0926-493471.

Publication No. 559105/0286