

Instructions for Use Installation and Servicing

To be left with the user

PROTHERM 60 - 80 CI

G.C. No. 41-047-66

Cat I_{2H}

Fanned Flue Boiler



The mark of quality for domestic heating

Reference in these instructions to British Standards and Statutory Regulations/Requirements apply only to the United Kingdom. For Ireland the rules in force must be used.

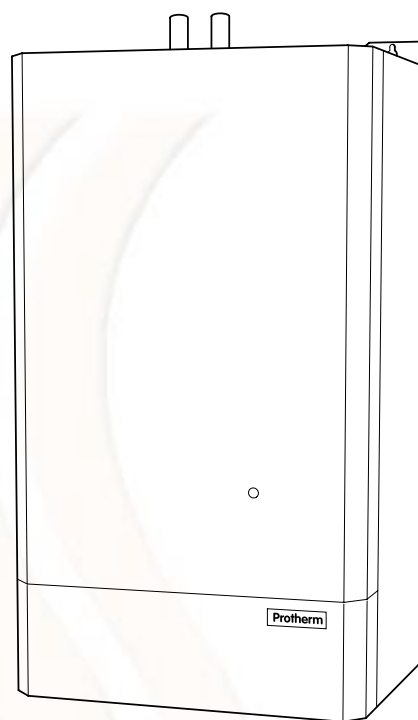

9269

The instructions consist of three parts, User, Installation and Servicing Instructions, which includes the Guarantee Registration Card. The instructions are an integral part of the appliance and must, to comply with the current issue of the Gas Safety (Installation and Use) Regulations, be handed to the user on completion of the installation.

Guarantee Registration

Thank you for installing a new Protherm appliance in your home.

The appliance is manufactured to the very highest standard so we are pleased to offer our customers' a Comprehensive First Year Guarantee.

In the centre pages are to be found your Guarantee Registration Card, which we recommend you complete and return as soon as possible.

If this card is missing you can obtain a copy or record your registration by telephoning the Heatcall Customer Service number 01773 828100.

Our Guarantee gives you peace of mind plus valuable protection against breakdown by covering the cost of:

- All replacement parts**
- All labour charges**
- All call-out charges**

REGISTER YOUR APPLIANCE
FOR 1ST YEAR GUARANTEE PROTECTION

CALL 0208 247 9857

HEATCALL

Customer Services:

Tel: (01773) 828100

One Contact Local Service Fax: (01773) 828070

Important Information

Testing and Certification

This boiler is tested and certificated for safety and performance. It is therefore important that no alteration is made to the boiler, without permission, in writing, from Hepworth Heating Ltd.

Any alteration not approved by Hepworth Heating Ltd., could invalidate the certification, boiler warranty and may also infringe the current issue of the Statutory Requirements, see Section 1.4.

CE Mark

This boiler meets the requirements of Statutory Instrument No. 3083 The boiler (Efficiency) Regulations, and therefore is deemed to meet the requirements of Directive 92/42/EEC on the efficiency requirements for new hot water boilers fired with liquid or gaseous fuels.

Type test for purposes of Regulation 5 certified by: Notified body 0086.

Product/productioncertifiedby: Notified body 0086.

The CE mark on this appliance shows compliance with:

1. Directive 90/396/EEC on the approximation of the laws of the Member States relating to appliances burning gaseous fuels.
2. Directive 73/23/EEC on the harmonization of the Laws of the Member States relating to the electrical equipment designed for use within certain voltage limits.
3. Directive 89/336/EEC on the approximation of the Laws of the Member States relating to electromagnetic compatibility.

INFORMATION FOR THE INSTALLER AND SERVICE ENGINEER.

Under Section 6 of The Health and Safety at Work Act 1974, we are required to provide information on substances hazardous to health.

CERAMIC FIBRE/INSULATION PADS.

These can cause irritation to skin, eyes and the respiratory tract. If you have a history of skin complaint you may be susceptible to irritation. High dust levels are usual only if the material is broken. Normal handling should not cause discomfort, but follow normal good hygiene and wash your hands before eating, drinking or going to the lavatory. If you do suffer irritation of the eyes or severe irritation to the skin seek medical attention.

THERMOSTATS

These contain very small amounts of xylene in the sealed phial and capillary. If broken, under normal circumstances the fluid does not cause a problem, but in case of skin contact, wash with cold water. If swallowed drink plenty of water and seek medical attention.

CUT-OFF DEVICES

These contain activated charcoal and a very small amount of chlorodifluormethane in the sealed phial and capillary. If broken, under normal circumstances the fluid does not cause a problem. If there is irritation to the eyes or skin then seek medical attention.

SPARE PARTS

REMEMBER, When replacing a part on this appliance, use only spare parts that you can be assured conform to the safety and performance specification that we require. Do not use reconditioned or copy parts that have not been clearly authorised by Hepworth Heating Ltd.

CONTENTS	DESCRIPTION	SECTION	PAGE No.
INSTRUCTIONS FOR USE	Introduction		3
	Lighting the Boiler		4
INSTALLATION INSTRUCTIONS	General Data	1	5
	Flue & Ventilation	2	8
	Water Systems	3	9
	Flue and Appliance Preparation	4	12
	Boiler Installation	5	18
	Commissioning	6	21
	Instructions to User	7	24
SERVICING INSTRUCTIONS	Servicing	8	24
	Fault Finding	9	26
	Replacement Parts	10	31
	Spare Parts	11	35

Instructions for Use

Introduction

WARNING. It is important that the case (not the controls cover) is not disturbed or removed other than for servicing by a competent person.

Please read these instructions and follow them carefully for the safe and economical use of your boiler.

The Protherm CI series are fanned flue boilers designed to provide central heating and indirect domestic hot water.

The boiler is fully automatic in operation having only one user control, the control thermostat

The Gas Safety (Installation and Use) Regulations

In your interest and that of gas safety it is the law that ALL gas appliances are installed by a competent person in accordance with the above regulations.

Gas Leak or Fault

If a gas leak or fault exists or is suspected, the boiler must be turned off, including the electrical supply and must not be used until the fault has been put right.

Advice/help should be obtained from your installation/servicing company or the local gas undertaking.

Electrical Supply Failure

Failure of the electrical supply will cause the burner to go out. Should this occur, operation of the appliance will normally resume after the electrical supply is restored.

If the boiler does not relight after an electrical supply failure the overheat safety cutoff device may need resetting, remove the controls cover and press the reset button, refer to diagram 1.

Overheat Safety Cutoff

If the overheat safety cutoff device operates on any other occasion than an electrical supply failure, press the reset button as in "Electrical Supply Failure". If the overheat operates again, turn the appliance off and contact your installation/servicing company.

Maintenance

To ensure the continued efficient and safe operation of the boiler it is recommended that it is checked and serviced as necessary at regular intervals. The frequency of servicing will depend upon the particular installation conditions and usage, but in general once a year should be enough.

If this appliance is installed in a rented property there is a duty or care imposed on the owner of the property by the current issue of The Gas Safety (Installation and Use) Regulations, Section 35.

It is the law that any servicing is carried out by a competent person.

To obtain service, please call your installer or Heatcall using the telephone number given on the controls tray.

Please be advised that the 'Benchmark' logbook should be completed by the installation engineer on completion of commissioning and servicing.

All CORGI Registered Installers carry a CORGI ID card, and have a registration number. Both should be recorded in your boiler Logbook. You can check your installer is CORGI registered by calling CORGI direct on :- 01256 372300.

Boiler Clearances

If fixtures are positioned close to the boiler space must be left as shown in diagram 2. At least a minimum clearance of 500mm must be left in front of the boiler to allow for servicing.

Boilers Installed in a Compartment or Cupboard

If the boiler is installed in a compartment or cupboard do not obstruct any ventilation openings.

Do not use the compartment or cupboard for storage.

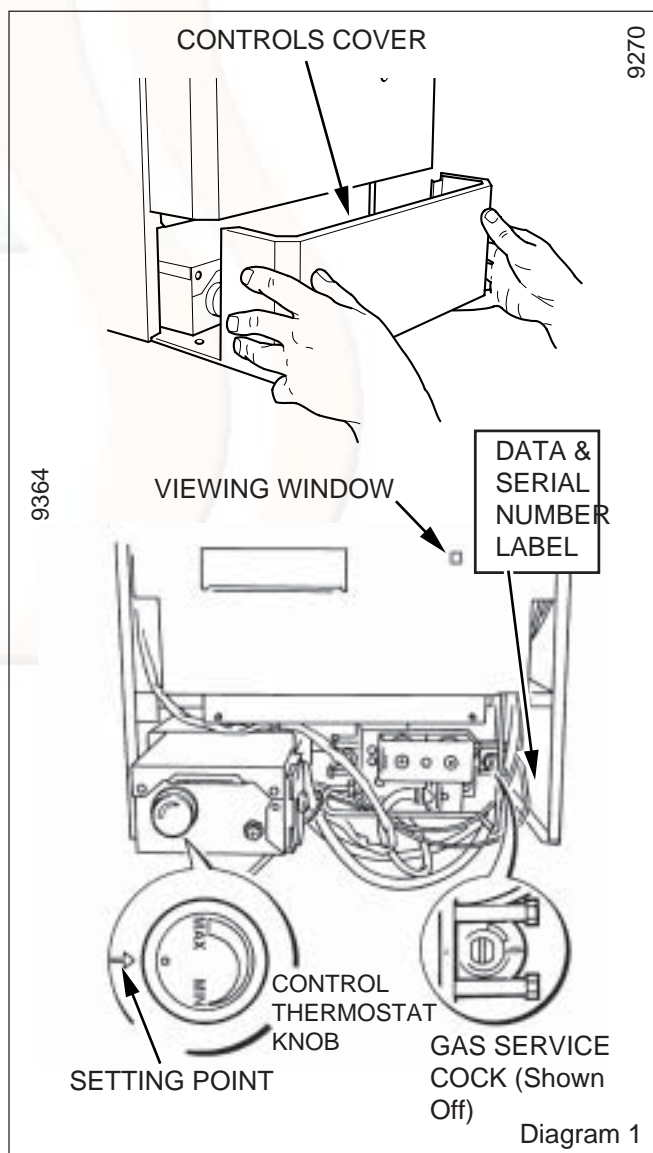

Instructions for Use

Cleaning

WARNING. This appliance contains metal parts (components) and care should be taken when handling and cleaning, with particular regard to edges.

Clean the casing occasionally by wiping it over with a damp cloth or dry polishing duster.

Do not use an abrasive cleaner.

Boiler Electrical Supply

WARNING. This boiler must be earthed.

The boiler must only be connected to a 230V~50Hz supply protected by a 3A fuse.

All wiring must be in accordance with the current issue of BS7671.

Wiring to the boiler must be PVC insulated type to the current issue of BS6500 Table 16, not less than 0.75mm² (24/0.20mm).

The colours of three core flexible cable are:

Brown - live, Blue - neutral,

Green/yellow - earth.

As the markings on your plug may not correspond with these colours continue as follows:

The cable coloured blue must be connected to the terminal marked "N" or black.

The cable coloured brown must be connected to the terminal marked "L" or red.

The cable coloured green/yellow must be connected to the terminal marked "E", or green or the earth symbol \perp .

To Light the Boiler

WARNING. Sealed Systems

A sealed water system must be filled and pressurised by a competent person.

Only light the boiler when you are sure that the system has been filled and pressurised.

The pressure gauge should show at least 0.7bar, anything less than this figure could indicate a leak and you **MUST** contact your installation/servicing company.

If there is any doubt about the boiler being full of water consult your installation/servicing company.

ALL SYSTEMS.

Turn the electrical supply on to the boiler and check that all remote controls are calling for heat.

To Turn the Boiler On

Open the controls cover door, by pulling it forward and down, see diagram 1.

Turn the control thermostat knob clockwise to any position between MIN and MAX. The maximum temperature setting is about 82°C (180°F), see diagram 1.

The boiler lighting operation is now automatic as follows.

The fan operates, followed by an ignition spark until the pilot is lit. When the pilot is alight the ignition system switches off and the main burner lights. The flames can be seen through the viewing window, see diagram 1.

The main burner will remain alight until switched off by the control thermostat or any remote control.

If the boiler is switched OFF, by hand, wait at least 30 seconds before switching on again.

When the boiler switches off, both the pilot and main burner go out.

The automatic lighting sequence will operate again when heat is required.

Shut the controls cover.

It should be noted that this is a fan flue appliance and fan operation may be heard.

To Turn the Boiler Off

For short periods, turn the control thermostat knob anti-clockwise to "O" Off. To relight, turn the control thermostat knob to any position between "MIN" and "MAX".

For longer periods, turn the control thermostat knob fully anti-clockwise to "O" Off and switch off the electrical supply to the boiler.

To relight follow the lighting sequence given above.

Protection Against Freezing.

If the boiler is to be out of use for any long period of time during severe weather conditions we recommend that the whole of the system, including the boiler, be drained off to avoid the risk of freezing up. Make sure that, if fitted, the immersion heater in the cylinder is switched off.

For the position of the serial number, see diagram 1.

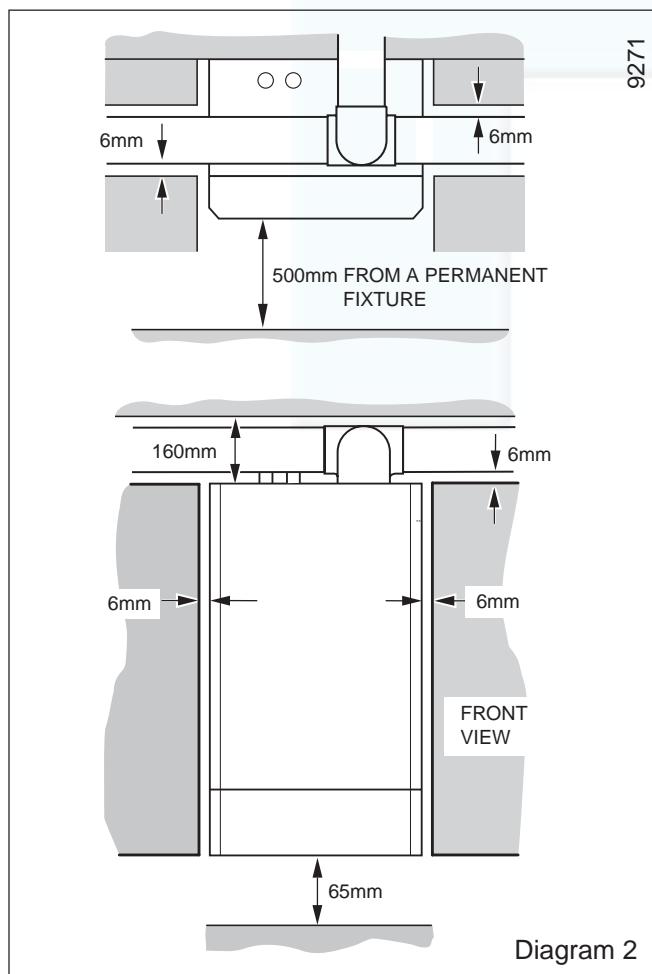

1 General Data

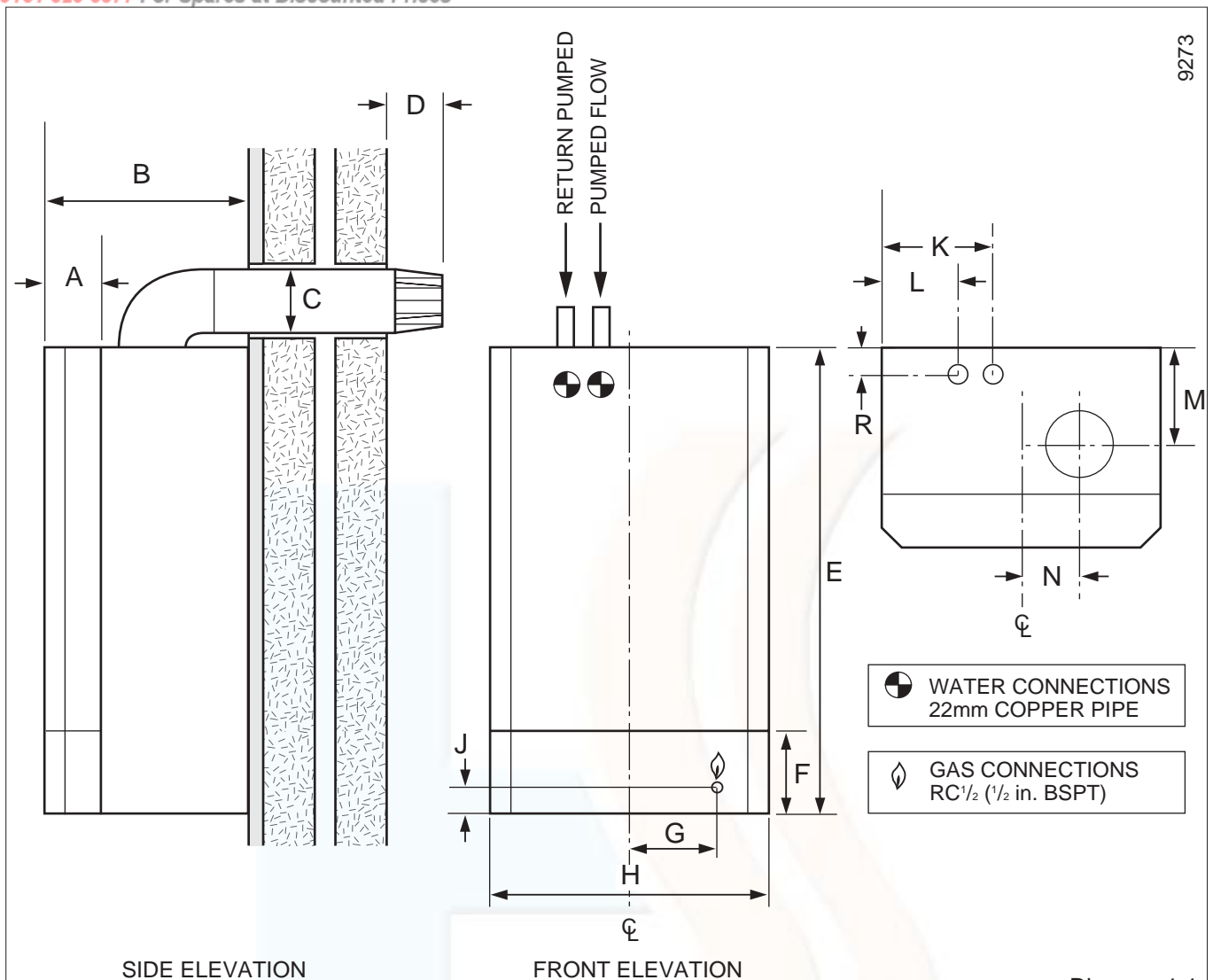

Diagram 1.1

A	B	C	D	E	F	G	H	J	K	L	M	N			
80	300	100	75	700	124	130	400	60	162	110	142	90			

Important Notice

This boiler is for use only on G20 gas.

This boiler can be used on open vented or sealed water systems.

When used on an open vented system domestic hot water can only be provided by a pumped primary circulation.

Wherever possible, all material, appliances and components used shall comply with requirements of applicable British Standards.

Where no British Standards exist, materials and equipment should be fit for their purpose and of suitable quality and workmanship.

Sheet Metal Parts

WARNING. When installing or servicing this boiler care should be taken when handling sheet metal parts, to avoid any possibility of personal injury.

1.1 Statutory Requirements

The installation of the boiler must be carried out by a competent person in accordance with the relevant requirements of the current issue of:-

- The manufacturer's instructions, supplied.
- The Gas Safety (Installation and Use) Regulations, The Building Regulations, Local Water Company Byelaws, The Health and Safety at Work Act, Control of Substances Hazardous to Health, The Electricity at Work Regulations and any local regulations which may apply.

Detailed recommendations are contained in the current issue of the following British Standards and Codes of Practice:-

BS4814, BS6798, BS5440 Part 1 and 2, BS5546 Part 1, BS5449, BS6891, BS6700, BS7074 Part 1 and 2, BS7593, BS7671.

Manufacturer's instructions must not be taken as overriding statutory requirements

1 General Data

1.2 Data

See Table 1 and diagram 1.1.

All dimensions are given in millimetres (except as noted).

The Seasonal Efficiency Domestic Boilers UK (SEDBUK) is 78.1%.

The value is used in the UK Government's Standard Assessment Procedure (SAP) for energy rating of dwellings. The test data from which it has been calculated have been certified by B.S.I.

1.3 Range Rating

This boiler is range rated and may be adjusted to suit individual system requirements.

See Table 2 and diagram 1.3 for ratings and settings.

1.4 B.S.I. Certification

This boiler is certificated to the current issue of British Standard 6332 Part 1, invoking the current issue of BS5258 Part 1 for performance and safety. It is, therefore, important that no alteration is made to this boiler without permission, in writing, from Hepworth Heating Ltd.

Any alteration that is not approved by Hepworth Heating Ltd., could invalidate the B.S.I. Certification of the boiler, warranty and could infringe the current issue of the Statutory Requirements.

1.5 Gas Supply

The gas installation shall be in accordance with the current issue of BS6891.

The supply from the governed meter must be of adequate size to provide a steady inlet working pressure of 20mbar (8in wg) at the boiler.

On completion test the gas installation for soundness using the pressure drop method and suitable leak detection fluid, purge in accordance with the above standard.

1.6 Electrical Supply

WARNING. This boiler must be earthed.

All system components shall be of an approved type and shall be connected in accordance with the current issue of BS7671 and any applicable local regulations.

Connection of the boiler and system controls to the mains supply must be through a common isolator and must be fused 3A, maximum. This method of connection must be by a fused double pole isolating switch, with a minimum contact separation of 3mm on both poles. The switch should be readily accessible and preferably adjacent to the appliance. It should supply the appliance only and be easily identifiable as so doing.

Alternatively, an unswitched shuttered socket outlet and 3A fused 3 pin plug, both to the current issue of BS1363 may be used provided that they are not used in a room containing a bath or shower.

Wiring to the boiler must be to the current issue of BS6500 Table 16, not less than 0.75mm² (24/0.20mm).

1.7 Contents of Packaging

The boiler is delivered in one pack, refer to Section 4.1 for contents.

1.8 Water System

This boiler may be fitted to an open vented or a sealed water system.

1.9 Drain

System

A drain tap must be provided at the lowest points of the system which will allow the entire system, boiler and hot water cylinder be drained.

Draining taps should be to the current issue of BS2879.

Boiler

A draining point is fitted at the bottom right hand side of the heat exchanger.

Cover controls to avoid water damage.

If required remove the combustion chamber front cover to improve access.

DATA TABLE 1.	
TOTAL DRY WEIGHT (Including Terminal)	53 kg (117 lb)
LIFT WEIGHT	47 kg (103lb)
WATER CONTENT	3.35 litre (0.74 gallon)
GAS CONNECTION	Rc 1/2 in.
ELECTRICITY RATING	71W
	Internal fuse F1 & F2 (F1A)
WATER CONNECTION	2x22mm copper pipes from top of case
ELECTRICITY SUPPLY	230V~50Hz, fused 3A
DATA LABEL	Bottom right hand side of case

TABLE 2.				
RANGE RATING		Min.	Medium	Max.
APPROX. GAS RATE	m ³ /h	2.1	2.4	2.7
	ft ³ /h	74	86	97
BURNER INJECTOR MARKING:		205710		
BURNER INJECTOR SIZE:		4.0 mm		
PILOT INJECTOR MARKING:		7218		

TABLE 3. COMPARTMENT AIR VENTS				
VENTILATION REQUIREMENTS	HIGH LEVEL VENT AREA		LOW LEVEL VENT AREA	
	cm ²	in ²	cm ²	in ²
VENTILATION FROM ROOM OR SPACE	264	41	264	41
VENTILATION FROM OUTSIDE	132	21	132	21

1 General Data

1.10 Safety Valve

A safety valve need not be fitted to an open vented system.

1.11 Location

This boiler is not suitable for outdoor installation.

This boiler may be installed in any room, although particular attention is drawn to the requirements of the current issue of BS7671 with respect to the installation of a boiler in a room containing a bath or shower. The electrical provisions of the Building Standards (Scotland) apply to such installations in Scotland.

The boiler must be mounted on a flat wall which is sufficiently robust to take its total weight.

The boiler may be fitted to a wall made of combustible material.

1.12 Boiler Clearances

Refer to diagram 1.2.

This boiler must be positioned so that at least the minimum operational and servicing clearances are provided.

Additional clearances may be required for installation.

If fixtures are positioned next to the boiler they should be made removable for access to pipework.

At least a minimum of 500mm clearance must be left in front of the boiler for servicing, see diagram 1.2.

1.13 Room Ventilation

The boiler is room sealed and does not require the room or space containing it to have permanent air vents.

1.14 Boilers in a Compartment

Where the installation of the boiler will be in an unusual position, special requirements are needed, the current issue of BS6798 gives detailed guidance on these requirements.

A compartment used to enclose the boiler must be designed and constructed specifically for this purpose. An existing cupboard or compartment modified for the purpose may be used. Details of essential requirements for cupboard or compartment design are given in the current issue of BS6798.

The doorway opening should be of sufficient size to allow for easy removal of the boiler.

Where the boiler is fitted in a cupboard or compartment, permanent high and low level ventilation must be provided. The minimum ventilation areas required are given in Table 3.

1.15 Timber Frame Building

If the boiler is to be installed in a timber frame building it should be fitted in accordance with the Institute of Gas Engineers document IGE/UP/7/1998. If in doubt seek advice from the local gas undertaking or Hepworth Heating Ltd.

1.16 Heating System Controls

The heating system should have installed: a programmer and room thermostat controlling the boiler.

Thermostatic radiator valves may be installed, however they must not be fitted in a room where the room thermostat is located.

Note: For further information, see The Building Regulations 1991 - Conservation of fuel and power, 1995 edition - Appendix G, table 4b.

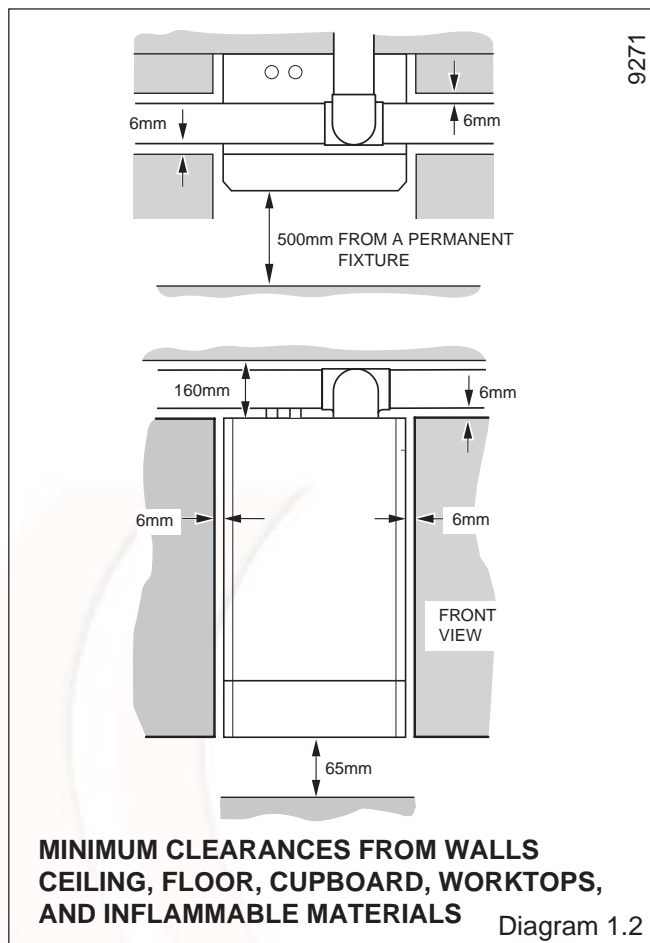

9804

PROTHERM
60-80 CI
HEPWORTH HEATING LTD., BELPER, DERBYS. DE56 1JT

Cat. I_{2H}
EN437

GC No. 41-047-66

Electrical Supply 230V ~ 50Hz 56W Fused at 3A For use on G20 gas only Supply pressure 20 mbar Injector : 4mm 205710		CE 0086		
		GB IE		
		86/AO/007		
RANGE RATING		MIN	MID	MAX
HEAT INPUT	kW	20.27	22.96	25.67
	Btu/h	69090	78350	87620
HEAT OUTPUT	kW	17.58	20.52	23.45
	Btu/h	60000	70000	80000
HOT BURNER PRESSURE	mbar	9.5	12.2	15.2
	in wg	3.8	4.9	6.1

Position ↑ against setting

SERIAL No. 2000462214

Diagram 1.3

2 Flue and Ventilation

Note. Detailed recommendations for flue are given in the current issue of BS5440 Part 1.

2.1 Terminal Position

The minimum acceptable siting dimensions for the terminal from obstructions, other terminals and ventilation openings are shown in diagram 2.1.

The terminal must be exposed to the external air, the position allowing free passage of air across it at all times.

Car ports or similar extensions of a roof only, or a roof and one wall, require special consideration with respect to any openings, doors, vents or windows under the roof. Care is required to protect the roof if it is made of plastic sheeting. If the car port consists of a roof and two or more walls, seek advice from the local gas company before installing the boiler.

If the terminal is fitted within 600mm below plastic guttering or painted soffit an aluminium shield 1500mm long should be fitted immediately beneath the guttering or eaves. If the terminal is fitted within 450mm below painted eaves or a painted gutter, an aluminium shield 750mm long should be fitted immediately beneath the guttering or eaves.

2.2 Terminal Guard

A terminal guard is required if persons could come into contact with the terminal or the terminal could be subject to damage.

If a terminal guard is required, it must be positioned to provide a minimum of 50mm clearance from any part of the terminal and be central over the terminal.

A suitable guard, reference Type "K3", can be obtained from:

Tower Flue Components Ltd
 Morley Road
 Tonbridge
 Kent
 TN9 1RA

2.3 Flue Options

Standard Top Outlet Flue Pack - Pt. No. 230483, supplied with boiler.

1 Metre Extension Kit - Pt. No. 230484.

A flue system up to 3 metres in length can be made by connecting 1 metre extension kits together.

Optional Wall Liner Kit - Pt. No. 900862.

45° Flue Bend Pack - Pt. No. 230485.

90° Flue Bend Pack - Pt. No. 230486.

Vertical Flue Kit - Pt. No. 458115.

2.4 Vertical Balanced Flue System

IMPORTANT NOTE : See Section 4.8 Easi-Vent Vertical Flue Terminal, for Installation requirements and fitting instructions.

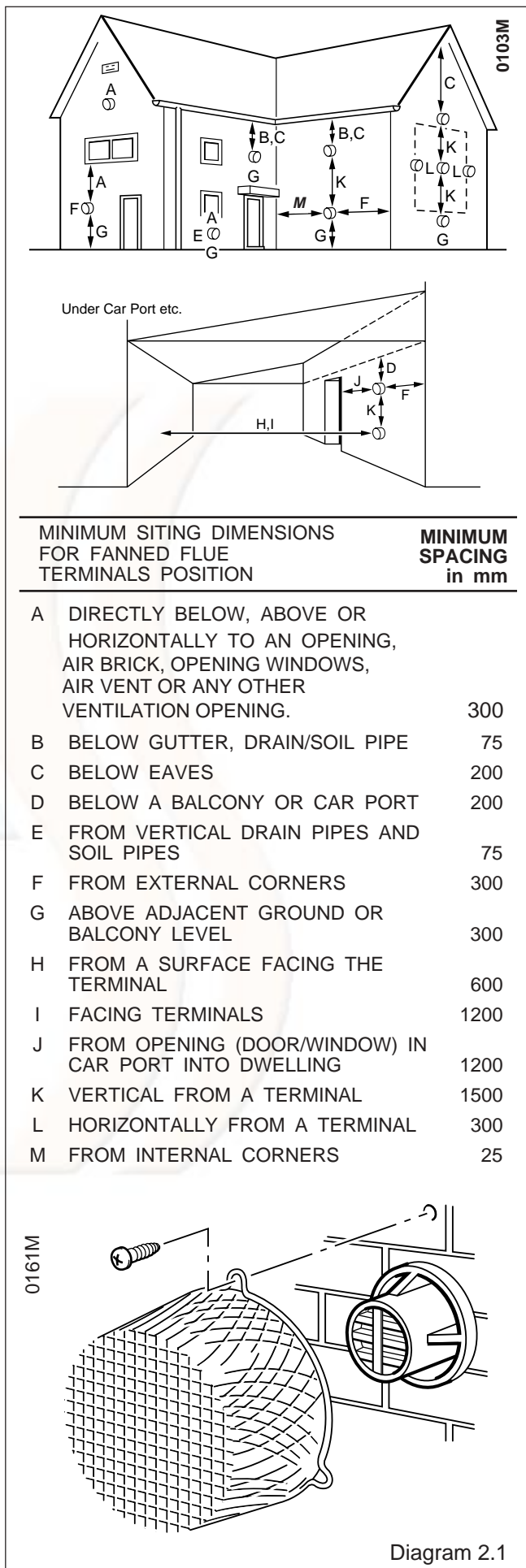

3 Water Systems

The installation of the boiler must comply with the requirements of the current issue of BS6798.

3.1 Frost Protection

If the position of the boiler is such that it may be vulnerable to freezing it should be protected as specified in the current issue of BS5422. It is recommended that a frost protection thermostat be fitted.

3.2 Pump

The pump, with integral valves, should be fitted in the heating flow pipework from the boiler, it should be set to produce a temperature difference of 11°C (20°F) between the flow and return, with the boiler thermostat set at "MAX", which is about 82°C (180°F).

The pressure loss of the boiler can be found from diagram 3.1. High resistance microbore systems may require a higher duty pump.

3.3 Bypass - Fully Pumped and Sealed Water System

A bypass is usually unnecessary on systems using a 3 port diverter valve since one port will remain in the open position at all times. This allows satisfactory operation of the pump overrun.

However if thermostatic radiator valves are fitted to all radiators or two port valves are used a bypass is required.

The bypass connection must be at least 2.5 metres away from the boiler.

The flow through the boiler must not be allowed to fall such that there is a temperature difference greater than 20°C between the flow and return.

3.4 Water System

For an open vented system the boiler must be supplied from an unrestricted water supply taken from a feed and expansion cistern fitted at a maximum height of 27metres above the boiler.

The cold feed must be 15mm minimum size.

It is important that the relative positions of the pump, cold feed and open vent are as shown in diagram 3.2.

The unrestricted open vent from the boiler must rise continuously to discharge over the feed and expansion cistern.

3.5 Domestic Hot Water System

General. The domestic hot water service must be in accordance with the current issue of BS5546, refer also to the current issue of BS6700.

3.6 Cylinder

For all systems supplying domestic hot water the cylinder must be indirect. It is recommended that the cylinder be fitted with some form of temperature control.

3.7 Fully Pumped Domestic Hot Water

The connection for this type of system MUST be as shown in diagram 3.2 and 3.3.

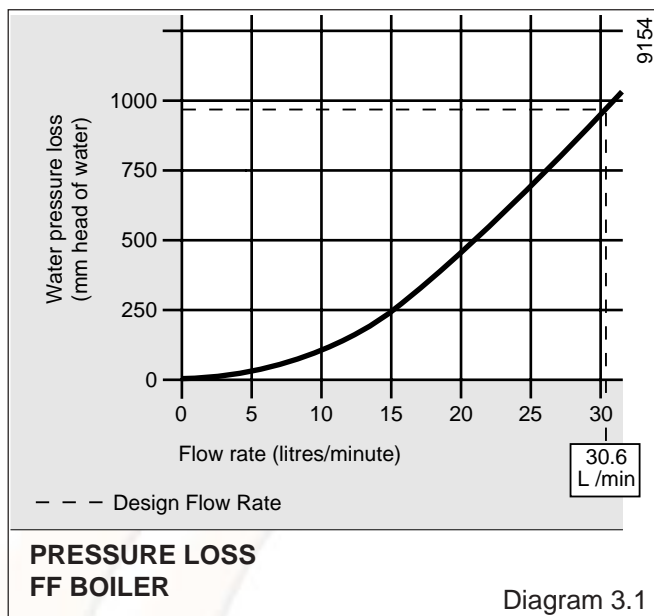

3.8 Inhibitor

Attention is drawn to the current issue of BS5449 and BS7593 on the use of inhibitors in central heating systems.

If an inhibitor is to be used, contact a manufacturer or Hepworth Heating Ltd., for their recommendations as to the best product to use.

When installing in an existing system take special care to drain the entire system, including radiators, then thoroughly cleaning out before installing the boiler whether or not adding an inhibitor.

3.9 Sealed Water Systems

The installation should comply with the appropriate requirements of the current issue of BS4841, BS5449, BS6759, BS6798 and BS7074 Part 1 and 2, see diagram 3.4 for suggested layout.

3.10 Safety Valve

A safety valve must be fitted to a sealed water system.

It shall be preset, nonadjustable with a lift pressure of 3bar, incorporating seating of a resilient material, a test device and a connection for drain.

The drain from the safety valve must be routed clear of any electrical fittings and positioned so that any discharge can be seen.

3 Water Systems

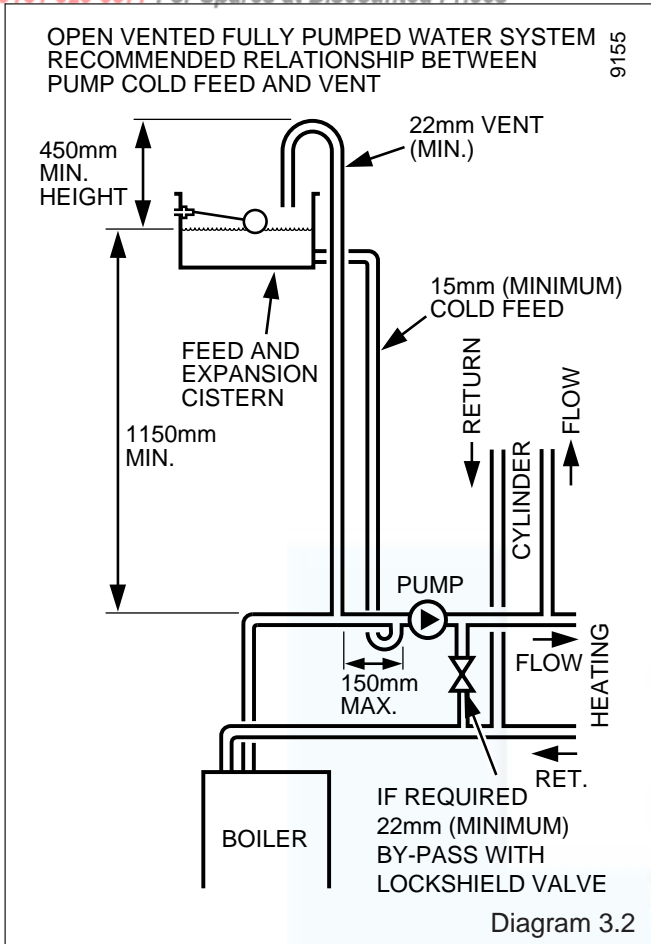

3.11 Expansion Vessel

A diaphragm type expansion vessel, conforming to the current issue of BS4814 (see also BS7404 Part 1 and 2) must be connected at a point close to the inlet side of the circulating pump, see diagram 3.4 unless laid down differently by the manufacturer.

The expansion vessel volume depends upon the total water system volume and the initial system design pressure. For any system an accurate calculation of the vessel size is given in the current issue of BS7074 Part 1.

Example. For an initial system design pressure of 0.7bar the minimum total vessel volume required is $0.063 \times \text{Total System volume}$.

Note. A higher initial design pressure requires a larger volume expansion vessel.

Guidance on vessel sizing is also given in the current issue of BS5449 and BS7074 Part 1.

The charge pressure must not be less than the static head of the system, that is, the height of the highest point of the system above the expansion vessel.

The water content of the boiler is given in Data Table 1.

3.12 Pressure Gauge

A pressure gauge with a set pointer and covering at least the range 0 to 4bar (0 to 60lb/in²) shall be permanently fitted to the system in a position where it can be seen when filling the system.

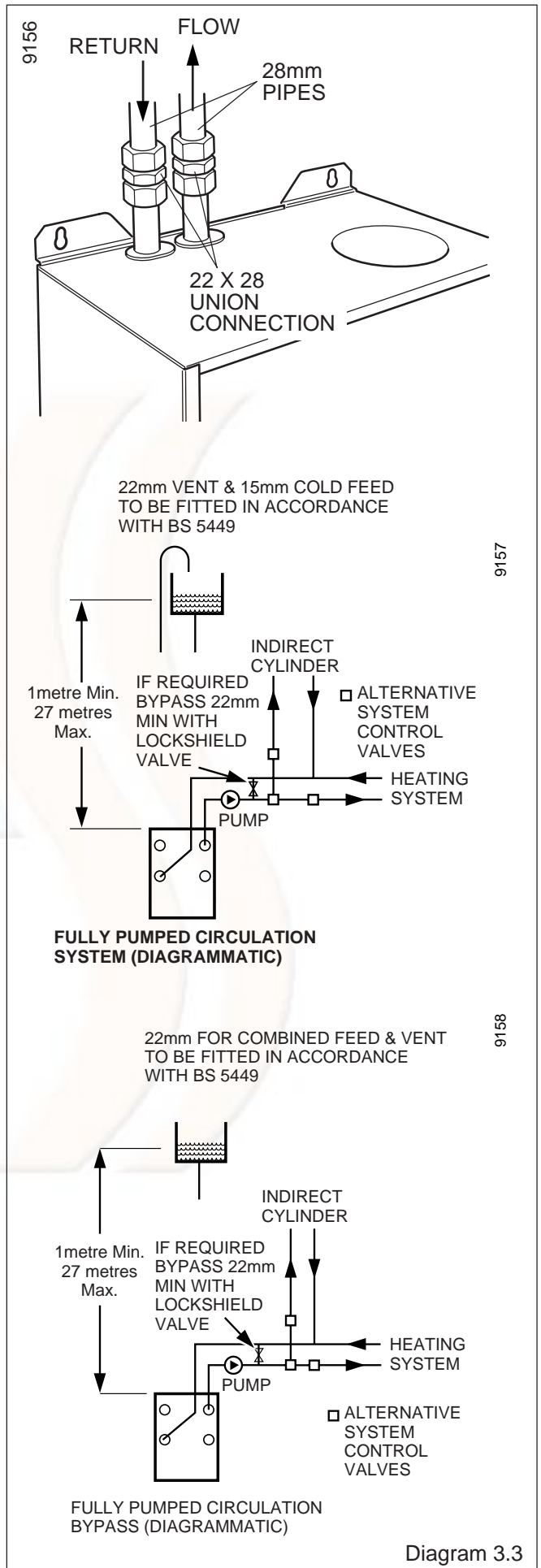

3 Water Systems

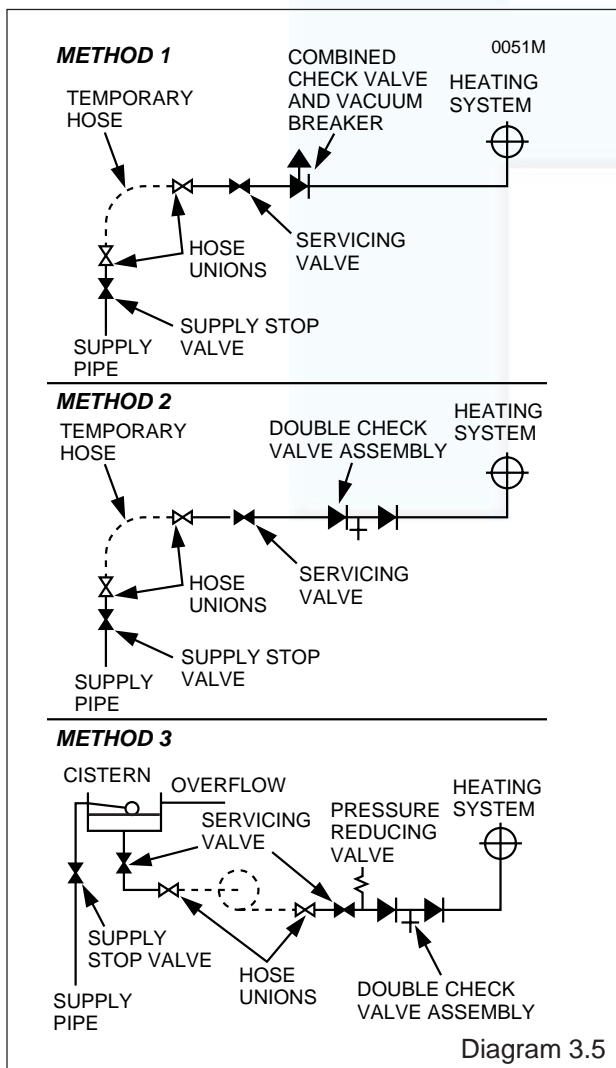
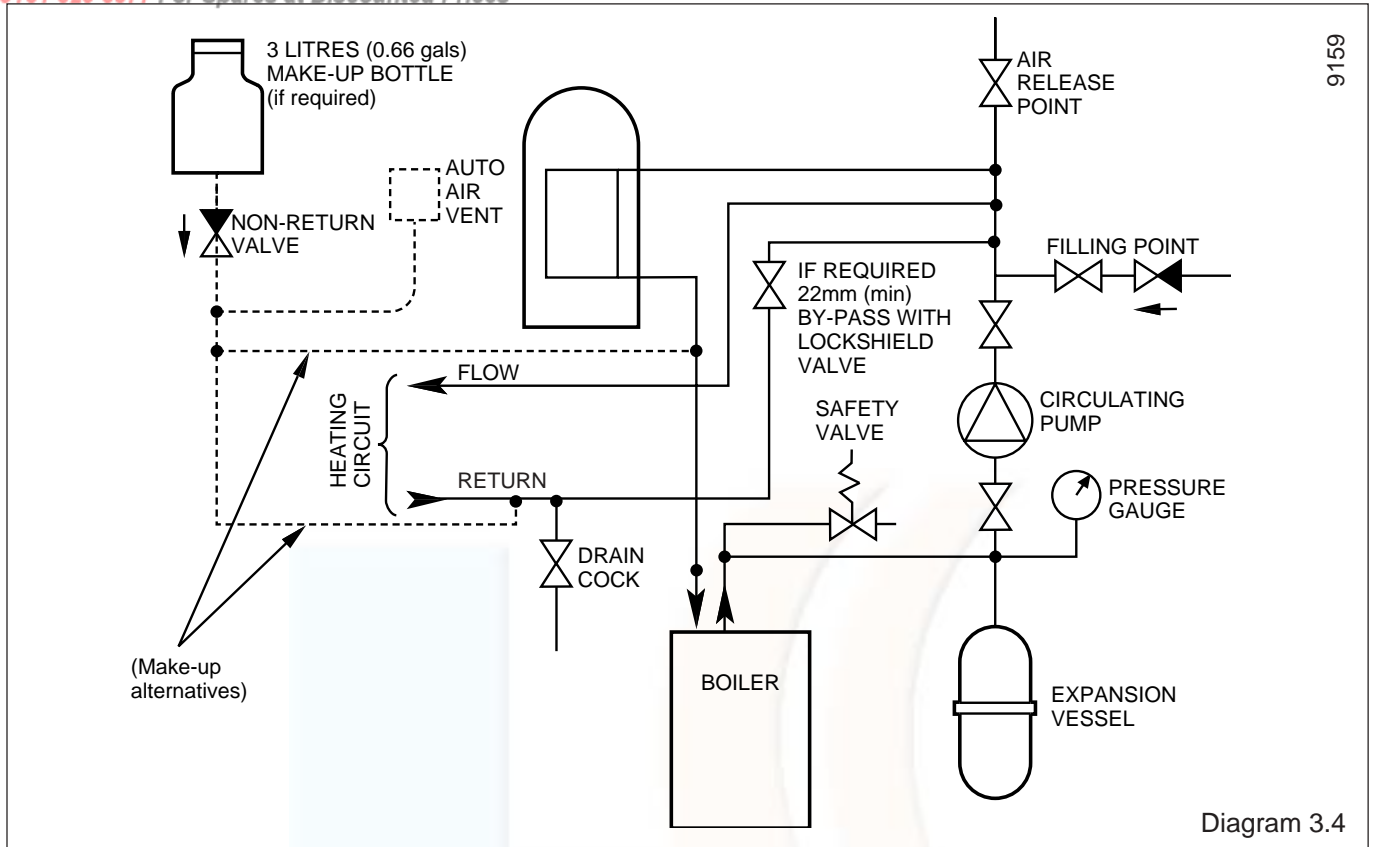

3.13 Domestic Hot Water Cylinder

SINGLE FEED INDIRECT CYLINDERS ARE NOT SUITABLE. The domestic hot water cylinder must be of the indirect coil type. It must be suitable for working at a gauge pressure of 0.35bar above the safety valve setting.

3.14 Domestic Hot Water System - Unvented

Where a storage system will not have a vent to atmosphere the installation must comply with Building Regulations and local Water Company Bye-laws, see also the current issue of BS6700. If fitting into an existing system the local authority must also be advised.

3.15 Filling a Sealed Water System

Provision for filling the system at low level must be made. Three methods are shown in diagram 3.5. There must be no permanent connection to the mains water supply, even through a non-return valve.

3.16 Water Makeup

Provision must be made for replacing water lost from the system. A make up vessel mounted above the highest point of the system and connected through a non-return valve to the system on the return side of either the hot water cylinder or heating system, see diagram 3.4.

Alternatively provision for make up can be made by a filling loop.

4 Flue and Appliance Preparation

9370

STANDARD FLUE PACK

SIDE FLUE

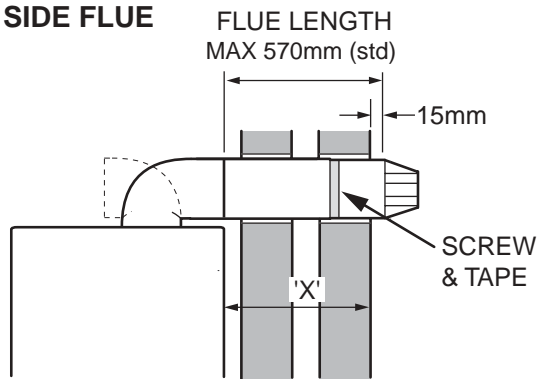

REAR FLUE

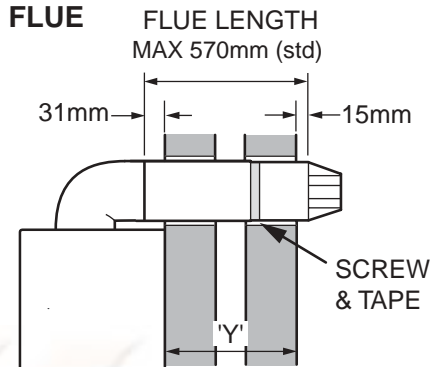

Note: Outer casing, mounting brackets & boiler details removed for clarity

STANDARD FLUE PACK & 1 METRE EXTENSION KIT

Note: 1 metre extension kits can be joined together, but the total flue system must not exceed 3 metres.

SIDE FLUE

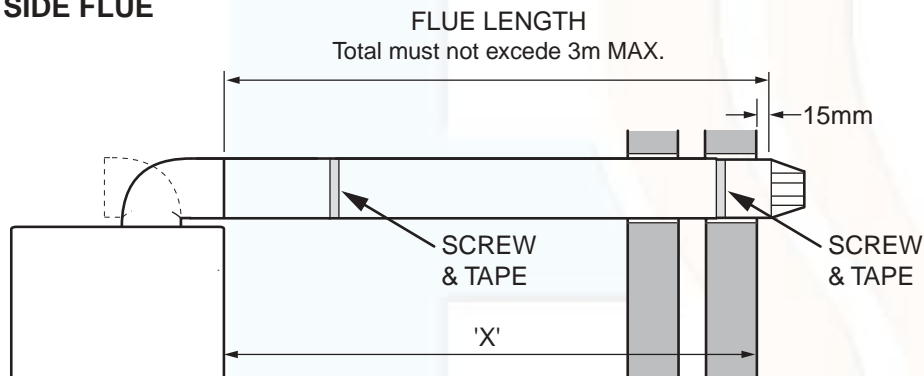

Note: Outer casing, mounting brackets & boiler details removed for clarity

FLUE PACKS	MINIMUM WALL THICKNESS	MINIMUM FLUE LENGTH	MAXIMUM FLUE LENGTH	MAXIMUM DISTANCE FROM	
				"Y" BOILER MOUNTING FACE TO EXTERNAL WALL FACE	"X" BOILER CASING TO EXTERNAL WALL FACE
STANDARD REAR	75	128	570	527	-
SIDE R.H.	75	93	570	-	555
SIDE L.H.	75	273	570	-	372
STANDARD PLUS 1 METRE EXTENSION KITS					
SIDE R.H.	75	-	3000	-	2988
SIDE L.H.	75	-	3000	-	2808

NOTE :

FLUE & AIR DUCT CUTTING

THE DUCTS WILL REQUIRE CUTTING FOR FLUE LENGTHS LESS THAN 280mm.
 THE DUCTS CAN BE CUT FLUSH BUT MUST HAVE AN OVERLAP OF 50mm.

Diagram 4.1

0161 620 6677 For Spares at Discounted Prices

4 Flue and Appliance Preparation

NOTE : Make sure that the ductings do not slope down towards the boiler.

4.1 Flue Position and Length

Determine flue application, length and terminal position before starting.

Refer to diagram 4.1.

4.2 Flue Preparation

All flue assemblies are designed for internal installation, given that there is sufficient clearances opposite to the flue for the installation of the flue.

If there is insufficient clearance the flue can be installed from outside.

For a wall thickness of over 300mm the external flue hole will need to be made good from the outside.

4.3 Top and Side Flue Application

Select the boiler location and flue application, with due regard to the terminal position, see diagram 2.1.

Take the template from the boiler pack and temporarily position it on the wall, making sure that the minimum clearances are maintained, see diagram 4.2.

Mark the centre line position of the flue, as diagram 4.2.

For a side flue, extend centre line of flue to L.H. or R.H. corner. Mark the position of the centre of the flue and boiler, as diagram 4.2.

4.4 Flue Hole Cutting

Having marked out the flue centre cut a hole for the flue using, preferably, a 115mm minimum core drill.

4.5 Wall Mounting Bracket

Reposition the template, making sure of dimensional alignment with the flue hole.

Mark the boiler fixing points and mounting bracket position, see diagram 4.3.

Drill holes and plug, to suit No. 12x2in wood screws, fit the screws allowing sufficient clearance, about 5mm, to allow boiler to be hung.

Secure the mounting bracket to the wall with two No.12x2in wood screws and plugs, see diagram 4.3.

4.6 Flue Duct

Extend the telescopic flue to the required length, making sure that the minimum overlap is no less than 25mm, and that the flue terminal projects 15mm minimum beyond wall face, see diagram 4.1.

Carefully drill through air duct pilot hole and secure with self tapping screw provided in fittings pack, see diagram 4.1.

Seal the joint with the tape provided.

If the boiler is not to be fitted for some time cover the hole in the wall.

4.7 Top, Side Flue Fixing

Make sure that the ductings do not slope down towards the boiler.

Make good the area around the flue inside and outside after installation of the boiler.

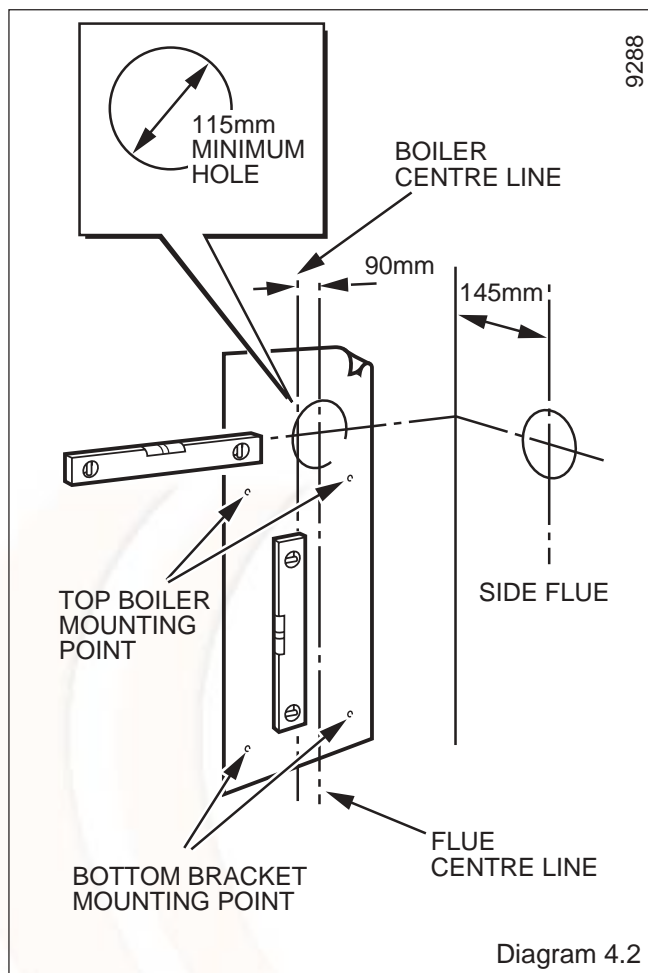

9288

Diagram 4.2

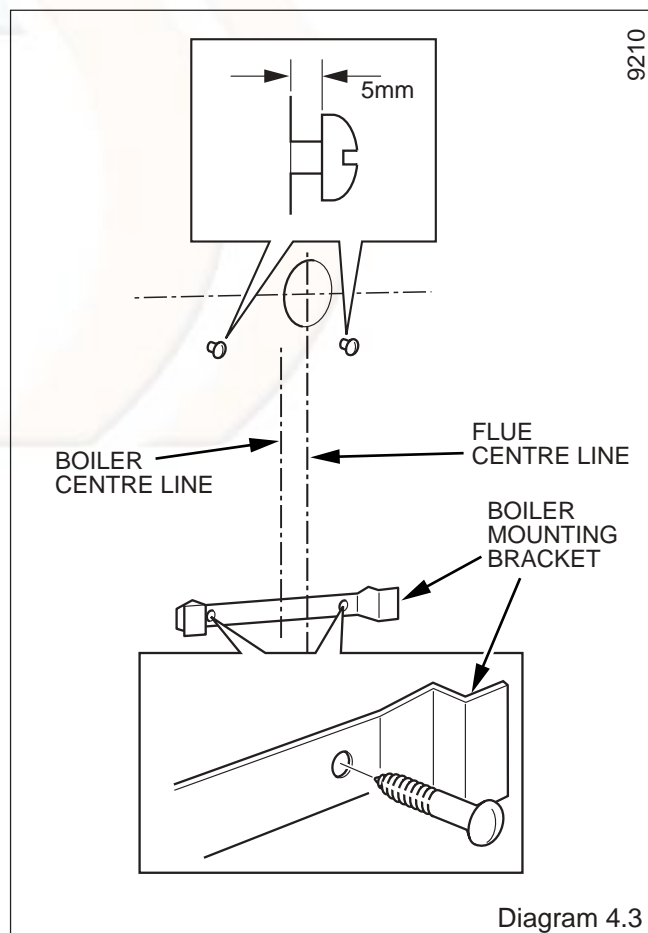

9210

Diagram 4.3

4 Flue and Appliance Preparation

4.8 Easi-Vent Vertical Flue Terminal

General

The kits shown in diagram 4.4, enable the Protherm to be fitted with the flue configurations shown in diagram 4.6.

For other accessories, see diagram 4.5.

Only proprietary parts supplied by Hepworth Heating Ltd. should be used.

4.9 Accessories

Ceiling Collar - Part No. 208590

Used if required as a ceiling trim immediately below the ceiling to make a neat installation.

Fixings are required to hold ceiling collar in position.

Support Assembly - Part No. 208591

Manufactured in galvanised steel and incorporates a fire stop plate with fitted spacer lugs and support collar. This item should be used to support the flue at the top of each floor joist and provide a fire stop feature. Spacer lugs fitted to the underside of the plate ensures that a clearance is maintained between the inner liner of the flue and any combustible materials. The support collar which is situated on the top of the plate should be securely fixed around the flue by tightening the nut and bolt fasteners provided. The plate should be nailed or screwed to the ceiling joists.

Fire Stop Plate - Part No. 208592

Manufactured in galvanised steel and fitted with spacer lugs which ensure that a clearance is maintained between the inner liner of the flue and any combustible materials. The fire stop plate should be fitted to the underside of the ceiling joists by sliding over the flue and nailed or screwed to the joists. This item can act as a dust plate and should be used when the flue system passes through non combustible floors such as concrete.

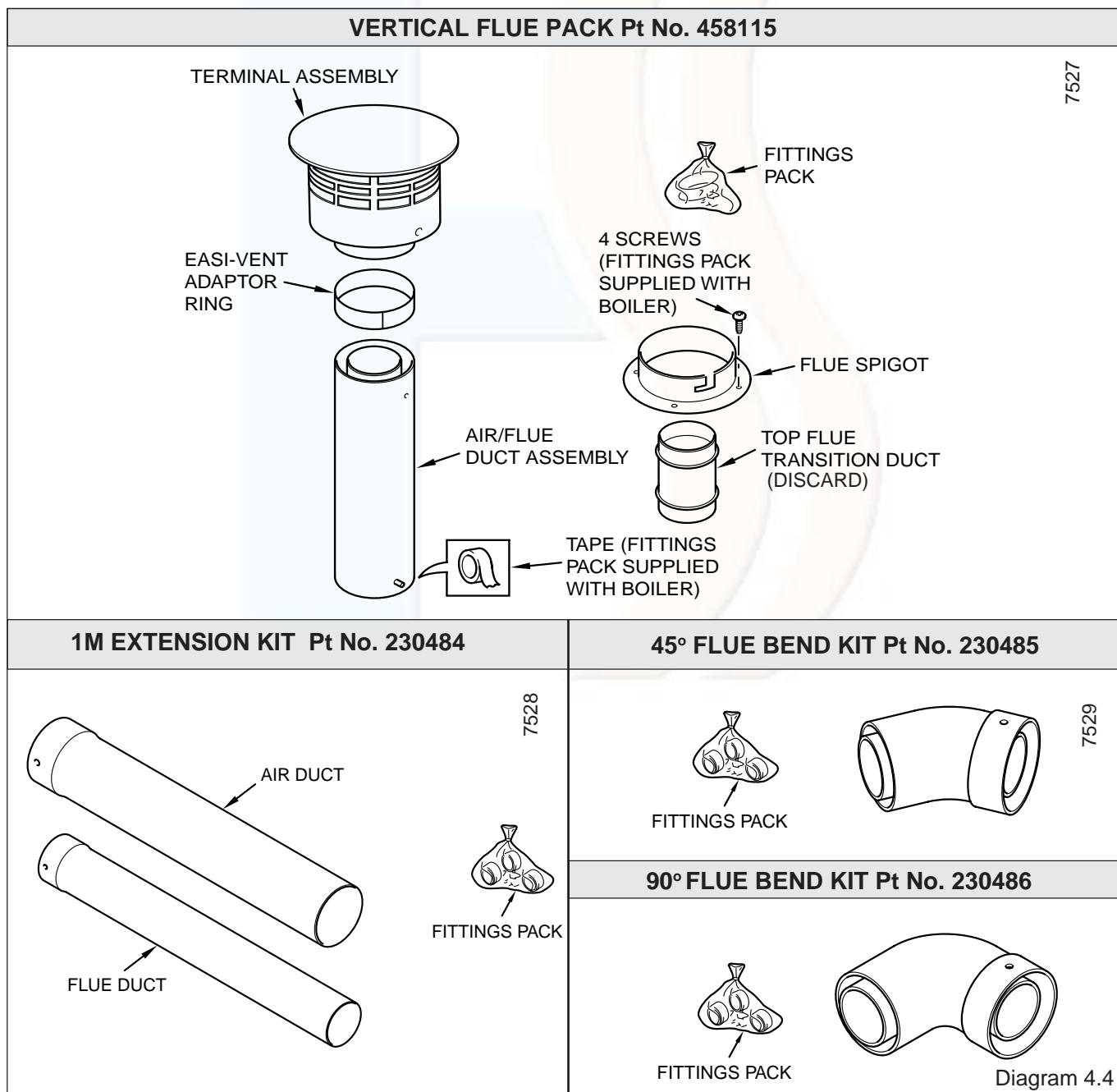

4 Flue and Appliance Preparation

Ceiling Plate - Two Piece - Part No. 208593

Manufactured in galvanised steel and should be used on the underside of floor joists where the flue passes through the floor or roof in a non vertical plane. This item is supplied without spacer lugs and should be nailed or screwed to the underside of the joists.

Adjustable Wall Band - Part No. 208594

The wall bracket is supplied in two parts - an aluminium band which fits tightly around the outside of the flue and a galvanised "T" bracket which is secured to a wall or batten. This item is used where the flue is positioned up to 280mm from a wall or point.

4.10 Flue Terminal Position

Caution

If the flue is to pass through or near combustible material it should be fitted in accordance with the current issue of BS5440 Part 1, which requires a minimum clearance of 25mm from the flue duct.

The minimum clearance from the air duct is 5mm.

The terminal should be positioned so as to cause the least problem with the dispersal of the products of combustion and any "pluming" that can occur.

If the terminal is fitted less than 500mm below plastic gutters or less than 500mm below painted eaves or any other painted surface then an aluminium shield at least 1 metre long should be fitted immediately beneath the guttering or eaves.

Minimum distances for flue to walls and roof positions are shown in diagram 4.6.

Failure to comply with these instructions could result in a potentially dangerous installation and loss of boiler efficiency.

General guidance only can be found in the current issue of BS5440 Part 1.

If in doubt consult Heatcall.

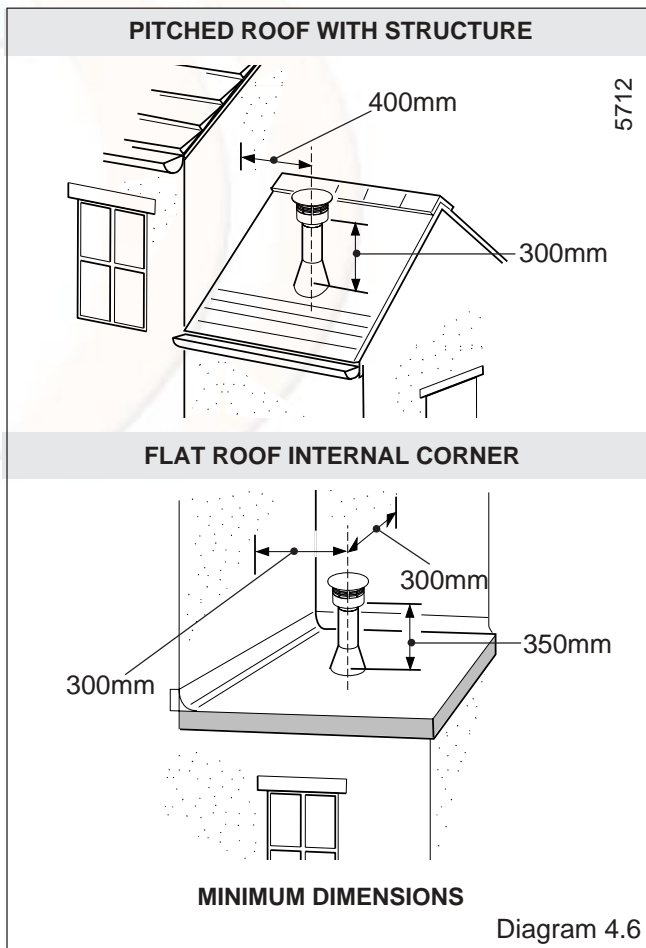
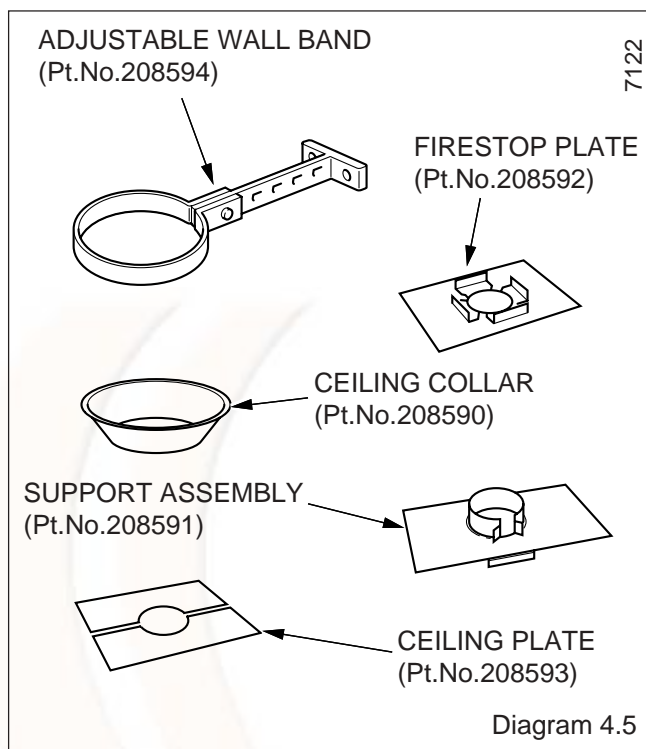

4 Flue and Appliance Preparation

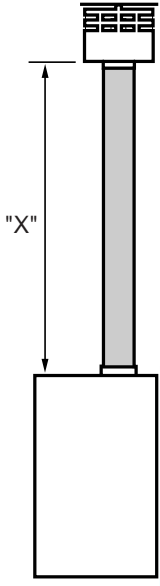
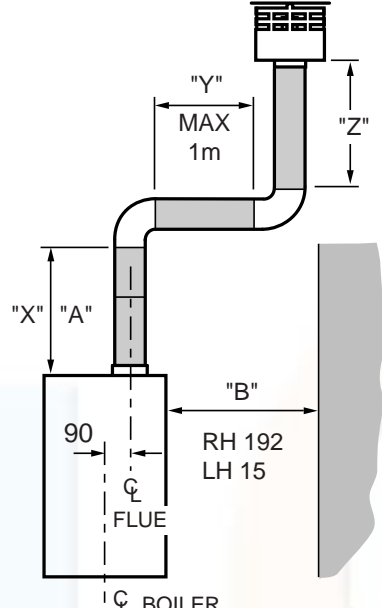
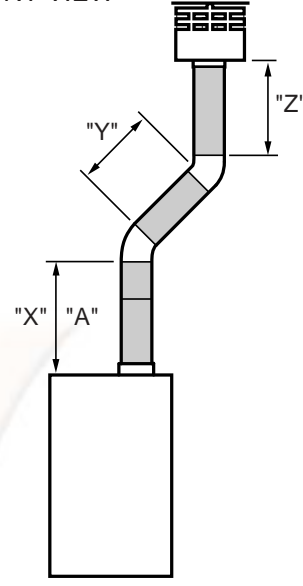
VERTICAL FLUE VERTICAL FLUE KIT 458115 1M EXTENSION KIT 230484 (as reqd.)	HORIZONTAL and VERTICAL FLUE VERTICAL FLUE KIT 458115 1M EXTENSION KIT 230484 (as reqd.) FLUE BEND KIT 90 230486 (2 reqd.)	DIAGONAL and VERTICAL FLUE VERTICAL FLUE KIT 458115 1M EXTENSION KIT 230484 (as reqd.) FLUE BEND KIT 45 230485 (2 reqd.)		
FRONT VIEW 	FRONT VIEW 	FRONT VIEW 		
9551				
Diagram 4.7				
X + Y + Z = THE MAXIMUM STRAIGHT "FLUE LENGTH" DOES NOT INCLUDE THE ELBOWS. NOTE: An Inline Adaptor Pt. No. 230488 with a flue length of 100mm can be used.				
"X" MAX. FLUE LENGTH	X+Y+Z MAX. FLUE LENGTH		X+Y+Z MAX. FLUE LENGTH	
3m	1.5m		2.0m	
"X" MIN. FLUE LENGTH	MINIMUM FLUE LENGTH	MINIMUM INSTALLATION CLEARANCE	MINIMUM FLUE LENGTH	MINIMUM INSTALLATION CLEARANCE
500mm	X 60mm Y ZERO Z 500mm	A 500mm B RH 192mm / LH 15mm	X 60mm Y ZERO Z 500mm	A 500mm B RH 58mm / LH N/A

4.11 Installation

Warning

In the interests of safety and performance, it is essential that the vertical flue system is fitted in strict accordance with these instructions.

Installation Details

With due consideration to flue terminal position, choose the flue application required, shown in diagram 4.7.

The use of weather and storm collars is preferred and can be bought locally.

The suggested flashings are :-

RiteVent or Selkirk along with their appropriate storm collar if required.

Flue Installation and Terminal Assembly

Measure then cut the selected flue arrangement as required ensuring an overlap of 25mm AIR DUCT and 50mm FLUE DUCT.

Make sure that all flue pipes, joints and bends are properly secured and tight, see diagram 4.9 for details.

Fit the split/spacing ring supplied in kit, inside the flue terminal. Locate flue terminal in position on top of flue duct. Drill and secure with 2 no. 8 x 3/8 in. self-tapping screws, see diagram 4.10.

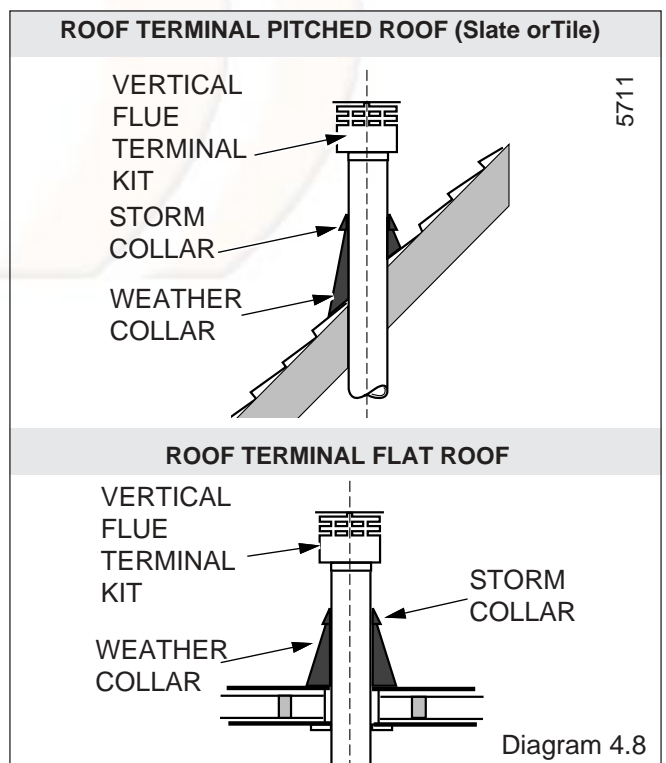

4 Flue and Appliance Preparation

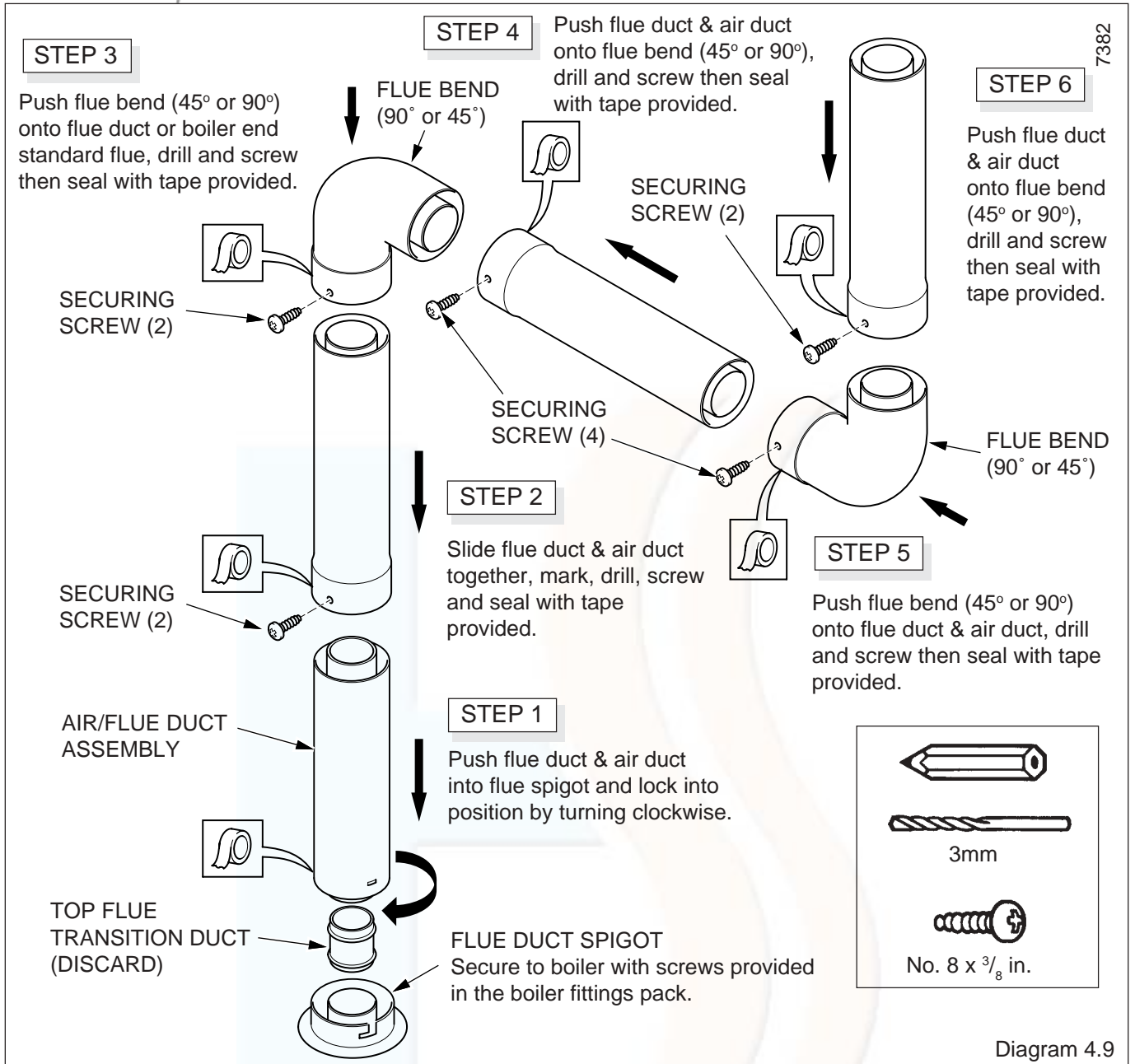

Diagram 4.9

Pitched and Flat Roof

Fit Weather and Storm Collar onto air duct/terminal assembly, see diagram 4.8.

Make sure the weather collar is correctly positioned and sealed for the roof type.

Fit the flue adaptor into flue terminal and connect to air duct.

After the flue terminal is fitted, fit an appropriate wall band.

Make sure that a weather proof seal is made in accordance with good building practice.

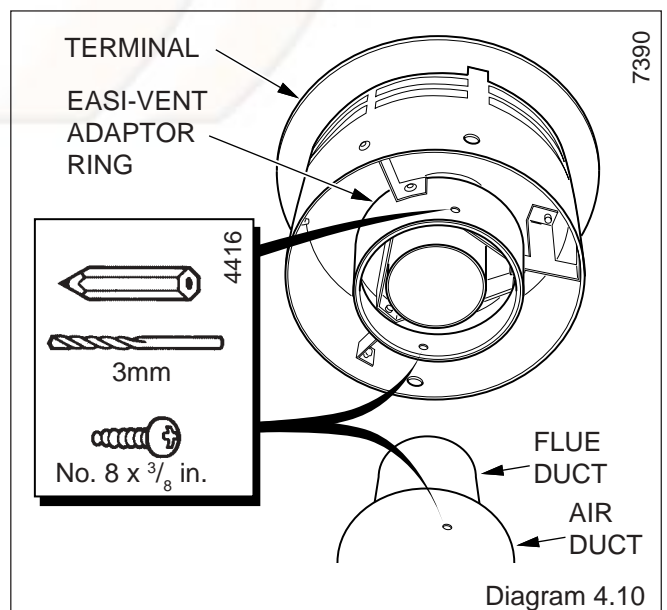

Diagram 4.10

5 Boiler Installation

5.1 Boiler Preparation

Open the carton, check the items supplied against the boiler pack contents list on the carton flap.

With the boiler still in in the bottom tray slide the controls cover upwards and remove, see diagram 5.1.

Remove the front cover by undoing the wing nut, nut and washer, lift the front cover off, see diagram 5.1.

Place controls cover and front cover to one side until required.

Fit suitable compression fittings to the required tapings on the boiler.

Disconnect the air pressure tubes, see diagram 8.1.

Remove the blue and red electrical connections from the fan, see diagram 8.1.

Remove the front right hand flue hood securing screw and slacken off the front left hand one, see diagram 8.3.

Remove fan and flue hood assembly from boiler by drawing assembly forward, place to one side until required.

5.2 Mounting the boiler

Lift the boiler into position ensuring first that the bottom of the boiler is hooked on to the boiler mounting bracket and then engage the two keyhole slots, located on top of the boiler, on to the securing screws. Tighten the two securing screws, see diagram 5.2

Note: Installations where the flue exits to the left of the boiler, complete the water connections to the boiler before fitting the flue.

From the fittings pack, place top turret gasket in position on boiler flue opening, see diagram 5.3

Taking care not to damage the gasket, secure the top turret with flue assembly to the boiler with four self-tap screws, see diagram 5.3.

From the fittings pack, fit flue duct extension assembly into the top turret flue ducting and loosely fit jubilee clip on elbow of the flue duct extension, see diagram 5.4.

Refit fan and flue hood assembly, ensuring that the flue hood fits in the flue hood retaining clamps and engage the fan into the elbow of flue duct extension, see diagram 8.3

Tighten up left hand flue hood securing screw, replace the right hand one and tighten, see diagram 8.3.

Secure fan to elbow of flue duct extension by tightening up jubilee clip, see diagram 5.4.

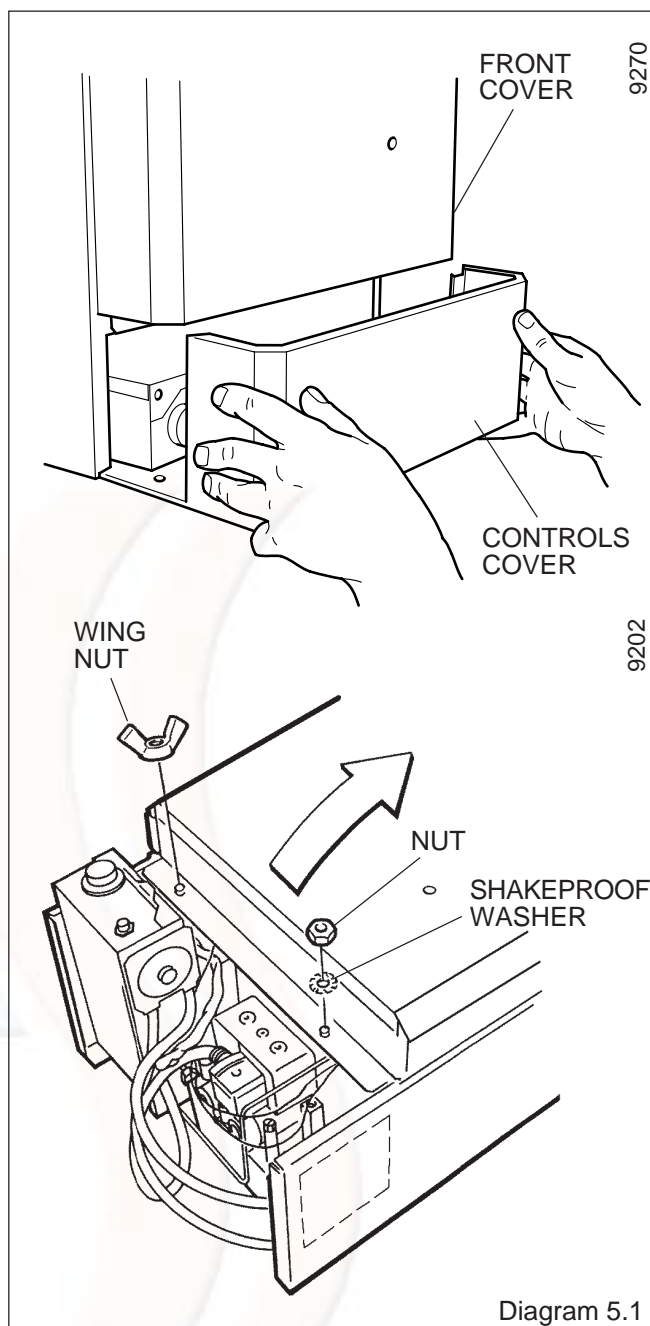

5 Boiler Installation

5.3 Water Circulation System

Complete the water connections to the boiler.

Fill, vent and flush the system.

Check for any water leaks and put right.

5.4 Safety Valve Discharge

Fit a suitable discharge pipe to the safety valve and route it to outside the building so that any discharge can be seen but will not cause injury to persons, damage to property or any electrical installation.

5.5 Gas Connection

Make the gas connection to the Rc $\frac{1}{2}$ in gas service cock, see diagram 6.1.

Check for leaks using a suitable leak detection fluid.

5.6 Control Box Removal

Remove the electrical control box securing screws, see diagram 5.5. Slide the box forwards and release, hook it onto the lip bracket at the front, see diagram 5.5.

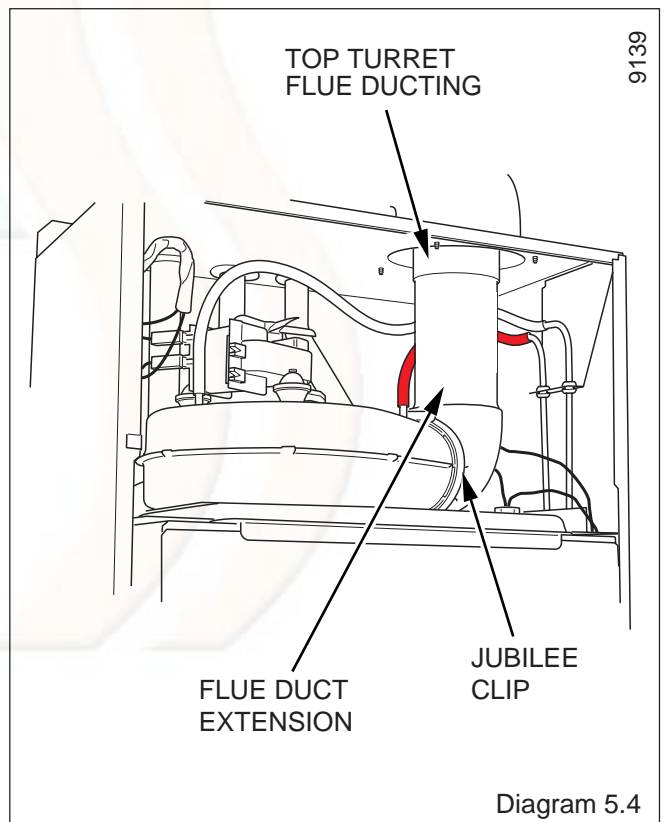
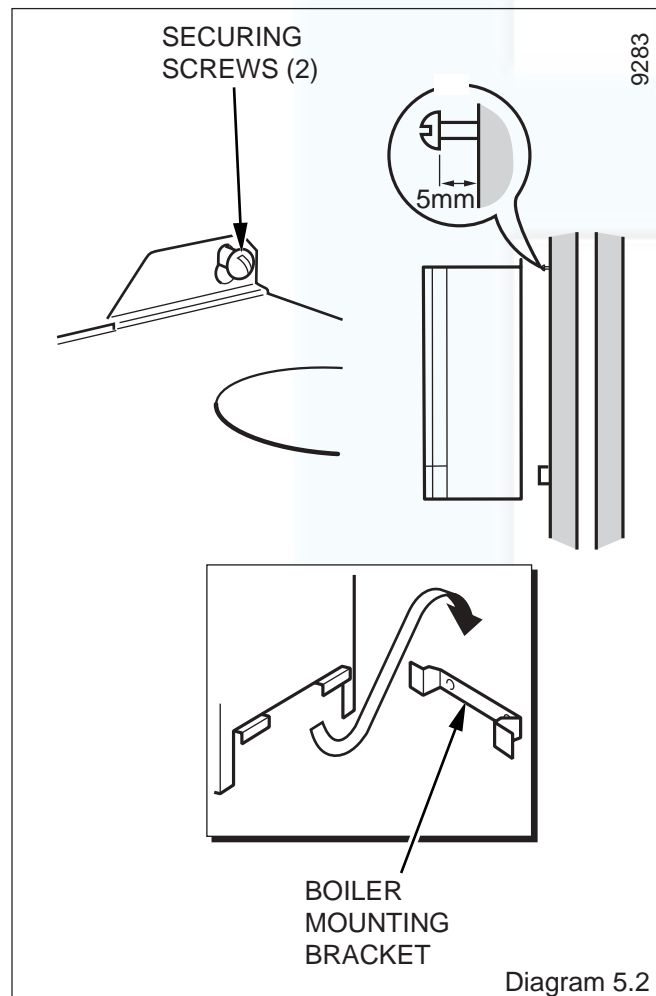
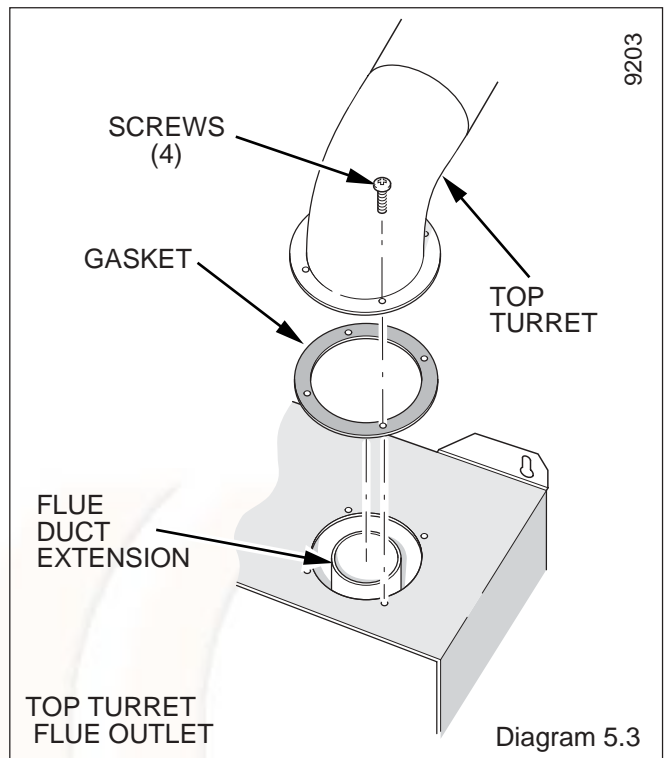

5 Boiler Installation

5.7 Electrical Connection

WARNING. This boiler must be earthed.

Take care not to damage any internal wiring and capillaries.

Take plastic cable retaining clip, from the loose items pack, peel off the backing paper and position it in a suitable place to secure the incoming cable.

Using heat resistant (to 85°C) cable of at least 0.75mm² (24/0.2mm) to the current issue of BS6500 Table 16 and of suitable length, thread through cable clamps, secure into the plastic clips and connect to appropriate terminals, see diagram 5.6 and 9.5.

Standard colours are, brown - live (L), blue - neutral (N) and green and yellow - earth (E).

The mains cable outer insulation must not be cut back external to the cable clamp.

Make sure the cable is suitably secured.

When making connections, make sure that the earth conductor is made of a greater length than the current carrying conductors, so that if the cable is strained the earth conductor would be the last to become disconnected.

5.8 Pump Connection

The pump must be connected directly to the control box, as shown in diagram 5.6 threading the cable through the cable clamp in the side of the control box.

5.9 External Controls

Any external controls must only be wired to interrupt the red link between terminals SL and 9.

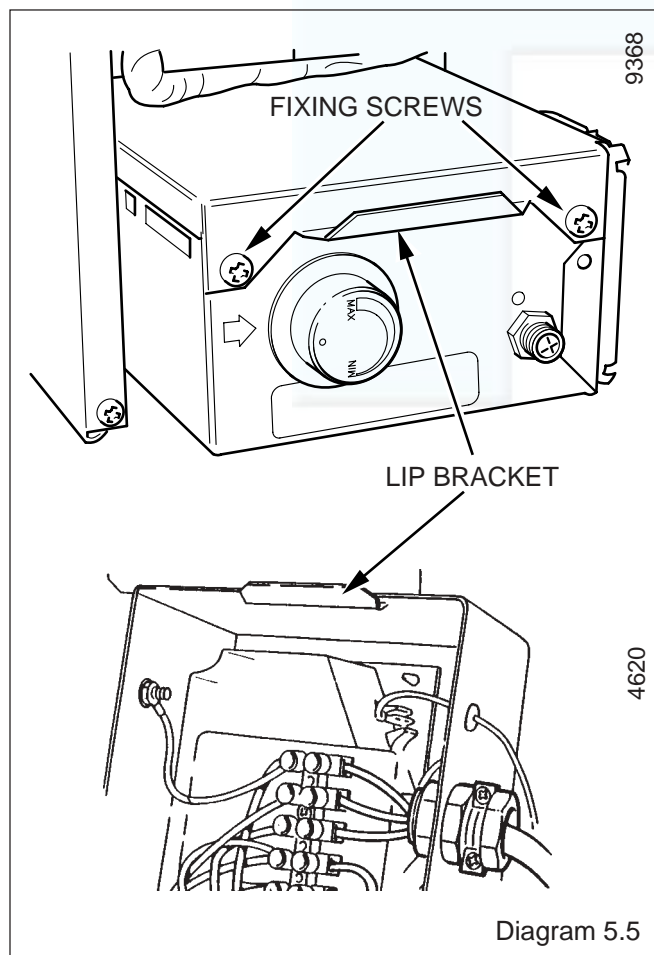

Make sure that the supply cable and all external cables are secured and away from hot surfaces.

5.10 Testing

Checks to ensure electrical safety must be carried out by a competent person.

After installation of the system, preliminary electrical system checks as below should be carried out.

1. Test insulation resistance to earth.
2. Test continuity and short circuit of all cables,
3. Test the polarity of the mains.

The installer is requested to advise and give guidance to the user on the controls scheme used with the boiler.

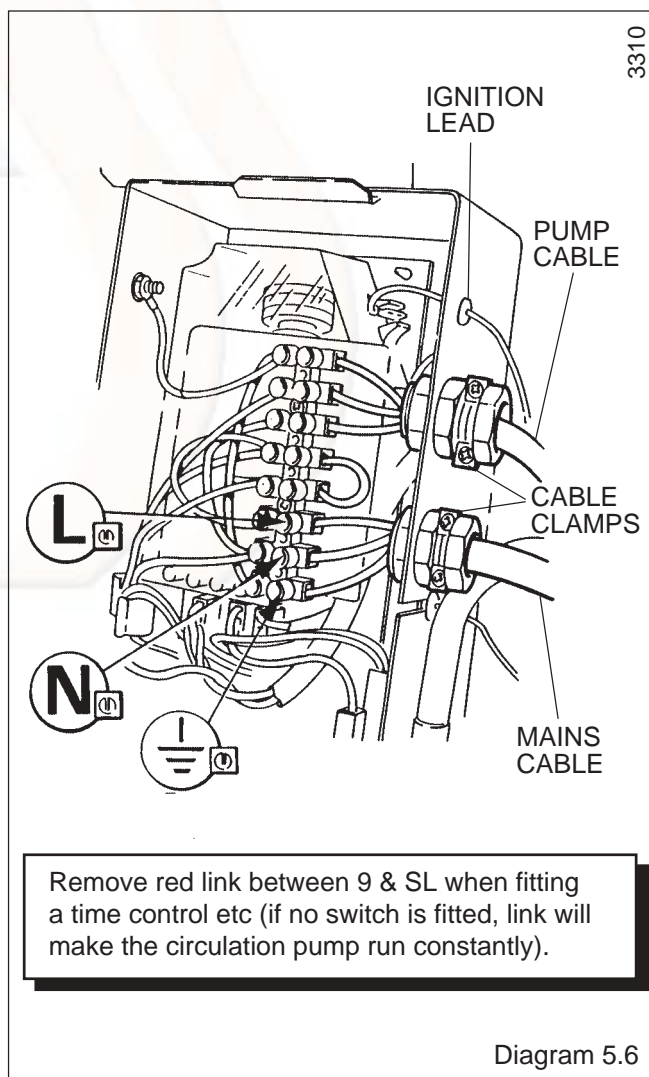

6 Commissioning

Please ensure the "Benchmark" logbook is completed and left with the user.

6.1 All Systems

Commissioning should be carried out by a competent person in accordance with the current issue of BS6798.

Make sure that the system has been thoroughly flushed out with cold water without the pump in place.

Refit the pump, fill the system with water, making sure that all air is properly vented from the system and pump.

Before operating the boiler check that all external controls are calling for heat.

6.2 Sealed Water Systems Only

Flush the whole of the system with cold water without the pump in place. Refit the pump and fill until the pressure gauge registers 2.7bar (40lb/in²). Clear any air locks and check for water soundness.

Check the operation of the safety valve, by allowing the water pressure to rise until the valve opens. The valve should open within +/-0.3bar (+/-4.3lb/in²) of the preset pressure. Where this is not possible conduct a manual check and test.

Release cold water to initial system design pressure.

The set pointer on the pressure gauge should be set to coincide with the indicating pointer.

6.3 Initial Lighting and Testing

CAUTION. This work must be carried out by a competent person, in accordance with the current issue of BS6798.

Make sure that all naked lights and cigarettes are out.

Identify the controls by reference to diagram 6.1.

Check that the boiler is isolated from the electrical supply.

Makes sure that the control thermostat is turned to "O" the "Off" position.

Turn the gas service cock "On", see diagram 6.1.

Test the pilot supply tube and its connections for gas soundness as follows:

Disconnect the ignition lead from the PCB, see diagram 5.6.

Remove the combustion chamber front, see diagram 6.3.

WARNING. The fan operates on mains voltage, terminals will become live.

Turn the electrical supply on and check that all remote controls are calling for heat.

Check that the pump is circulating water through the system.

To complete the test it is necessary to operate the boiler without its case, but **UNDER ALL OTHER CIRCUMSTANCES** the case must be correctly fitted and sealed.

Turn the control thermostat knob fully clockwise and the fan will work.

Note. There will be no sparks at the pilot. Take care and light the pilot with a match.

Test the pilot supply and connections for gas soundness, using a suitable leak detection fluid.

Very cold weather may delay the operating sequence.

The pilot rate is preset and must not be adjusted. The step adjustment screw must not be touched.

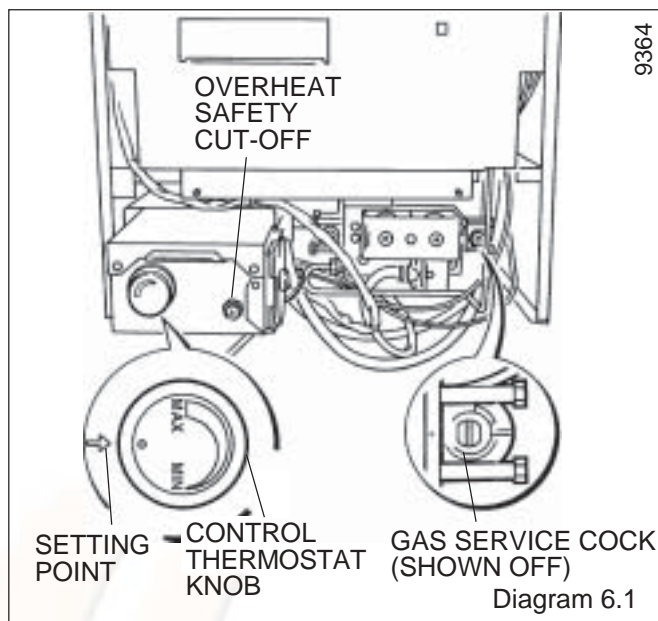

Diagram 6.1

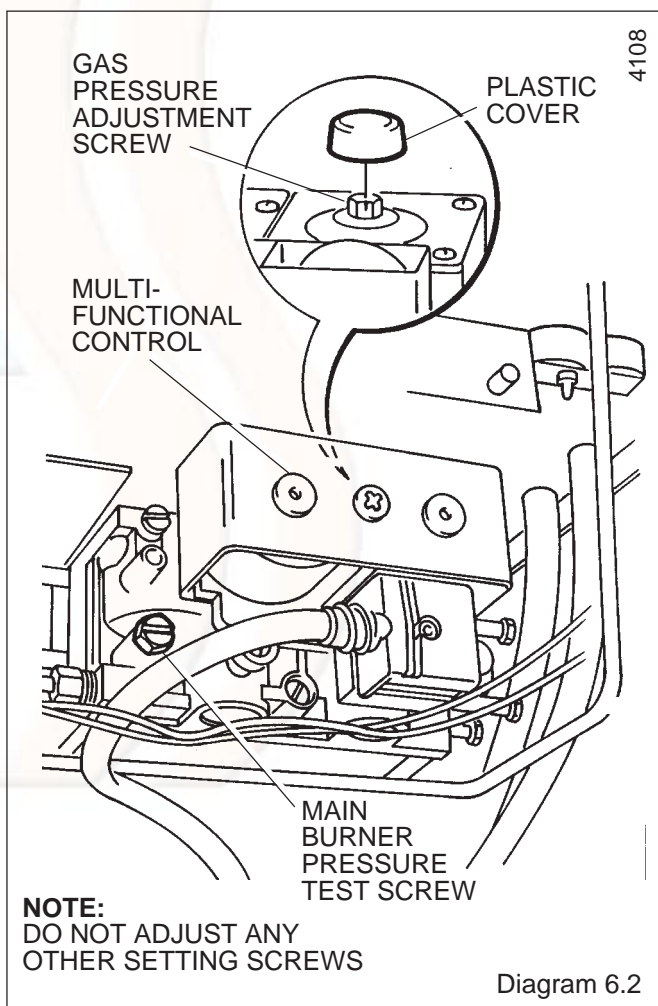

Diagram 6.2

The pilot flame length should be as shown in diagram 6.4.

Turn the control thermostat knob to "O" and isolate the boiler from the electrical supply.

6 Commissioning

Fit the combustion chamber front.

Note: Make sure it fits under lip of flue hood.

Reconnect the ignition lead to the PCB.

Stick the self adhesive arrow indicator to the data label, against the rating that the boiler is going to be set to, for future reference. The arrow is in the loose items pack.

Loosen the main burner pressure test point screw and connect a suitable pressure gauge, see diagram 6.2.

Make sure that any remote controls are calling for heat.

Switch on/connect the electrical supply to the boiler and heating system, neon 1 will light.

Note. The neon indicator lights on the printed circuit board are an aid to fault finding, for details refer to Section 9.

6.4 Testing - Electrical

Turn the boiler thermostat knob fully clockwise to the maximum setting, which is about 82°C (180°F), neon 2 will light.

The lighting sequence is automatic as follows:

The fan operates	}	neon 3 will light
The spark ignition operates		
The pilot solenoid opens		
The pilot burner lights	}	neon 4 will light
The ignition spark stops		
The main solenoid opens		

and after a short period of time the main burner will light, look through viewing window, see diagram 6.3.

Very cold weather may delay the operating sequence.

The main burner will stay alight until switched off, either by the control thermostat or a remote system control.

To make sure that the flame supervision device is working correctly the following should be done.

1. With the main burner alight, turn the gas service cock "Off", see diagram 6.1.

After a short period the main burner and pilot will go out.

2. The correct working of the flame supervision device is shown by neon 4 going out within 10 seconds and the ignition starting up.

Neons 1, 2 and 3 should stay alight.

3. If the above does not happen, refer to fault finding Section 9.1.

4. To carry on turn gas service cock "On" see diagram 6.1.

When the boiler switches "Off", both the pilot and main burner go out. The automatic lighting sequence will work again when heat is required.

If an external control switches the boiler off, the pump will run on for several minutes.

6.5 Testing - Gas

With the boiler on proceed as follows:-

Test for gas soundness around the boiler gas components using a suitable leak detection fluid, in accordance with the current issue of BS6891.

Check the main burner gas pressure at least 10 minutes after the boiler has lit, refer to Data Label, see diagram 1.3.

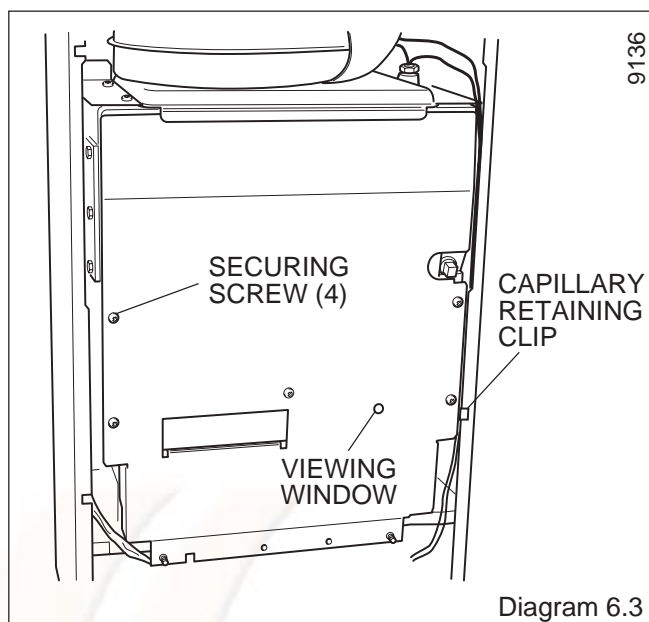

Diagram 6.3

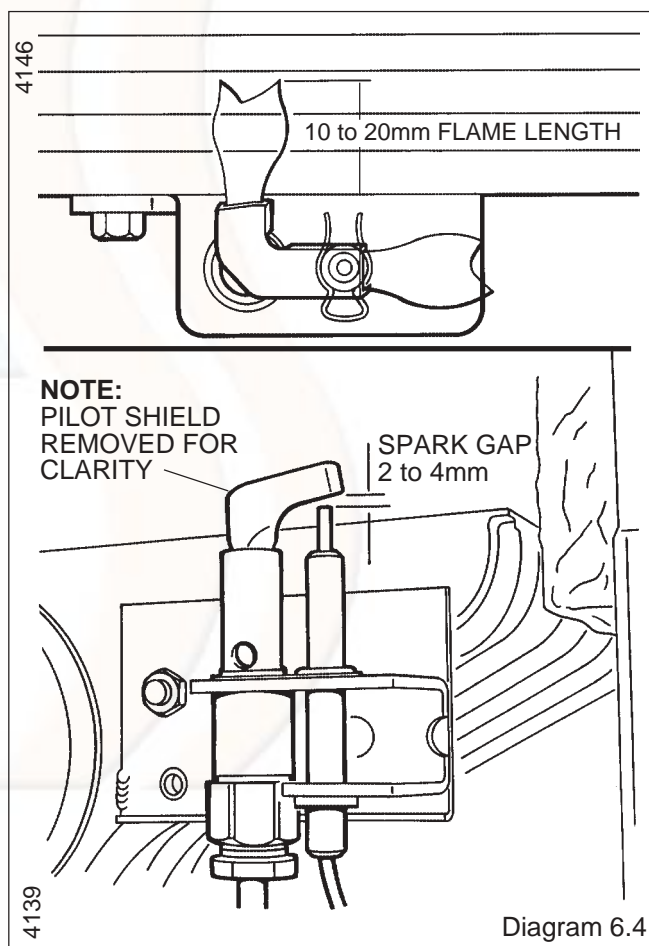

Diagram 6.4

If necessary adjust the gas pressure to obtain the required setting turning screw clockwise, to decrease pressure, see diagram 6.2.

Should any doubt exist about the gas rate, check it using the gas meter test dial and stop watch, at least 10 minutes after the burner has lit, making sure that all gas burning appliances and pilot lights are off.

6 Commissioning

Turn the control thermostat knob fully anticlockwise to "0". Remove the pressure gauge from the test point and refit screw, making sure a gas tight seal is made.

When the control thermostat is turned to the "Off" position, by hand, wait at least 30 seconds before turning "On" again.

There may be an initial smell given off from the boiler when new, this is quite normal and it will disappear after a short period of time.

Refit the electrical controls box, see diagram 5.5.

6.6 Testing - Open Vented

Allow the system to reach maximum working temperature and examine for water leaks.

There should be no undue noise in the system and no pumping over of water or entry of air at the open vent above the feed and expansion cistern.

All systems - The boiler should be turned off and the system drained off as rapidly as possible, whilst still hot.

6.7 Adjustment - Fully Pumped Open Vented and Sealed Water Systems

When commissioning the system the boiler should first be fired with the bypass fully closed on full service, that is, central heating and domestic hot water. Adjust the pump to the system design setting then balance the system. Having achieved a satisfactory condition operate the boiler with the bypass fully closed on minimum load, normally this will be central heating only with one radiator in the main living area operating. The bypass valve should be gradually opened to achieve a temperature difference no greater than 20°C between the flow and return.

UNDER NO CIRCUMSTANCES SHOULD THIS VALVE BE LEFT IN THE FULLY CLOSED POSITION.

6.8 Sealed Water Systems ONLY

Adjust the system to initial design pressure. The set pointer on the pressure gauge should be set to coincide with the indicating pointer.

6.9 Thermostatic Radiator Valves

If thermostatic radiator valves are fitted care must be taken to ensure that an adequate flow rate through the boiler when they close, refer to the current issue of BS7478 for guidance.

6.10 Protection Against Freezing

If the boiler is to be out of use for a period of time during severe weather conditions we recommend that the whole of the system, including the boiler, be drained off to avoid the risk of freezing up.

6.11 Operational Checks and Completion

Adjust the boiler thermostat and any system controls to their required settings.

Do not attempt to adjust the thermostat calibration screw.

Operate the boiler again on full service and check that the balancing is satisfactory, making adjustments as necessary.

Fit the front cover by hooking it under at the top and securing with the wing nut, washer and nut previously removed, refer to diagram 6.5.

Fit the controls cover by hooking into sliders and pushing it back as far as it will go, see diagram 6.6.

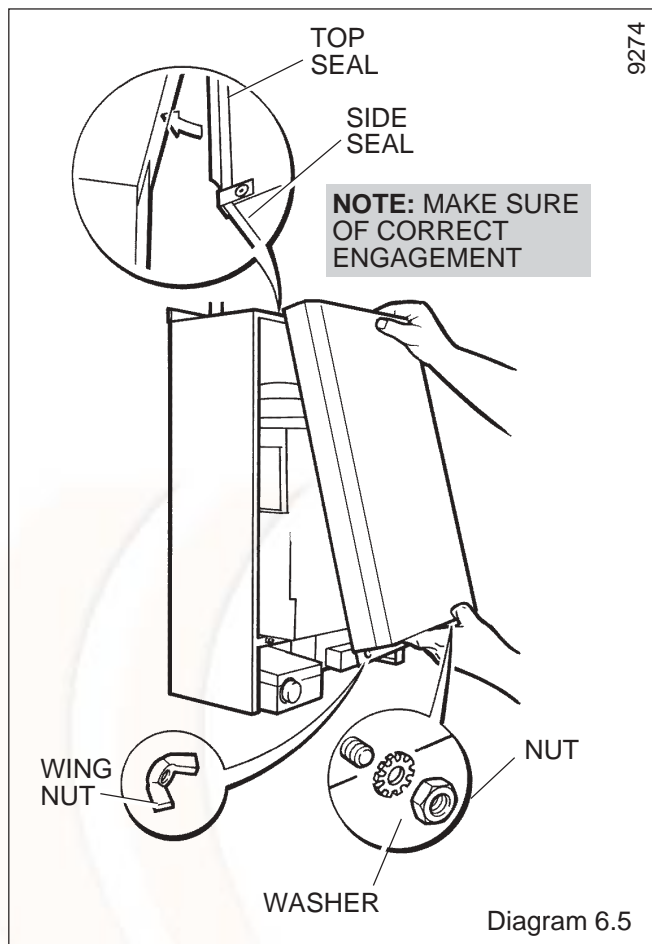

Diagram 6.5

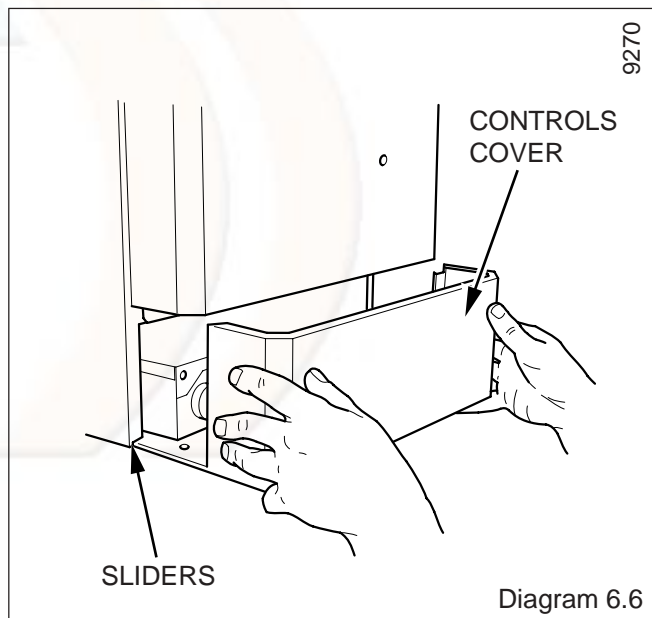

Diagram 6.6

7 Instructions to the User

Instruct and demonstrate the safe and efficient operation of the boiler, heating system and domestic hot water system.

Advise the user, that to ensure the continued efficient and safe operation of the boiler it is recommended that it is checked and serviced at regular intervals. The frequency of servicing will depend upon the particular installation and usage, but in general once a year should be enough.

Draw attention, if applicable, to the current issue of the Gas Safety (Installation and Use) Regulations, Section 35, which

imposes a duty of care on all persons who let out any property containing a gas appliance.

It is the Law that servicing is carried out by a competent person.

Advise the user of the precautions necessary to prevent damage to the system and building in the event of the heating system being out of use during frost and freezing conditions.

Reminder - Leave these instructions and the "Benchmark" logbook with the user.

8 Servicing

REMEMBER, When replacing a part on this appliance, use only spare parts that you can be assured conform to the safety and performance specification that we require. Do not use reconditioned or copy parts that have not been clearly authorised by Hepworth Heating Ltd.

Notes. To ensure the continued efficient and safe operation of the boiler it is recommended that it is checked and serviced as necessary at regular intervals. The frequency of servicing will depend upon the particular installation conditions and usage, but in general once a year should be enough.

It is the Law that any servicing is carried out by a competent person.

Before servicing turn off the gas and isolate the electrical supply to the boiler.

After completing a service always test for gas soundness and carryout functional check on controls.

Unless stated otherwise all parts are replaced in the reverse order to removal.

8.1 Access

Remove the controls cover by pulling forward, see diagram 6.6.

Remove the front cover by undoing the wing nut, nut and washer, lift the front cover off, see diagram 6.6.

Note. As an aid to Servicing the air pressure switch tube connection can be used to obtain a products of combustion reading.

Remove the RED tube from the connection on the air pressure switch and insert the analyser probe into the tube.

Switch on the electrical supply to operate the fan and turn on the gas supply.

On completion of the test switch off the electrical supply and the gas supply and reconnect the red tube to the air pressure switch.

8.2 Cleaning Heat Exchanger Flueways

Disconnect the air pressure tubes, see diagram 8.1

Remove the blue and red electrical connections from the fan, then loosen jubilee clip to release flue duct extension assembly, see diagram 8.1.

Remove the front right hand flue hood securing screw and slacken off the front left hand one, see diagram 8.3.

Holding the flue duct extension with the right hand and the fan with the left, draw the fan and flue hood assembly forward allowing the flue duct extension to rotate slightly in the top turret flue ducting to allow the fan to be withdrawn from the flue duct extension, see diagram 8.1.

Remove the combustion chamber front.

Remove the burner as Section 8.3.

Place a sheet of paper in the base of the combustion chamber.

Remove the baffles, see diagram 8.2.

Clean the heat exchanger flueways with a suitable stiff brush.

Remove the paper together with any debris.

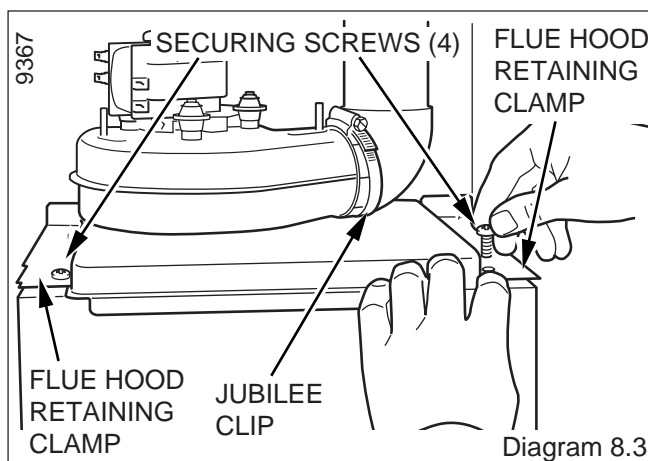
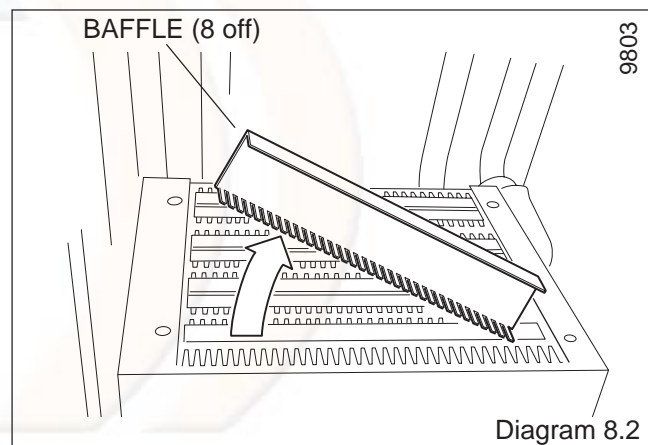
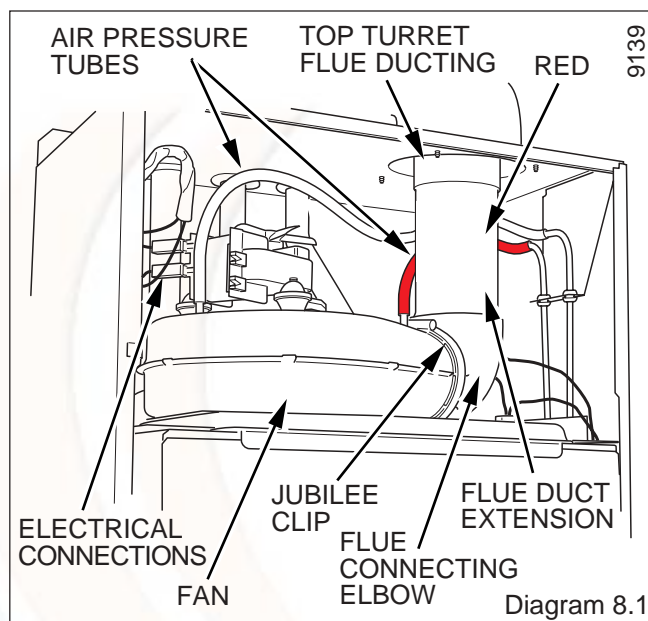

8 Servicing

8.3 Main Burner

Disconnect the pilot pipe union connector and pilot burner, securing nut and shakeproof washer together with the pilot shield. Remove the pilot burner assembly taking care not to damage the electrode and lead assembly, see diagram 8.4.

Remove the securing screw from the burner support bracket, see diagram 8.5.

Remove the main burner from the main injector at the rear. Raise the burner up and forwards, easing the pilot pipe down, to clear, take care not to damage the combustion chamber insulation or the pilot pipe.

Use a vacuum cleaner or suitable stiff brush to clean the burner thoroughly, making sure that all the burner ports are clear and unobstructed.

Continue cleaning heat exchanger as Section 8.2.

Note. On refitting and after cleaning the heat exchanger make sure the burner is fitted correctly, that is, located on the main injector and horizontal.

8.4 Main Injector

With the main burner removed the main injector can be inspected and cleaned as necessary, see diagram 8.6.

If removing for cleaning do not use a wire or sharp instrument on the hole.

Use a little suitable sealant on the external thread when refitting making sure a gas tight seal is made.

8.5 Pilot Burner/Electrode and Pilot Injector

Clean the pilot burner and electrode.

To remove the electrode release the spring clip, see diagram 8.7.

When removing and replacing the pilot injector from the pilot burner take care not to damage the electrode, see diagram 8.7, clean the injector by blowing through it.

Check that the spark gap is as shown in diagram 6.4.

8.6 Operational Checks

After completing a service and before fitting the case, check condition of the case seal and renew if necessary.

Examine flue hood and terminal to make sure they are clean and clear of obstructions.

Light the boiler and carryout the functional checks as described in Section 6.

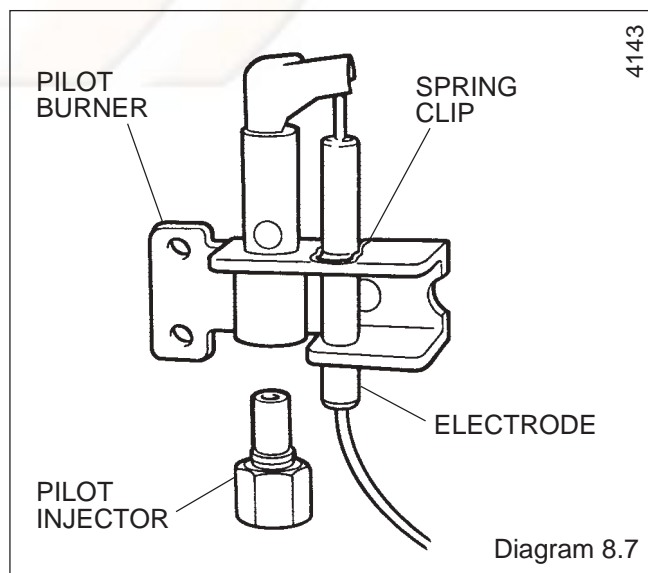
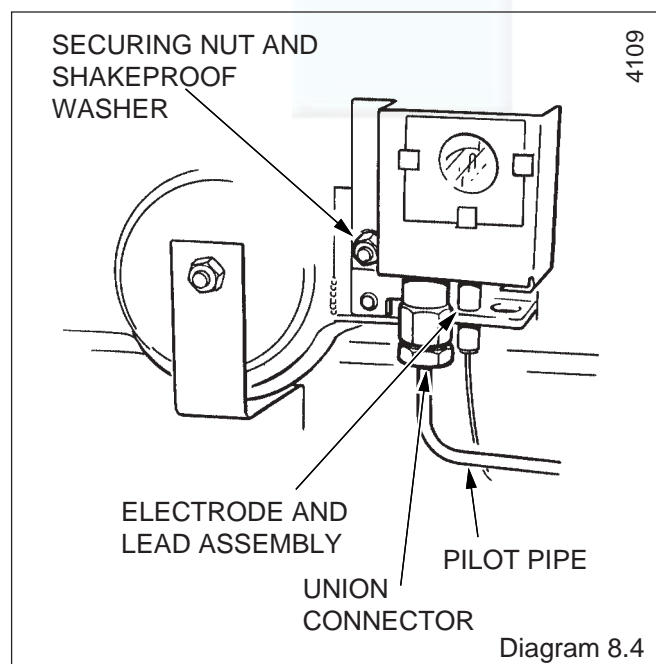
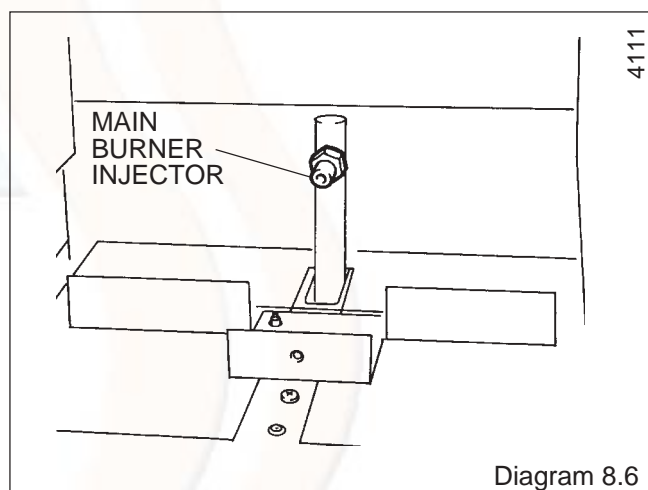
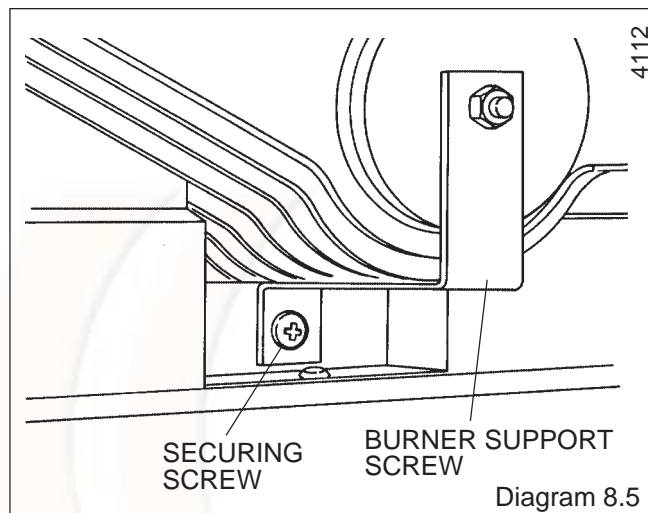

9 Fault Finding

9.1 Electrical

Important. On completion of the Service/Fault Finding task which has required the breaking and remaking of the electrical connections the earth continuity, polarity, short circuit and resistance to earth checks must be repeated using a suitable multimeter.

Refer to neon indicators "An Aid to Fault Finding" diagram 9.1, Boiler Fault Finding diagram 9.2, Pump Overrun Fault Finding diagram 9.3, the Functional Flow diagram 9.4, and the Pictorial Wiring diagram 9.5.

9.2 Electrical Supply Failure

Failure of the electrical supply will cause the burner to go out. Operation will normally resume on restoration of the electrical supply. If the burner does not relight after an electrical supply failure the overheat device may need resetting.

Remove the control cover, see diagram 6.6 and press the reset button on the front of the control box, see diagram 6.1.

If the cutoff operates at any other time press the reset button and the burner should relight. If the fault persists refer to fault finding chart.

Note: The pump may run for several minutes when power is first applied, regardless of call for heat.

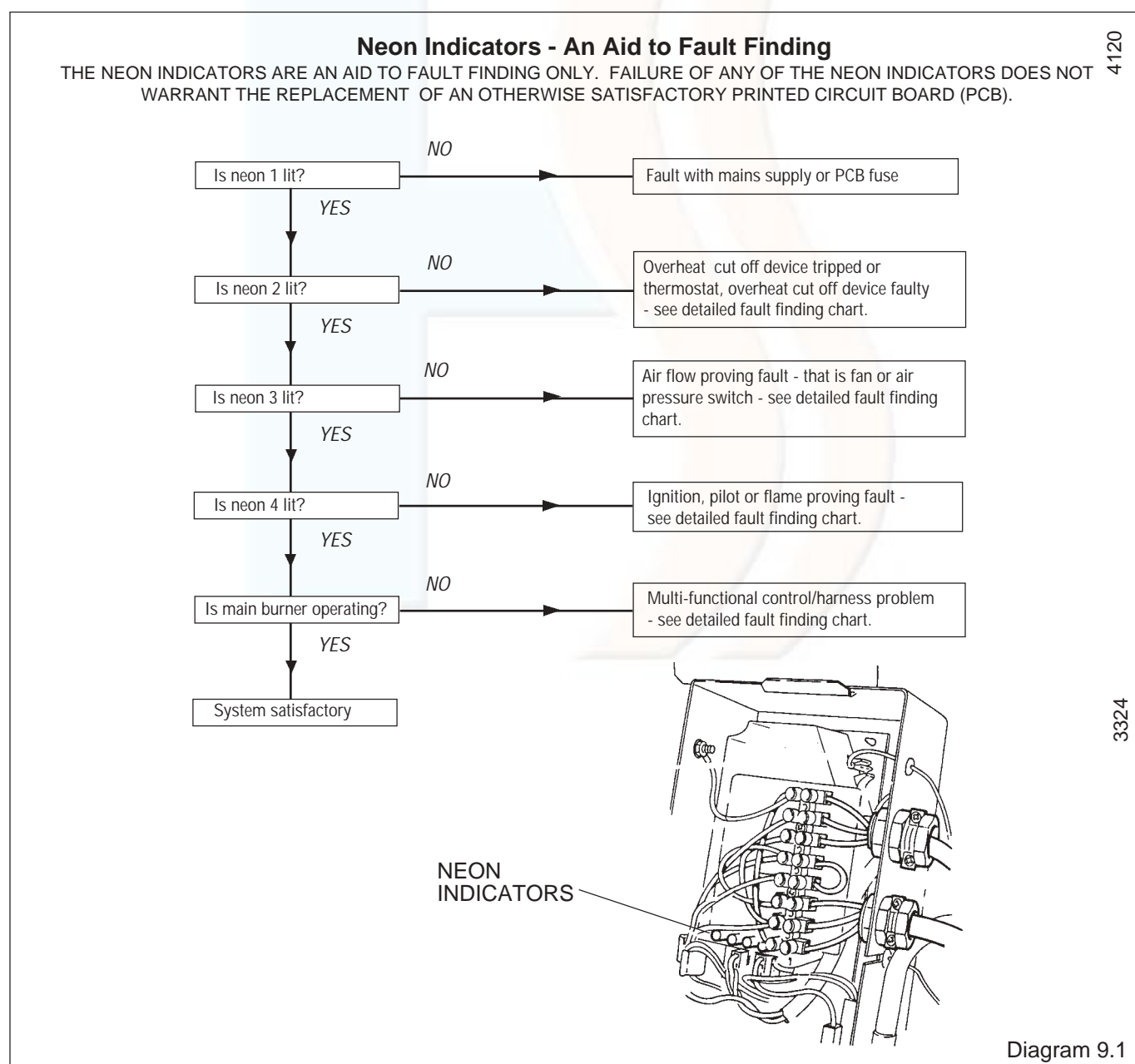

9 Fault Finding

Before detailed checking of electrical components ensure that remote controls are calling for heat. Check the gas supply is free of obstructions and purged of air. Check the overheat cutoff has not operated. For fully pumped systems only. Isolate the electrical supply and physically check ALL cables, connections and the printed circuit board fuse. Check the air tubes to the air pressure switch. Switch on the electrical supply and check for correct polarity. Turn the boiler thermostat to its maximum setting. Also check fuses.

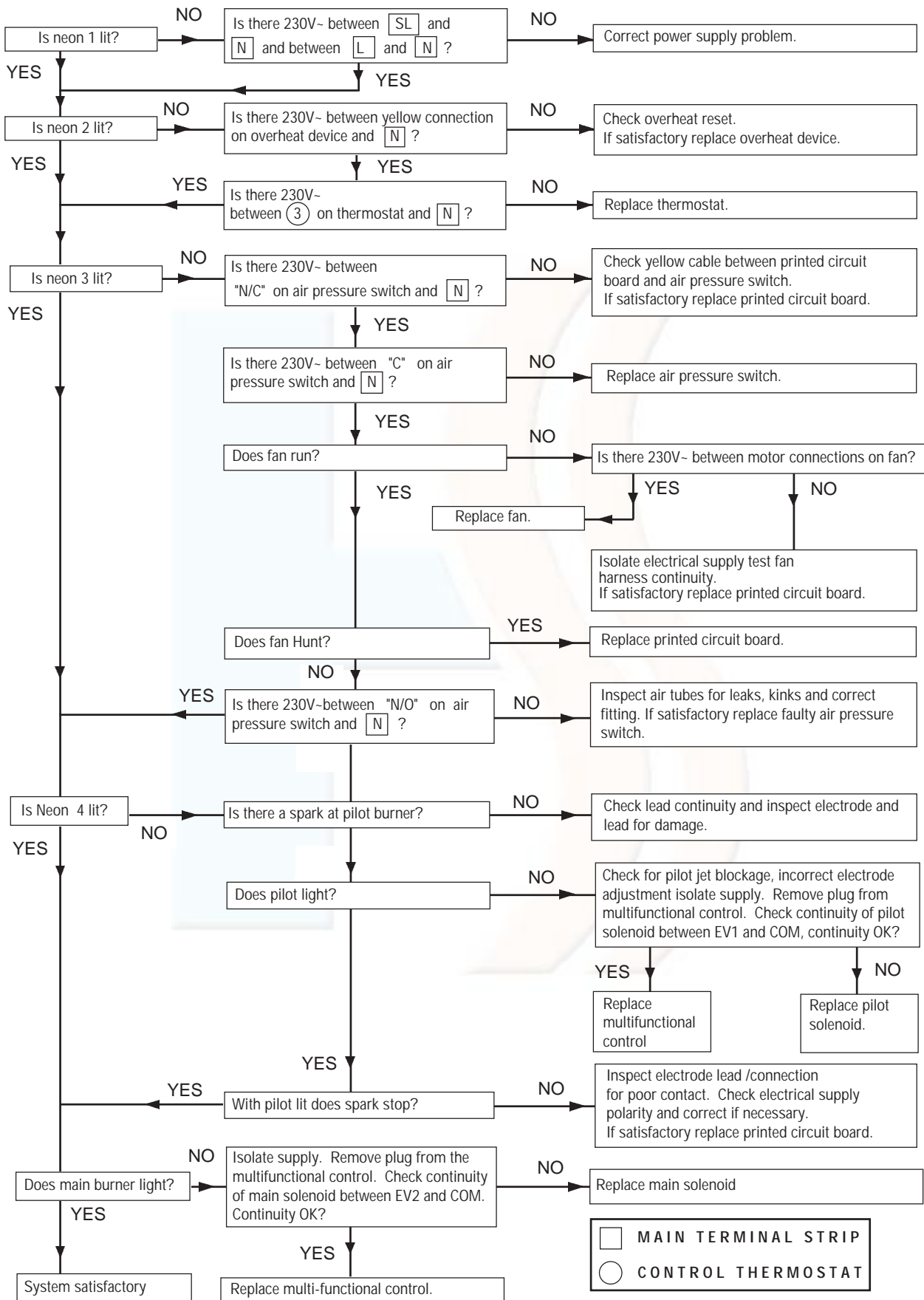
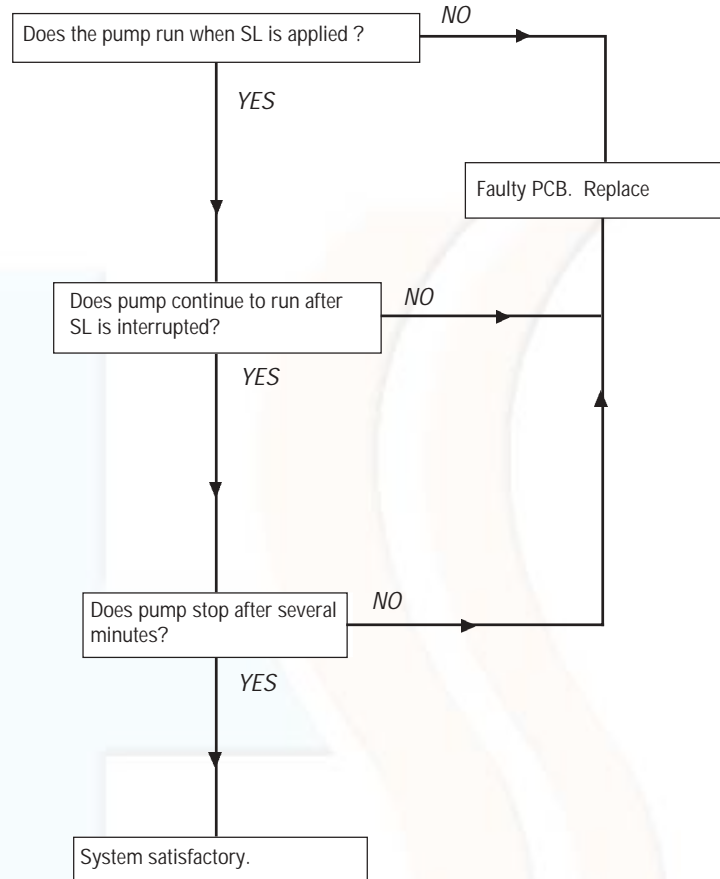

Diagram 9.2

9 Fault Finding

Pump Overrun Operation For Fully Pumped System Only

The PCB has a timed pump overrun facility.
 The pump should run for several minutes after remote controls have stopped calling for heat.
 Before using the fault finding chart ensure all wiring is correct and in good condition, the pump is not faulty and check the PCB fuse F2



**FOR FULLY PUMPED OPEN VENTED
 OR SEALED WATER SYSTEMS ONLY**

Diagram 9.3

9 Fault Finding

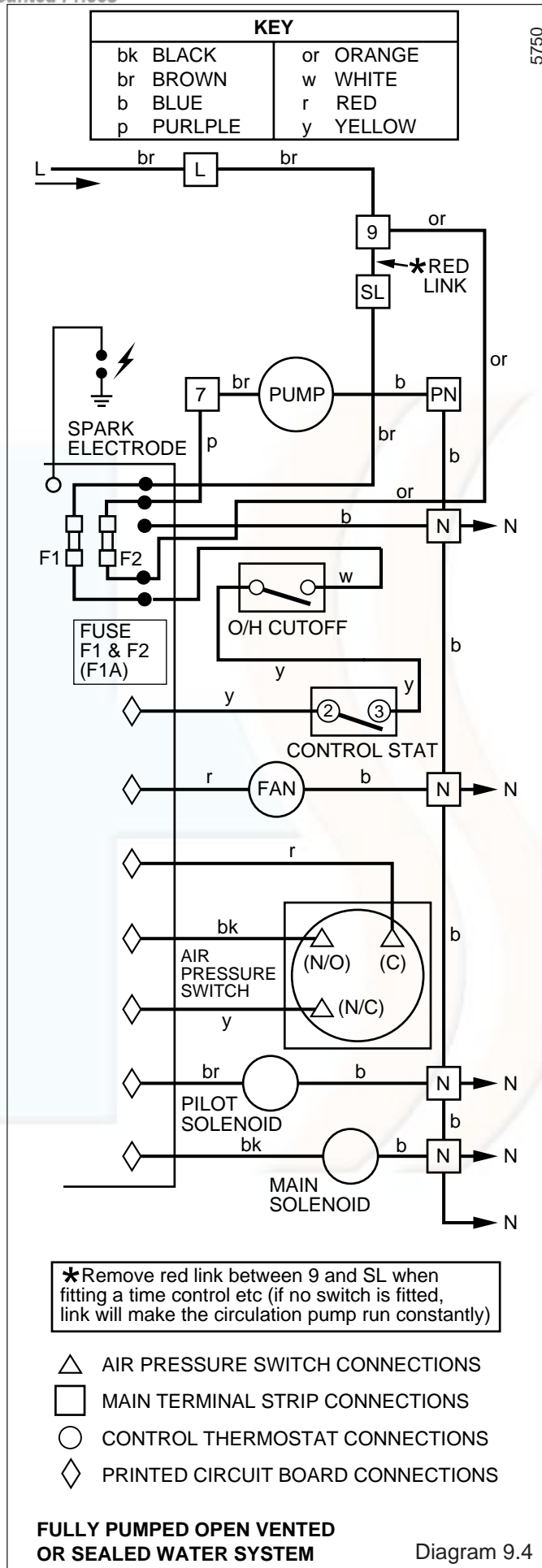

9 Fault Finding

5751

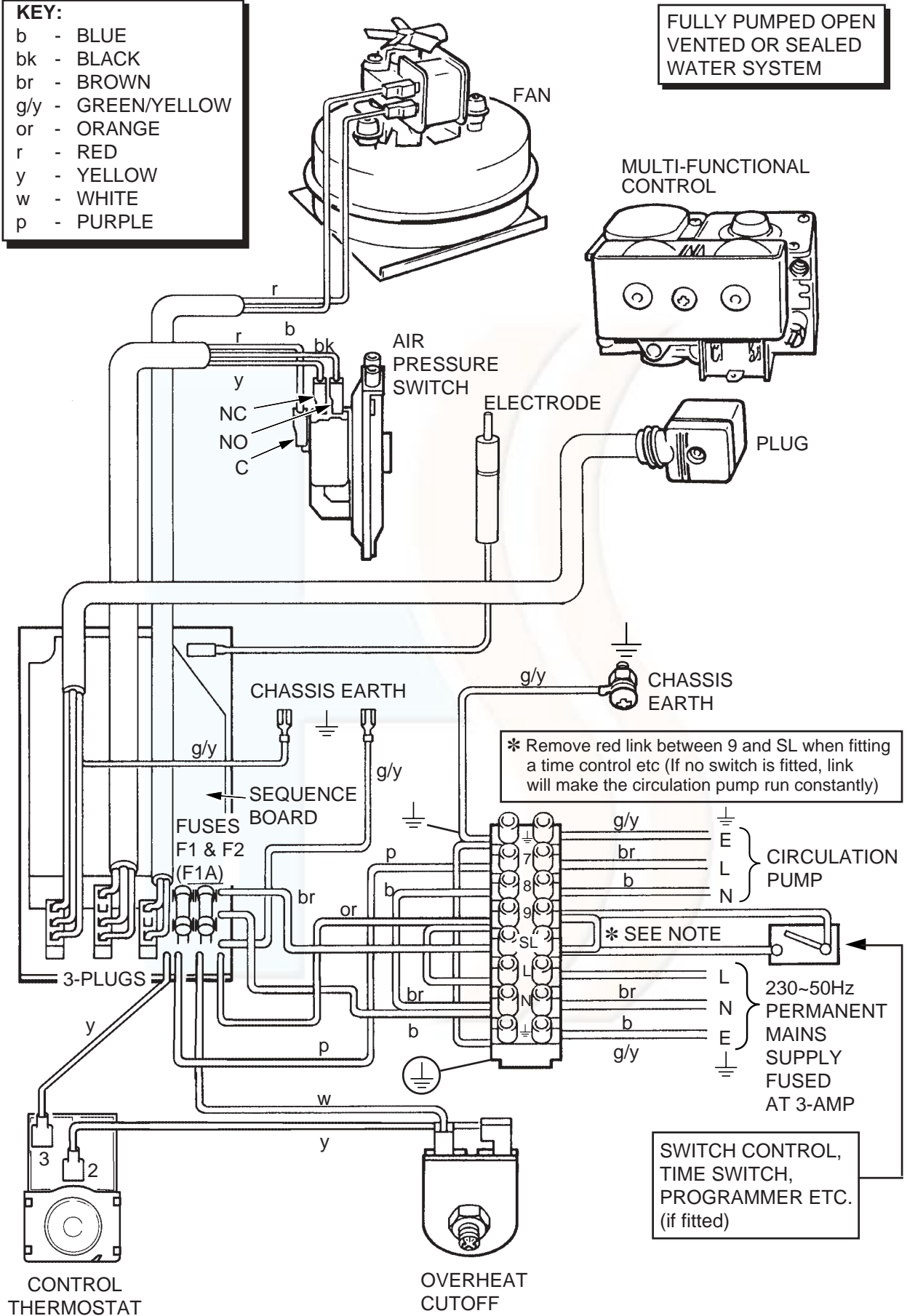

Diagram 9.5

10 Replacement of Parts

10 Replacement of Parts

Note. Replacement of parts must only be carried out by a competent person.

Before replacing any parts isolate the boiler from the electrical supply and turn the gas supply off at the gas service cock, indicator slot should be vertical.

Unless state otherwise, all parts are replaced in the reverse order to removal.

After replacing any parts always test for gas soundness and if necessary carryout functional check of controls.

10.1 Access

Gain access as Section 8.1.

10.2 Control Thermostat diagram 10.1 and 10.2

Remove and support the electrical control box, refer to Section 5.6.

Remove the control knob. Remove the electrical connections from the thermostat body.

Release the thermostat body by unscrewing the two screws and shakeproof washers in the front of the control box.

Remove the split pin and withdraw the thermostat phial from its pocket. Release the capillary from the base and plastic retaining clip then remove it from the split grommet. Release the capillary from its clips. Remove the thermostat complete from the boiler.

Reassembly note. When fitting the thermostat, make sure that the thermostat phial is covered with heat sink compound then fully inserted into the phial pocket and that the capillary is within the gland seal, see diagram 10.2. Remake the electrical connections. There must be no kinks or sharp bends in the capillary.

10.3 Over Heat Cutoff Device - diagram 10.1, 10.2 and 10.2A

Remove and support the electrical control box, refer to Section 5.6.

Remove the overheat cutoff electrical connections.

Disconnect the air pressure switch plug from the PCB.

Remove the locking nut from the overheat cutoff.

Release the capillary from the retaining clips then remove it from the split grommet.

Loosen the retaining bracket and remove the phial.

When refitting use the heat sink compound supplied.

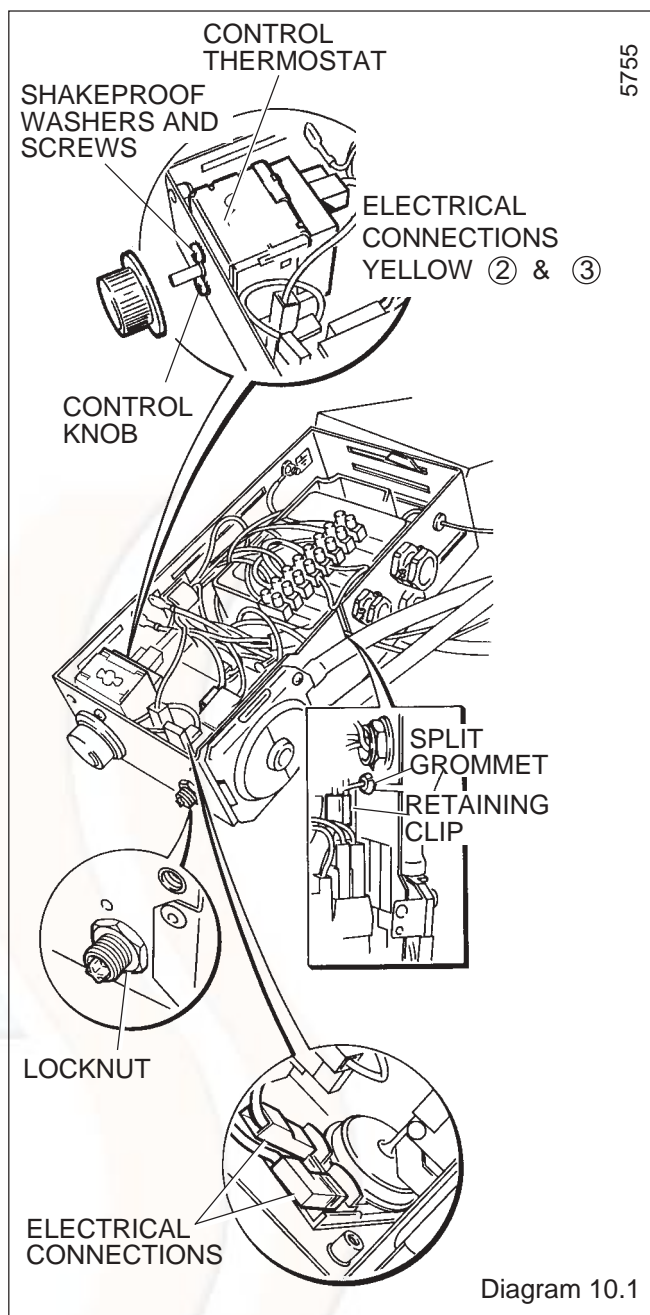

10 Replacement of Parts

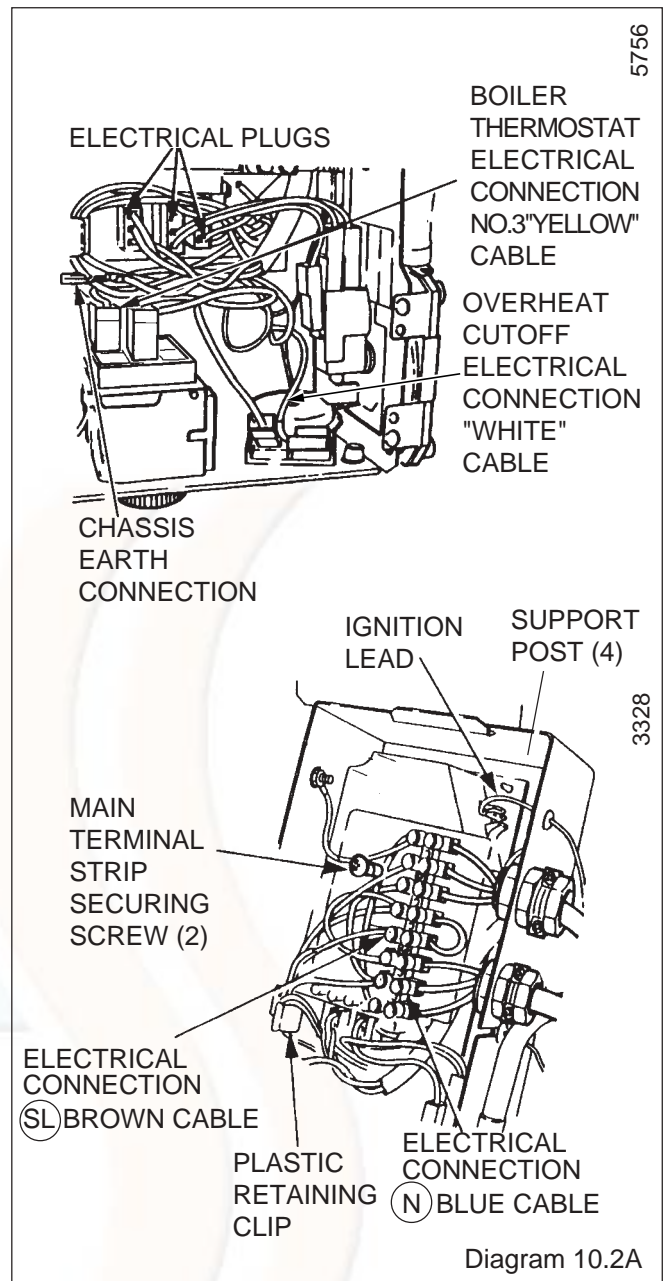
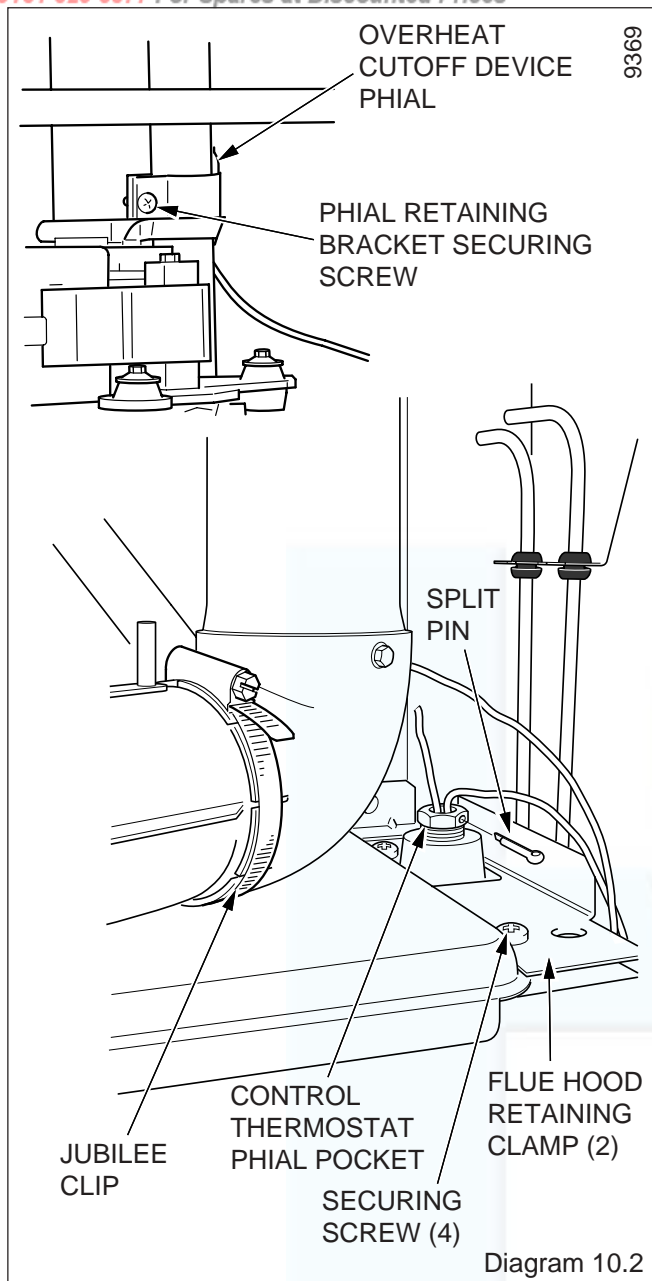

10.4 Control Board (PCB) - diagram 102A

Release the control box, refer to Section 5.6.

Disconnect the three electrical plugs and ignition lead.

Release the cables from the plastic retaining clip, then disconnect the cables from the PCB to the main terminal strip, control thermostat and earth connection.

Release the main terminal strip and plastic label.

Carefully pull the board away from its supports.

When refitting refer to wiring diagram 9.5.

10.5 Pilot Burner and Pilot Injector

Proceed as Section 8.3 and 8.5.

10.6 Electrode

Proceed as Section 8.3 and 8.5.

Gain access as Section 5.6 to remove lead from control box.

10 Replacement of Parts

10.7 Multifunctional Control - diagram 10.3

Disconnect the pilot supply by unscrewing the tubing nut at the multifunctional control, take care as there is a restrictor on the pilot pipe.

Disconnect the electrical plug.

Support the multifunctional control, remove the four extended screws from the flanged connections at the left and right hand side.

Remove and discard the original "O" rings from the flanged connections and fit the new "O" ring supplied, into recess, before fitting the replacement multifunctional control.

After assembly test for gas soundness and purge in accordance with the current issue of BS6891.

10.8 Solenoid - diagram 10.3

Remove the electrical plug from the multifunctional control. Remove the securing screw and then the solenoid Assembly.

10.9 Main Burner

Remove the main burner as Section 8.3.

10.10 Main Injector

Remove the main burner as Section 8.3.

Remove the main injector as Section 8.4.

10.11 Insulation - 10.4

Combustion Chamber Front

Remove the retaining screw then the insulation.

Sides

Slide the insulation out.

Rear

With the side insulation removed the rear insulation can be removed and replaced.

10.12 Viewing Window - diagram 10.5

Remove the old self adhesive aluminium foil gasket and the old mica window. Replace with a new mica window. Peel off the backing paper and secure with new self adhesive aluminium foil gasket, see diagram 10.5. Ensure no air bubbles are trapped underneath the foil.

Important

Make sure that the mica window fully covers the opening and that the hole in the aluminium foil gasket is centred over opening.

10.13 Air Pressure Switch - diagram 10.6

Release the control box as Section 5.6.

Remove the air pressure tubes and electrical connections from the PCB, release the screws and remove the switch.

When fitting the replacement make sure that the plastic tubes and electrical connections are made as shown in diagram 9.5 and 10.6.

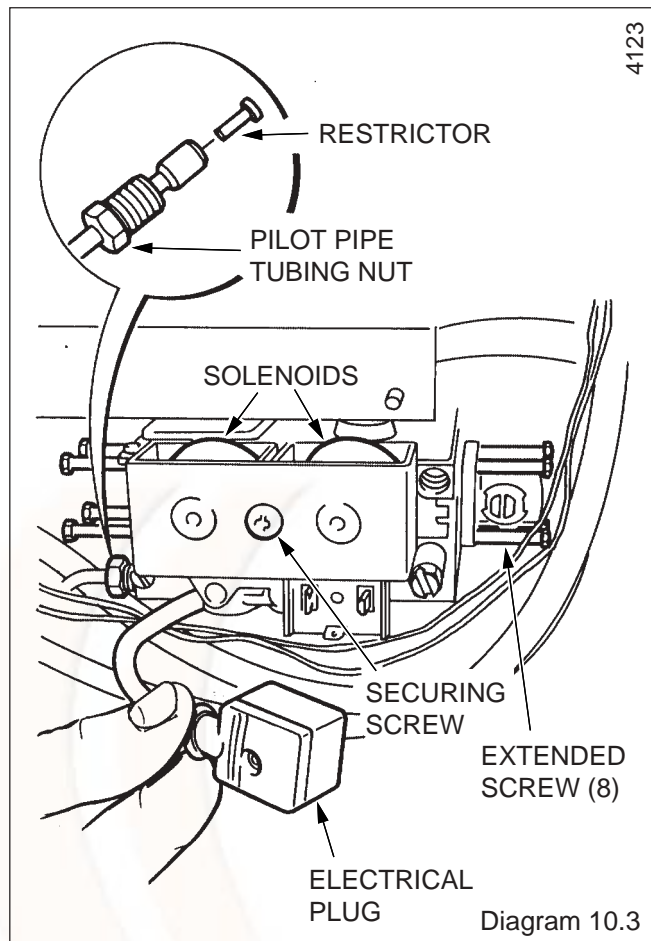

10.14 Fan - diagram 8.1

Remove the electrical connections and disconnect the air. Disconnect the air pressure tubes, see diagram 8.1

Remove the blue and red electrical connections from the fan, then loosen jubilee clip to release flue duct extension assembly, see diagram 8.1.

Remove the front right hand flue hood securing screw and slacken off the front left hand one, see diagram 8.3.

Holding the flue duct extension with the right hand and the fan with the left, draw the fan and flue hood assembly forward allowing the flue duct extension to rotate slightly in the top turret flue ducting to allow the fan to be withdrawn from the flue duct extension, see diagram 8.1.

Remove the fan from the flue hood by unscrewing the three retaining screws.

Make sure that the earth connection is remade on to the new fan assembly.

The polarity of the other connections is not important.

10 Replacement of Parts

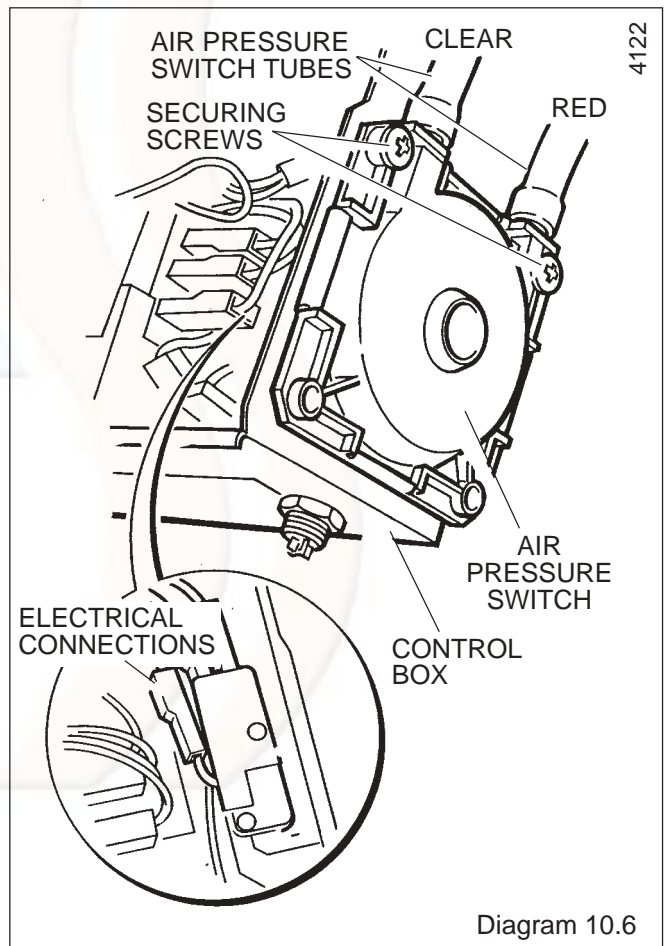
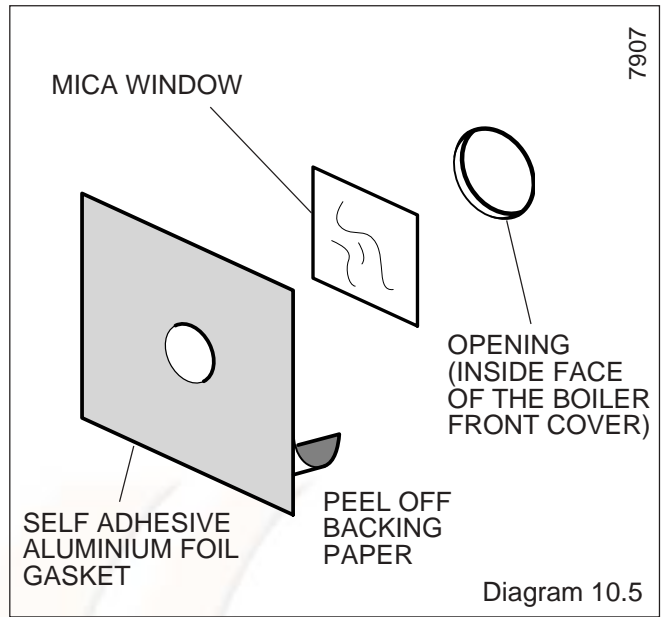
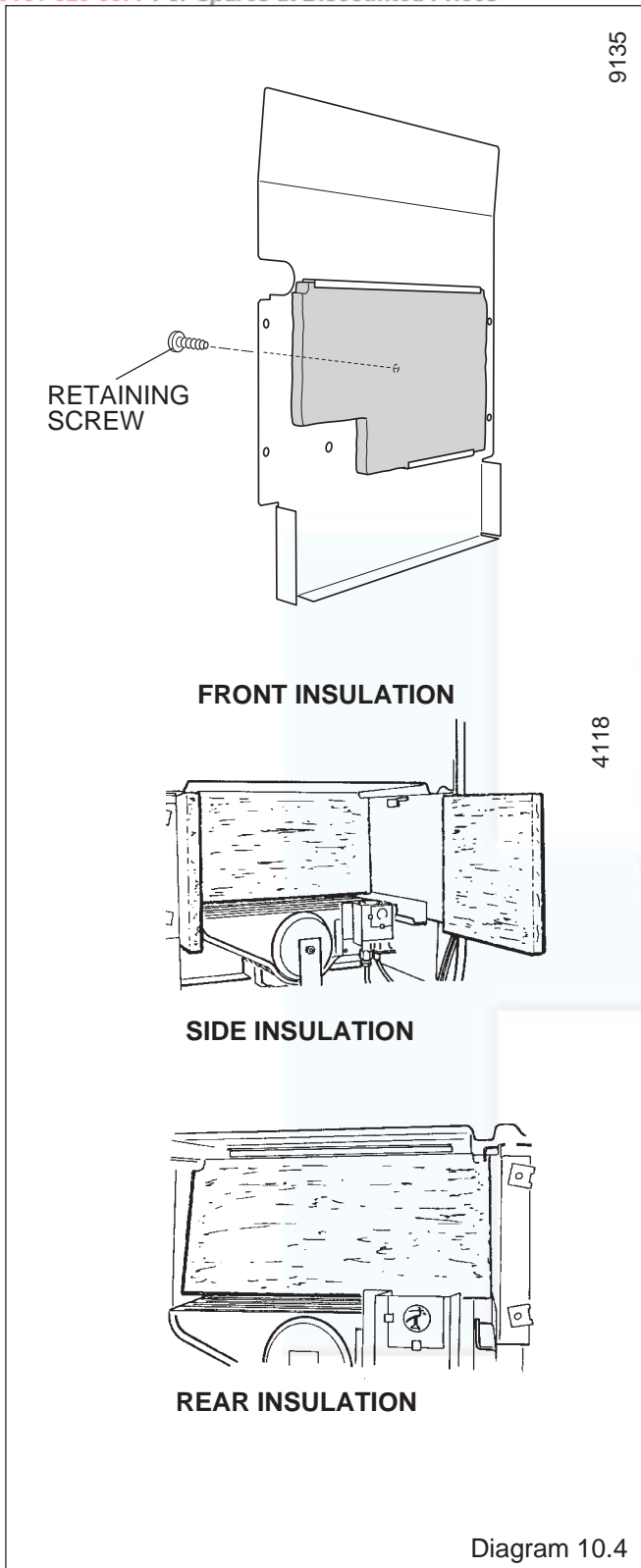

11 Spare Parts

11.1 Part Identification

The key number on the diagram and the list will help to identify the part.

11.2 Ordering

When ordering any spare parts please quote the number and description from the list together with the model name and serial number.

If ordering from British Gas also quote the GC number of the appliance and part.

Key No.	Part No.	Description	GC Part No.
1	800442	Multifunctional control	278 021
2	208040	"O" ring	334 592
3	205710	Injector	278 024
4	203432	Pilot burner	278 023
5	801236	Mica window and gasket	
6	800421	Fan assembly	278 008
7	202626	Spark electrode and lead	313 998
8	K3580	Clip	390 983
9	800850	Thermostat	
10	202201	Air pressure switch	313 992
11	800400	Control knob	313 609
13	202015	Fuse	334 750
14	900847	Control board PCB	
15	800479	Overheat cutoff device	278 188

11 Spare Parts

9216

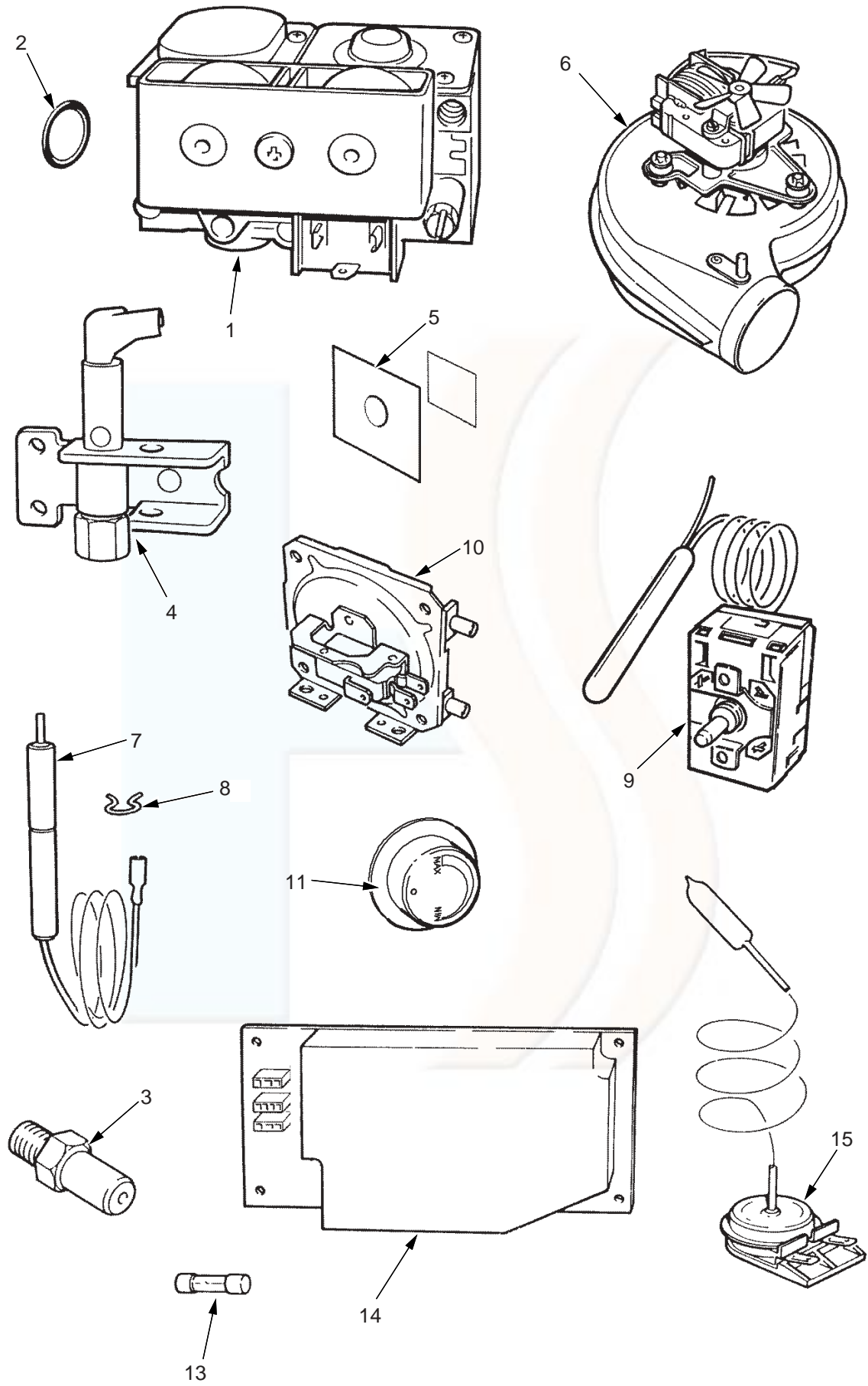

Diagram 11.1

Because of our constant endeavour for improvement, details may vary slightly from those shown in these instructions.