

CONTENTS

1	DESCRIPTION OF THE BOILER	pag. 46
2	INSTALLATION	pag. 47
3	CHARACTERISTICS	pag. 51
4	USE AND MAINTENANCE	pag. 53

IMPORTANT

When carrying out commissioning of the boiler, you are highly recommended to perform the following checks:

- Make sure that there are no liquids or inflammable materials in the immediate vicinity of the boiler.
- Make sure that the electrical connections have been made correctly and that the earth wire is connected to a good earthing system.
- Open the gas tap and check the soundness of the connections, including that of the burner.
- Make sure that the boiler is set for operation for the type of gas supplied.
- Check that the flue pipe for the outlet of the products of the combustion is unobstructed.
- Make sure that any shutoff valves are open.
- Make sure that the system is charged with water and is thoroughly vented.
- Purge the system, bleeding off the air present in the gas pipe by operating the pressure relief valve on the gas valve inlet.

FONDERIE SIME S.p.A of Via Garbo 7 -Legnago (VR)-Italy declares that its hot water boilers, which bear the EC mark under Gas Directive 90/396/EEC and are fitted with a safety thermostat calibrated to a maximum of 110 °C, are excluded from application of Directive PED 97/23/EEC in that they satisfy the requirements of article 1 paragraph 3.6 of this Directive.

1 DESCRIPTION OF THE BOILER

- IT
- ES
- PT
- GB
- FR
- BE
- GR
- RO
- RUS

1.1 INTRODUCTION

The "RMG Mk.II" are hot water generators designed for medium-sized heating plants. Are designed and built in accordance with

the european directives 90/396/CEE, 89/336/CEE, 73/23/CEE, 92/42/CEE and with the european specification EN 656. These appliances can be fired by natural

gas (methane) and butane gas (G30) or propane gas (G31). The instructions given in this manual are provided to ensure proper installation and perfect operation of the appliance.

1.2 DIMENSIONS

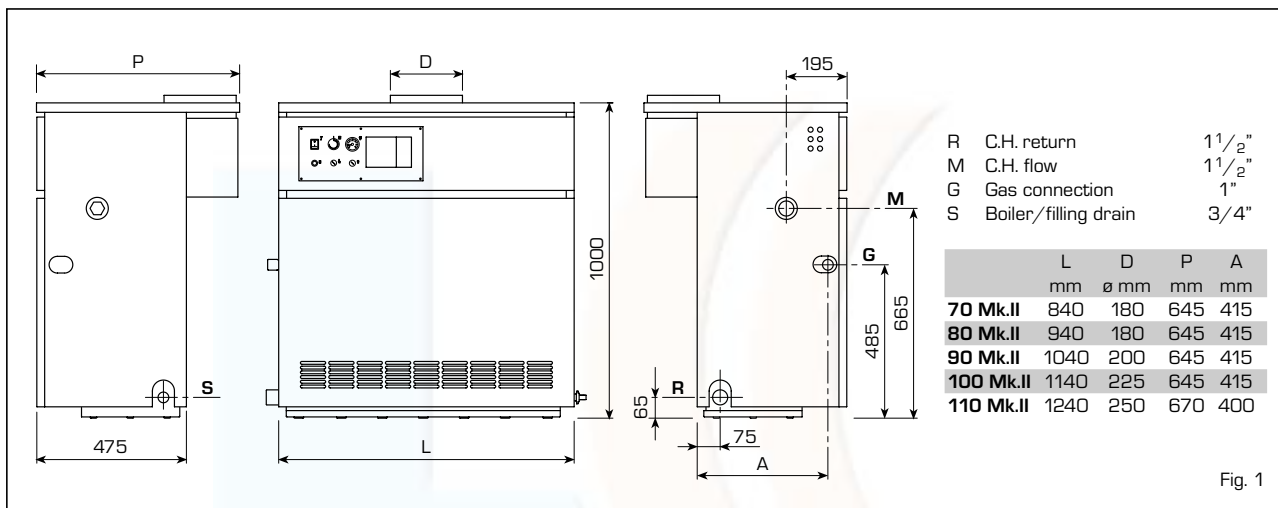

1.3 TECHNICAL FEATURES

		70 Mk.II	80 Mk.II	90 Mk.II	100 Mk.II	110 Mk.II
Heat output	kW	49.1-70.1	56.0-78.7	63.0-90.0	69.9-98.6	74.7-107.9
Heat input	kW	54.5-77.9	62.2-87.4	70.0-100.0	77.7-109.5	85.5-120.5
Sections	n°	8	9	10	11	12
Power consumption	W	16	16	16	16	69
Maximum water head	bar	4	4	4	4	4
Test pressure	bar	6	6	6	6	6
Water content	l	25	28	31	34	37
Category		II2H3+	II2H3+	II2H3+	II2H3+	II2H3+
Type		B11BS	B11BS	B11BS	B11BS	B11
Smokes temperature	°C	158	160	160	144	140
Smokes flow	kg/h	170	180	230	287	330
Maximum temperature	°C	95	95	95	95	95
C.H. setting range	°C	40÷85	40÷85	40÷85	40÷85	40÷85
Main burner nozzles						
Quantity	n°	7	8	9	10	11
Natural gas	ø mm	2.95	2.95	2.95	2.95	2.95
G30 - G31	ø mm	1.70	1.70	1.70	1.70	1.70
Gas consumption *						
Natural gas	m ³ st/h	8.2	9.2	10.6	11.6	12.7
Butane (G30)	kg/h	6.0	6.8	7.7	8.5	9.3
Propane (G31)	kg/h	5.9	6.7	7.6	8.3	9.1
Burner gas pressure						
Natural gas	mbar	4.5 - 9.3	4.6 - 9.1	4.7 - 9.3	4.7 - 9.3	4.6 - 9.3
Butane (G30)	mbar	12.2 - 25.2	12.3 - 25.4	12.0 - 25.1	12.5 - 25.1	12.6 - 25.6
Propane (G31)	mbar	16.4 - 32.6	16.1 - 30.2	15.6 - 30.0	16.6 - 32.7	16.6 - 34.3
Gas supply pressure						
Natural gas	mbar	20	20	20	20	20
Butane (G30)	mbar	30	30	30	30	30
Propane (G31)	mbar	37	37	37	37	37
Weight	kg	238	266	294	322	350

* The gas consumptions refer to the calorific value at standard conditions at 15°C - 1013 mbar.

1.4 MAIN COMPONENTS

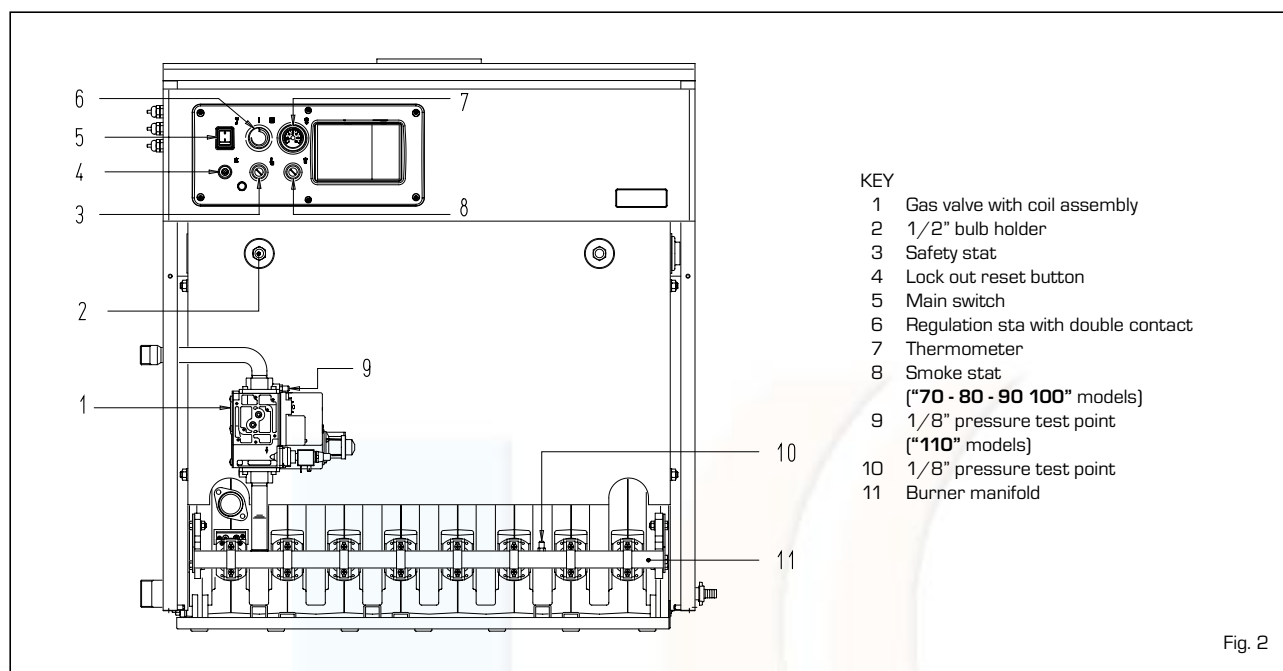

- KEY
- 1 Gas valve with coil assembly
 - 2 1/2" bulb holder
 - 3 Safety stat
 - 4 Lock out reset button
 - 5 Main switch
 - 6 Regulation sta with double contact
 - 7 Thermometer
 - 8 Smoke stat
 - 9 1/8" pressure test point ("70 - 80 - 90 100" models)
 - 10 1/8" pressure test point ("110" models)
 - 11 Burner manifold

2 INSTALLATION

The boiler must be installed in a fixed location and only by specialized and qualified firms in compliance with all instructions contained in this manual.

Furthermore, the installation must be in accordance with current standards and regulations.

2.1 BOILER ROOM

The "RMG Mk.II" boilers with a rating of more than 35 kW must be equipped with a technical room whose dimensions and requirements correspond to the current safety standards.

The minimum height of the boiler room must comply with what is indicated in fig. 3 in relation to the overall thermal capacity.

The minimum distance between the walls of the room and the external points of the boiler (right, left side, rear) must not be less than 0.60 m.

It is possible to place a number of appara-

tus next to each other, on condition that all the safety and control devices can be easily reached. In addition, to circulate air in the room, air vents must be made on the outside walls for which the surface area must never be less than 3,000 cm² and 5,000 cm² for gas with a density greater than 0.8.

2.1.1 Handling

Once the boiler is in its place of installation and the packaging has been removed, proceed as follows if it must be moved (fig. 3/a):

- remove the casing cover;
- attach the lifting brackets (located on the rear of the boiler) and fasten it in place

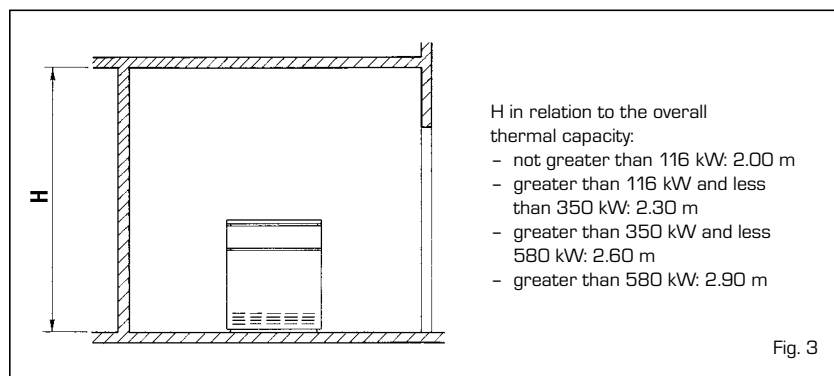

- IT
- ES
- PT
- GB**
- FR
- BE
- GR
- RO
- RUS

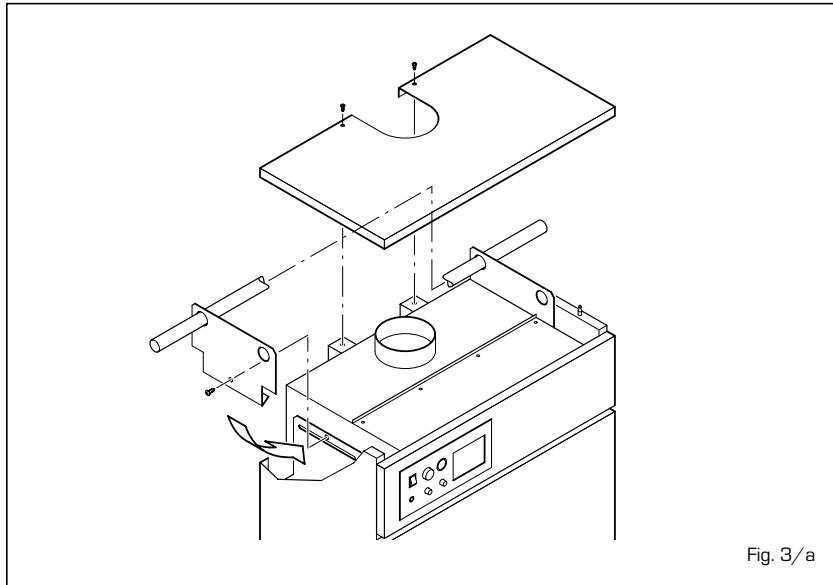

Fig. 3/a

with the screws provided;
 - insert two 3/4" pipes in the holes in the brackets, lift the boiler carefully and place into position.

2.2 CONNECTING UP SYSTEM

Before proceeding to connect up the boiler, you are recommended to make the water circulating in the piping in order to eliminate any foreign bodies that might be detrimental to the operating efficiency of the appliance.

The unit must be connected up with rigid pipe fittings which will not subject it to stress of any kind.

The connections should be easy to disconnect using pipe unions with orientable connections. You are recommended to install suitable shutoff valves on the system flow and return pipes.

In order to achieve a good water distribution inside the cast-iron body, the system flow and return pipes should be connected to the same side of the boiler.

The boiler comes supplied standard with the attachments on the right-hand side, with the possibility of them being transferred to the left-hand side.

In that case, move the water distributor, located on the return header, and the thermostat bulbs located in the sheathe, to the same side.

The thermal jump between the system flow and return pipes should not exceed 20°C. For this purpose, it is advisable to install a mixer valve with corresponding anti-condensation pump.

CAUTION: The system circulation pump or pumps must go into action at the time of boiler ignition.

For this purpose, you are recommended to use an automatic system of precedence.

The gas connection must be made using seamless steel pipe (Mannesmann type), galvanized and with threaded joints provided with gaskets, excluding three-piece connections, except for initial and end connections. Where the piping has to pass through walls, a suitable insulating sleeve must be provided.

When sizing gas piping, from the meter to the boiler, take into account both the volume flow rates (consumption) in m³/h and the relative density of the gas in question. The sections of the piping making up the system must be such as to guarantee a supply of gas sufficient to cover the maximum demand, limiting pressure loss between the gas meter and any apparatus being used to not greater than:

- 1.0 mbar for family II gases (natural gas);
- 2.0 mbar for family III gases (butane or propane).

An adhesive data plate is stuck inside the front panel; it contains all the technical data identifying the boiler and the type of gas for which the boiler is arranged.

2.3 CHARACTERISTICS OF FEEDWATER

It is absolutely essential that the water used for the central heating system should be treated in the following cases:

- Very extensive systems (with high contents of feedwater).
- Frequent addition of makeup water into the system.
- Should it be necessary to empty the system either partially or totally.

2.3.1 Filter on the gas pipe

The gas valve is supplied ex factory with an inlet filter, which, however, is not adequate to entrap all the impurities in the gas or in

gas main pipes.

To prevent malfunctioning of the valve, or in certain cases even to cut out the safety device with which the valve is equipped, install an adequate filter on the gas pipe.

2.4 SYSTEM FILLING

Filling must be done slowly so as to allow any air bubbles to be bled off through the air vents provided on the heating system.

The pressure of cold charging of the system, and the pressure of pre-pressurization of the expansion vessel, must correspond, or in any case must not be less than, the height of the static column of the system (e.g., for a static column of 5 m, the pre-pressurization pressure of the expansion vessel and the charging pressure must correspond to at least 0.5 bar).

2.5 CONNECTING UP FLUE

The flue for the atmospherical expulsion of the combustion products from natural draught appliances must meet the following requirements:

- Be gas-tight to the combustion products, waterproof and thermally insulated.
- Be built of materials suitable for keep resisting to normal mechanical stresses, heat, and the action of combustion products and their possible condensates.
- Follow a vertical path and not present any throttling throughout its entire length.
- Be adequately insulated to prevent phenomena of condensation or smokes cooling, in particular if located outside the building or in unheated ambiances.
- Be set at an adequate distance from combustible or easily inflammable material by means of an air gap or suitable insulating material.
- Have beneath the mouth of the first smoke duct a chamber for collecting solid material and any condensate; the height of the chamber must be at least 500 mm.

Access to the chamber must be guaranteed by means of an opening provided with an air-tight metal door.

- Have a circular, square, or rectangular internal cross section; in the case of square or rectangular sections, the corners must be rounded off with a radius of not less than 20 mm. However, hydraulically equivalent cross sections are allowed.
- Be equipped with a chimney-pot at the top, which must be outside the so-called back-flow zone, so as to prevent the formation of back-flow, which prevents free discharge of the products of combustion into the atmosphere.

Therefore, conform to the minimum heights indicated in fig. 4.

- Be devoid of mechanical means of suc-

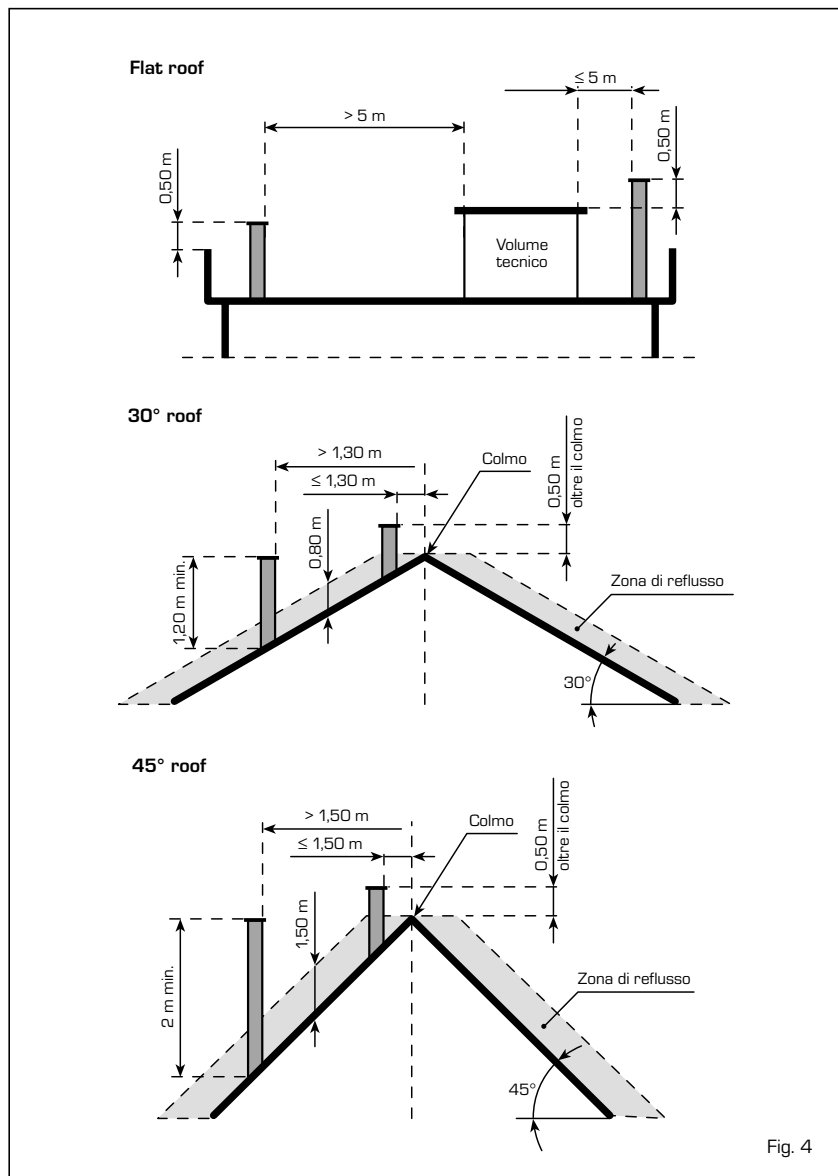

Fig. 4

The main factors to be taken into consideration for calculating the section are the heat input of the boiler, the type of fuel, the percentage of CO₂, the mass flow of smoke at nominal load, the temperature of the smoke, the roughness of the internal wall, and the effect of gravity on the draught pressure, which must take into account the external temperature and the altitude.

2.6 ELECTRICAL CONNECTION

The boiler is supplied with an electric cable. Should this require replacement, it must be purchased exclusively from SIME. The electric power supply to the boiler must be 230V-50Hz single-phase through a fused main switch, with at least 3 mm spacing between contacts.

The room stat must be class II as specified by standard EN 60730.1 (clean contact).

NOTE: Device must be connected to an efficient earthing system.

SIME declines all responsibility for injury or damage to persons, animals or things, resulting from the failure to provide for proper earthing of the appliance.

Always turn off the power supply before doing any work on the electrical panel.

2.6.1 Control system connection (optional)

In the electrical circuit a series of connectors are provided for the installation of an optional control system, marked by different colours black, red and brown (fig. 5). The connectors are polarised in such a way that the order cannot be inverted. To install the control system these connectors must be connected and jumpers 4-5 and 11-12 must be removed from the terminal board (marked in bold in fig. 6).

The control system allows for the use of sensors and environment units whose connectors, polarised and coloured, are found in a bag inside the control board.

tion located at the top of the pipe.
 - No overpressure should be present in a chimney that passes within or close up to inhabited rooms.

2.5.1 Sizing of flue

The correct sizing of the flue is an essential condition for efficient boiler operation.

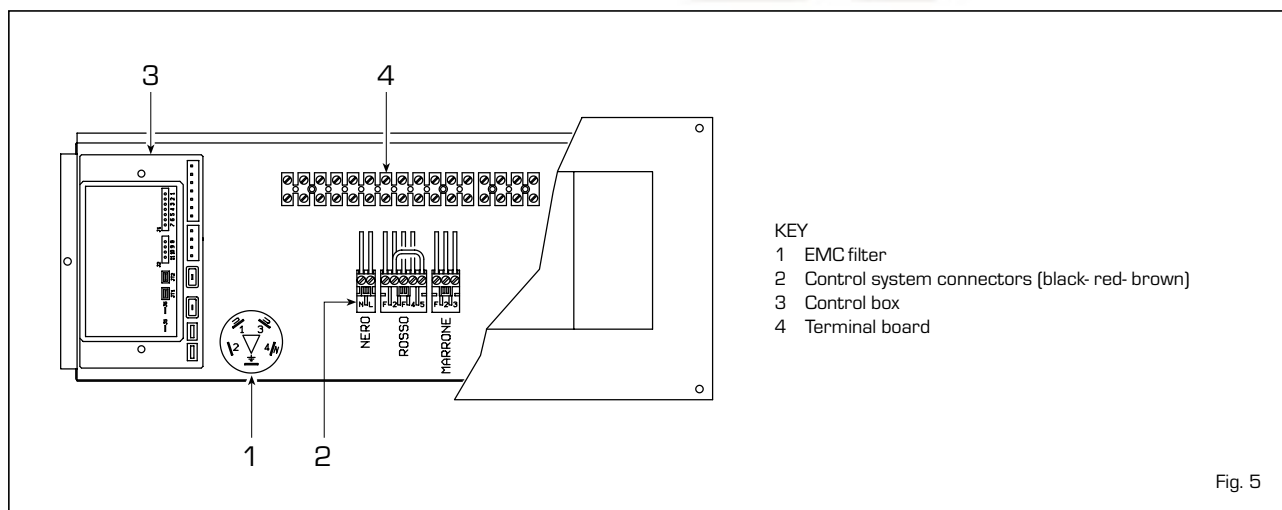

Fig. 5

- IT
- ES
- PT
- GB**
- FR
- BE
- GR
- RO
- RUS

2.6.2 Wiring diagram

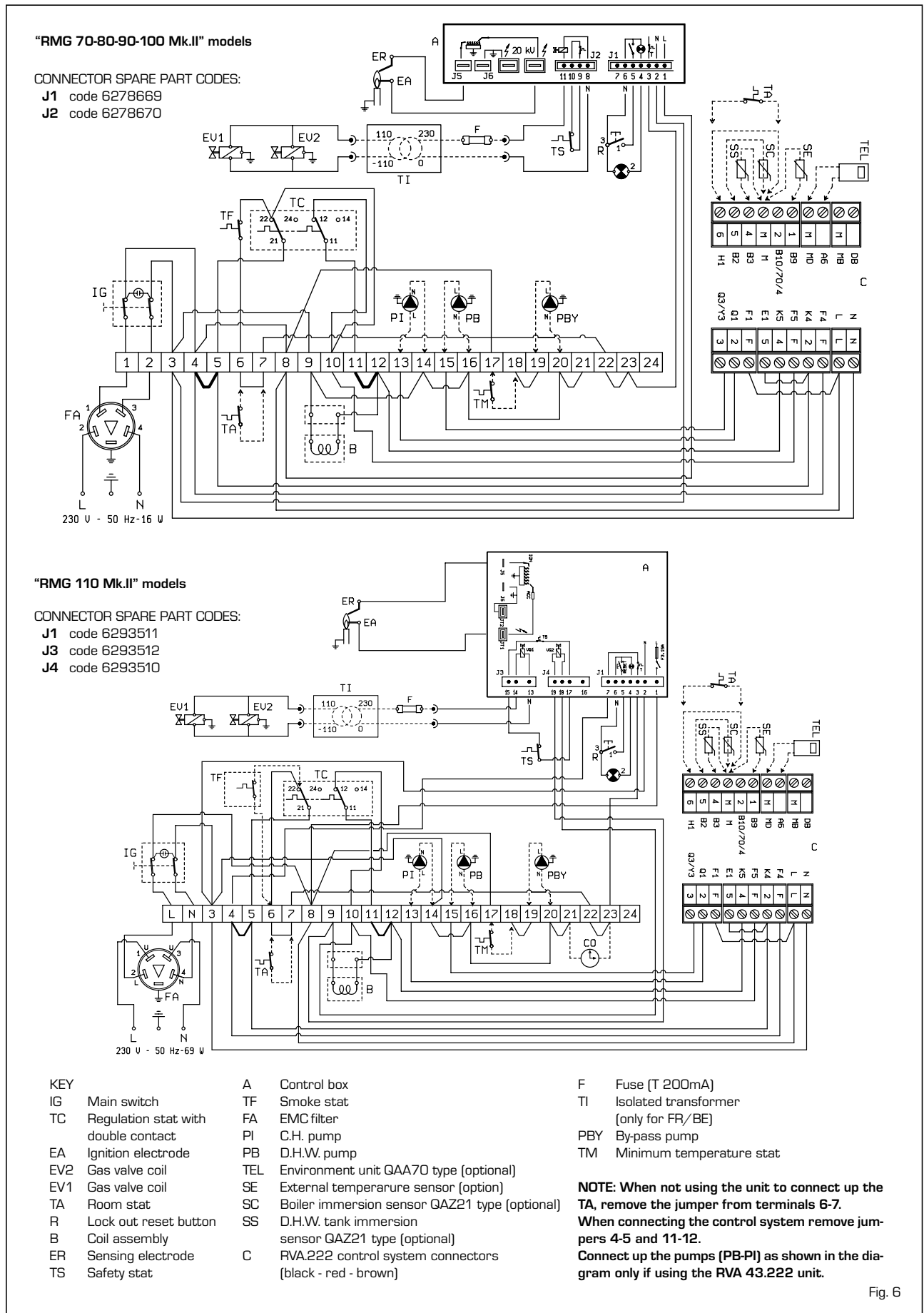

Fig. 6

2.7 CONTROL SYSTEM RVA43.222 (optional)

All the boiler functions can be operated by the optional control system code 8096303, supplied with external temperature sensor (SE), boiler immersion sensor (SC) (fig. 7). Another series of low tension connectors may be connected to the control system, these are used for the connection of the sensors and the environment unit (the connectors are to be found in a bag inside the control board). The bulb of the sensor of the external D.H.W. tank (SS), optional code 6277110, must be inserted in the hot water sheath and the boiler probe (SC) in the boiler sheath. To assemble the external temperature sensor (SE) follow the instructions given on the packaging of the sensor.

For the electrical connection refer to the diagram in fig. 6.

WARNING: to grant the correct operation of the plant set the boiler thermostat at the maximum value.

2.7.1 Characteristics and functions

"RVA 43" is realized as regulator of one boiler mono or bi-stadium or regulator of cascade connections to manage 16 boilers maximum.

Operating Efficiency

- Qualification or not of the heat production in the presence of integration with storage.
- Climatic control of the temperature of

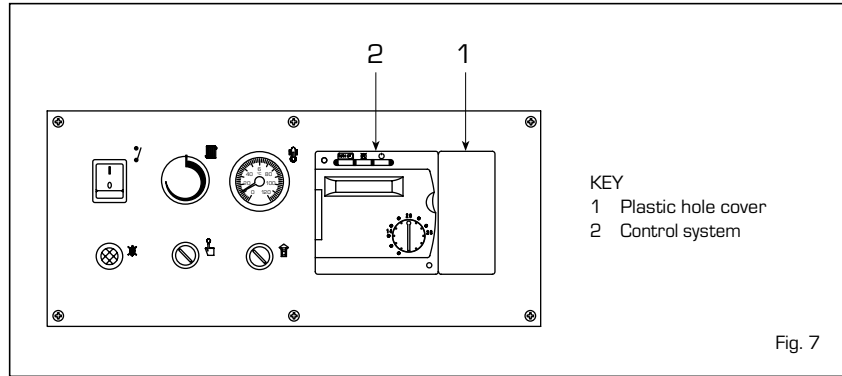

KEY
1 Plastic hole cover
2 Control system

Fig. 7

the boiler, with the possibility of room compensation.

- Operation of a direct heating circuit (with pump) for each regulator:
- Auto-adjusting function of the climatic curve on the basis of the thermal inertia of the building and the presence of "free heat" (with compensation).
- Optimising function of the ignition and turning off (speeded up heating and turning off before time).
- Saving function calculated on a daily basis according to the dynamic characteristics of the structures.
- Automatic summer/winter switching

Safety Functions

- Minimum and maximum adjustable temperature of return
- Differentiated antifreeze protection, hot water storage and plant.
- Protection from overheating of the boiler.
- Antiscuff protection of the pumps.
- Protection of the burner with minimum

operating time.

Operating functions

- Simplified starting procedure.
- All the settings may be carried out on the regulator.
- Standard for weekly programming.
- All the settings and operating regimes available on display and lit up leds.
- Relay and sensor test.

Hot water production

- Programming of day hours.
- Possibility of setting the minimum temperature for the hot water during the reduction period.
- Possibility of controlling the storage loading pump.
- Hot water circuit priority can be selected.

Other technical characteristics

- Easy connection with a digital environment unit (QAA70).

3 CHARACTERISTICS

3.1 CONTROL BOX

The "RMG Mk.II" boilers are provided with automatic ignition (without pilot burner). They are therefore equipped with FM 11 and DTM 12 electronic control and protection, with a built-in transformer, located inside the instrument panel protection box. Ignition and flame detection is controlled by two electrodes located on the burner:

These guarantee maximum safety with intervention times, for accidental switching off or gas failure, within 8 and 4 seconds (fig. 8).

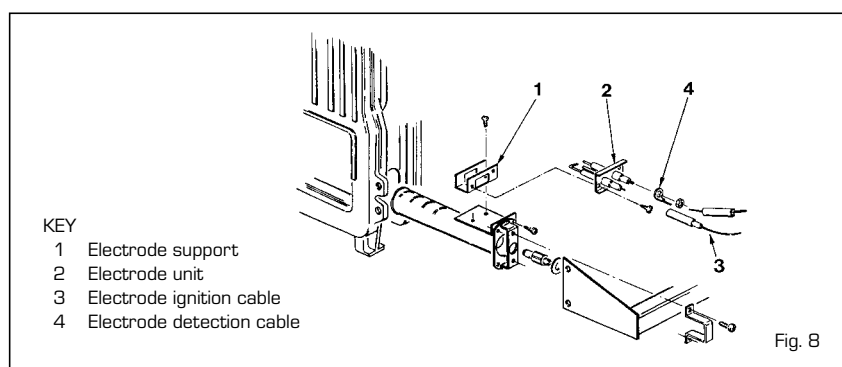

KEY
1 Electrode support
2 Electrode unit
3 Electrode ignition cable
4 Electrode detection cable

Fig. 8

- IT
- ES
- PT
- GB**
- FR
- BE
- GR
- RO
- RUS

3.1.1 Operating cycle

Before igniting the boiler, use a voltmeter to make sure that the electrical connection to the terminal block has been made properly, respecting the position of live and neutral, as shown in the diagram. Then press the switch on the control panel detecting voltage and lighting the led lamp.

The boiler is now ready to start working; a discharge current is sent to the ignition electrode through the programmer, and the gas valve opens at the same time.

Burner ignition normally takes place within 2 or 3 seconds. However, it is possible for ignition failures to occur, with consequent activation of signal indicating that the equipment has "locked out".

Failures may be due to one of the following causes:

- Gas failure

The control box runs through the cycle normally sending electric power to the ignition electrode. The electrode continues spark discharge for a maximum of 8 and 4 sec. If the burner does not ignite, the control box "locks out".

This may occur upon first ignition or after long periods of boiler lay-off when there is air in the pipes. It may be caused by the failure of the gas valve to open owing to a break in the electric coil.

- Ignition electrode fails to spark

In the boiler, only opening of gas to the burner is seen to occur. After 8 and 4 sec. the control box "locks out".

This may be due to there being a break in the wire of the electrode or the wire not being properly fastened to the terminal of the control box; or else, the transformer has burnt out.

- No detection of flame

The continuous spark discharge of the electrode is noted starting from ignition even though the burner is lit. After 8 and 4 seconds have elapsed, the sparks cease, the burner goes out, and the warning lamp indicating equipment "lock-out" lights up.

This occurs when the position of live and neutral has not been respected on the terminal block. There is a break in the wire of the sensing electrode or the electrode itself is earthed: the electrode is worn out and needs replacing.

The control box is faulty

When there is a sudden voltage failure, the burner shuts out immediately; when power supply returns, the boiler will start up again automatically.

3.1.2 Ionization circuit

The ionization circuit is to be checked using a dial-type micro-ammeter, or preferably a digital micro-ammeter with a 0 to 50 μ A scale. The micro-ammeter terminals must be series-connected to the wire of the sensing electrode. Under normal operating conditions, the value oscillates between 6 - 10 μ A. The minimum value of the ionization current for which the equipment can "lock out" is about 1 μ A.

In this case, make sure that there is a good electrical contact and check the degree of wear of the end part of the electrode and the corresponding ceramic protection.

3.2 REGULATION THERMOSTAT

"RMG Mk.II" boilers are equipped with a regulating thermostat with a double contact having differentiated setting (6 fig. 2).

This makes it possible to obtain a reduction of heat output before the burner goes out completely, by means of the coil assembly installed on the gas valve regulator.

This step-modulation system affords the fol-

lowing advantages:

- higher overall boiler efficiency;
- containment within acceptable values of the increase in temperature that takes place in the cast-iron body (heat inertia) when the burner goes out.

3.3 SMOKE SAFETY DEVICE "70 - 80 - 90 - 100 Mk.II" MODELS

This is a safety device against possible smoke emission into the ambience (8 fig. 2). The safety device goes into action by blocking operation of the gas valve when the return of the smoke into the ambience is continuous and in quantities that might constitute a danger.

To restart the boiler, the cover of the thermostat must be unscrewed and reset the underlying button.

Make sure the control panel is disconnected before carrying out this operation. Should the boiler continue to "lock out", it will be necessary to make a careful check on the flue pipe, making all the necessary modifications and amendments so that it can work properly.

3.5 SYSTEM AVAILABLE HEAD

The head available is shown in graph in fig. 9.

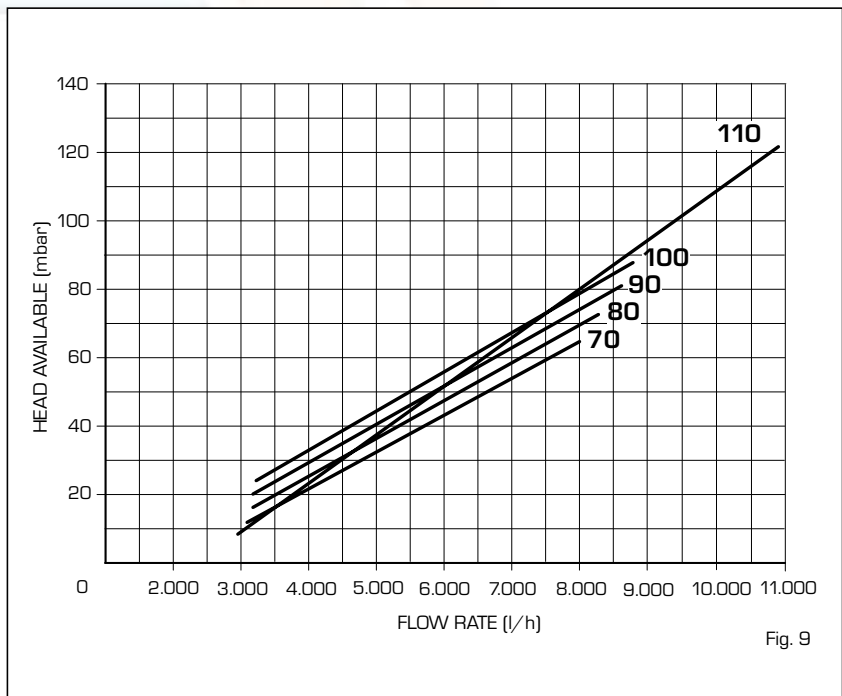

Fig. 9

4 USE AND MAINTENANCE

4.1 GAS VALVE (fig. 10)

"RMG Mk.II" boilers come equipped standard with a HONEYWELL VR 4605 C gas valve (for "70 - 80" models), VR 4605 CB gas valve (for "90 - 100" models) and VR 420 PB gas valve (for "110" models).

When the boiler is ignited the first time, it is always recommended to bleed the piping by using the pressure outlet upstream from the valve (7 fig. 10 - 9 fig. 2).

4.2 GAS VALVE ADJUSTMENT "VR 4605 C - VR 4605 CB"

Calibration of the operating pressures is done by SIME in the factory. Consequently they should not be altered. Only when you switch to another type of gas (butane or propane) is it permitted to alter the operating pressures.

It is essential that this operation be carried out exclusively by authorized technical staff.

When the working pressures have been adjusted, reseal the regulators.

When the gas pressures are to be reset, this must be done following a set order: first the maximum pressure and then the minimum.

4.2.1 Nominal pressure adjustment (fig. 11)

To set the maximum pressure, proceed as follows:

- connect the pressure column or a pressure gauge to the pressure intake located on the burner manifold;
- unscrew the screw (4) completely;
- set the knob of the thermostat to the maximum value;
- supply electric power to the boiler;
- loosen the locknut (1) and turn the connection (3):
to reduce the pressure, turn the connection counterclockwise; to increase the pressure, turn the connection clockwise;
- tighten the locknut (1);
- operate the main switch a number of times, making sure that the maximum pressure corresponds to the values given in **Table 1**.

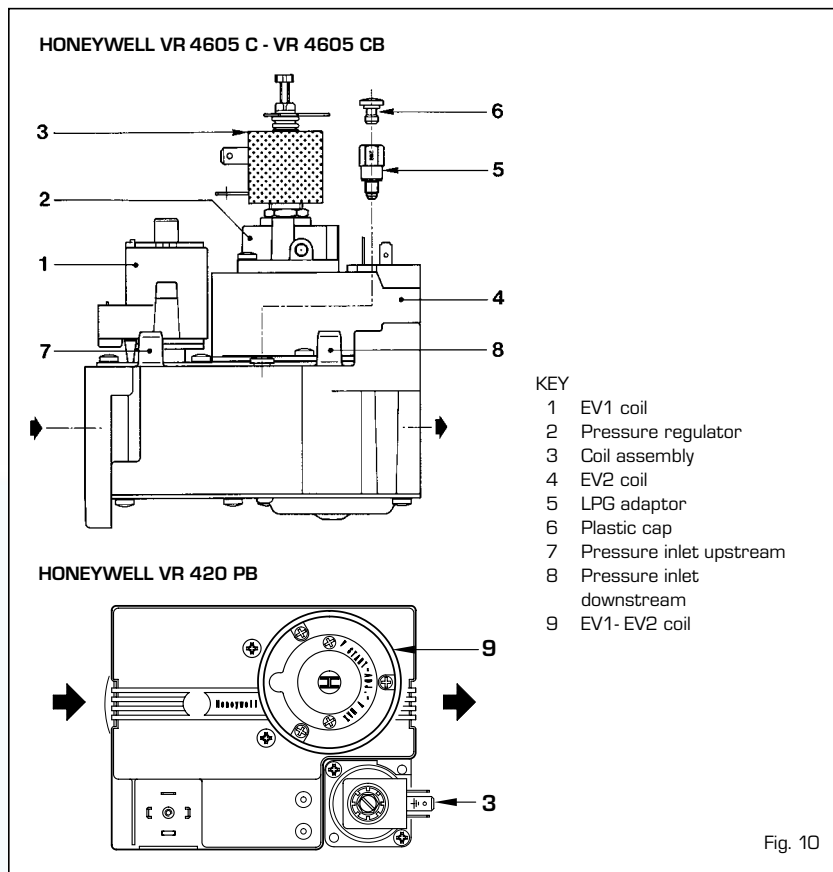
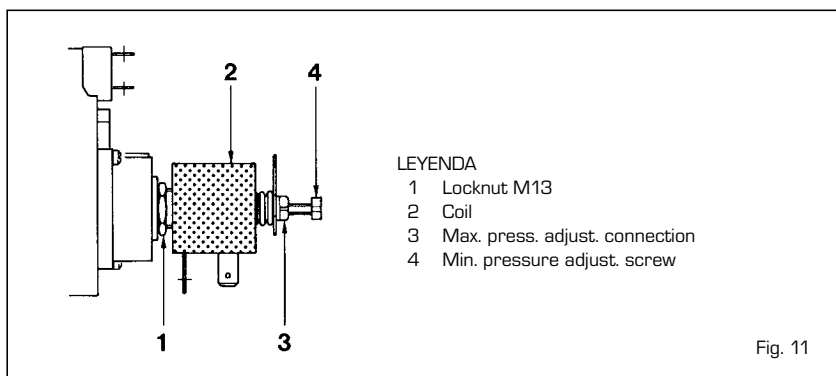

TABLE 1

		70 Mk.II	80 Mk.II	90 Mk.II	100 Mk.II	110 Mk.II
Methane - G20						
Burner max. pressure	mbar	9.3	9.1	9.3	9.3	9.3
Burner min. pressure	mbar	4.5	4.6	4.7	4.7	4.6
Butane - G30						
Burner max. pressure	mbar	25.2	25.4	25.1	25.1	25.6
Burner min. pressure	mbar	12.2	12.3	12.0	12.5	12.6
Propane - G31						
Burner max. pressure	mbar	32.6	30.2	30.0	32.7	34.3
Burner min. pressure	mbar	16.4	16.1	15.6	16.6	16.6

4.2.2 Reduced pressure adjustment (fig. 11)

To set the reduced pressure, proceed as follows:

- deactivate the coil (2) electric supply;
- switch on the boiler and after a short

period of operation at nominal output, turn the thermostat knob slowly towards the minimum position until you hear the click of the first contact of the thermostat;

- leave the knob in that position and, turning the screw (4), seek the minimum pressure value according to **Table 1** for the gas in question: to reduce the pressure, turn the screw counterclockwise; to increase the pressure, turn the screw clockwise;
- restore electric power to the coil;
- operate the main switch a number of times, making sure that the minimum pressure corresponds to the value given in **Table 1**.

4.3 GAS VALVE ADJUSTMENT "VR 420 PB"

Calibration of the operating pressures is



- IT
- ES
- PT
- GB**
- FR
- BE
- GR
- RO
- RUS

done by SIME in the factory. Consequently they should not be altered. Only when you switch to another type of gas (butane or propane) is it permitted to alter the operating pressures.

It is essential that this operation be carried out exclusively by authorized technical staff. When the working pressures have been adjusted, reseal the regulators. When the gas pressures are to be reset, this must be done following a set order: first the maximum pressure and then the minimum.

4.3.1 Nominal pressure adjustment (fig. 11/a)

Connect the manometer to the pressure test point located on the burner manifold, turn boiler ON, and wait until a steady reading on the manometer is obtained. Compare this reading with that shown in Table 1. If any correction is required, use an 8mm spanner on the high pressure adjuster (1) turning clockwise to increase, counter-clockwise to decrease the pressure.

4.3.2 Reduced pressure adjustment (fig. 11/a)

Turn the boiler OFF, and remove the plug from the High - Low Coil. Turn the boiler ON and wait until a steady reading on the manometer is obtained. Compare this reading with that shown in Table 1.

If any correction is required, use a 3.5 mm flat blade screwdriver to rotate the low adjust screw (2), turning clockwise to increase and counter-clockwise to decrease the pressure.

When all adjustments are completed, replace the plug on the coil, and the cap over the adjustment screws.

4.4 GAS CONVERSION

To convert to butane gas (G30) or propane gas (G31), the main nozzles must be replaced with another supplied in the boiler gas conversion kit and apply the LPG adaptor code 6248301 onto the gas valve (5 fig. 10). To adjust the operating pressures, refer to section 4.2.

When the working pressures have been adjusted, reseal the regulators.

After have ultimated the conversion of the boiler, please stick onto the casing panel the plate showing the relevant feeding gas which is included into the conversion kit.

NOTE:

After assembling all the gas connections, a test for gas tightness must be carried out using soapy water or special products.

Do not use naked flames. The conversion to different gas must be carried out exclusively by authorized technical personnel.

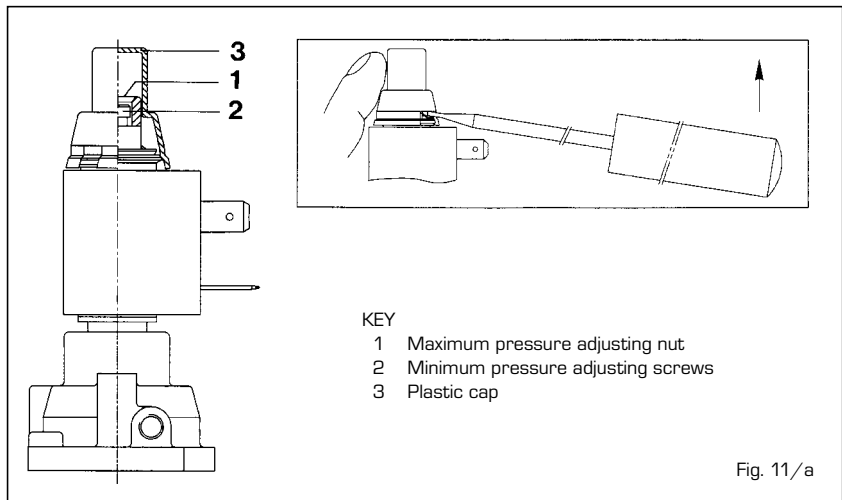

Fig. 11/a

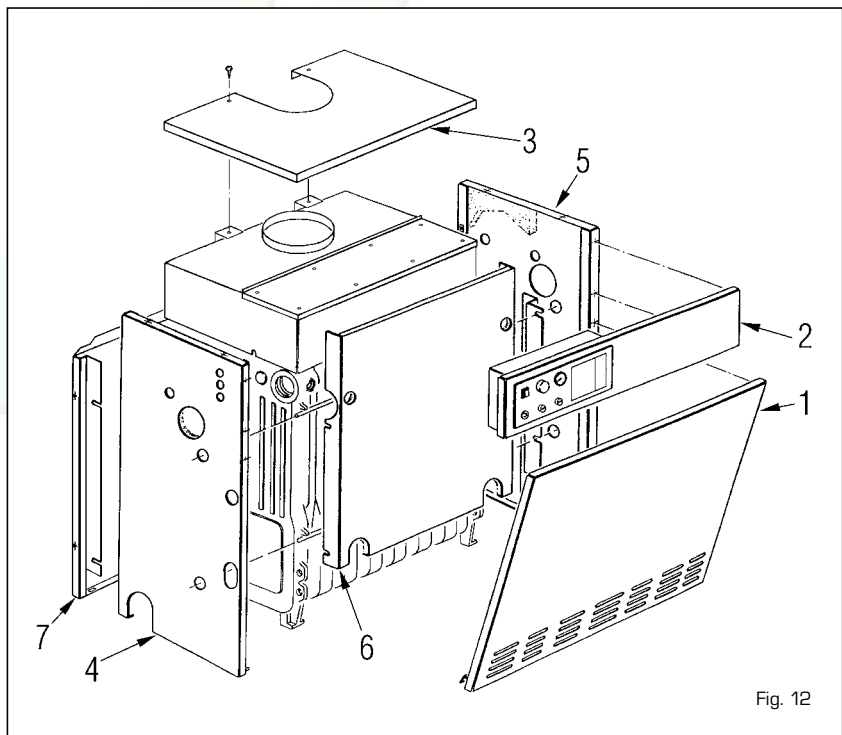

Fig. 12

4.5 SHELL DISASSEMBLY

Follow the steps described below to disassemble the shell (fig. 12):

- Remove the shell door (1) which is attached with pressure fit pins.
- To remove the cover (3) loosen the two screws that attach it to the flue gas chamber and lift.
- Remove the top front panel (2) placing it against the flue gas chamber.
- Disassemble the left side (4) unscrewing the nuts that attach it to the tie rods.
- Do the same operation to disassemble the right side (5).
- Remove the inner wall (6) by pulling it forward.
- Unscrew the nuts that secure the rear wall (7) to remove it from the tie rods.

4.6 CLEANING AND MAINTENANCE

At the end of each heating season, it is essential to have the boiler thoroughly checked and cleaned out. Proceed as follows:

- Turn the main switch off to stop electric power reaching the boiler and close the gas feed cock.
- Remove the shell door and cover.
- Remove the top panel of the flue gas chamber attached to it with self-threading screws.
- Remove the gas unit.
- Insert a special brush from the top into the rows of pins in the cast iron exchanger and move the brush up and down to remove the scales.
- Remove the burner from the nozzle header and aim a jet of air toward the inside

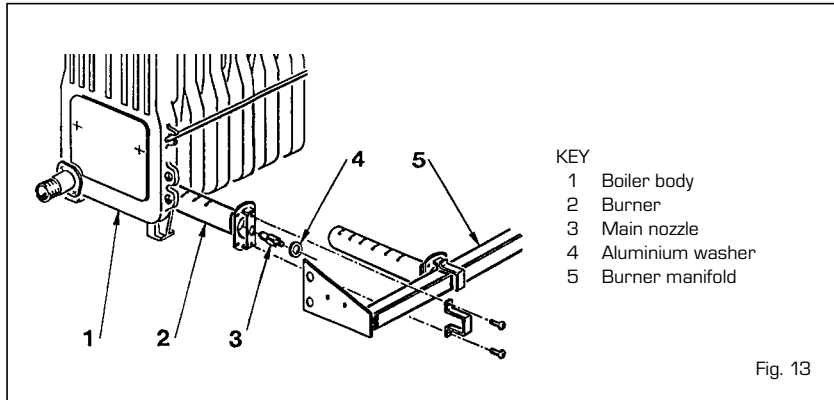

of the burners to remove any dust. Make sure that there are no scales on the top drilled part of the burners (fig. 13).

- Remove any scales from the bottom of the boiler and replace the items that were removed, checking the position of the gaskets.
- Check the chimney to make sure that the flue is clean.
- Check operation of the equipment and the main burner.
- After assembly of all the gas connections, these must be tested for soundness, using soapy water or appropriate products. **DO NOT USE NAKED FLAMES.**

Preventive maintenance and checking of efficient operation of equipment and safety devices must be carried out exclusively by authorized technical personnel.

4.7 FAULT FINDING

The main burner does not ignite.

- This means that the flue smoke stat has tripped off (point 3.3).
- Make sure power arrives to the gas valve.
- Replace the electric operator of the valve.
- Replace the valve.

The boiler reaches the set temperature, but the radiators do not heat up.

- Make sure there are no air bubbles in the system, if so purge from appropriate air vents.
- The room stat is too low or must be replaced if faulty.
- The connections of the room stat are not correct (make sure the cables are placed

on terminals 6 and 7 of the boiler terminal board).

Boiler operates only at nominal pressure and does not reduce pressure.

- Check whether there is voltage at both ends of coil.
- The coil has a break in the winding; replace.
- The rectifier card that supplies the coil is interrupted; replace.
- There is no differential on setting of the two contacts of the regulating thermostat; replace.
- Check calibration of reduced pressure adjusting screw of coil assembly.

The boiler gets dirty easily causing scaling of cast iron exchanger and cutting off of smoke stat.

- Check that the flame of the main burner is well regulated and that gas consumption is proportional to boiler output.
- Poor ventilation of premises where boiler is installed.
- Flue with insufficient draught or not meeting requirements.
- The boiler works at too low temperatures. Adjust the boiler thermostat to higher temperatures.

Thermostat switches boiler back on with too high temperature difference.

- Replace regulating thermostat since it is out of calibration.



- IT
- ES
- PT
- GB**
- FR
- BE
- GR
- RO
- RUS

WARNINGS

- In case of fault and/or incorrect equipment operation, deactivate it, without making any repairs or taking any direct action. Contact the nearest Authorised Technical Service Centre.
- The installation of the boiler and any servicing or maintenance job must be carried out by qualified personnel. Under no circumstances, the devices sealed by the manufacturer can be tampered with.
- It is absolutely prohibited to block the intake grilles and the aeration opening of the room where the equipment is installed.

LIGHTING AND OPERATION

BOILER IGNITION

Open the gas valve and press the main switch to ignite the "RMG Mk.II" boiler (fig. 14).

TEMPERATURE ADJUSTMENT

The heating temperature can be adjusted by turning the knob of the thermostat, which has a range of between 40°C and 85°C. The temperature setting can be checked on the thermometer. To ensure optimal boiler efficiency at all times, we recommend not to drop below a minimum working temperature of 60°C. In this way, any formation of condensate that might cause deterioration of the cast-iron body over time will be avoided (fig. 15).

SAFETY THERMOSTAT

The safety thermostat is of the manually resetting type and opens, causing the main burner to turn off immediately, whenever the temperature of 95°C is exceeded in the boiler. To restore boiler operation, unscrew the black cap and reset the button (fig. 16). **Should the appliance again "lock out", please approach the authorized technical staff.**

SMOKE SAFETY DEVICE "70 - 80 - 90 - 100 Mk.II" MODELS

This is a safety device against possible smoke emission into the ambience. The safety device switches off the gas valve when the return of the smokes into the ambience is continuous and then dangerous. To restart the boiler, the cover of the thermostat must be unscrewed and then press the underlying button (fig. 17). **Should the boiler "lock out" again, you must call the authorized technical staff.**

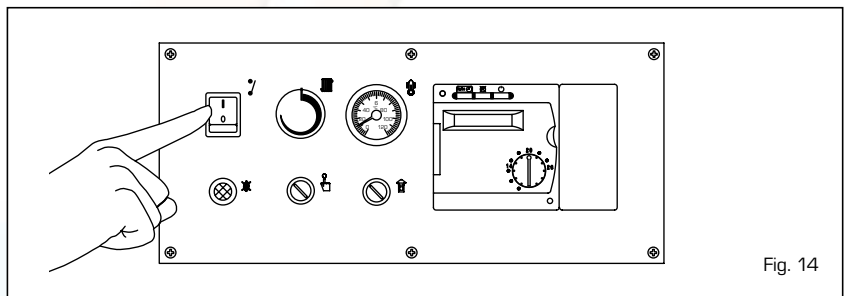

Fig. 14

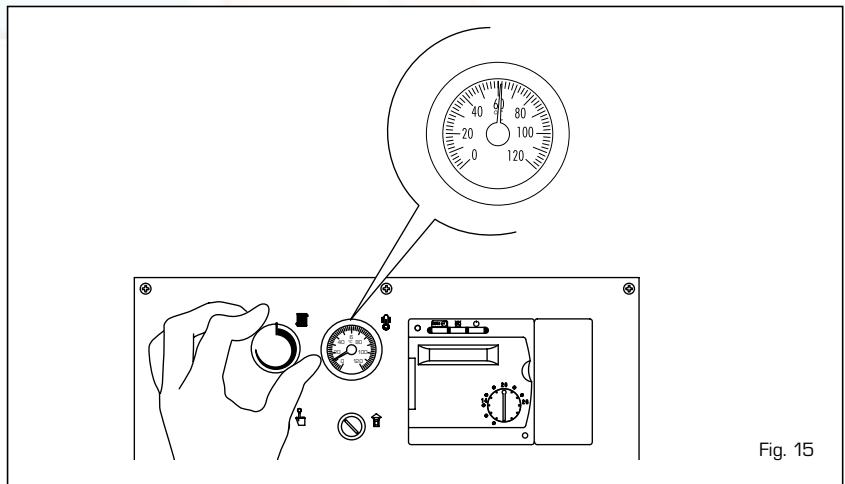

Fig. 15

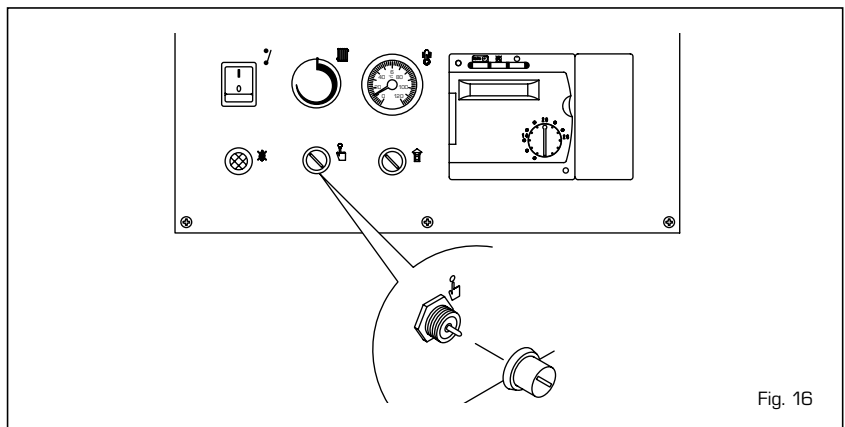

Fig. 16

LOCK OUT RESET OF THE CONTROL BOX

If the burner does not ignite, the red led on the reset button will turn on. Press the button to restart the boiler automatically (fig. 18). **Should the boiler "lock out" again, you must call the authorized technical staff.**

TURNING OFF BOILER

To turn off the "RMG" boiler completely, cut off electricity supply to the equipment by operating the main switch (fig. 14).

If the boiler is not going to be used for a lengthy period it is advised to turn off the electricity supply, close the gas cock, and if low temperatures are foreseen, empty the boiler and the hydraulic system to avoid breakage in the tubes due to the freezing of the water.

GAS CONVERSION

Should it be necessary to convert the appliance to a different gas from the one for which the boiler has been equipped, approach the technical staff.

CLEANING AND MAINTENANCE

At the end of each heating season, it is essential to have the boiler thoroughly checked and cleaned out.

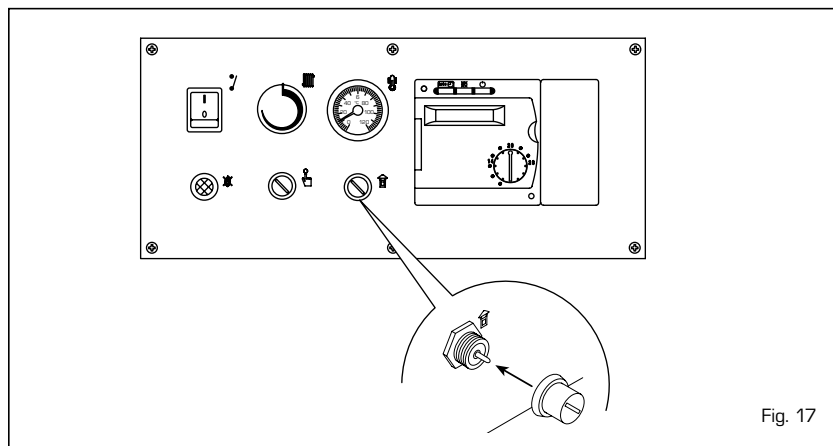

Fig. 17

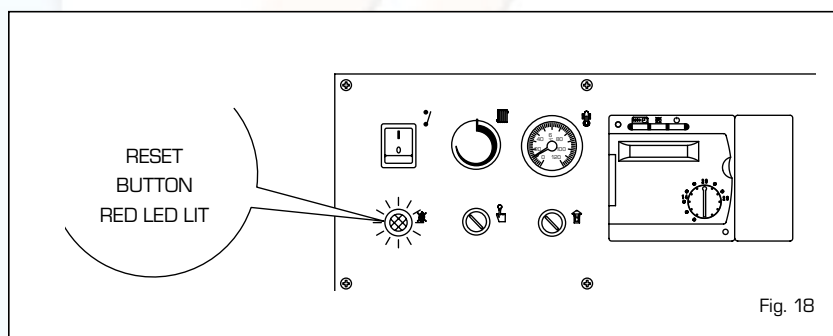

Fig. 18

Preventive maintenance and checking of the efficient operation of the equipment and safety devices must be carried out exclusively by the authorized technical

staff. The boiler is supplied with an electric cable. Should this require replacement, contact exclusively with the authorized technical staff.

CONTROL SYSTEM

In order to get the highest potential out of the "RVA 43.222" regulator follow the instructions given below:

TO TURN ON THE HEATING

- Turn on the main switch.
- Set the correct hour of the day and the day of the week.
- Place in automatic mode with the button .



TO SET THE HOUR

Select the line	Display	Set the regulation with the buttons	
	1		hour of the day
	2		day of the week



HOW TO USE THE AUTOMATIC MODE

In the automatic mode the temperature of the room is regulated on the basis of the periods of heating chosen.



- Push the button .

NOTE: Select the heating periods according to one's daily requirements; in this way it is possible to significantly save on energy.

TO ACTIVATE CONTINUOUS HEATING

The continuous heating mode keeps the temperature of the room at the set level via the regulating knob.



- Push the "Continuous Operation" button .
- Regulate the room temperature with the regulating knob.

TO SET THE STANDBY MODE (when the user is away for a long period of time)

The standby mode keeps the temperature of the room at the level of antifreeze protection.





- Push the "Standby mode" button .



MEANING OF THE SYMBOLS

On the display a few of the symbols indicate the current operating state. The appearance of a line under one of these symbols signals that the corresponding operating state is "active".



 Heating at the nominal temperature (regulating knob)

 Heating at reduced temperature (line .

 Heating at antifrost protection temperature (line .

NOTE: For further information on the symbols and the operating state refer to the detailed description of the heating plant.

TO VARY THE HOT WATER PRODUCTION

The production of hot water can be activated or deactivated by the push of a button.





- Push the button "Hot water" .

IF THE HOT WATER IS TOO HOT OR TOO COLD

Select the line	Display	Set the desired temperature	
	13		°C



IF THE ROOMS ARE TOO HOT OR TOO COLD



- Check that current operating state on the display.
- In the case of **nominal temperature** . Increase or reduce the temperature of the room with the regulating knob.
- In the case of **reduced temperature** .



Select the line	Display	Change the temperature with the buttons	
	14		°C



















NOTE: After each regulation wait at least two hours for the new temperature to expand through the room.

TO CHANGE THE HEATING PERIODS

Select the line	Display	Pre-select the weekly block or the single day	
	5		1-7 = week 1 = Lu/7 = Do



With reference to the day chosen set the changes as following:

Period requested	Push button	Display	Set hour	For °C
Period 1	Start 	6		
	End 	7		
Period 2	Start 	8		
	End 	9		
Period 3	Start 	10		
	End 	11		

NOTE: The heating periods automatically repeat on a weekly basis.

To this end select the automatic mode.

It is possible to reset the standard programme on line 23 by pushing the buttons + and - at the same time.

IF THE HEATING DOES NOT WORK PROPERLY

- Refer to the detailed documentation on the heating system, following the fault finding instructions.



TO MEASURE GAS COMBUSTION

- Push the "chimneysweep" button . The heating will work according to the level requested.



HOW TO SAVE ENERGY WITHOUT FOREGOING ON COMFORT

- A temperature of around 21°C is advised in the rooms that are used. Every degree above this will increase heating costs by 6-7%.
- Aerate the rooms only for a brief period, opening the windows completely.
- In the rooms that are not used place the regulating valve in the antifreeze position.
- Leave the space in front of the radiators free from obstructions (remove furniture, curtains...).
- Close windows and blinds to reduce dispersion of heat.

