

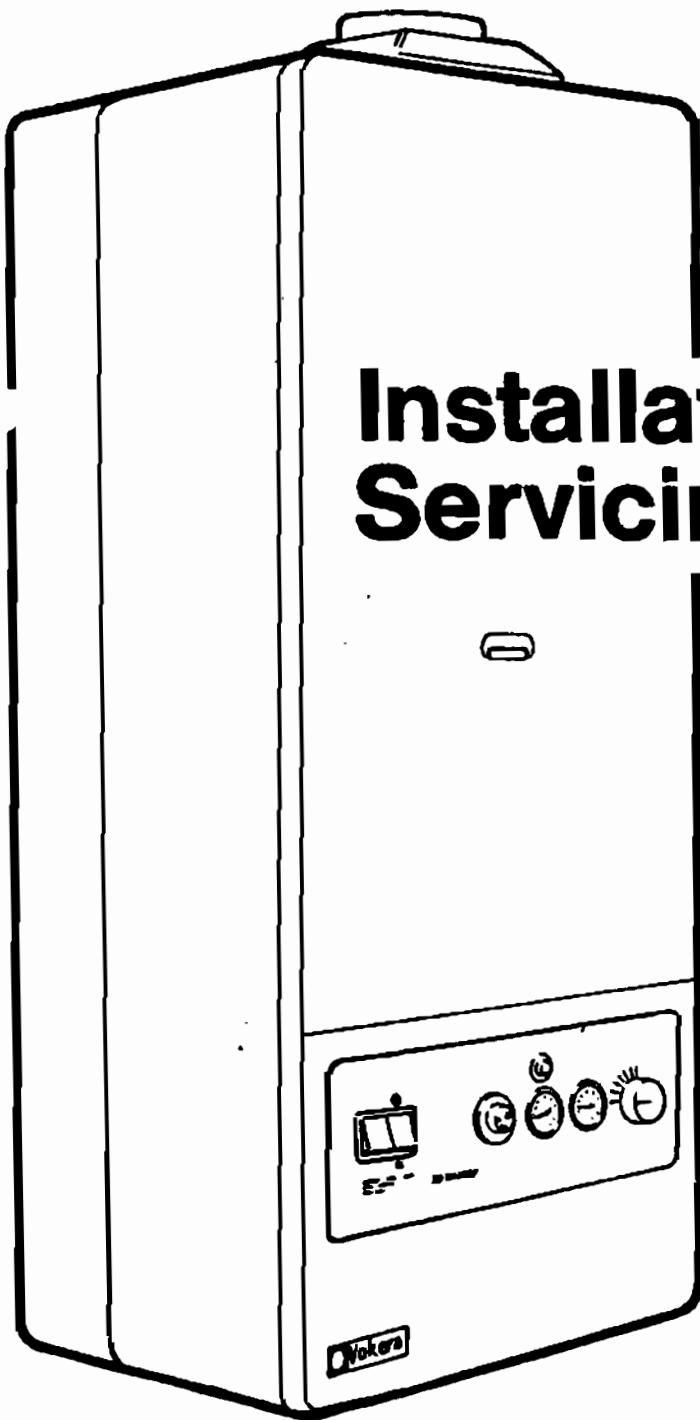

Vokèra

21-84 M.C.F.



Installation and Servicing Instructions

Leave these instructions
adjacent to the
Gas Meter

This Appliance is for use
with Natural Gas only

SECTION 1 INTRODUCTION

The Vokera 21/84MCF is a combined central heating and domestic hot water appliance. By design, it incorporates a circulating pump, 3 port valve, expansion vessel, safety valve temperature gauge and pressure gauge.

It is produced as an open flued, category 1N appliance suitable for wall mounting applications only.

The appliance is designed for use with a sealed heating system requiring pumped

circulation, and is not intended for installation on an open vented system.

A range-rating facility is incorporated in the boiler for the central heating system in conjunction with high/low burner control. The domestic hot water (dhw) service utilizes a differential water pressure control combined with a 3-port diverter valve to give hot water priority.

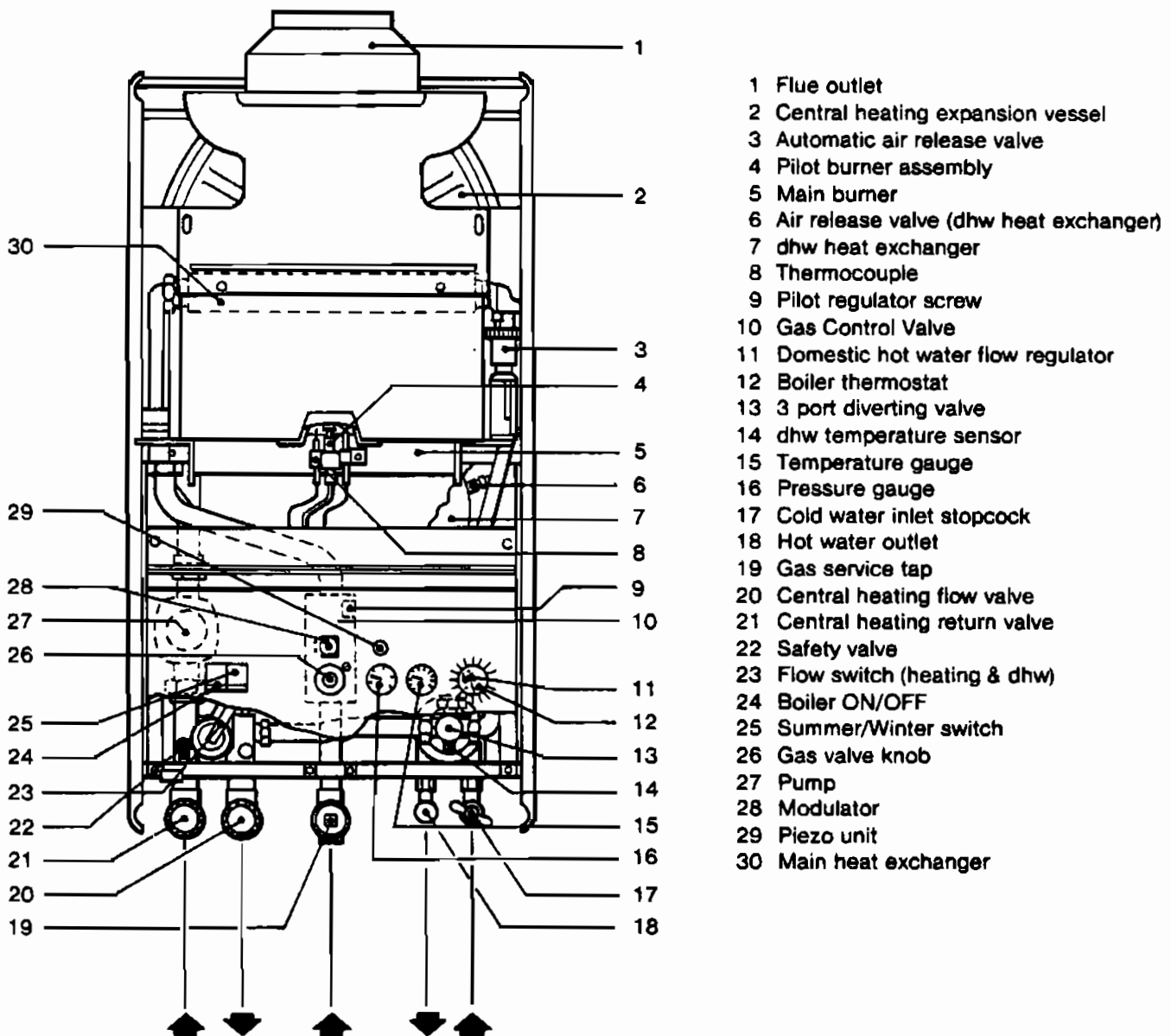
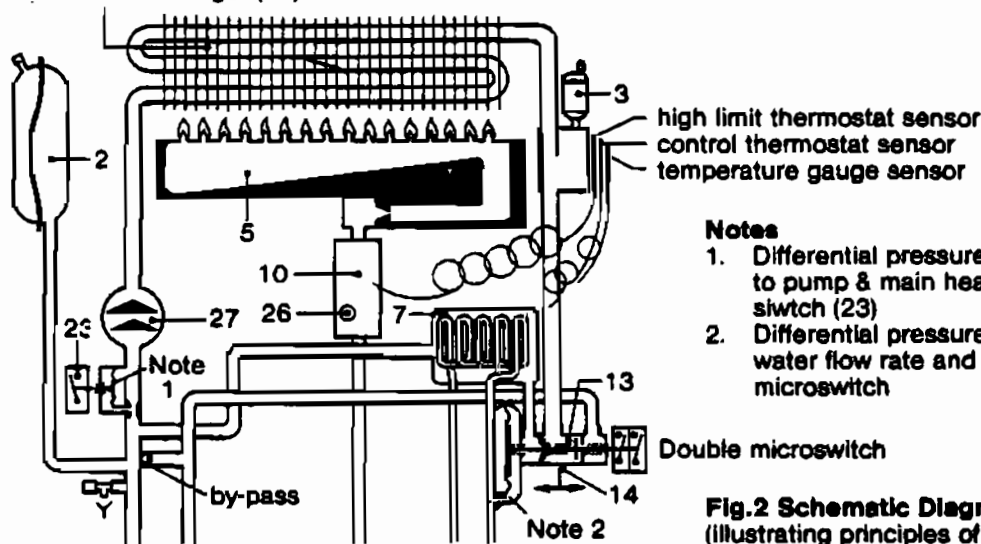

Fig.1 General Layout

Main heat exchanger (30)



- Notes**
1. Differential pressure unit. Senses water flow rate to pump & main heat exchanger and operates flow switch (23)
 2. Differential pressure unit. Senses domestic hot water flow rate and operates 3 port valve/double microswitch

Fig.2 Schematic Diagram
(illustrating principles of Operation)

SECTION 2 DESIGN AND OPERATING PRINCIPLES

2.1 Fig.1 illustrates the general layout of components, and fig 2 the principles of operation further details are given in section 9

2.2 Central Heating Mode

- 2.2.1** With the on/off switch (24) in the ON position and the SUMMER/WINTER switch (25) in the 'Winter' position the pump (27) circulates water through the heat exchanger (30) and around the central heating system.
- 2.2.2** If sufficient water passes through the differential pressure control in the boiler circuit, the flow switch (23) closes to activate the burner control circuit.
- 2.2.3** Once the burner is alight it operates at high flame until the thermostat (12) operates on first stage when it causes the burner to reduce to low flame. Depending on load the heating flow temperature will either rise and cut off the burner (by operating the second stage of the thermostat) or fall and re-establish high flame.
- 2.2.4** The high flame in the central heating mode need not be equal to the maximum heat input rating but can be reduced by the installer to suit the designed system output (range rating).

2.3 Hot Water Mode

- 2.3.1** The hot water mode will always function regardless of the SUMMER/WINTER switch position provided that the switch is 'ON' and a draw-off tap is opened.
- 2.3.2** The differential pressure unit (dhw) is operated by a specified minimum flow of

water through the appliance. When the minimum flow is achieved the three port valve operates and diverts water through the dhw heat exchanger, instead of the central heating system.

- 2.3.3** The domestic draw-off water passes through the coil in the dhw heat exchanger and is heated by the diverted primary water.
- 2.3.4** In this mode, the 2-stage thermostat is inoperative and the gas flow is modulated between maximum and minimum by a temperature sensor (thermistor) located in the 3-port valve where it senses primary water temperature.
- As domestic hot water temperature increases heat transfer decreases and the primary water temperature tends to rise. This is sensed by the thermistor and the control circuit causes the gas flow rate to be reduced.
- 2.3.5** If the draw-off tap is manipulated so that flow rate reduces the domestic water temperature increases. If flow rate drops below the specified minimum the differential pressure unit (dhw) reverses (see 2.3.2) and the burner cuts out.
- 2.3.6** In both the central heating and hot water modes safe operating is ensured by
- (a) differential pressure units in both primary and dhw circuits which prevent burner operation if water flow rates are too low
 - (b) a high limit thermostat, which interrupts the flame supervision circuit and
 - (c) a pressure relief valve.

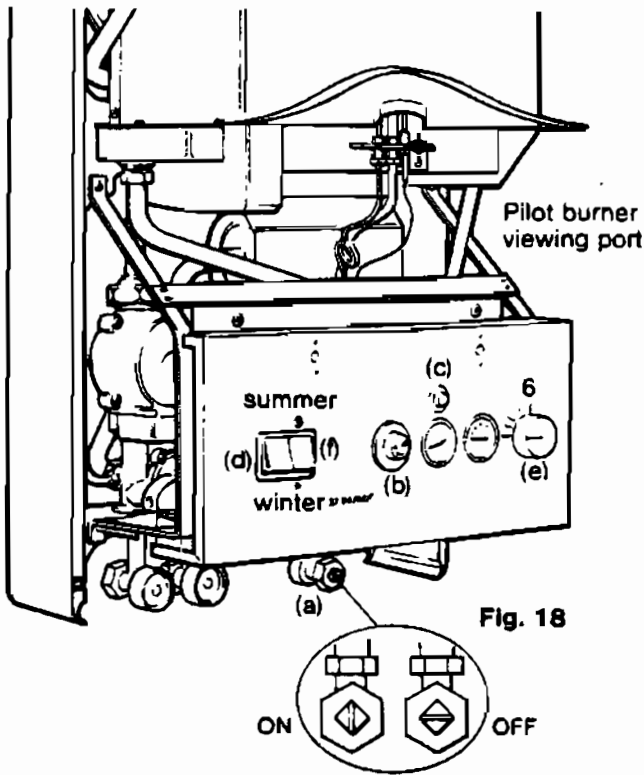

Fig. 18

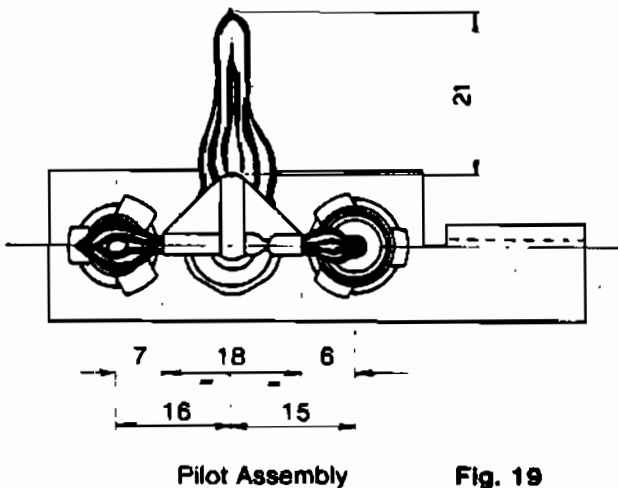

Fig. 19

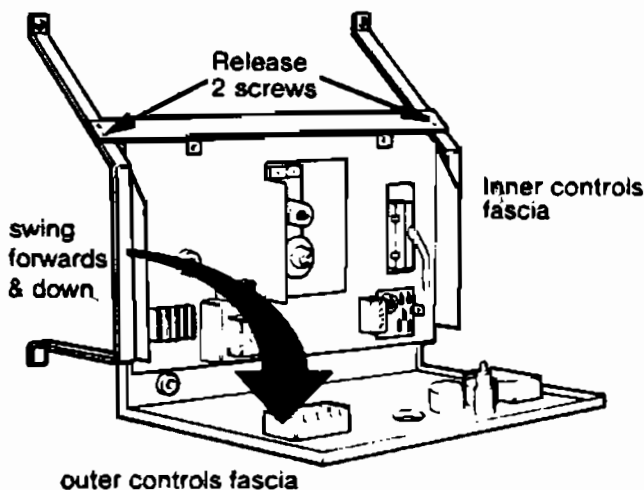

Fig. 20

6.5.5 Once the pilot burner ignites stop pressing the Piezo unit button but continue to hold in the gas control knob for a further 15 seconds before releasing. The pilot flame should remain alight and envelope the thermocouple (see fig 19). If it goes out wait 3 mins and repeat from 6.5.4

6.5.6 Refer to fig 19 and check that the pilot flame is correctly set. If it is necessary to adjust the pilot refer to cl. 6.6.8.3 for access instructions, Fig 22 for location of regulator screw. Turning clockwise decreases flame.

6.6 Lighting the boiler and main burner adjustment (fig 18)

6.6.1 If external controls are fitted ensure that they 'call for heat'. (The commissioning of the appliance may be facilitated by disconnecting external controls and linking terminals 4 & 5 on the appliance terminal block (for access procedure refer to clauses 5.11.2 and 6.6.8-3)

6.6.2 Turn on electricity Supply at the main isolator.

6.6.3 Switch the boiler on/off switch (d) to position 1. ON

6.6.4 Set the thermostat (e) to setting 6

6.6.5 Set the Summer/Winter switch (f) to Winter position (☼ symbol)

6.6.6 Check that the pump regulator switch (fig 38) is still in the *factory set* position 3

6.6.7 The main burner should now light. If it fails to do so, turn to the fault finding charts in Section 9 to trace the cause.

6.6.8 Check Burner pressures (figs 20 & 21)

6.6.8.1 The heat inputs for maximum and minimum burner rates are *factory set* but it is necessary to check them when the boiler is in operation

6.6.8.2 The maximum output for the central heating mode may be reduced by a site adjustment to suit the system load. This in no way affects the appliance maximum which is always obtained in the domestic hot water mode.

6.6.8.3 Open the outer controls fascia as instructions in clause 5.11.2 then open inner fascia by releasing 2 screws on side frames and swinging fascia outwards and downwards.

6.6.8.4 Slacken sealing screw in the pressure test point ½ turn anti-clockwise ☺ and attach a suitable pressure gauge (fig 21)

6.6.8.5 The pressure reading for high flame should be 13.3 mbar (5.3in wg). If the reading obtained is different, adjustment must be made following the procedure given in clause 8.11.4.7

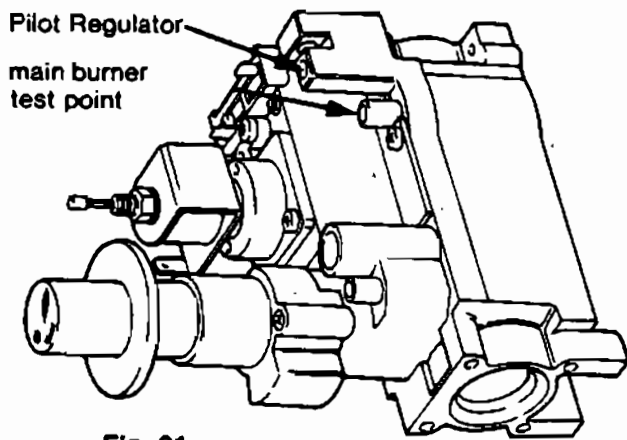

Fig. 21

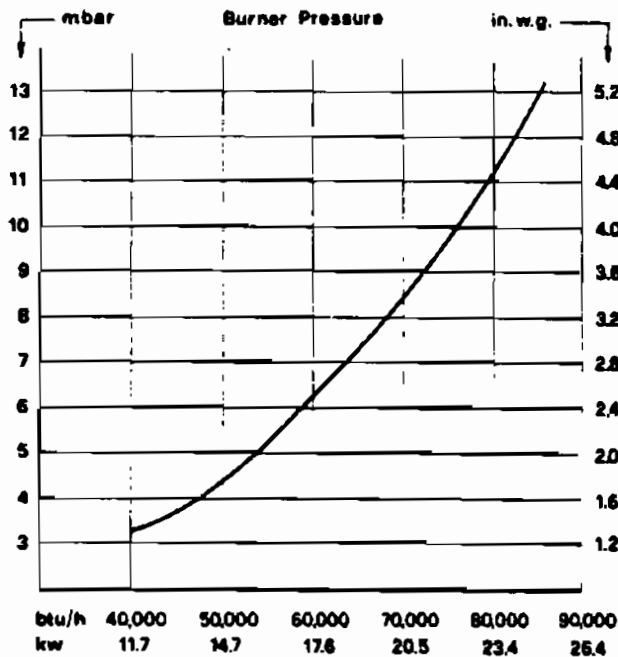

Fig. 22 Central heating output

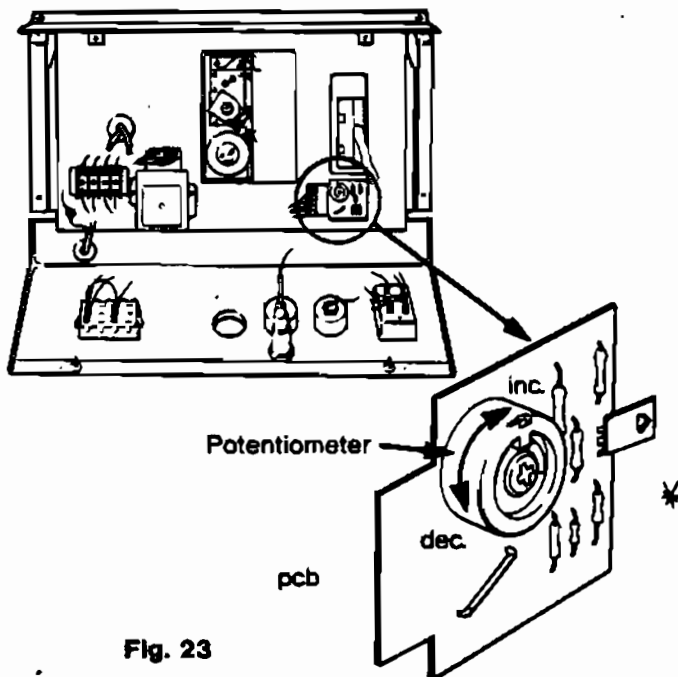

Fig. 23

6.6.8.6 If the boiler temperature is above 60°C turn the thermostat to minimum setting to establish low flame

(If low flame cannot be established in this way, turn off the main electricity supply, and transfer the pink cable on terminal 1 of the boiler thermostat to terminal 1A (see fig 47) switch on electricity.

6.6.8.7 When low flame is established, the gauge reading should be 3.3 mbar (1.3in wg) if it is different adjustment must be made as instructed in clause 8.11.4.7

6.6.8.8 If thermostat connexion has been transposed to obtain low flame (cl 6.6.8.6) turn off electricity supply and replace the cable on terminal 1

6.6.8.9 Setting maximum rate for central heating

The rate can be set at any value between the maximum and minimum rates established above.

First refer to fig 22 to establish the burner pressure needed to give the heating output you need (e.g. for 17.6kW a pressure of 6.25mbar is needed).

Then with boiler at full flame in heating mode use a screw driver to adjust the potentiometer (fig 23) anti-clockwise until the required pressure registers on the gauge.

Once the pressure has been fixed it must be indelibly recorded on the data badge (This is to ensure that the requirement is retained after any subsequent service operation which affects pressure settings).

6.6.9 Checking flue System

The flue system should be visually checked for soundness, then tested for clearance of combustion products as detailed in BS 5540 part 1.

6.7 Checking boiler Control Thermostat

Allow the system to warm up and manipulate the thermostat up and down at various points to ensure it switches from 'high' to 'low' and from 'low' to 'off' as the setting lowered. (Scale range covers approx. 55°C - 85°C)

6.8 Checking the operation of the flame failure Device

Refer to clause 6.5.6 and adjust the pilot regulator until the flame goes out.

With loss of the pilot flame, after a short delay the main burner should extinguish. re-establish the pilot flame as instructed in clauses 6.5.1 - 6.5.6

SECTION 9 FAULT FINDING

9.1 Preliminary electrical system checks as contained in the B.G.C. multimeter instruction book are the first electrical checks to be carried out during a fault finding procedure. On completion of any service/fault finding task which has required the breaking and remaking of electrical connections, then the checks A, Earth Continuity, C, Polarity and D, Resistance to earth must be repeated.

The following flow diagrams suggest the logical sequence of steps for fault finding.

They are not exhaustive but cover all that can reasonably be carried out on site by the installer.

Acquaintance with the functional sequence will prove helpful for some and this is included for reference. As a further help, the role of each part is briefly described.

Also included in this section are wiring diagrams and schematics to assist in fault location as described in the text.

9.2 Sequence of functions

When following this sequence refer to figs 2 and 50-55

Pilot flame alight

Main switch On provides 240v at terminal 7 (on/off switch)

On/off switch 'mode' provides current to P

Heating Mode

Summer/Winter switch 'Winter' energised 3 on switch and 4 & 5 on terminal block and 1 on flow switch

Pump starts

Water circulation through heating manifold differential section operates single micro switch (flow switch) current to 3 on flow switch and via fuse to 2 on transformer 15v d.c. from 5 on transformer via gas valve operator through 2A - P2 on thermostat. This completes the circuit and **Gas Valve opens. Burner lights**

15v d.c. from 6 on transformer through modulator coil to 1 on p.c.b. and through R3 - R2 when 1-P1 on boiler thermostat closes. Maximum voltage is applied to coil and gas valve closes down to minimum gas rate (fixed at factory but see cl 6.8.8).

R2 is an adjustable potentiometer which fixes minimum voltage and so maximum gas rate. This latter adjustment is made on-site to establish maximum central heating output (Range Rating).

If heating load is less than max. Pt-1 will cycle closed/open, switching burner from low to high flame and vice versa.

If boiler temp. continues to rise (on low flame) 2nd stage switch P2-2A breaks and **gas valve closes**

Hot Water Mode

If a draw-off tap is opened cold water flow through the differential pressure device operates the 3-port diverting valve permitting boiler flow to the Domestic Hot Water heat exchanger only. The 3-port valve spindle extends to operate the double micro-switch.

The 1st pole (marked 'A' on fig 53 & 54) of this switch 'makes' 1-3 overlinking all heating switches to start pump and burner as in the heating mode.

The 2nd pole (marked B) changes over from 1-2 to 1-3 which disables Pt-1 (1st stage/low flame) and overlinks P2-2A of boiler thermostat, opening gas valve.

The voltage to the modulator coil is not now dependent on R2 but on the temperature sensor (NTC thermistor)

The thermistor resistance varies with its temperature as shown in fig. 50 and it is uniformly low at low temperature. The effect is to close transistor TR1. P.C.B. terminals 1 & 3 have minimum voltage and therefore max. gas flows to burner.

As boiler flow temperature rises to 80°C (approx) the thermistor resistance rises steeply. Current flows through R4 - R5 - DZ1 & TR1 giving max. voltage at 1 & 3 and so minimum gas flow.

As hot water draw-off rate reduces and/or its temperature rises heat transfer will reduce and boiler temperature will tend to rise. The thermistor responds, to regulate the gas rate according to demand.

The design ensures that, with a properly functioning appliance, minimum water flow rate will fully absorb heat of minimum gas rate without dangerous overheat.

Any malfunction causing overheat will increase boiler temperature to the point where the high limit thermostat will trip the safety circuits, close the gas valve and extinguish the pilot.

Extremely low hot water draw-off rates, which would also cause high temperatures at the tap, are not normally possible since the pressure differential device would deactivate and switch off burner.

FAULT FINDING STEP 1

CHECK ELECTRICAL SUPPLIES & CONNECTIONS

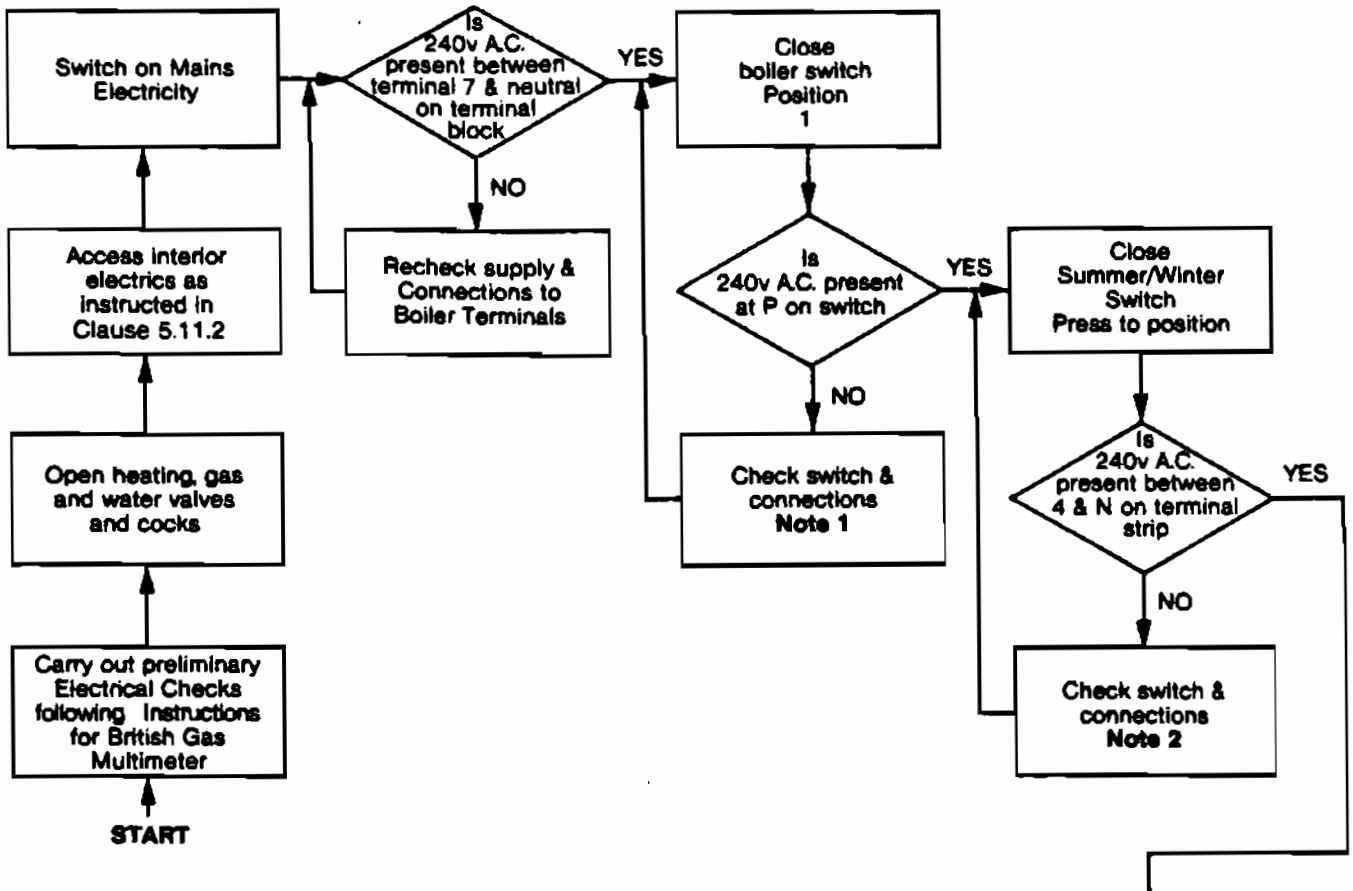

Note 1 The simplest check is to overlink 7 & P and proceed to next step to prove S/W switch.
Note 2 Overlink P-3. If current at 4, switch is faulty. If no current at 4, check internal wiring undamaged.
 To renew switch, follow instructions in clause 8.19.6 of service book.

Proceed to:-
Step 2 Check of flame failure device and thermocouple
Step 3 Check operation of heating system
Step 4 Check operation of hot water system

FAULT FINDING STEP 2

CHECK GAS CONTROL PILOT BURNER FLAME SUPERVISING SYSTEM

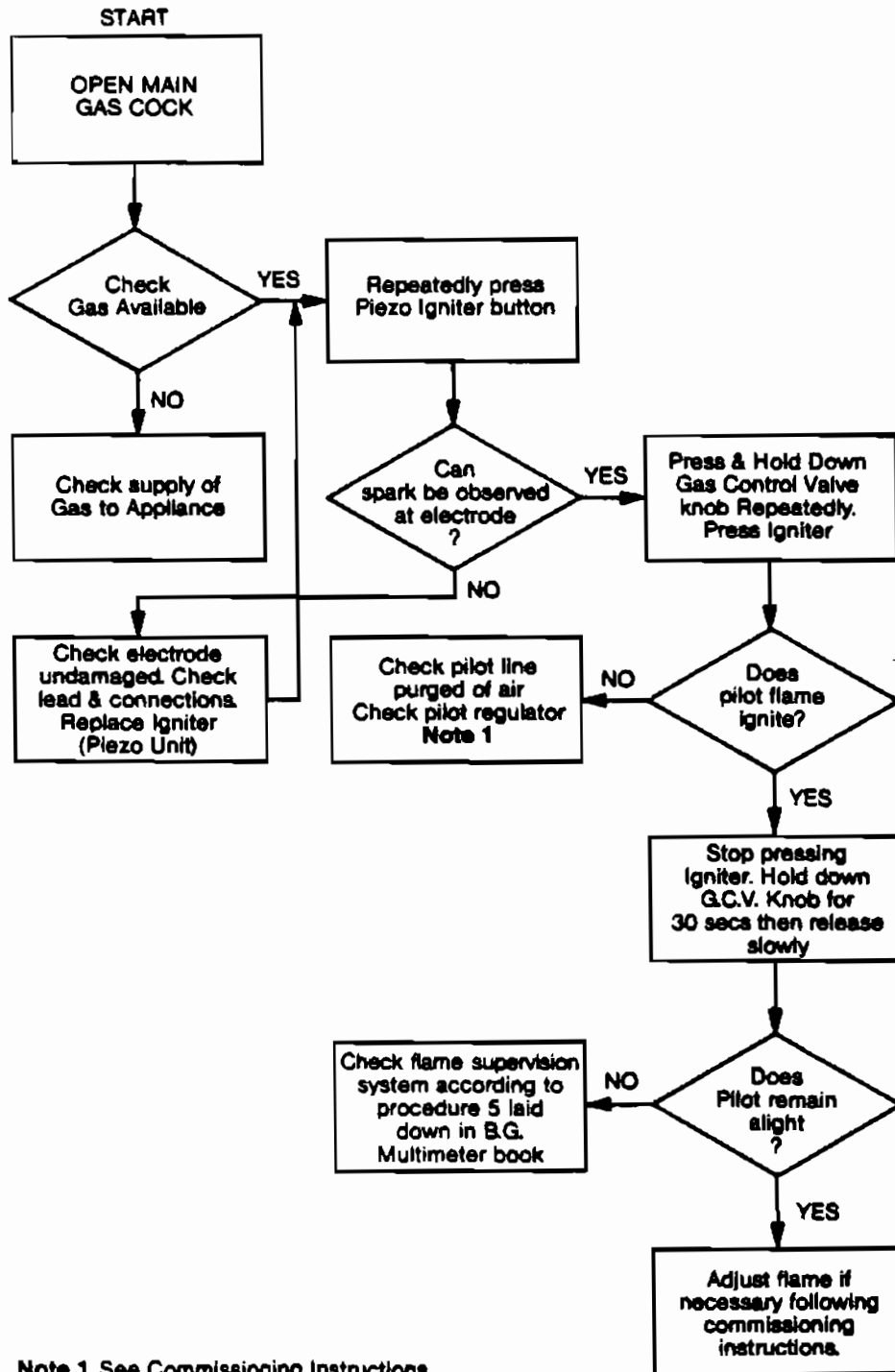

FAULT FINDING STEP 3

CHECK OPERATION OF CENTRAL HEATING FUNCTION

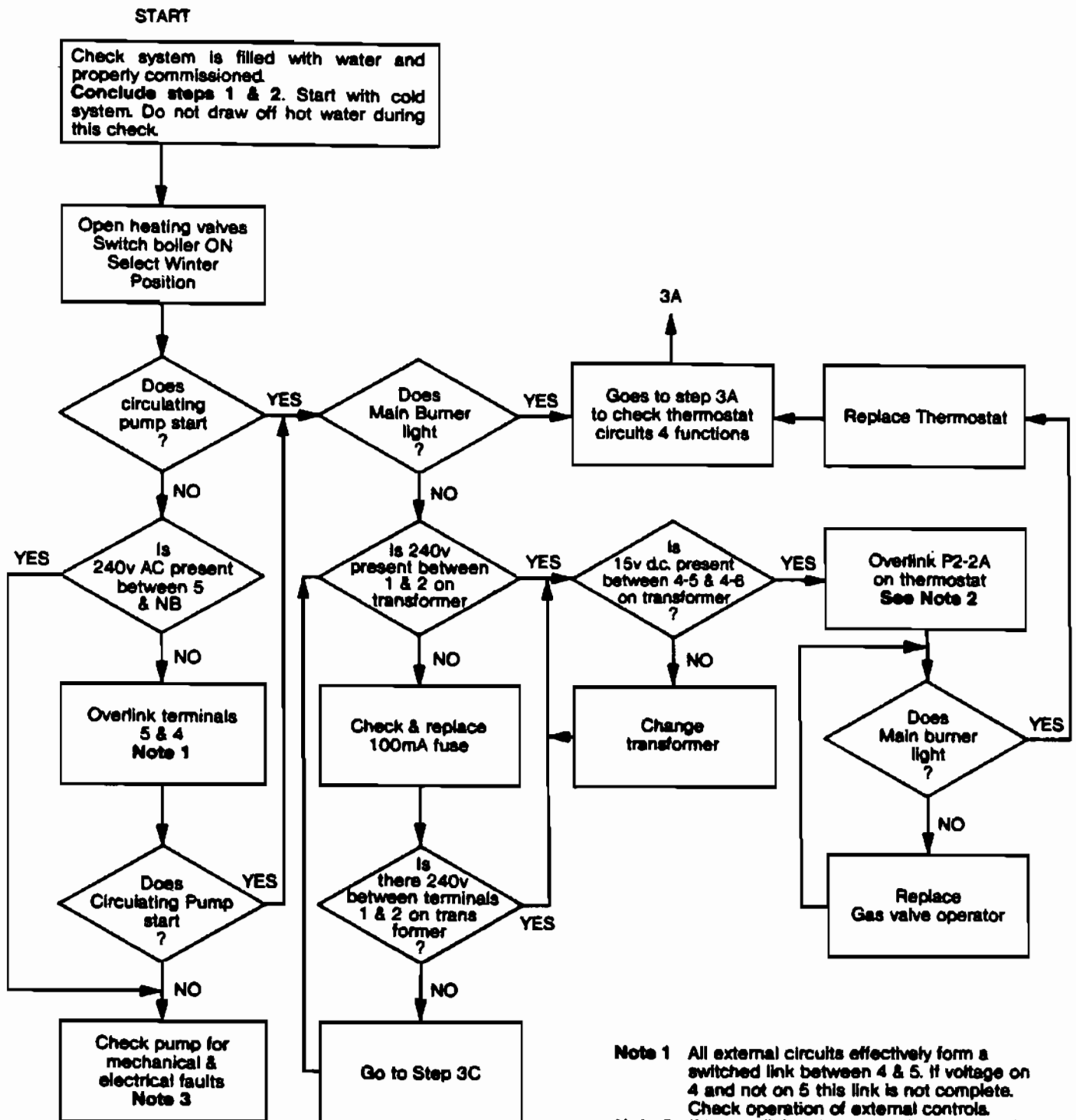

- Note 1** All external circuits effectively form a switched link between 4 & 5. If voltage on 4 and not on 5 this link is not complete. Check operation of external controls.
- Note 2** If burner lights thermostat is permanently open-circuit. Replace Thermostat. If burner does not light fault lies with gas valve operator.
- Note 3** Check supply at pump terminals, pump capacitor, rotor free. Replace pump/or pump head.

FAULT FINDING STEP 3A
CHECKING THERMOSTAT CIRCUITS

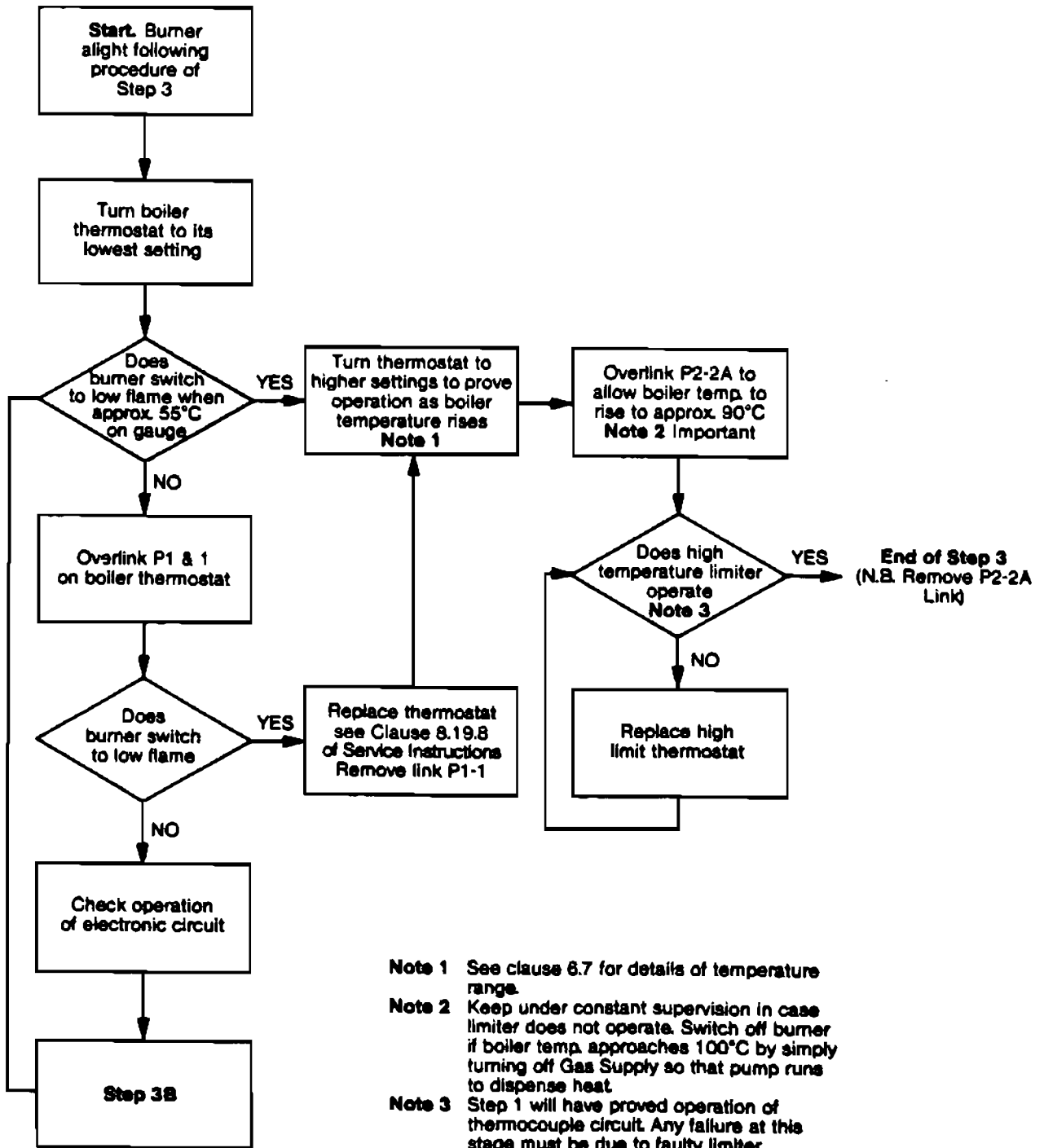

FAULT FINDING STEP 3B
CHECK OPERATION OF ELECTRONIC CIRCUIT

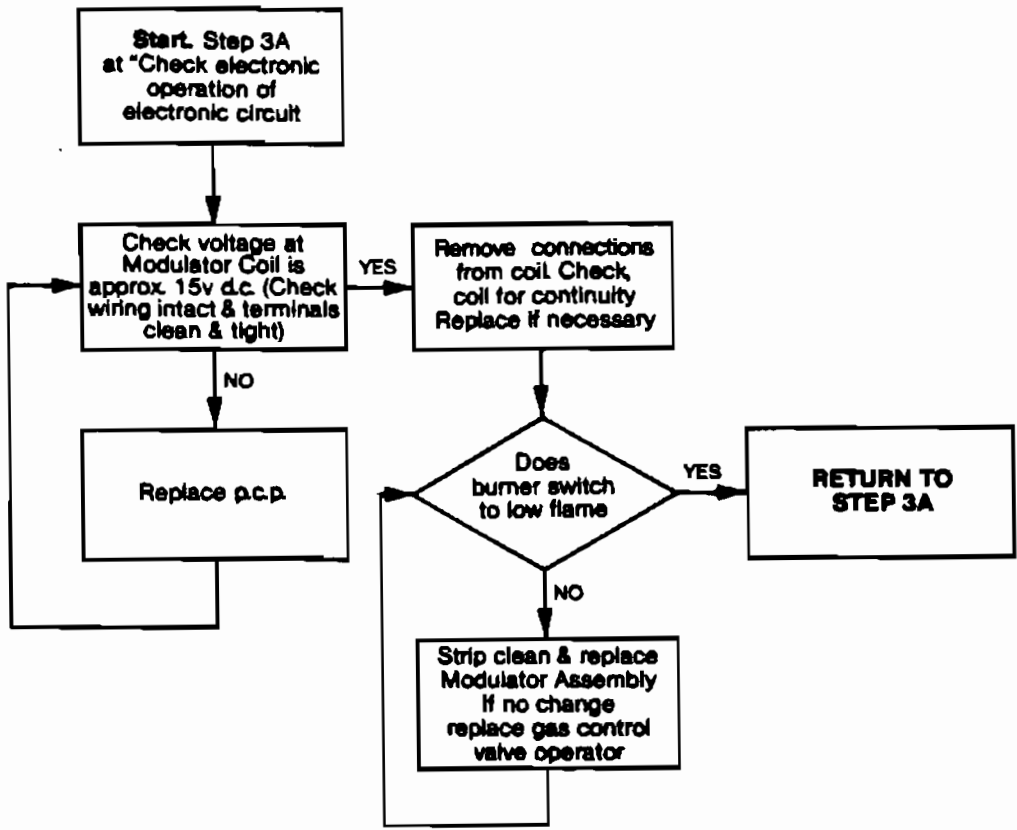

FAULT FINDING STEP 3C
CHECK HEATING MANIFOLD FLOW SWITCH (SINGLE MICROSWITCH)

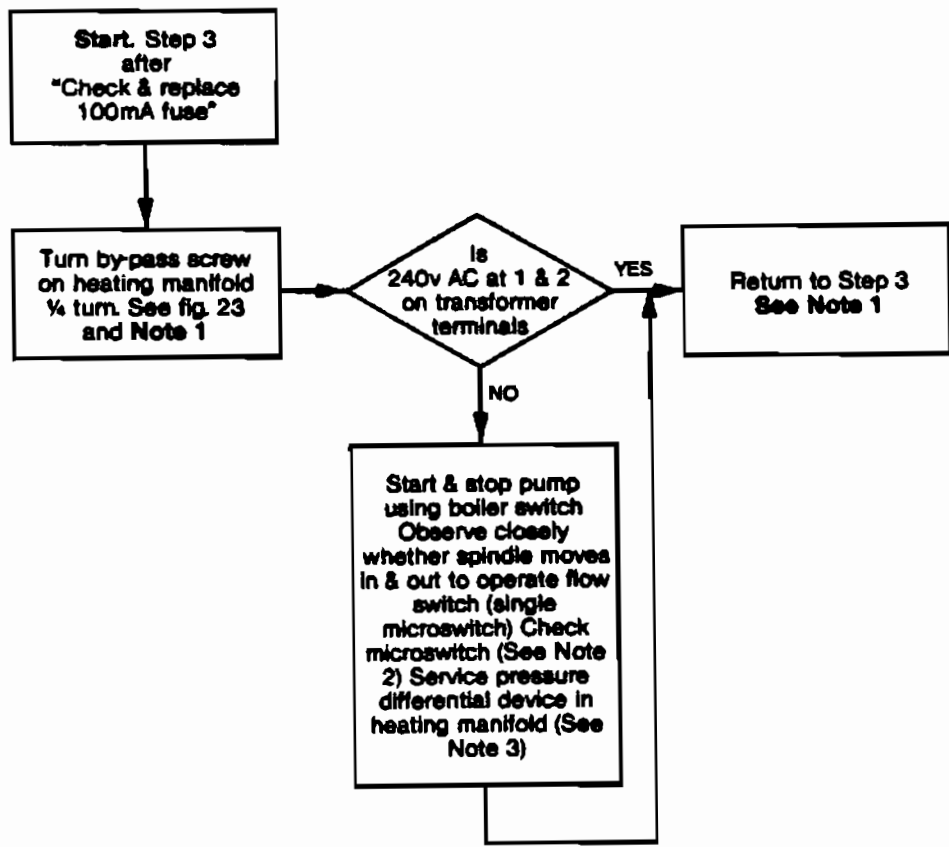

FAULT FINDING STEP 4 CHECKING DOMESTIC HOT WATER FUNCTION

Basic wiring & functions have been checked by procedures in step 3.
Open air release tap (to ensure hws heat exchanger is fully cleared of air). Light pilot, switch boiler on, select Summer position.

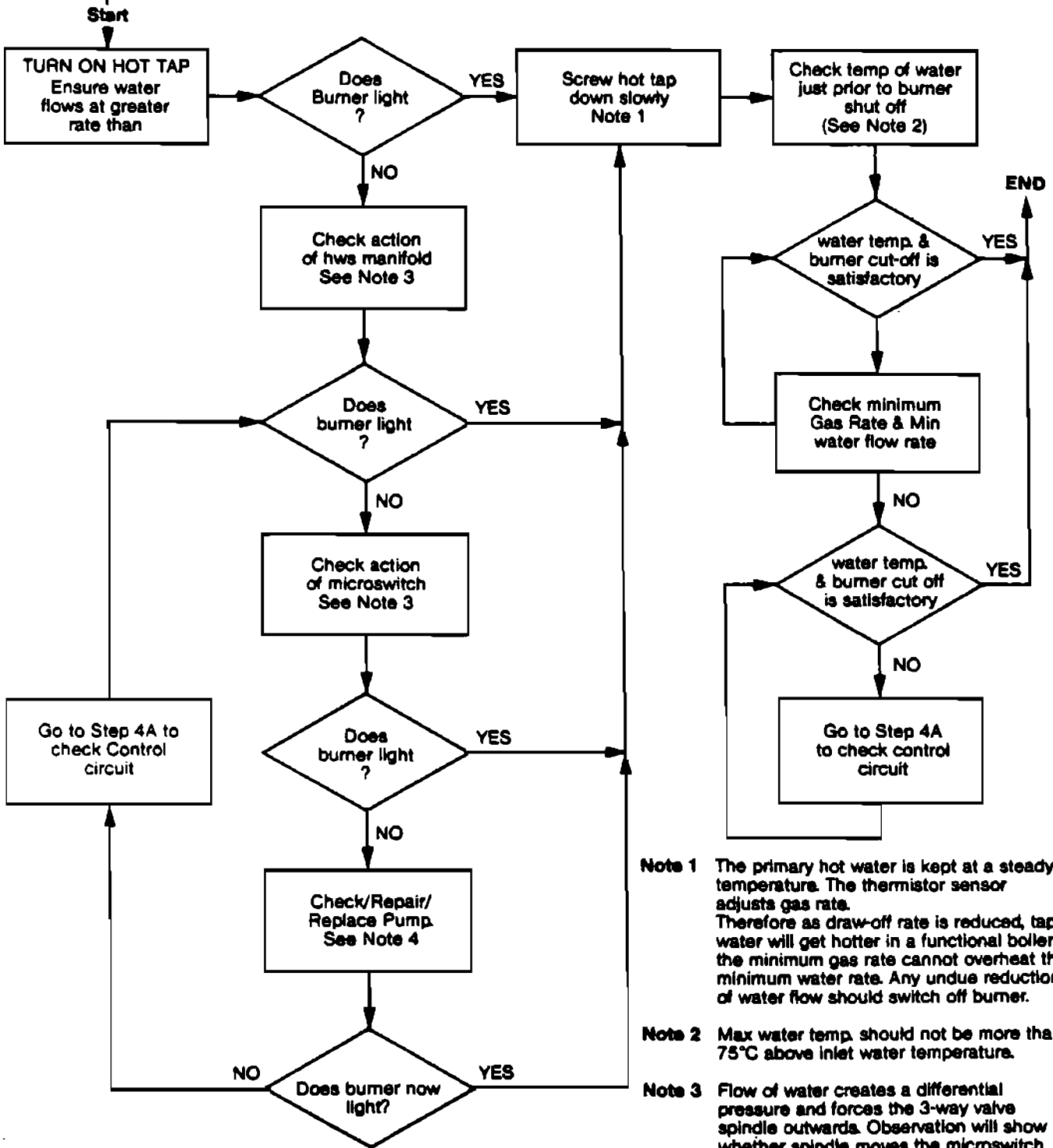

- Note 1** The primary hot water is kept at a steady temperature. The thermistor sensor adjusts gas rate. Therefore as draw-off rate is reduced, tap water will get hotter in a functional boiler, the minimum gas rate cannot overheat the minimum water rate. Any undue reduction of water flow should switch off burner.
- Note 2** Max water temp. should not be more than 75°C above inlet water temperature.
- Note 3** Flow of water creates a differential pressure and forces the 3-way valve spindle outwards. Observation will show whether spindle moves the microswitch. The microswitch itself can be checked electrically with a meter.
- Note 4** The sequence has assumed that Step 3 has been concluded (see box top left). If the pump is not faulty then double check Step 3.

FAULT FINDING STEP 4A

CHECK OPERATION OF ELECTRONIC CIRCUIT FOR HOT WATER SUPPLY MODE

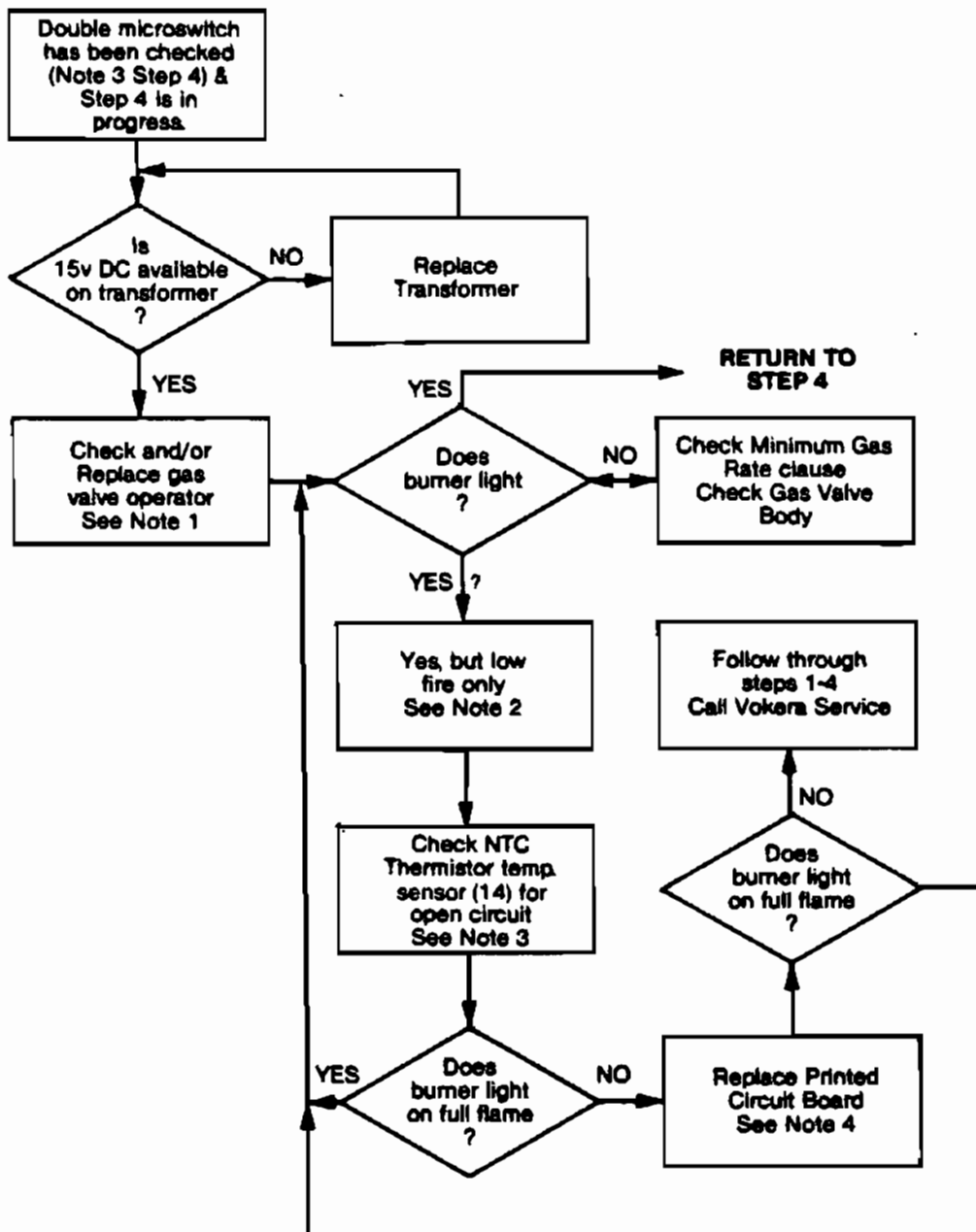

Note 1 See Service instructions Clause 8.11.3

Note 2 It is possible that if step 2 has not been followed that Max. Gas rate is very low. Check setting. Also check no restriction in gas supply.

Note 3 Fig 50 shows that increasing resistance lowers gas rate. ∴ open circuit (max. resistance) will give permanent low flame. If desired the calibration of the thermistor can be checked against the curve.

Note 4 All the previous steps have proved switches and thermostats leaving only the p.c.b. section applying to the thermistor untried.

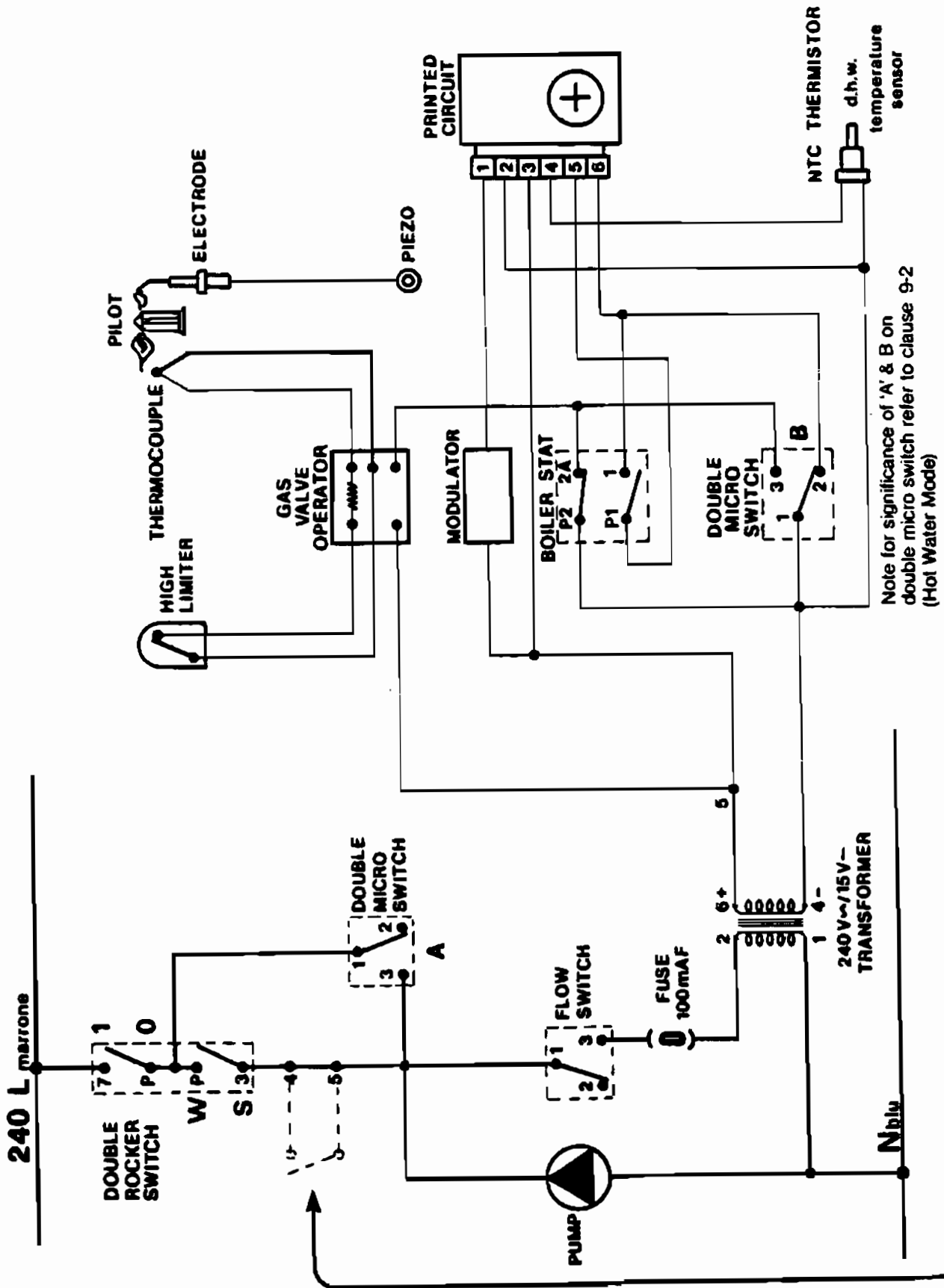

Thermostat and programmer for the central heating can be installed in place of the link between 4 and 5 on the terminal strip by removing the loop.

Fig. 53

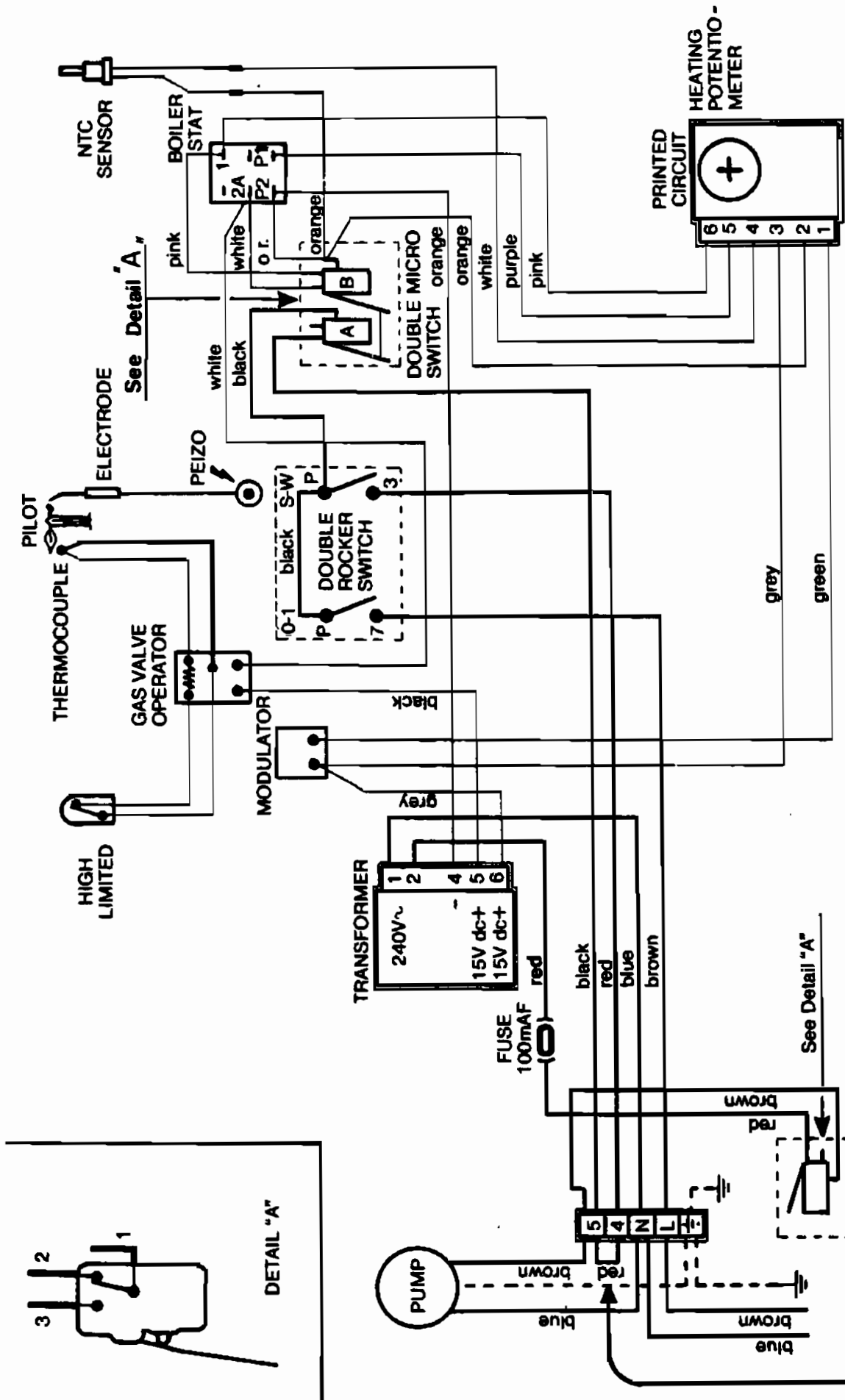

Note For significance of 'A' & 'B' on double micro-switch refer to text of clause 9-2 (Hot Water Mode)

Thermostat and programmer for the central heating can be installed in place of the link between 4 and 5 on the terminal strip by removing the loop.

Fig. 54

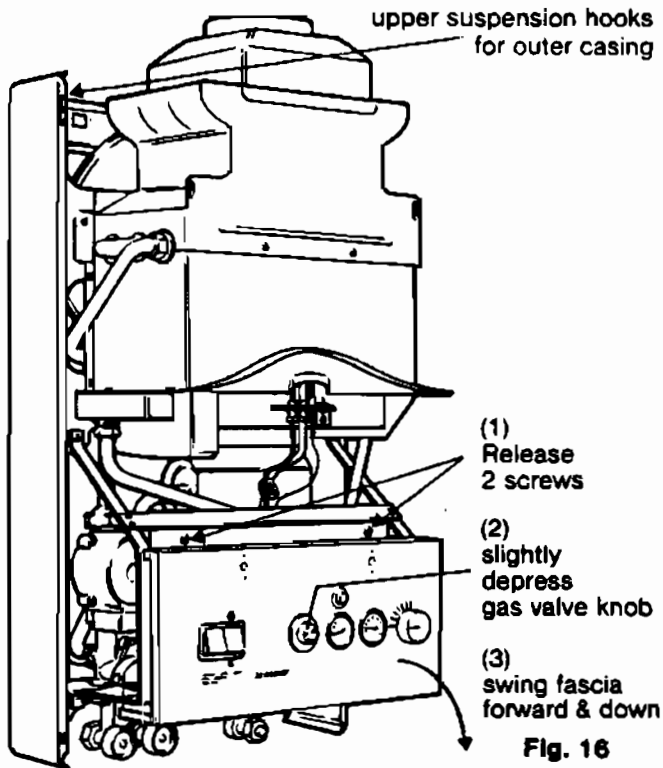

5.11 Electrical Connections

5.11.1 The electricity supply to the appliance must be as specified in section 4.7

If controls external to the appliance are used (e.g. time switch or room thermostat) design of the control circuits should be entrusted to a competent person.

N.B. It is essential that any external control circuit is wired from the same electrical isolator as that which serves the appliance. Internal wiring must not be disturbed when wiring external controls to the appliance.

5.11.2 To gain access to the terminal block, release the 2 screws securing the outer front controls fascia. (see figs 16 & 17). The panel is hinged at the bottom swing it outwards and downwards. Slightly depress the gas control knob to prevent it from fouling the edge of the aperture.

The terminal block is positioned at the bottom left hand corner.

5.11.3 The cable between the isolator and the appliance terminal block must be 3-core of size 0.75mm² (24 x 0.2mm).

5.11.4 Pass the cable through the cord anchorage located on the left hand underside of the controls fascia, and connect the cables so that the length of the individual conductors is such that should the cable slip the anchorage the current carrying conductor becomes taut before the earthing conductor (refer to fig 17)

5.11.5 Securely tighten all terminal screws. Arrange the cable and so that a small amount of slack occurs between the cord anchorage and the terminal block, and tighten the cord anchorage gland nut.

5.11.6 The cable exterior to the appliance should be neatly arranged so that during subsequent operations requiring access the controls fascia may be opened and closed easily without straining the cable.

5.11.7 Close up controls fascia.

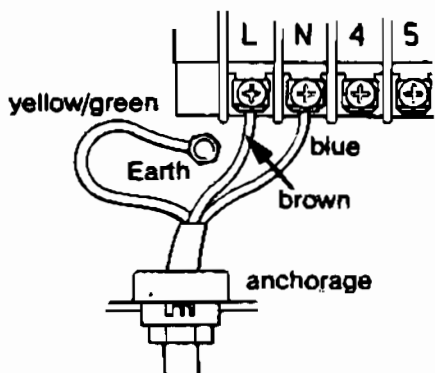
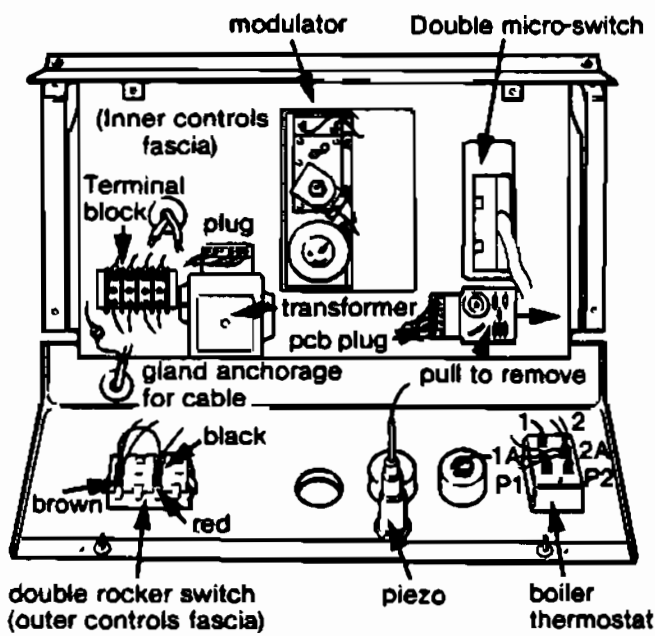

4.7 Electrical Supply

The boiler is supplied for operation on 240/250 50Hz electricity supply. It should be protected with a 3-amp fuse.

THIS APPLIANCE MUST BE EARTHED.

The method of connection to the mains electricity supply must allow complete isolation from the supply. The preferred method is by using an unswitched shuttered socket-outlet together with a fused 3-pin plug both complying with BS 1363.

Alternatively a fused double pole switch having a contact separation of at least 3mm serving only the boiler must be used.

Recommended wiring for Time Clocks

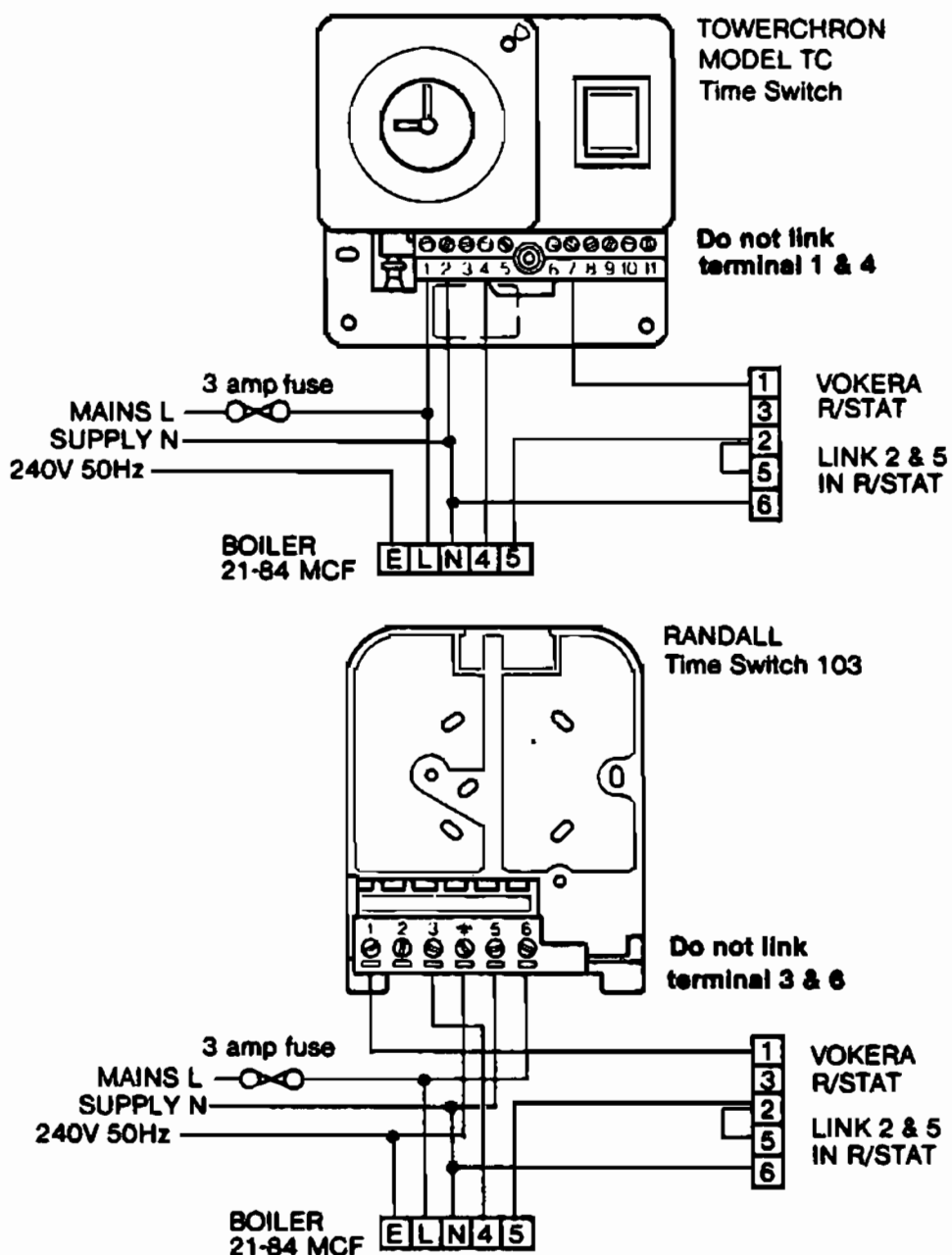

Typical Resistance v.
Temperature Characteristics

Code	T(°)	Lead Colour
Y-080T8	80	White-white

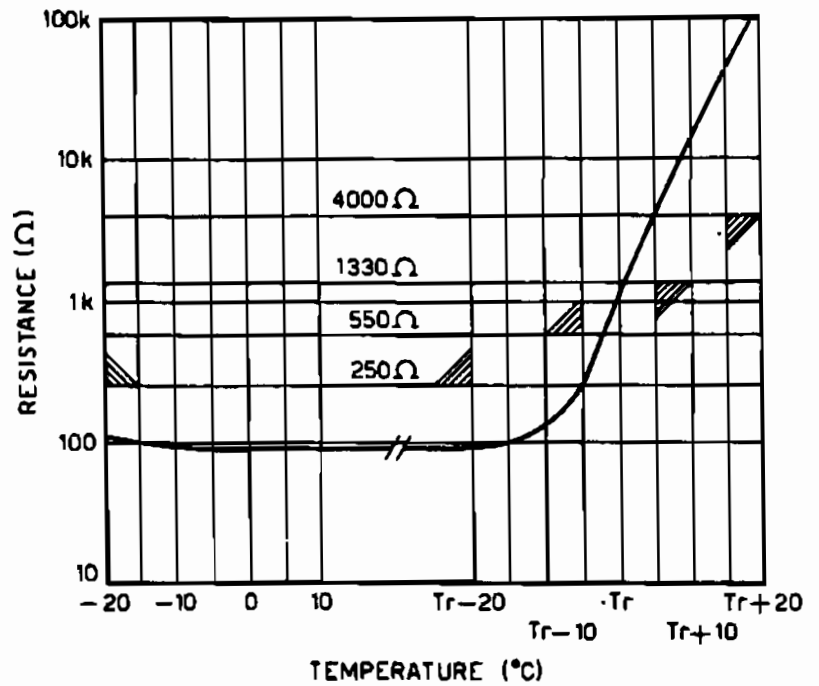

Fig. 50 Characteristics of the dhw temperature sensor

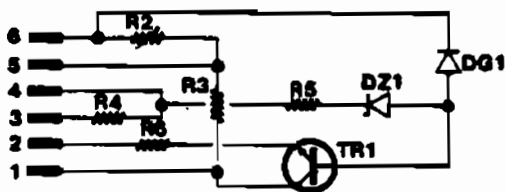

Fig. 51 Schematic of the p.c.b. circuit

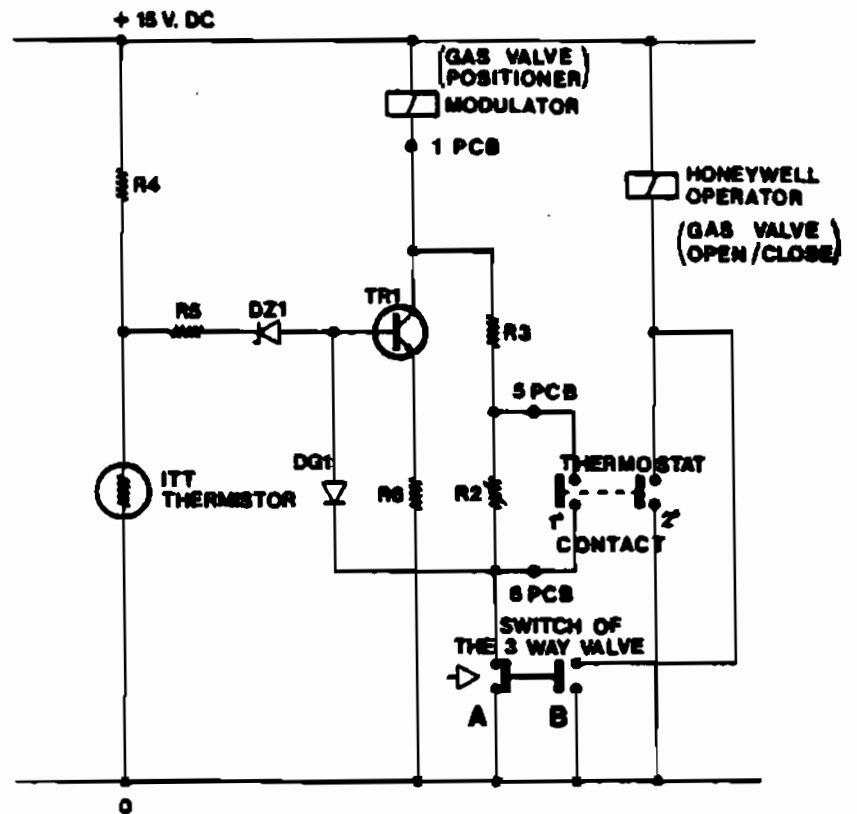

Fig. 52 Schematic of the electronic circuit

N.B. figs 50-52 given for elucidation
of text of clause 9.4
For normal trouble fault finding and servicing
procedures refer only to Figs 53-55.

SECTION 8 SERVICE INSTRUCTIONS

8.1 General

To ensure sufficient safe operation of the appliance it is necessary to carry out routine servicing at regular intervals.

The frequency of servicing will depend upon the particular installation conditions and the use to which the boiler is put; but, in general, once per year should be adequate.

The following instructions apply to the boiler and its controls, but it should be remembered that the central heating and domestic hot water systems will also require attention from time to time.

8.2 Important Notes

WARNING: Before starting any servicing work, switch OFF the mains electricity supply and disconnect the plug at the main isolating switch and socket. (If a switch is used, remove the fuse).

Turn 'OFF' gas supply at the gas service tap fitted to the appliance.

Always test for gas soundness after any service work and after exchanging any gas carrying component.

Always after any service work and after exchanging any electrical component, follow the instructions in the British Gas Multi Meter Book for preliminary electrical system checks, particularly the checks -

- A Earth continuity
- C Polarity, and
- D Resistance to earth

8.3 Recommended routine Servicing

8.3.1 Annual Service

The following procedures should be carried out at least once per year

1. Inspect exterior for signs of damage and deterioration particularly of flue pipework and electrical connections.
2. Inspect air supply and ventilation arrangements comparing them with the requirements laid down in clauses 4.5.1-4.5.2 to ensure no alterations have been made since installation.
3. Turn off mains electricity and remove front casing (see clauses 8.4.1-8.4.3)
4. Turn on electricity and operate the boiler for a few minutes on hot water to permit a preliminary inspection of its operation.
5. Ensure central heating valves (fig 1) are open. Note these are ½ turn valves which indicate red when open blue when closed.

Observe pressure gauge reading (fig 1) which should be approximately 10m w.g. when the system is cold (see clause 6.3.4)
6. Turn off mains electricity and turn off gas service tap on the appliance.
7. Gain general access as described below.
8. Remove pilot burner assembly and brush clean. Inspect pilot injector and blow clean.

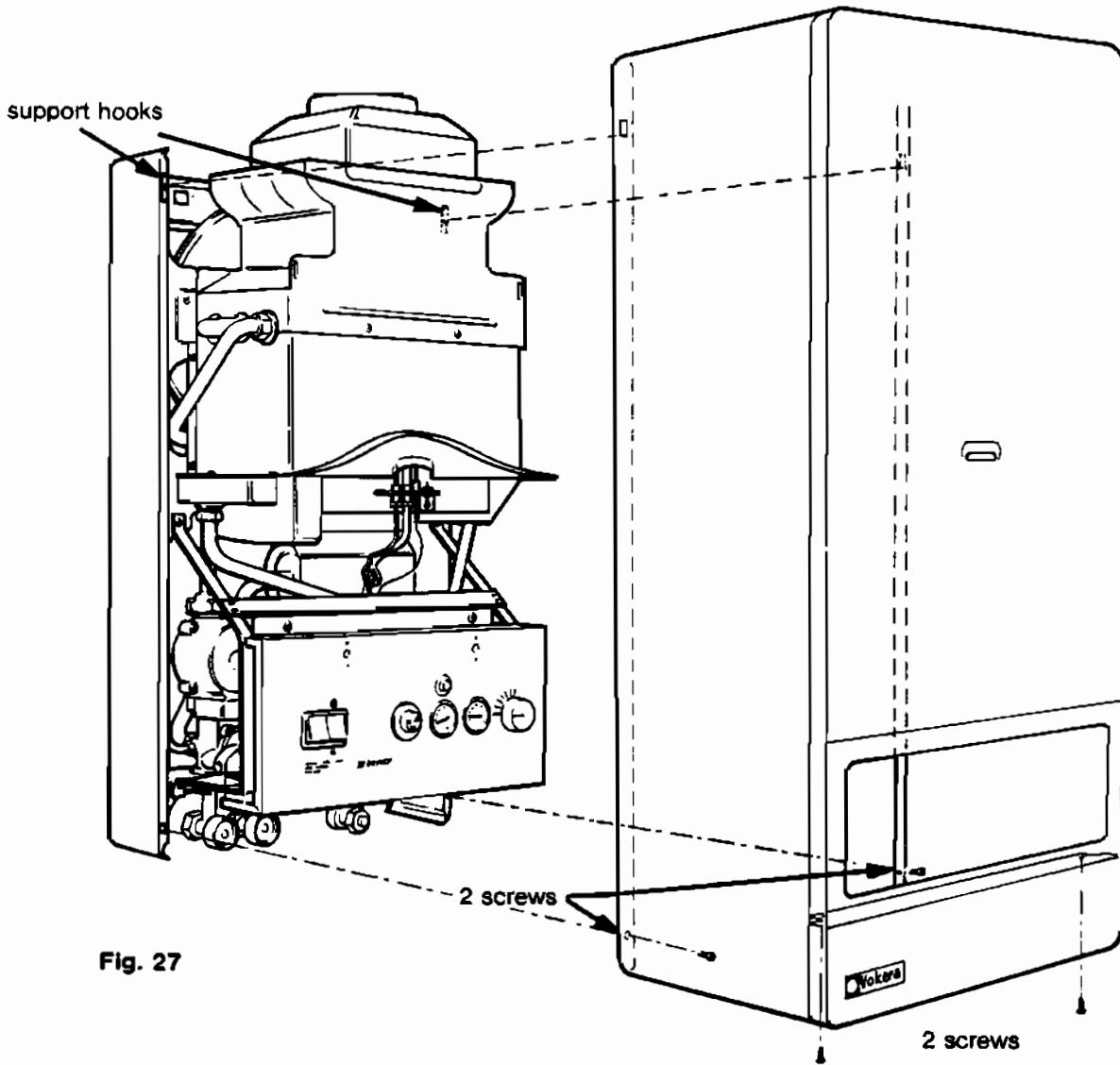

Fig. 27

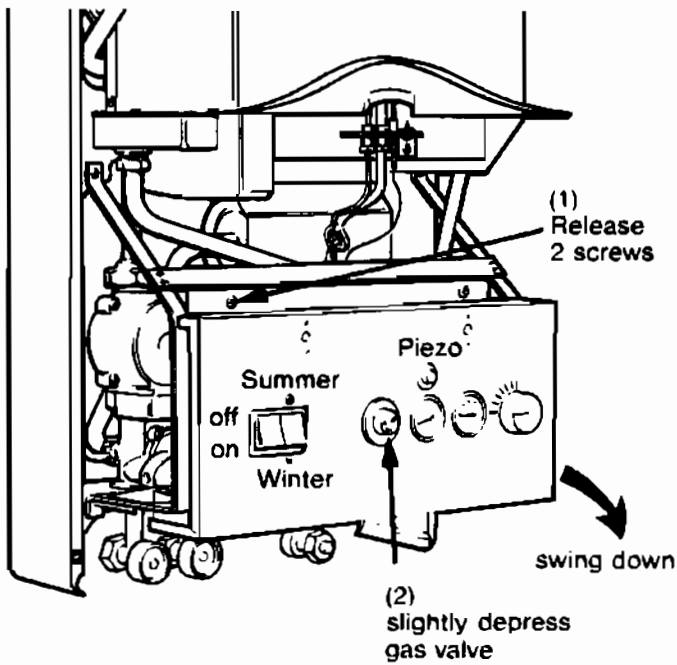

Fig. 28

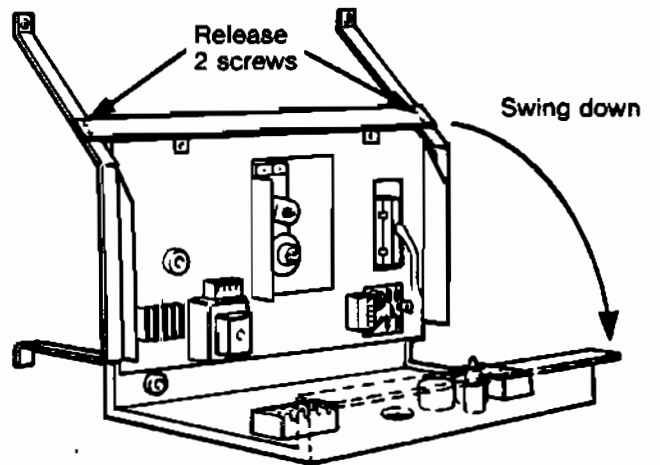

Fig. 29

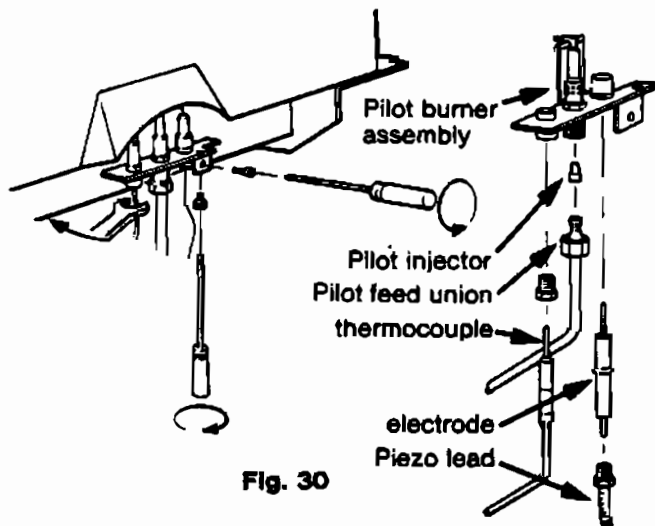

Fig. 30

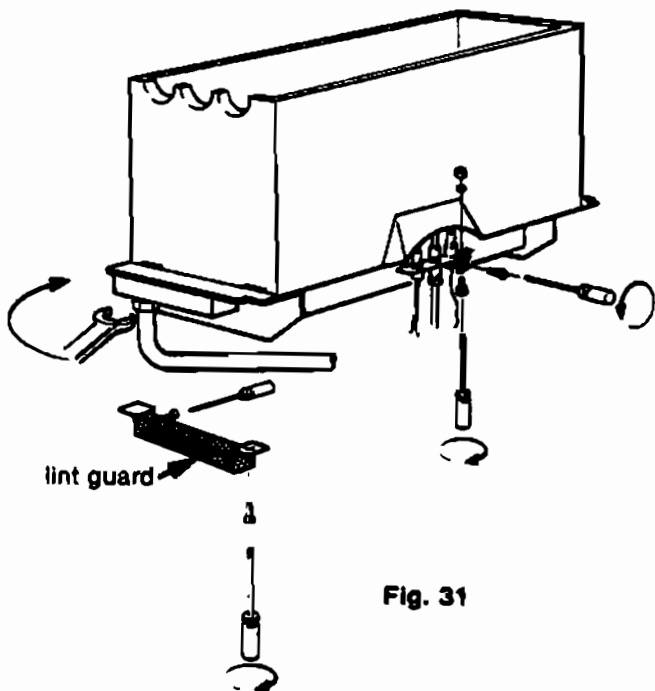

Fig. 31

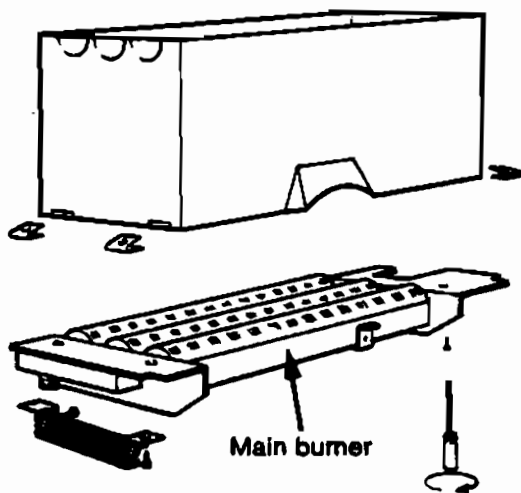

Fig. 32

8.5 To remove/replace pilot burner, thermo-couple and electrode
Refer to fig no. 30
For part no reference see fig 49

8.5.1 Gain general access as (8.4)

8.5.2 Electrode (part no. 4632)

8.5.2.1 Pull lead off terminal

8.5.2.2 Unscrew retaining nut and remove electrode

8.5.2.3 Replace in reverse order.

8.5.3 Thermocouple (Part No. 3771)

8.5.3.1 Disconnect lead at gas valve end. Unscrew locknut and remove.

8.5.3.2 Replace in reverse order.

8.5.4 Pilot Burner (Part No 4886)

8.5.4.1 Remove electrode and thermocouple connections and leads.

8.5.4.2 Disconnect pilot supply pipe at both ends and remove.

8.5.4.3 Release 2 screws securing bracket to burner frame and remove the one piece burner/Bracket assembly.

8.6 To remove Main Burner
Part No. 4630 Fig 49
Refer to figs 31 & 32

8.6.1 Gain general access (8.4)

8.6.2 Remove pilot burner assembly (8.5)

8.6.3 Release 2 screws and remove lint guard.

8.6.4 Undo the gas burner union.

8.6.5 Support the main burner and remove the 4 retaining screws. Ease the burner from the base of the combustion chamber.

8.6.6 Reassemble in reverse order.

8.7 To remove injectors
Part no 4668 fig no. 49

8.7.1 Follow instructions 8.6.1 - 8.6.5

8.7.2 Unscrew injectors from inner face of burner manifold.

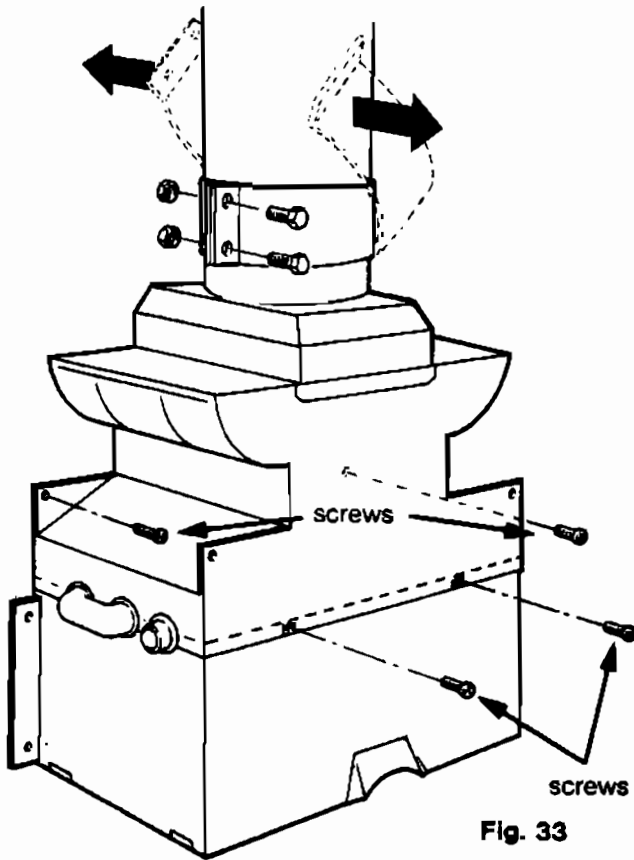

Fig. 33

8.8 To remove flue hood

Part No. 4343 Fig 49

Refer to figs 33 & 34

- 8.8.1 Gain general access (8.4)
- 8.8.2 Remove split collar from flue connection
- 8.8.3 Release 4 screws (2 on face, 2 on back frame) and ease flue hood up.
- 8.8.4 Reassemble in reverse order.

8.9 To remove main heat exchanger

Part no. 4333 Fig 49

Refer to fig 34

- 8.9.1 Remove flue hood (8.8)
- 8.9.2 Close heating flow and return valves (fig 1) N.B. valve heads indicate blue when closed.
- 8.9.3 Drain appliance by turning safety valve knob ¼ turn to use as drain tap.
- 8.9.4 Disconnect unions at each end of heat exchanger and gently ease upwards to remove from combustion chamber.
- 8.9.5 Reassemble in reverse order.

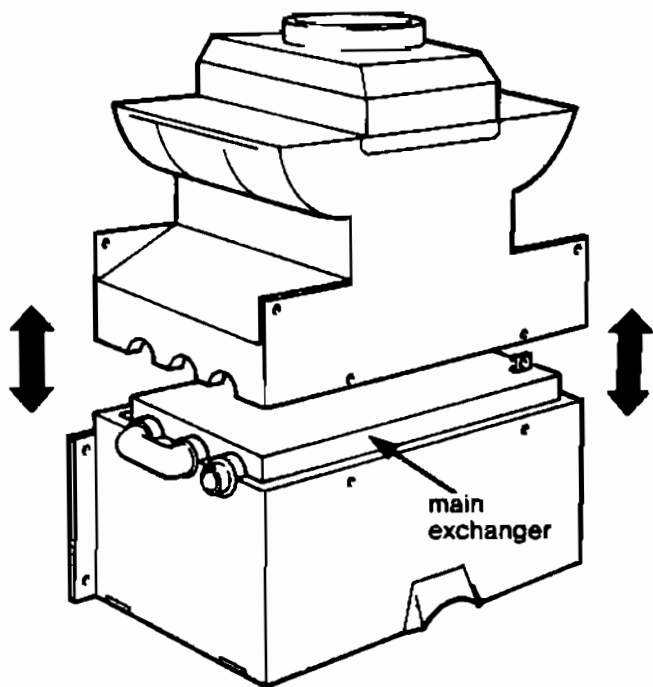

Fig. 34

8.10 To remove Combustion Chamber Insulation Panels

Part no. 0377 Fig 49

Refer to fig 35

- 8.10.1 Remove main heat exchanger (8.9)
- 8.10.3 Gently prise panels inwards in order shown and lift out
- 8.10.3 Reassemble (N.B. very brittle) in reverse order.

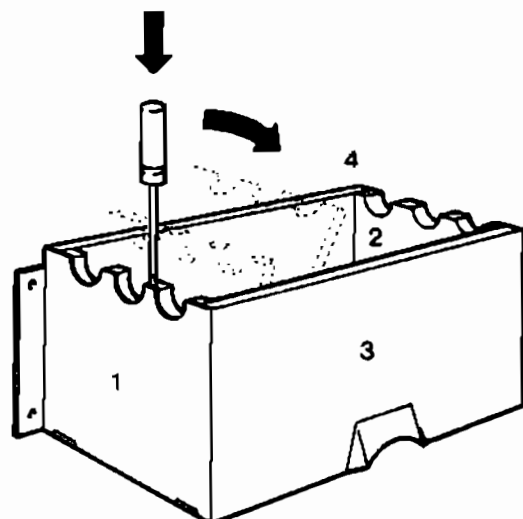

Fig. 35

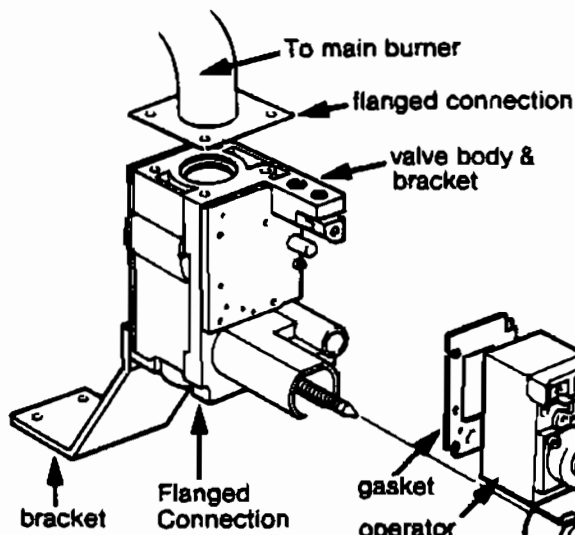
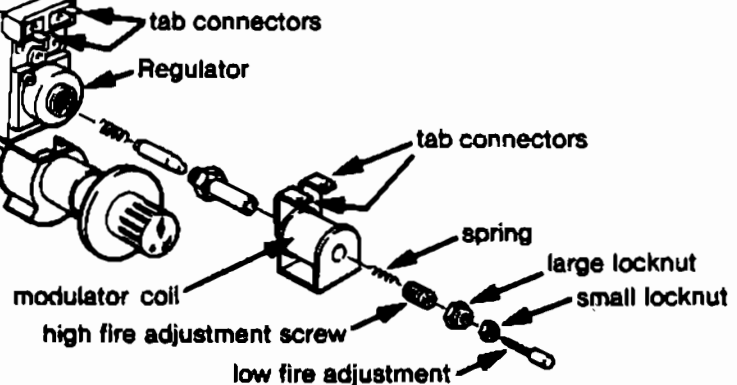

Fig. 36

8.11.4.2 Disconnect leads from high limit thermostat, and disconnect thermocouple and pilot supply pipe connections.

8.11.4.3 Remove screws securing bracket to base frame

8.11.4.4 Remove 4 flange securing screws at each end, and withdraw valve (This may be easier with gas pipe disconnected from main burner)



8.11 To remove/replace Gas Control Valve Modulator Coil and Operator

Refer to fig 36

For part no reference see fig 49

8.11.1 Gain general access (8.4)

8.11.2 Modulator Coil (part no. 4096)

8.11.2.1 Pull off electrical leads from tab connectors.

8.11.2.2 Slacken large locknut, unscrew high fire adjustment screw and remove (N.B. take care of spring)

8.11.2.3 Remove modulator coil.

8.11.2.4 Replace in reverse order (see fig 55 for electrical connections)

8.11.2.5 Check burner pressures (6.6.8)

8.11.3 Operator (part no 0401)

8.11.3.1 Pull off all electrical leads from modulator and operator tab connectors.

8.11.3.2 Remove modulator coil.

8.11.3.3 Release 4 screws securing operator to gas valve body (2 at top below tab connectors 2 at bottom extreme corners).

8.11.3.4 Remove operator, exposing gasket.

8.11.3.5 Replace in reverse order using new gasket (see fig 55 for electrical connections)

8.11.3.6 Check burner pressures (6.6.8)

8.11.4 Gas Control Valve

8.11.4.1 Remove modulator coil and operator as detailed above

8.11.4.5 Replace in reverse order using new gasket

8.11.4.6 Test all disturbed joints for gas soundness. Check burner pressures (6.6.8)

8.11.4.7 (see fig 36)

If burner pressures are not correct proceed as follows:

High Flame

- Loosen small locknut and completely remove low flame adjustment screw

- Turn on mains electricity

- Turn on dhw draw-off full bore to establish main flame

- Loosen large locknut and turn main burner adjustment screw (clockwise to increase pressure, anti-clockwise to decrease) until correct pressure (13.3mbar/5.3in wg) is observed. Carefully tighten locknut observing pressure is not altered.

Low Flame

Replace low flame adjusting screw.

Remove wire from terminal No.1 on heating stat and replace on 1A

Turn on electrical supply.

Turn on boiler for Heating.

Boiler will light up in modulation adjust pressure using fine adjusting screw turn clockwise to increase anti clockwise to decrease (3.3mbar/1.3in wg)

Turn off Electrical Supply.

Remove wire on terminal No. 1A on heating stat and replace on No.1.

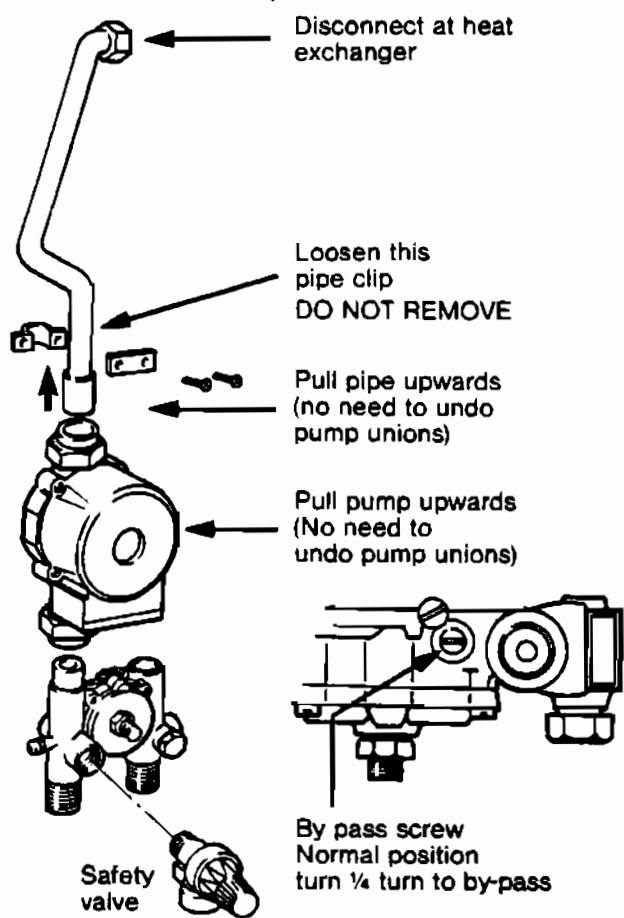

Fig. 37

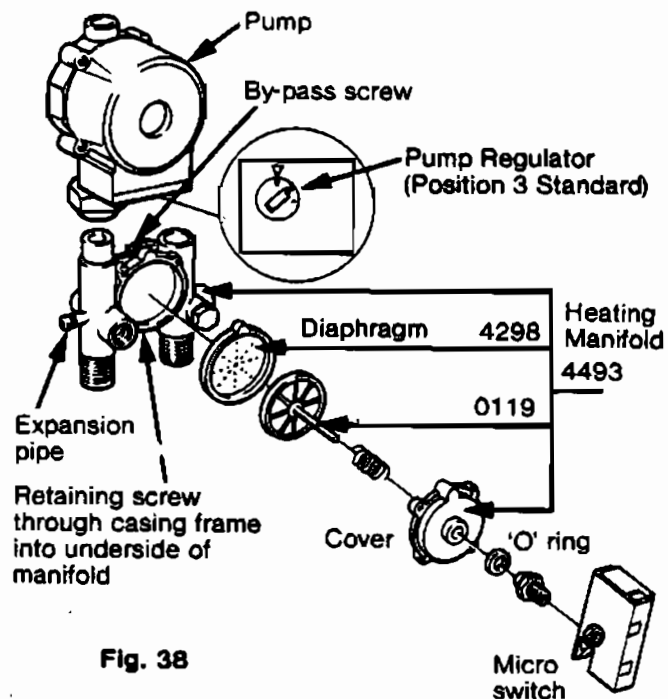

Fig. 38

8.12 To remove pump
Part no 6120 fig 49
Refer to fig 37

- 8.12.1 Gain general access (8.4)
- 8.12.2 Close heating flow and return valves (fig 1 (20 & 21)
(N.B. valve windows indicate blue when closed - ½ turn operation).
- 8.12.3 Drain appliance via safety valve by ¼ turn of safety valve knob
- 8.12.4 Disconnect pump electric leads from push-on connectors at boiler terminal block and earth lead from tab on rear of control fascia.
- 8.12.5 Loosen outlet pipe clip, disconnect pipe union connection at heat exchanger and pull pipe upwards with a slight twisting movement to remove from pump.
- 8.12.6 Grasp pump and pull upwards with a slight twisting movement to disconnect at inlet.
- 8.12.7 Reassemble in reverse order. Refer to fig 55 for wiring connections.

8.13 To remove heating manifold
Part No. 4493 fig 49
Refer to fig no 38

- 8.13.1 Remove pump (8.14)
- 8.13.2 Disconnect safety valve discharge, and heating valve unions.
- 8.13.3 Remove retaining screw (securing manifold to frame)
- 8.13.4 Disconnect unions including expansion pipe.
- 8.13.5 Unscrew and remove retaining nut and remove micro switch
- 8.13.6 Remove manifold

Manifold Assembly

Release cover retaining screws and ease off with a screwdriver.
Refer to figs 38 and 49 for location of components.

8.14 Removal of domestic hot water heat exchanger
Part no 4687 Fig 49
Refer to fig 39

- 8.14.1 It is advisable to have a receptacle or some absorbent material beneath the appliance to catch surplus water.

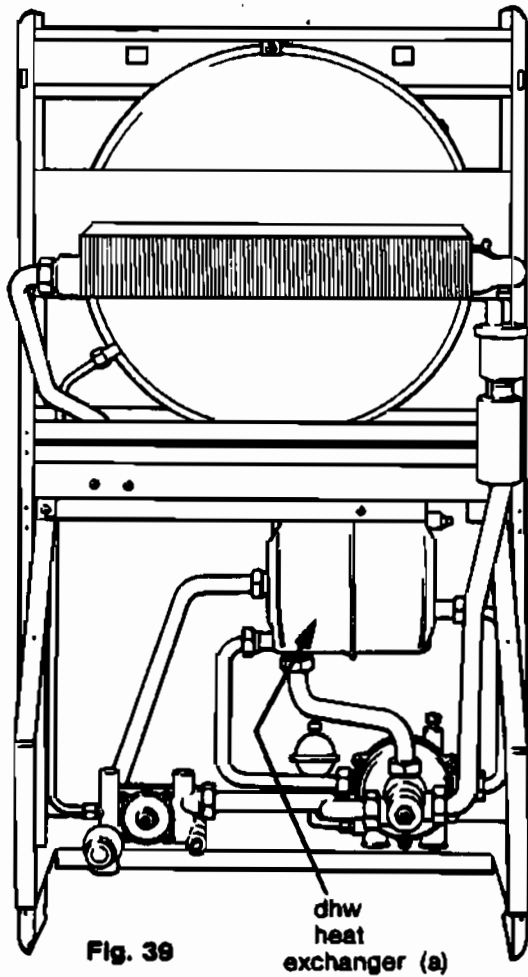

Fig. 39

dhw heat exchanger (a)

- 8.14.2 Gain access (8.4)
- 8.14.3 Close cold stop cock and heating valves.
- 8.14.4 Open draw-off (or drain tap on dhw system) to drain secondary side open air bleed valve on exchanger.
- 8.14.5 Drain primary side via safety valve by ¼ turn of knob.
- 8.14.6 Undo 4 union connections and withdraw component
- 8.14.7 Reassemble in reverse order.

8.15 Removal of 3-way diverting valve
Part no. 4495 fig 49
Refer to fig no 40 a & b

- 8.15.1 Gain access (8.4)
- 8.15.2 Close central heating valves (valve head indicates blue when closed)
- 8.15.3 Drain appliance via safety valve by ¼ turn of knob.
- 8.15.4 Unscrew retaining nut and remove micro switch
- 8.15.5 Disconnect 3 pipe unions and thermistor connection on underside.
- 8.15.6 Slacken retaining grub screws securing valve to manifold and withdraw valve. (if necessary slacken unions at opposite ends of connecting pipes to facilitate removal).
- 8.15.7 Reassemble in reverse order.

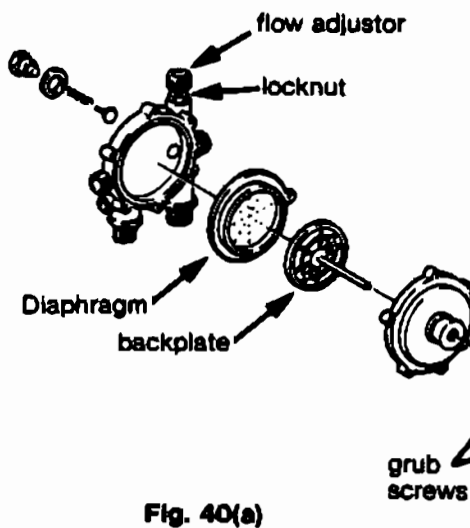

Fig. 40(a)

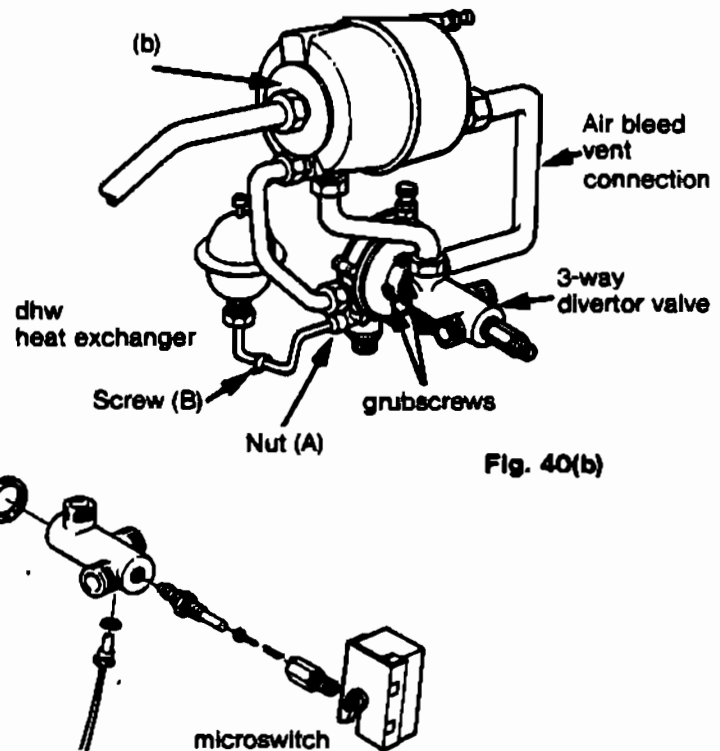

Fig. 40(b)

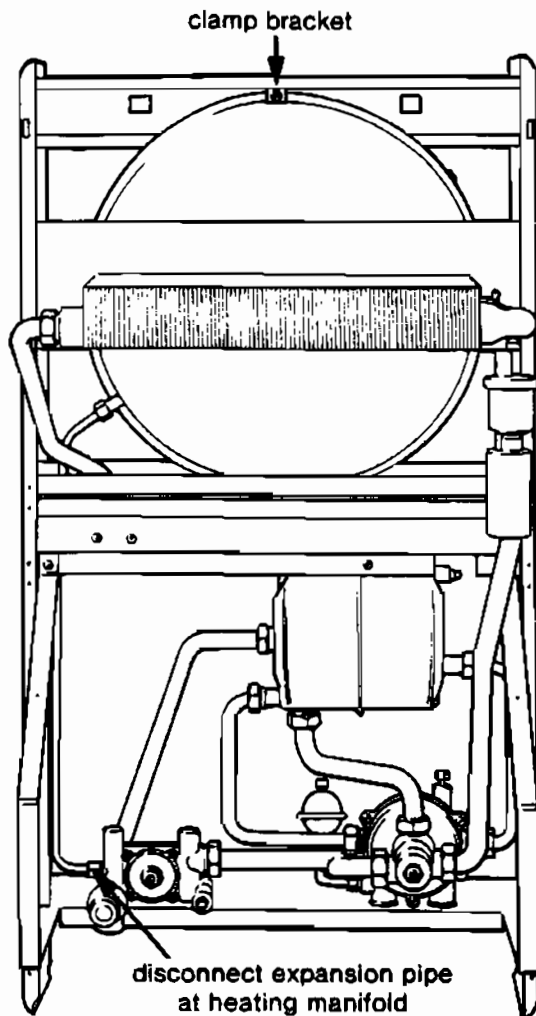

Fig. 41

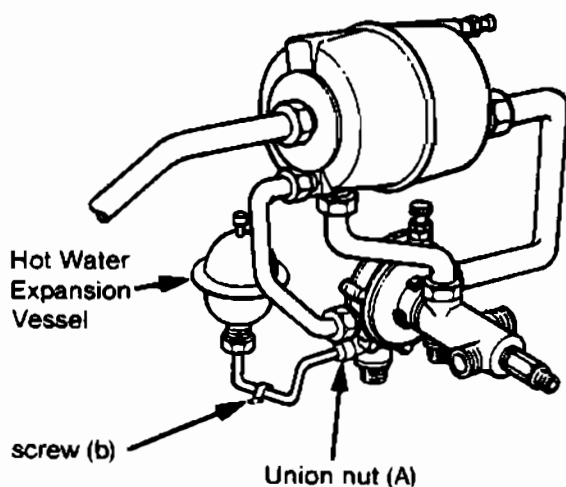

Fig. 42

8.16 Removal of Domestic Hot Water Manifold

*Part No 4494 fig 49
Refer to fig 40 a & b*

- 8.16.1 Remove 3 way diverting valve (8.15)
- 8.16.2 Close cold water inlet stopcock and drain secondary side by opening draw-off or drain tap.
- 8.16.3 Remove dhw heat exchanger (8.14)
- 8.16.4 Slacken screw B (fig 40b) and disengage bracket from expansion pipe.
Undo union nut A (fig 40b) and remove expansion vessel.
- 8.16.5 Disconnect unions at cold water inlet and hot water outlet and remove manifold retaining screw (through base frame)
Remove manifold. Fig 40a gives details of further disassembly.
- 8.16.6 Reassemble in reverse order.

8.17 Removal of heating expansion vessel

*Part no 4492 Fig 49
Refer to fig 41*

- 8.17.1 Gain access (8.4)
- 8.17.2 Close central heating valves (½ turn till blue indicator on valve head)
- 8.17.3 Drain appliance via safety valve by ¼ turn of knob.
- 8.17.4 Remove top clamp bracket and unscrew union at lower end of connecting pipe.
Lift vessel and pipe together.
- 8.17.5 Remove pipe from vessel and transfer to new vessel.
- 8.17.6 Re-assemble in reverse order.

8.18 Removal of DHW Expansion Vessel

*Part No. 4916 Fig 49
Refer to fig 42*

- 8.18.1 Gain access (8.4)
- 8.18.2 Close cold water inlet stop cock and drain off via hot water draw-off or drain tap.
- 8.18.3 Slacken screw (b) (fig 42) and disengage bracket from pipe (do not remove screw or bracket).
- 8.18.4 Slacken union (a) and release.
- 8.18.5 Remove vessel and connecting pipe.

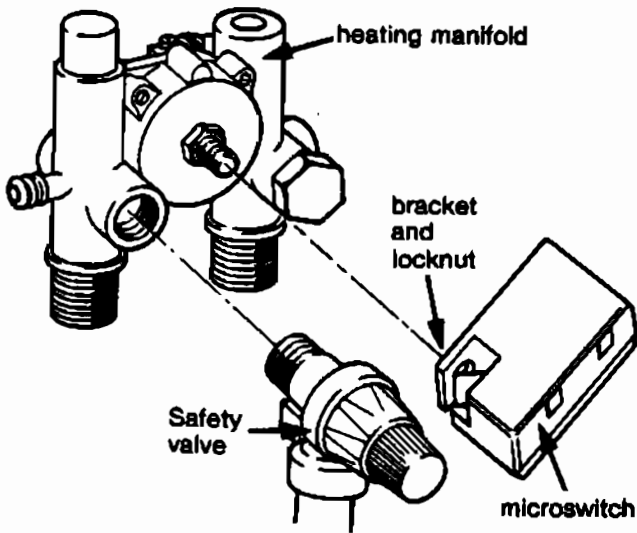

Fig. 43

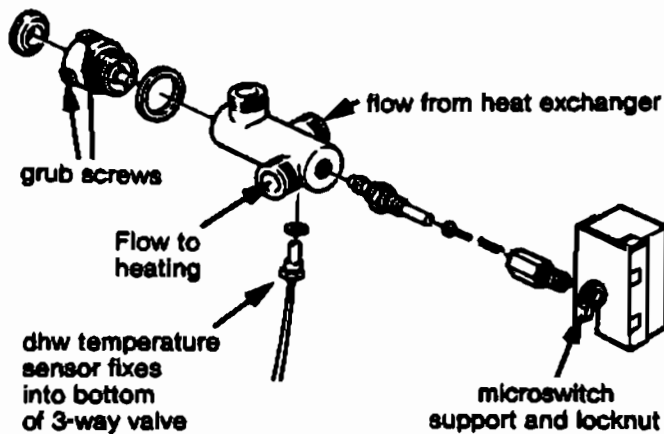

Fig. 44

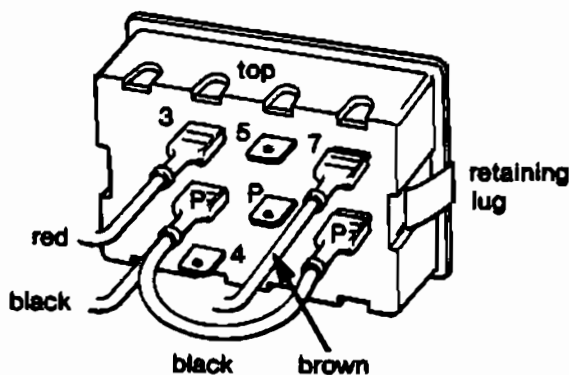

Fig. 45

8.19 Removal of Electrical Components

8.19.1 Ensure electricity is switched off at main isolator and gain general access (8.4)

8.19.2 Heating micro switch

Part no 4302 fig 49

Refer to fig 43

Hold switch and unscrew retaining nut

Remove switch and remove cover

Pull off electrical tab connections

Reassemble in reverse order, reconnecting electrical tab connectors following figure 55

8.19.3 DHW Microswitch

Part no 4563 fig no. 49

Refer to fig no 44

Hold switch and remove locking nut securing it to the 3 way valve

Remove switch and remove cover.

Pull off electrical tab connections.

Reassemble in reverse order reconnecting electrical tab connectors following figure 55.

8.19.4 DHW Temperature sensor (NTC Thermistor)

Part no. 4559 Fig No. 49

Disconnect flying leads by pulling in-line connectors apart.

Close heating valves by turning 1/2 turn till blue indicator appears on handles. Open safety valve by 1/4 turn of knob to drain boiler.

Unscrew thermistor probe from base of 3-way valve (fig 44)

Reassemble in reverse order.

8.19.5 High Limit Thermostat (Thermocouple Interruptor)

Part No. 4978 Fig. No. 49

Disconnect 2 electrical connections at Gas Control Valve

Remove split pin from carrier tube and withdraw sensor probe. Reassemble in reverse order.

8.19.6 Double Rocker Switch

Part No. 4359 Fig.

Refer to figs 45 & 46

Pull off electrical tab connectors. Squeeze spring retaining lugs and press switch out of aperture in the controls fascia.

To re-assemble press switch into aperture until clips engage and refer to fig 45 to ensure correct location of switch and wiring connections.

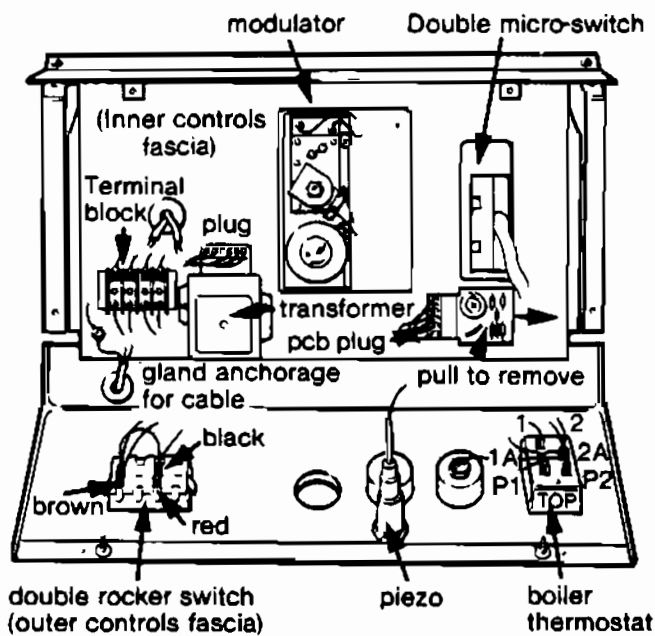

Fig. 46

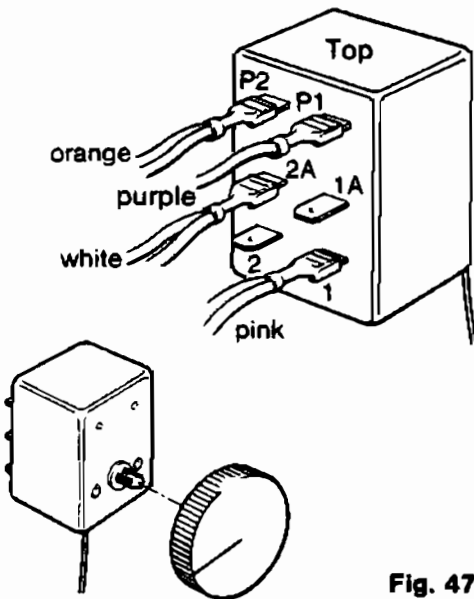

Fig. 47

8.19.7 Transformer

Part no. 4566 Fig 49

Refer to fig 46

Pull white plastic plug from top of transformer

Remove 2 securing screws and lift out.

Reassemble in reverse order.

8.19.8 Boiler Thermostat

Part no. 4542 Fig 49

Refer to fig 46 & 47

Remove split pin and pull sensing probe from carrier tube

Pull electrical tabs off back of thermostat.

Pull knob off front revealing 2 retaining screws.

Remove screws to release thermostat and remove.

Reassemble in reverse order.

Refer to fig 47 to ensure correct location of thermostat and push-on wiring tabs.

Refer to electrical drawing fig. 55

8.19.9 Printed Circuit Board

Part No. 4072 Fig 49

Refer to fig 46

Grip p.c.b. and pull firmly to right to release.

Refit in reverse order. If new, reset burner pressures in accordance with clause 6.6.8.9. For required setting refer to data badge.

8.19.10 Piezo Unit

Part No. 4537 Fig No. 49

Refer to fig 46

Pull off electrical connection

Remove locknut on back of fascia and remove piezo unit.

Re-assemble in reverse order.

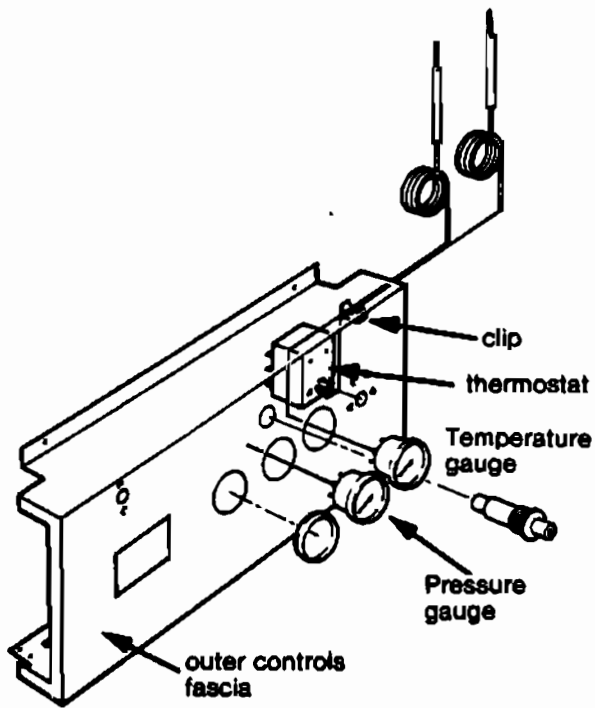

Fig. 48

8.20 Removal of Mechanical Instruments and Components

8.20.1 Close central heating flow and return valves, by ½ turn to reveal blue indicators, and drain the appliance through the safety valve. Open the safety valve by ¼ turn of the knob.

8.20.2 Pressure gauge (fig 48)
Part no. 4472 Fig 49

Trace capillary from back of gauge to connecting point on heating manifold.

Unscrew union on manifold.

Remove and clean off washer remnants.

Squeeze plastic locking lugs behind fascia and press gauge from aperture.

Refix in reverse order following original route for capillary.

8.20.3 Temperature gauge (fig 48)
Part no. 4441 Fig no 49

Trace capillary to sensor. Remove split pin from carrier tube and withdraw sensor. Remove clip from capillary tube.

Squeeze plastic locking lugs behind fascia and press gauge from aperture.

Re-assemble in reverse order ensuring locking lugs are located in the grooves, split pin is secure and capillary clip is refixed.