

# Easi-Flo le

## Water heater

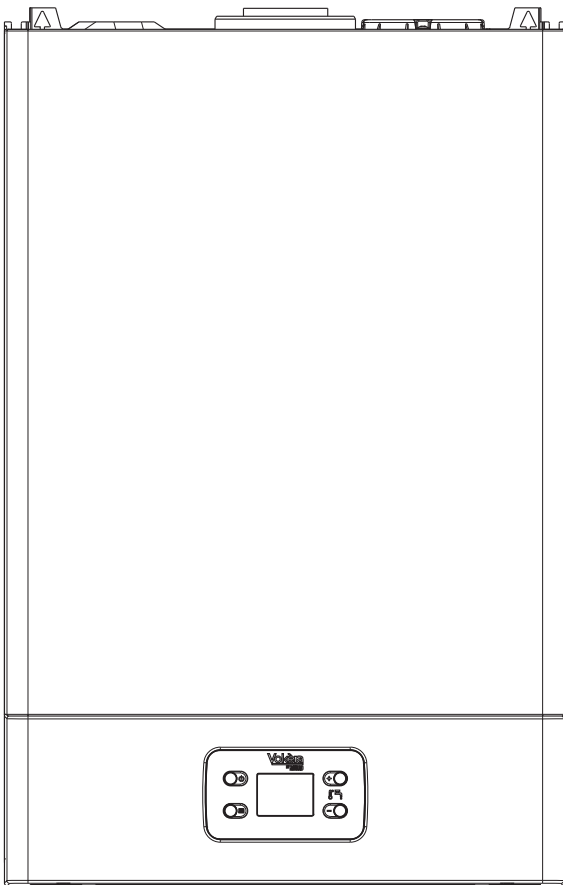

### Installation & Servicing Instructions



G.C. N. 52-094-10 (NG)  
G.C. N. 52-094-11 (LPG)

THESE INSTRUCTIONS  
TO BE RETAINED  
BY USER



Vokèra is a licensed member of the Benchmark scheme which aims to improve the standards of installation and commissioning of domestic hot water systems in the UK.

The **Vokera Easi-Flo** le water heater complies with:

- Regulation (EU) 2016/426
- Electromagnetic Compatibility Directive 2014/30/EU
- Low Voltage Directive 2014/35/EU
- Ecodesign Directive 2009/125/CE for energy-related products
- Regulation (EU) 2017/1369 Energy labelling
- Delegated Regulation (EU) No. 812/2013
- Delegated Regulation (EU) No. 814/2013.



<b>1</b>	<b>GENERAL</b>	<b>3</b>	<b>6</b>	<b>COMMISSIONING</b>	<b>18</b>
1.1	General warnings . . . . .	3	6.1	Gas supply installation . . . . .	18
1.2	Fundamental safety rules . . . . .	3	6.2	Water pipe work . . . . .	18
<b>2</b>	<b>DESCRIPTION</b>	<b>3</b>	6.3	Pre-operation checks . . . . .	18
2.1	Structure . . . . .	3	6.4	Initial lighting . . . . .	18
2.2	Technical data . . . . .	4	6.5	Checking the burner pressure . . . . .	18
2.3	Water circuit . . . . .	5	6.6	Setting the outlet temperature . . . . .	18
2.4	External wiring . . . . .	6	6.7	Final checks . . . . .	18
			6.8	Instructing the user . . . . .	18
<b>3</b>	<b>GENERAL REQUIREMENTS</b>	<b>7</b>	<b>7</b>	<b>SERVICING</b>	<b>19</b>
3.1	Terminal position for fan assisted appliance . . . . .	7	7.1	General . . . . .	19
3.2	Principle components . . . . .	7	7.2	Routine annual servicing . . . . .	19
3.3	Mode of operation . . . . .	7	7.3	Replacement of components . . . . .	19
3.4	Safety devices . . . . .	7	7.4	Component removal procedure . . . . .	19
3.5	Related documents . . . . .	8	7.5	High limit thermostat . . . . .	19
3.6	Location of appliance . . . . .	8	7.6	Flow switch . . . . .	19
3.7	Gas supply . . . . .	8	7.7	Burner . . . . .	20
3.8	Flue system . . . . .	8	7.8	Flue fan . . . . .	20
3.9	Air supply . . . . .	8	7.9	Heat exchanger . . . . .	20
3.10	Water pipe work . . . . .	8	<b>8</b>	<b>CHECKS, ADJUSTMENTS, AND FAULT FINDING</b>	<b>21</b>
3.11	Pipework . . . . .	8	8.1	Checking appliance operation . . . . .	21
3.12	Drain cocks . . . . .	8	8.2	Appliance mode of operation . . . . .	21
3.13	Electrical supply . . . . .	8	8.3	Checking and adjusting burner pressure . . . . .	21
3.14	Timber framed buildings . . . . .	8	8.4	Maintenance . . . . .	21
<b>4</b>	<b>INSTALLATION</b>	<b>9</b>	8.5	External faults . . . . .	22
4.1	Delivery . . . . .	9	8.6	Electrical checks . . . . .	22
4.2	Contents . . . . .	9	8.7	Operating faults and reset . . . . .	22
4.3	Unpacking . . . . .	9	8.8	Fault finding . . . . .	22
4.4	Preparation for mounting the appliance . . . . .	9	<b>9</b>	<b>L.P.G. INSTRUCTIONS</b>	<b>23</b>
4.5	Fitting the flue . . . . .	9	9.1	Gas supply . . . . .	23
4.6	Connecting the gas and water . . . . .	12	9.2	Gas supply installation . . . . .	23
4.7	Electrical connections . . . . .	13	9.3	Checking and adjusting burner pressure . . . . .	23
4.8	CASING REMOVAL . . . . .	13	<b>10</b>	<b>GAS TRANSFORMATION</b>	<b>23</b>
4.9	Emptying the water heater . . . . .	13	10.1	Adjustments . . . . .	24
<b>5</b>	<b>USER</b>	<b>14</b>			
5.1	Do's and don't's . . . . .	14			
5.2	Guarantee registration card . . . . .	14			
5.3	Benchmark log book . . . . .	14			
5.4	How does it work? . . . . .	14			
5.5	Diagnostic fault indicator . . . . .	14			
5.6	Control panel . . . . .	14			
5.7	Description of icons . . . . .	14			
5.8	Selecting functions . . . . .	14			
5.9	Before switching on . . . . .	15			
5.10	Lighting the appliance . . . . .	15			
5.11	Temporary shutdown . . . . .	16			
5.12	Shut down for long periods . . . . .	16			
5.13	How to care for the appliance . . . . .	16			
5.14	What if i suspect a gas leak . . . . .	16			
5.15	What if the appliance is due its annual service . . . . .	16			
5.16	What if i need to call an engineer . . . . .	16			
5.17	Parameters menu . . . . .	16			
5.18	Reset to factory settings . . . . .	17			
5.19	Reset to factory settings . . . . .	17			

The following symbols are used in some parts of this booklet:



**CAUTION** = actions that require special care and suitable preparation



**PROHIBITED** = actions that absolutely must NOT be carried out

# 1 GENERAL

## 1.1 General warnings

- ⚠ After having removed the packaging, check that the material supplied is intact and complete; if this is not the case, contact **Vokera Ltd**.
- ⚠ The **Easi-Flo** water heater must be installed by qualified personnel as detailed under any current standards and law applicable and with the instructions provided by **Vokera Ltd** in the manual supplied with the appliance.
- ⚠ The water heater must be used for the purposes it has been expressly manufactured. **Vokera Ltd** declines all contractual and extra-contractual liability for damage caused to persons, animals or things, due to errors in installation, control, servicing or improper use.
- ⚠ In the event of water leaks, disconnect the water heater from the mains power supply, close the water supply and promptly notify **Vokera Ltd** or other professionally qualified personnel.
- ⚠ If the water heater is not used for an extended period, the following minimum operations must be completed:
  - move the main system switch to "off".
- ⚠ Servicing must be performed on the water heater at least once a year.
- ⚠ This manual is an integral part of the water heater and as a consequence must be kept with care. If the manual is damaged or lost, contact **Vokera Ltd** for another copy.
- ⚠ When the product reaches the end of its life it should not be disposed of as solid urban waste but should be brought to a separated waste collection facility.
- ⚠ This appliance should not be operated by children younger than 8 years, people with reduced physical, sensory or mental capacities, or inexperienced people who are not familiar with the product, unless they are given close supervision or instructions

on how to use it safely and are made aware by a responsible person of the dangers its use might entail. Children must not play with the appliance. It is the user's responsibility to clean and maintain the appliance. Children should never clean or maintain it unless they are given supervision.

## 1.2 Fundamental safety rules

The use of products that operate on fuel, electricity and water requires a number of fundamental safety rules to be observed, including:

- ⊘ The water heater must not be used by children or invalid persons without supervision.
- ⊘ Electrical devices or appliances, such as switches, household appliances, etc. must not be used if there is the smell of gas or unburned fuel. In this case:
  - ventilate the room by opening doors and windows;
  - close the fuel stopcock;
  - promptly contact **Vokera Ltd**, your gas supplier or other professionally qualified personnel.
- ⊘ Do not touch the water heater when barefoot or with wet parts of the body.
- ⊘ No service or cleaning operations may be performed without first having disconnected the water heater from the mains power supply, moving the main system switch to "off".
- ⊘ The safety or control devices must not be adjusted without the authorisation and written instructions from the manufacturer of the water heater.

# 2 DESCRIPTION

The **Vokera Easi-Flo** is an instantaneous water heater, which - by design - incorporates electronic ignition, NTC temperature control and a coaxial flue that can be rotated – horizontally – through 360 degrees for various horizontal or vertical applications.

The **Easi-Flo** le can also be used with the **Vokera** twin flue system.

All installers are asked to follow the Benchmark Scheme by adhering to the Code of Practise, which can be obtained from [www.centralheating.co.uk](http://www.centralheating.co.uk).

## 2.1 Structure

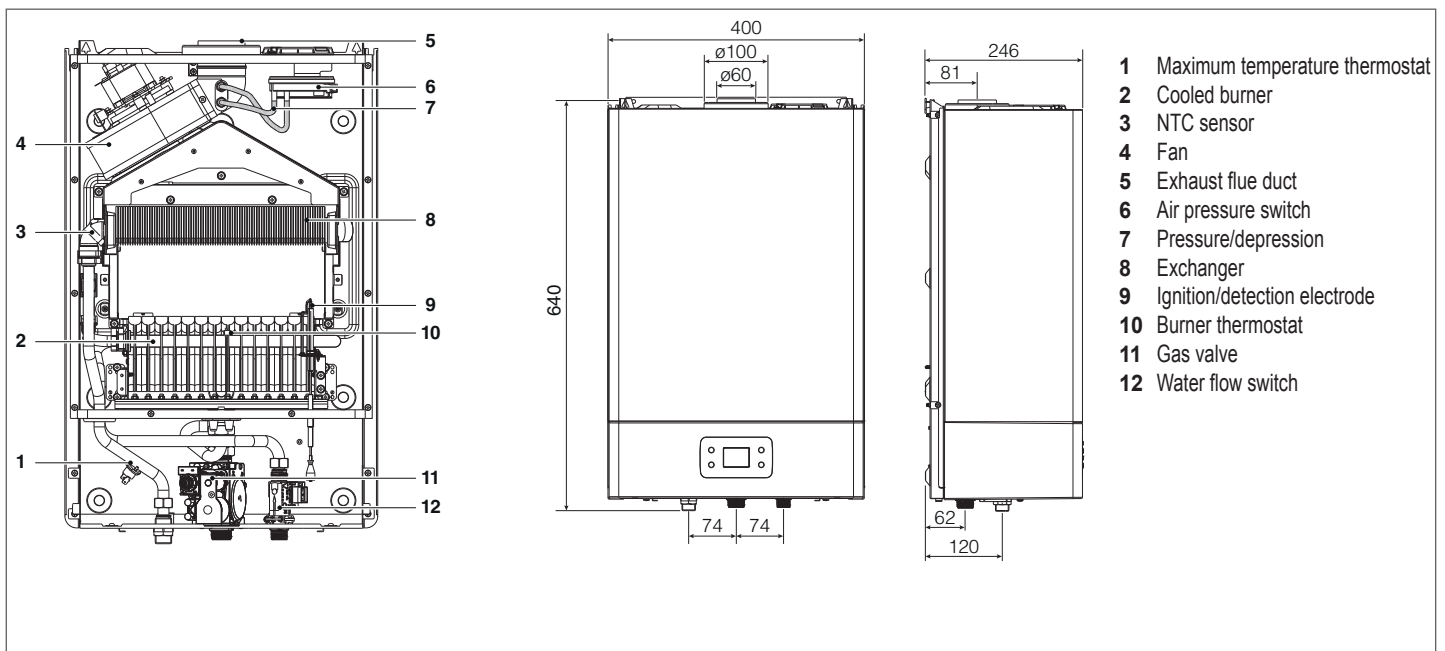

## 2.2 Technical data

DESCRIPTION		Easi-Flo	Units
Nominal heat input		30,00	kW
		25,800	kcal/h
Nominal heat output		27,60	kW
		23.736	kcal/h
Reduced heat input		10,50	kW
		9,030	kcal/h
Reduced heat output		9,89	kW
		8,506	kcal/h
Category		I12H3P	
Destination country		GB - IE	
Configuration type		B22-B52;C12-C12x;C32-C32x;C42-C42x;C52-C52x; C62-C62x;C82-C82x;C92-C92x	
<b>Gas characteristics</b>			
Lower heat output	G20	34,02	MJ/m³S
	G31	88	
Lower Wobbe index (15°C 1013 mbar)	G20	45,67	MJ/m³S
	G31	70,69	
Nominal supply pressure	G20	20	mbar
	G31	37	
Maximum gas flow rate in DHW mode	G20	3,17	Sm³/h
	G31	2,33	
Maximum DHW pressure	G20	15,20	mbar
	G31	35,30	
Ø main burner nozzle	G20	0,85	mm
	G31	0,52	
Flue gas mass flow rate (max/min)	G20	20,887 - 12,733	g/s
	G31	20,664 - 12,006	
Nozzles		28	n.
Ø gas connection		3/4"	
<b>Concentric flue gas outlet pipes</b>			
Diameter		60/100	mm
Maximum length		2,6	m
Loss due to 45°/90° bend		1/1,5	m
Wall hole		105	mm
<b>Separate flue gas outlet pipes</b>			
Diameter		80	mm
Maximum length		6+6	m
Loss due to 45°/90° bend		1,2/1,7	m
Flue gas temperature (max/min)	G20	135-72	°C
	G31	137-71	
Minimum pressure		0,2	bar
Nominal pressure		2	bar
Maximum pressure		10	bar
DHW minimum flow rate		2	l/min
Quantity of hot water with Δt 30°C		13,2	l/min
Ø water connections		1/2"	
DHW temperature selection range		36-65	°C
Flow regulator		12	l/min
Total electrical power		41	W
Internal fuse		2	A
External fuse		3	A
Power supply voltage		230/50	V/Hz
Protection rating		IPX4D	
<b>Appliance dimensions</b>			
Height		640	mm
Width		400	mm
Depth		246	mm
Net weight		21	kg
<b>Clearances</b>			
Top	150 mm from casing or 25 mm above flue elbow (whichever is applicable)		
Bottom		150	mm
Sides		50	mm
Front		600	mm
<b>Connections</b>			
Cold water		15 (compression)	mm
Hot water		15 (compression)	mm
Gas		15 (copper)	mm

Parameter	Symbol	Value	Unit
Water heating energy efficiency class	-	A	-
Declared load profile	-	XL	-
Water heating energy efficiency	$\eta_{wh}$	82,0	%
Daily fuel consumption	$Q_{fuel}$	24,225	kWh
Annual fuel consumption	AFC	18	GJ
Daily electricity consumption	$Q_{elec}$	0,082	kWh
Annual electricity consumption	AEC	18	kWh
Sound power level, indoors	LWA	51	dB(A)
Emissions of nitrogen oxides	NOx	40	mg/kWh

### 2.3 Water circuit

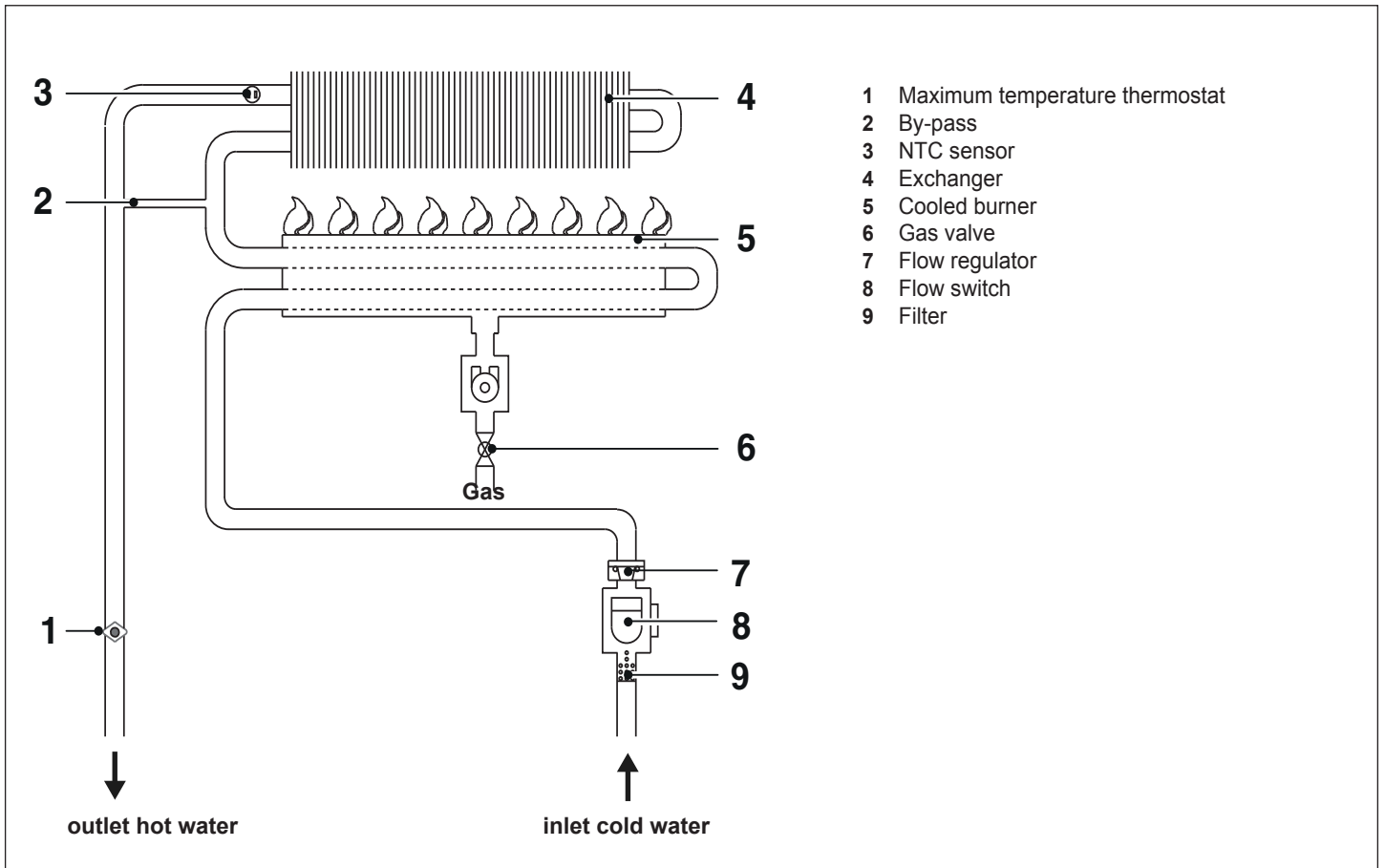

## 2.4 External wiring

The appliance comes with a factory fitted cable that should be connected to a suitable fused isolator or plug. If this is unsuitable and a direct connection to the appliance is required, it must be connected to the appliance as shown in the following diagram. For further advice on the electrical connection, please contact **Vokera** technical on 0844 391 0999.

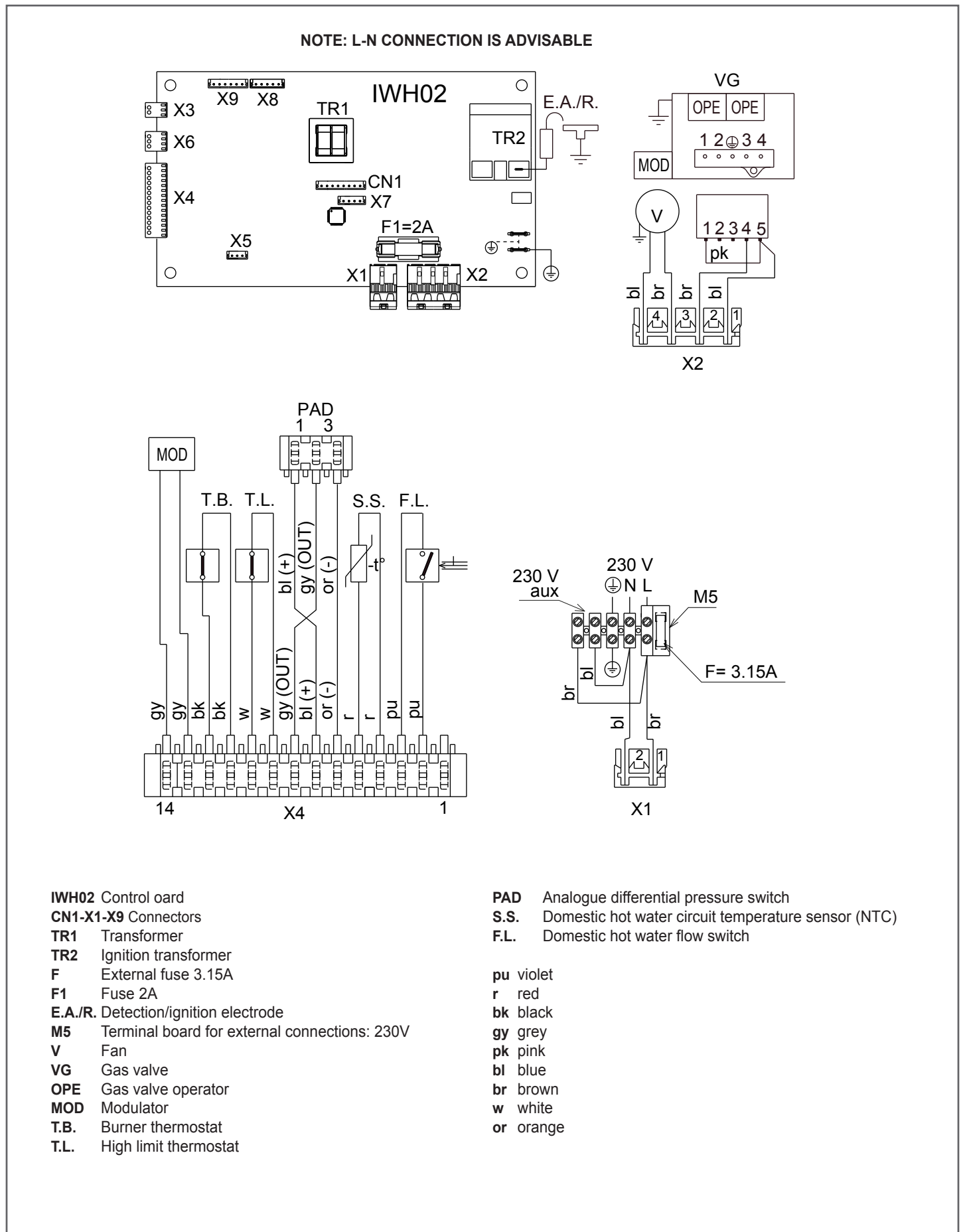

### 3 GENERAL REQUIREMENTS

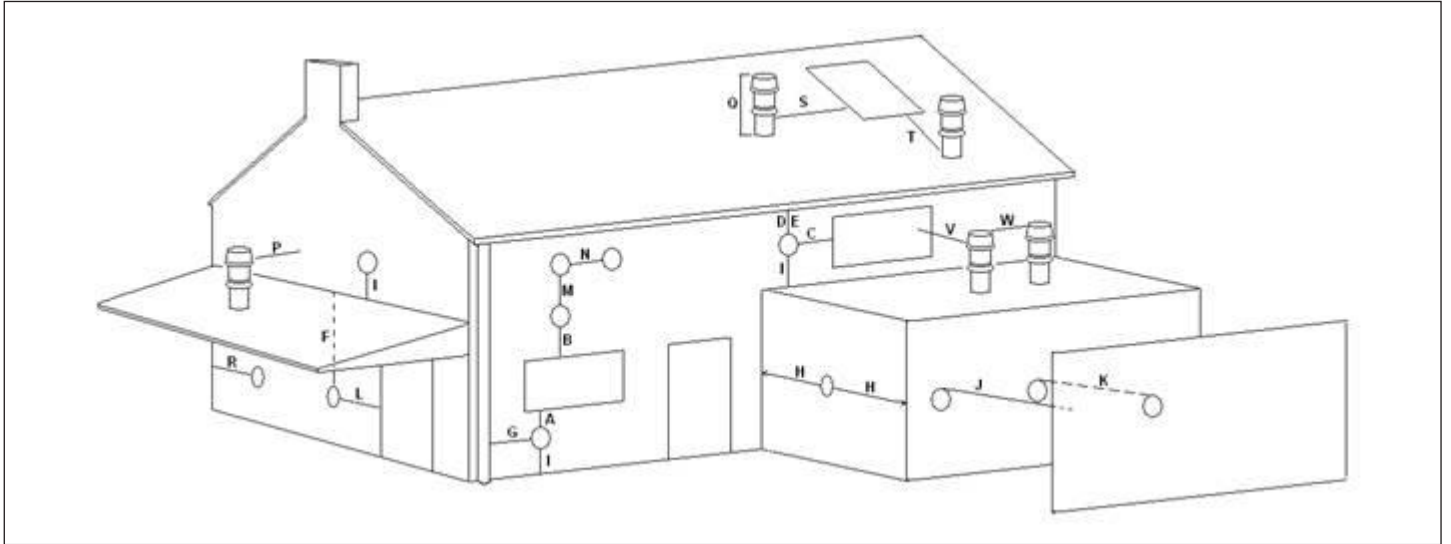

#### 3.1 Terminal position for fan assisted appliance

Key	Location	Minimum distance
A	Below an opening (window, air-brick, etc.)	300 mm
B	Above an opening (window, air-brick, etc.)	300 mm
C	To the side of an opening (window, air-brick, etc.)	300 mm
D	Below gutter, drain-pipe, etc.	25 mm
E	Below eaves	25 mm
F	Below balcony, car-port roof, etc.	25 mm
G	To the side of a soil/drain-pipe, etc.	25 mm (60mm for 80/125 - 5" flue)
H	From internal/external corner	25 mm (60mm for 80/125 - 5" flue)
I	Above ground, roof, or balcony level	300 mm
J	From a surface or boundary facing the terminal	600 mm
K	From a terminal facing a terminal	1200 mm
L	From an opening in the car-port into the building	1200 mm
M	Vertically from a terminal on the same wall	1500 mm
N	Horizontally from a terminal on the same wall	300 mm
P	From a structure to the side of the vertical terminal	300 mm
Q	From the top of the vertical terminal to the roof flashing	As determined by the fixed collar of the vertical terminal
R	To the side of a boundary	300 mm
S	To the side of an opening or window on a pitched roof	600 mm
T	Below an opening or window on a pitched roof	2000 mm
V	From a vertical terminal to an adjacent opening (window, air-brick, etc.)	(call Vokera technical for advice)
W	From a vertical terminal to an adjacent vertical terminal	300 mm (only if both terminals are the same height)

#### 3.2 Principle components

- A fully integrated electronic control board featuring electronic temperature control, self diagnostic fault indicator, continuous gas modulation.
- Electronic ignition with flame supervision.
- Fan.
- Differential air pressure switch.
- Two-stage gas valve.

#### 3.3 Mode of operation

When there is a request for hot water via a hot water outlet or tap, the water flow switch senses water movement thereby energizing the fan, the fan proves the differential air pressure switch which in-turn allows an ignition sequence to begin.

Ignition is sensed by the electronic circuitry to ensure flame stability at the burner. Once successful ignition has been achieved, the electronic circuitry increases the gas rate to maximum or modulates to suit the set requirement.

When the appliance reaches the desired temperature the burner will modulate to maintain the desired temperature. Should the temperature continue to increase, the burner will shut off when the maximum operating temperature is attained.

When the request for hot water has been satisfied the appliance fan may continue to operate to dissipate any residual heat within the appliance.

#### 3.4 Safety devices

When the appliance is in use, safe operation is ensured by:

- a high limit thermostat that over-rides the temperature control circuit to prevent or interrupt the operation of the burner;
- a differential air pressure switch that checks the operation of the fan and flue thereby allowing safe operation of the burner;
- a flame supervision device that will shut off the gas supply to the burner when no flame signal is detected.



Detailed		
BS 5440	Part 1	Flues
BS 5440	Part 2	Flues and ventilation
BS 5546		Installation of hot water supplies for domestic purposes
BS 6891		Low pressure installation pipe
BS 6700		Design, installation, testing and maintenance of services supplying Water for domestic use

**!** This appliance must be installed by a competent person in accordance with the Gas-Safety (Installation & Use) Regulations.

### 3.5 Related documents

The installation of this water heater must be in accordance with the relevant requirements of the Gas-Safety (Installation & Use) Regulations, the Water supply (water fittings) Regulations, the Water Byelaws Scotland, the Building Standards (Scotland) Regulation and Building Standards (Northern Ireland) Regulations. It should be in accordance also with any relevant requirements of the local authority and the relevant recommendations of the following British Standard Codes of Practice.

### 3.6 Location of appliance

The appliance may be installed in any room or internal space, although particular attention is drawn to the requirements of the current I.E.E. wiring regulations, and in Scotland, the electrical provisions of the Building Regulations, with respect to the installation of the appliance in a room or internal space containing a bath or shower.

When an appliance is installed in a room or internal space containing a bath or shower, the appliance or any control pertaining to it must not be within reach of a person using the bath or shower.

The location chosen for the appliance must permit the provision of a safe and satisfactory flue and termination. The location must also permit an adequate air supply for combustion purposes and an adequate space for servicing and air circulation around the appliance. Where the installation of the appliance will be in an unusual location special procedures may be necessary, BS 6798 gives detailed guidance on this aspect. A compartment used to enclose the appliance must be designed and constructed specifically for this purpose. An existing compartment/cupboard may be utilised provided that it is modified to suit. Details of essential features of compartment/cupboard design, including airing cupboard installations, are given in BS 6798. This appliance is not suitable for external installation.

### 3.7 Gas supply

The gas meter – as supplied by the gas supplier – must be checked to ensure that it is of adequate size to deal with the maximum rated input of all the appliances that it serves. Installation pipes must be fitted in accordance with BS 6891. Pipe-work from the meter to the appliance must be of adequate size. Pipes of a smaller size than the appliance gas inlet connection must not be used. The installation must be tested for soundness in accordance with BS 6891. If the gas supply serves more than one appliance, it must be ensured that an adequate supply is maintained to each appliance when they are in use at the same time.

#### NOTE

It is reasonable to expect a drop of 2 mbar between the inlet gas cock and the appliance test nipple.

### 3.8 Flue system

The terminal should be located where the dispersal of combustion products is not impeded and with due regard for the damage and discoloration that may occur to building products located nearby.

The terminal must not be located in a place where it is likely to cause a nuisance. In cold and/or humid weather, water vapor may condense on leaving the terminal; the effect of such plumbing must be considered. If installed less than 2m above a pavement or platform to which people have access (including balconies or flat roofs) the terminal must be protected by a guard of durable material. The guard must be fitted centrally over the terminal.

Refer to BS 5440 Part 1, when the terminal is 0,5 metres (or less) below plastic guttering or 1 metre (or less) below painted eaves.

### 3.9 Air supply

The following notes are intended for general guidance only. This appliance is a room sealed, fan-flued water heater, consequently it does not require a permanent air vent for combustion air supply. When installed in a cupboard or compartment, ventilation for cooling purposes is also not required.

### 3.10 Water pipe work

Detailed recommendations are given in BS 5449 Part 1 and BS 6798. The following notes are for general guidance only.

### 3.11 Pipework

It is recommended that copper tubing to BS 2871 Part 1 is used in conjunction with soldered capillary joints. Where possible pipes should have a gradient to ensure air is carried naturally to an outlet and that water flows naturally to drain cocks. Pipes should be insulated to avoid heat loss and in particular to avoid the possibility of freezing. Particular attention should be paid to pipes passing through ventilated areas such as under floors, loft space, and void areas.

### 3.12 Drain cocks

These must be located in accessible positions to facilitate draining of the appliance and all water pipes connected to the appliance. The drain cocks must be manufactured in accordance with BS 2879.

### 3.13 Electrical supply

The appliance is supplied for operation on 230V @ 50Hz electrical supply; it must be protected with a 3-amp fuse. The method of connection to the mains electricity supply must allow for complete isolation from the supply. The preferred method is by using a double-pole switch with a contact separation of at least 3mm. The switch must only supply the appliance. Alternatively an un-switched shuttered socket with a fused 3-pin plug both complying with BS 1363 is acceptable.

### 3.14 Timber framed buildings

If the appliance is to be fitted in a timber framed building, it should be fitted in accordance with the Institute of Gas Engineers publication (IGE/ UP/7) "Guide for Gas Installations in Timber Frame Buildings".

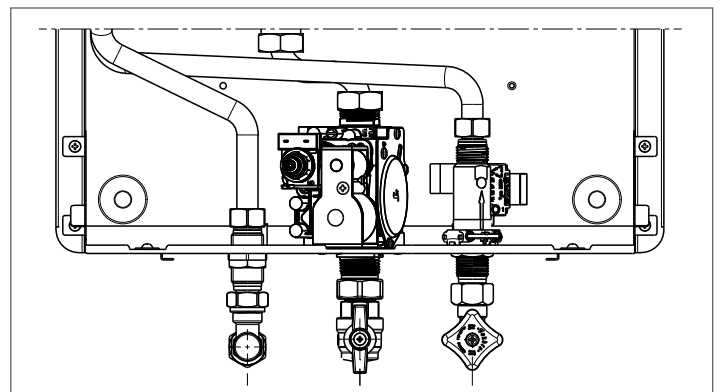



## 4 INSTALLATION

### 4.1 Delivery

The appliance is delivered in a heavy-duty cardboard carton. Lay the carton on the floor with the writing the correct way up.

### 4.2 Contents

Contained within the carton is:

- the appliance;
- the wall mounting bracket and stand-off brackets;
- template;
- an accessories pack containing the appliance service valves and washers;
- the instruction pack containing the installation & servicing instructions, user instructions and a 3-amp fuse.

### 4.3 Unpacking

At the top of the carton pull both sides open – do not use a knife – unfold the rest of the carton from around the appliance, carefully remove all protective packaging from the appliance, and lay the accessories etc. to one side.

### 4.4 Preparation for mounting the appliance

The appliance should be mounted on a smooth, vertical, surface, which must be capable of supporting the full weight of the appliance. Care should be exercised when determining the position of the appliance with respect to hidden obstructions such as pipes, cables, etc. When the position of the appliance has been decided – using the template supplied – carefully mark the position of the wall-mounting bracket and flue-hole (if applicable).

- ⚠ Position the cartoon template and trace the two upper holes  $\varnothing 8$  mm. Trace the two lower holes  $\varnothing 8$  mm at a distance from the upper holes of 579 mm.
- Fix the stand-off brackets (the stand-off brackets should only be used if the flue is exiting to the rear).

- ⚠ Attach the wall mounting bracket.

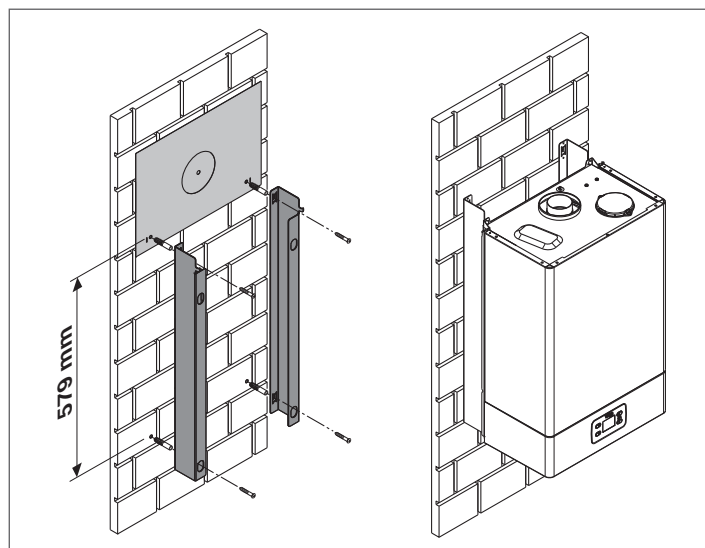
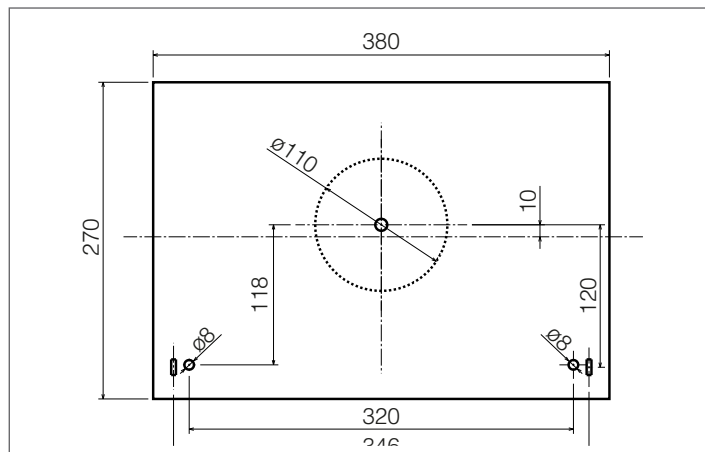

### MAXIMUM FLUE LENGTHS

Flue system	Easi-Flo	UM
Concentric Horizontal	2.60	mt
Concentric Vertical	3.60	mt
Twin flue	6 + 6	mt

### 4.5 Fitting the flue

The top flue outlet permits both horizontal and vertical flue applications to be considered, alternatively, the Vokèra twin flue system can be utilised if longer flue runs are required.

#### Concentric horizontal flue

(For concentric vertical flue, see pag. 10).

(For twin flue applications, see pag. 11).

The appliance can be used with either the Vokèra 60/100mm concentric Uni-flue system or the optional Vokera twin flue system.

#### NOTE

These instructions relate only to the Vokèra Uni-Flue 60/100mm concentric flue system. The appliance flue outlet elbow can be rotated through 360° on its vertical axis. In addition the flue may be extended from the outlet elbow in the horizontal plane. A reduction must also be made to the maximum length (see table below) when additional bends are used.

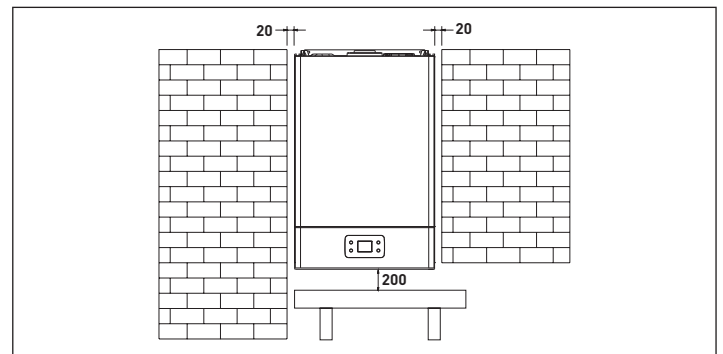

#### Reduction for additional bends

Bend	Reduction in maximum flue length for each bend	
45° bend	1.0 metre (60/100)	mt
90° bend	1.5 metre (60/100)	mt

#### Horizontal flue terminals and accessories

Part no.	Description	Min-Max length
2359029	Horizontal flue kit	833 mm (dimension 'X')
2359119	Telescopic flue kit	
2359069	750 mm extension	750 mm
2359079	1500 mm extension	1500 mm
2359089	Telescopic extension	350-490 mm
2359049	45° bend (pair)	220mm
2359059	90° bend	N/A
529	Wall bracket (5)	N/A

Using the template provided (A), mark and drill a 125mm hole for the passage of the flue pipe. The hole should have a 1° drop from the appliance to outside, to eliminate the possibility of rainwater entering the appliance via the flue.

The fixing holes for the wall-mounting bracket should now be drilled and plugged, an appropriate type and quantity of fixing should be used to ensure that the bracket is mounted securely.

Once the bracket has been secured to the wall, mount the appliance onto the bracket.

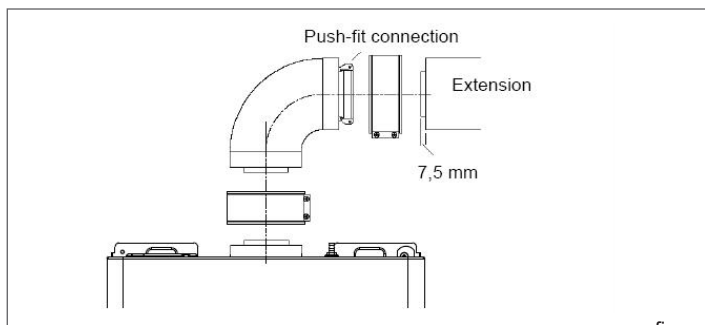
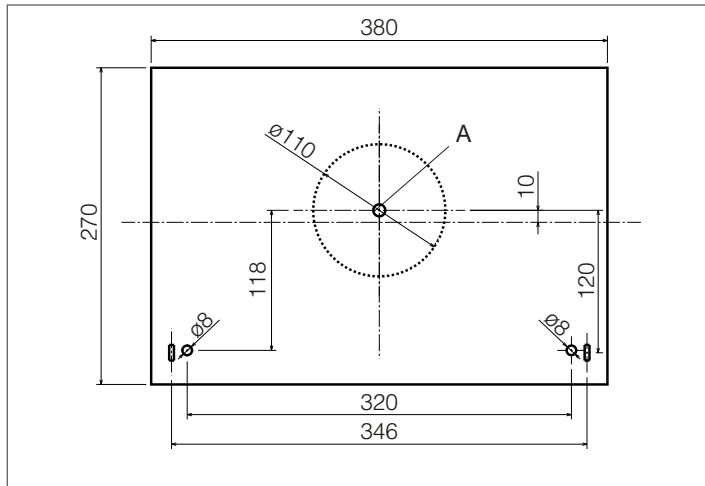

#### Fitting the horizontal flue kit

Carefully measure the distance from the centre of the appliance flue outlet to the face of the outside wall (dimension 'X'). Ensure the inner (60mm) pipe is fully inserted into the outer (100mm) pipe (when the inner pipe is fully inserted, it stands proud of the outer pipe by 7.5mm). Add 32mm to dimension 'X' to give the overall flue length (dimension 'Y').

Maximum length Ø 60-100 mm (m)	Loss of load (m)	
	45° bend	90° bend
2,6	1	1,5

#### NOTE

The standard horizontal flue kit (part no. 2359029) is suitable for a distance (dimension 'Y') of up to 865mm.

The telescopic flue kit (part no. 2359119) is suitable for a distance (dimension 'Y') of up to 600mm.

Dimension 'Y' is measured from the end of the terminal to the end of the outer (100mm) pipe. The internal trim should be fitted to the flue pipe before connection of the 90° bend.

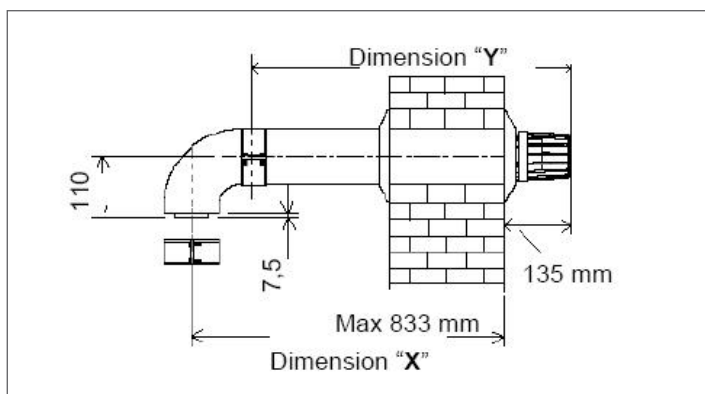

#### Extending the flue

The horizontal flue system can be extended using bends and/or extensions from the Uni-Flue range.

Connect the bend – supplied with the terminal kit – to the top of the appliance using the clips, screws, & gaskets supplied. The additional bends & extensions have an internal push-fit connection, care should be taken to ensure that the correct seal is made when assembling the flue system. Connect the required number of flue extensions or bends (up to the maximum equivalent flue length) to the flue terminal using the clips, screws, & gaskets supplied (see fig. a & fig. b). The interior trim should be fitted at this point.

#### NOTE

When cutting an extension to the required length, you must ensure that the excess is cut from the plain end of the extension, and that the inner (60mm) pipe is 7.5mm longer than outer (100mm) pipe. Remove any burrs, and check that any seals are located properly.

You must ensure that the entire flue system is properly supported and connected.

Seal the flue assembly to the wall using cement or a suitable alternative that will provide satisfactory weatherproofing. The exterior trim can now be fitted.

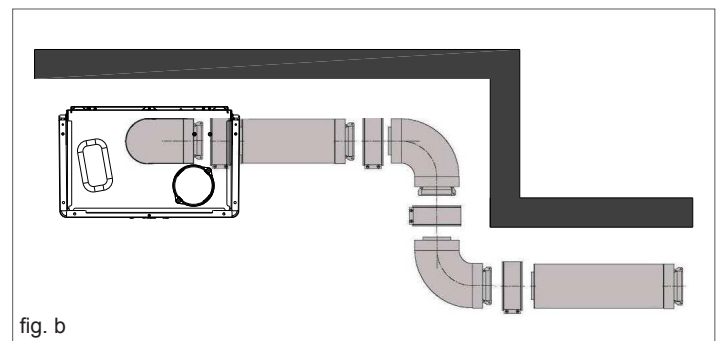

#### Concentric vertical flue

The appliance can be used with either the Vokèra 60/100mm concentric Uni-flue system or the optional Vokera twin flue system.

Maximum length Ø 60-100 mm (m)	Loss of load (m)	
	45° bend	90° bend
3,6	1	1,5

#### NOTE

These instructions relate only to the Vokèra 60/100mm concentric flue system. For specific details on the installation of the Vokera twin flue system please refer to the instructions supplied.

The vertical flue terminal can be connected directly to the appliance flue outlet. Alternatively, an extension or bend can be connected to the appliance flue outlet if desired, however if additional bends are fitted, a reduction must be made to the maximum flue length (see table below).

#### Reduction for bends

Bend	Reduction in maximum flue length for each bend	
45° bend	1.0 metre (60/100)	mt
90° bend	1.5 metre (60/100)	mt

#### Vertical flue terminal and accessories

Part No.	Description	Length
2359039	Vertical flue terminal	1.0 metre
531	Pitched roof flashing plate	N/A
532	Flat roof flashing plate	N/A
2359069	750 mm extension	750 mm
2359079	1500 mm extension	1500 mm
2359049	45° bend (pair)	N/A
2359059	90° bend	N/A
529	Wall bracket (5)	N/A

Using the dimensions given in "fig. C" as a reference, mark and cut a 125mm hole in the ceiling and/or roof.

Fit the appropriate flashing plate to the roof and insert the vertical flue terminal through the flashing plate from the outside, ensuring that the collar on the flue terminal fits over the flashing.

The fixing holes for the wall-mounting bracket should now be drilled and plugged, an 'appropriate type and quantity of fixing should be used to ensure that the bracket is mounted securely. Once the bracket has been secured to the wall, mount the appliance onto the bracket.

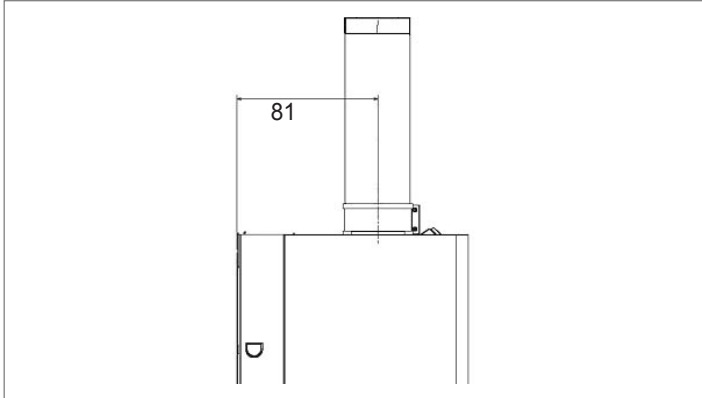

fig. c

**IMPORTANT**

The vertical flue terminal is 1.0 metre in length and cannot be cut; therefore it may be necessary to adjust the height of the appliance to suit or use a suitable extension.

Connect the vertical flue assembly to the appliance flue spigot using the 100mm clip, gasket & screws (supplied), ensuring the correct seal is made. The flue support bracket (supplied with the vertical flue kit) can now be fitted.

If the vertical flue requires extension/s or additional bend/s, connect the required number of flue extensions or bends (up to the maximum equivalent flue length) between the appliance and vertical flue assembly.

**NOTE**

When cutting an extension to the required length, you must ensure that the excess is cut from the plain end of the extension. Remove any burrs, and check that any seals are located properly.

You must ensure that the entire flue system is properly supported and connected.

**Twin flue system**

The Vokèra twin flue system enables greater flue distances to be achieved than that of a concentric flue system. It can be used for horizontal or vertical applications, however the twin flue system must be converted to the dedicated concentric flue kit for termination. It is essential that the installation of the twin flue system be carried out in strict accordance with these instructions

Maximum length Ø 80 mm (m)	Loss of load (m)	
	45° bend	90° bend
6+6	1,2	1,7

**Guidance notes on twin flue installation**

- The flue must have a fall back of 3° back to the appliance to allow any condensate that forms in the flue system to drain via the condensate drain. Consideration must also be given to the fact that there is the possibility of a small amount of condensate dripping from the terminal.
- Ensure that the entire flue system is adequately supported, use at least one bracket for each extension.
- Extreme care must be taken to ensure that no debris is allowed to enter the flue system at any time.
- As the exhaust outlet pipe can reach very high temperatures it must be protected to prevent persons touching the hot surface.

Bend	Reduction in maximum flue length for each bend	
45° bend	1.2 metre	mt

Bend	Reduction in maximum flue length for each bend	
90° bend	1.7 metre	mt

**Twin flue accessories**

Part No.	Description	Length
20006933	Twin adapter kit	N/A

**Mounting the appliance**

The fixing holes for the wall-mounting bracket should now be drilled and plugged, an appropriate type and quantity of fixing should be used to ensure that the bracket is mounted securely. Once the bracket has been secured to the wall, mount the appliance onto the bracket.

**Installation of twin adaptor kit**

- Insert the exhaust connection manifold (A) onto the appliance flue outlet.
- Remove the blanking plate (located to the left of the appliance flue outlet) and – using the same screws – install the air inlet plate (B).
- Using the hole in the exhaust connection manifold as a guide, drill a 3mm hole in the appliance flue spigot and secure the exhaust manifold connection to the flue spigot using the screw provided (C).
- Using the two holes in the air inlet plate as a guide, drill a 3mm hole in each and secure the air inlet pipe/bend using the screws provided.

The twin flue pipes extensions and accessories can now be installed by pushing together (the plain end of each extension or bend should be pushed approximately 50mm into the female socket of the previous piece).

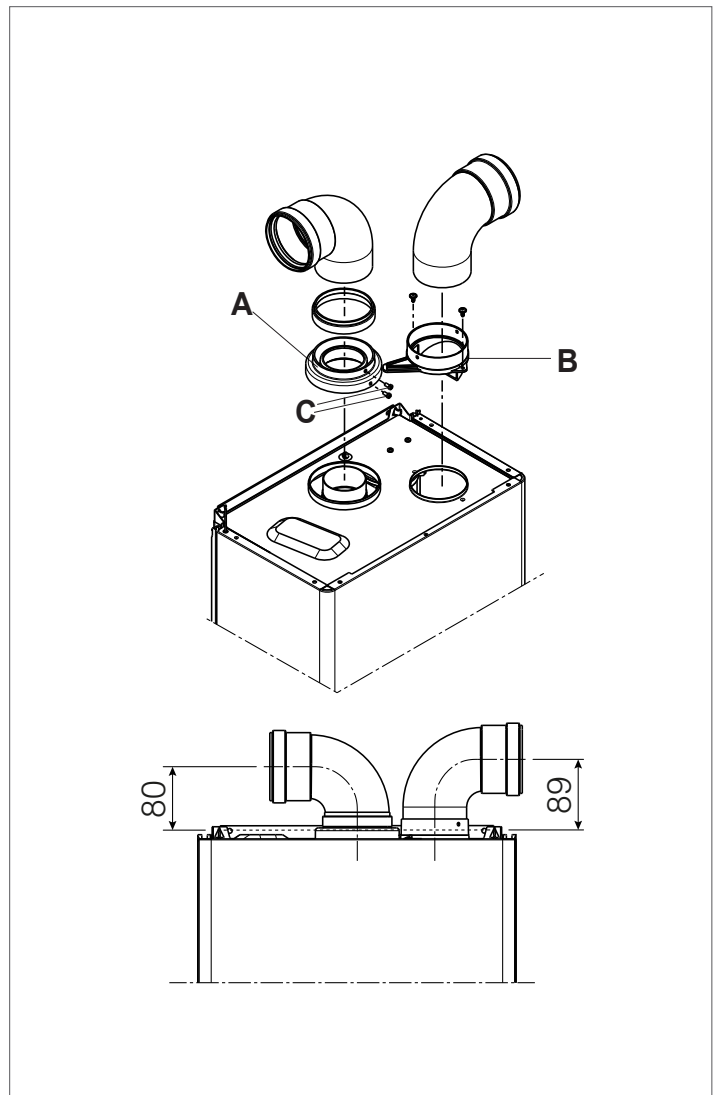

**Horizontal termination**

- The twin flue system must be converted to the dedicated concentric

flue kit for termination.

- The horizontal terminal is supplied with a built-in converter box and cannot be shortened.
- A 130mm hole is required for the passage of the concentric terminal through the wall.
- The air inlet pipe must always be level with or below, that of the exhaust pipe.

Depending on site conditions it may be preferable to install the terminal assembly prior to fitting the twin flue pipes.

Mark and drill a level 130mm hole for the passage of the horizontal flue terminal. Insert the terminal assembly into the flue hole.

Push-fit the twin flue pipes onto the concentric to twin converter box ensuring that the exhaust pipe connects to the exhaust connection on the concentric to twin converter.

If necessary cut the plain ends (male) of the twin flue pipes to allow connection to the concentric to twin converter.

#### NOTE

Before cutting twin flue pipes ensure allowances have been made for connection onto the previous piece and onto the concentric to twin converter. The last twin flue pipes must be pushed 50mm onto the male spigots of the concentric to twin converter.

#### NOTE

Seal the flue terminal assembly to the wall using cement or a suitable alternative that will provide satisfactory weatherproofing. The interior and exterior trim can now be fitted.

#### Vertical termination

The twin flue system must be converted to the dedicated concentric flue kit for termination.

- The vertical terminal is supplied with a built-in converter box and cannot be shortened.
- A 130mm hole is required for the passage of the concentric terminal through the ceiling and/or roof.

Depending on site conditions it may be preferable to install the terminal assembly prior to fitting the twin flue pipes.

Fit the appropriate flashing plate to the roof and insert the vertical flue terminal through the flashing plate from the outside, ensuring that the collar on the flue terminal fits over the flashing.

Push-fit the twin flue pipes onto the concentric to twin converter ensuring that the exhaust pipe connects to the exhaust connection on the concentric to twin converter.

If necessary cut the plain ends (male) of the twin flue pipes to allow connection to the concentric to twin converter.

#### NOTE

- Before cutting twin flue pipes ensure allowances have been made for connection onto the previous piece and onto the concentric to twin converter. The last twin flue pipes must be pushed 50mm onto the male spigots of the concentric to twin converter.
- You must ensure that the entire flue system is properly supported and connected.
- Ensure that any horizontal sections of pipe have a 3° fall towards the appliance to allow any condensate that forms in the flue system to drain via the condensate drain. (17mm per 1000mm = 1°).

#### Installation of condensate drain kit

The condensate drain kit must be fitted within 1 metre of the appliance flue outlet. It is recommended that the condensate drain kit should be fitted in the vertical plane, however it can be fitted horizontally with care.

- Fit the first bend to the condensate drain kit or exhaust connection manifold by firmly pushing in to position.
- Using the two holes in the exhaust connection manifold as a guide, drill a 3 mm hole in each and secure using the screws provided.
- Connect the air inlet pipe to the air baffle as above.
- The twin flue pipes extensions and accessories can now be installed by pushing together (the plain end of each extension or bend should be pushed approximately 50 mm into the female socket of the previous piece).

The condensate drain trap must be connected to the drain in accordance with building Regulations or other rules in force.

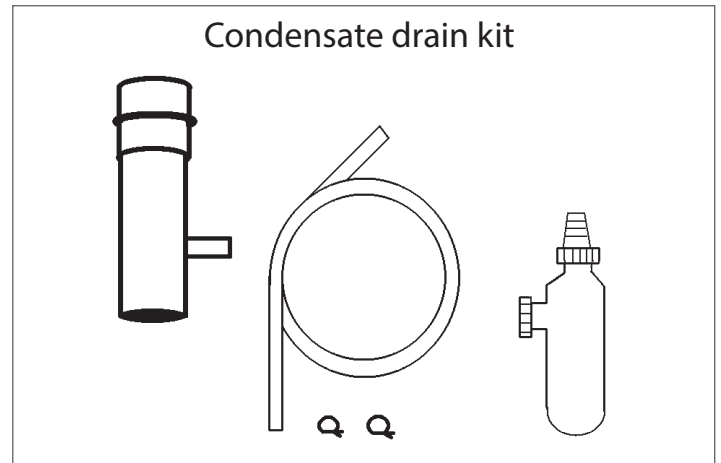

## 4.6 Connecting the gas and water

The appliance is supplied with an accessories pack that contains sealing washers and service valves. The service valves are of the compression type. When connecting pipe work to the valves, tighten the compression end first, then insert the sealing washers before tightening the valve to the appliance.

- ⚠ It will be necessary to hold the valve with one spanner whilst tightening with another.

#### GAS

The appliance is supplied with a 15mm service valve, connect a 15mm pipe to the inlet of the valve and tighten both nuts.

- ⚠ It will be necessary to calculate the diameter of the gas supply pipe to ensure the appliance has an adequate supply of gas.

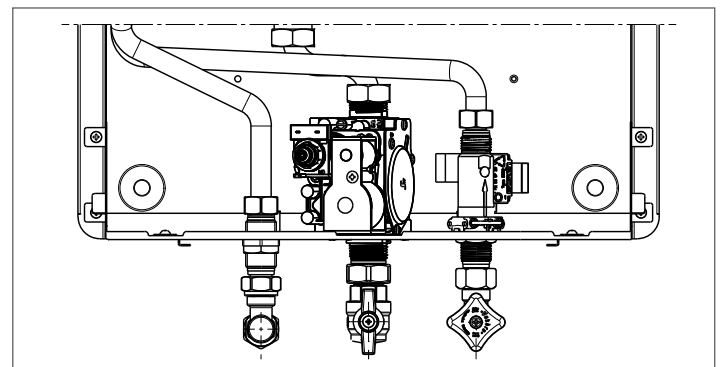

#### COLD INLET

The appliance is supplied with 15mm stopcock for the cold water inlet connection, connect a 15mm pipe to the inlet of the valve and tighten the nut.

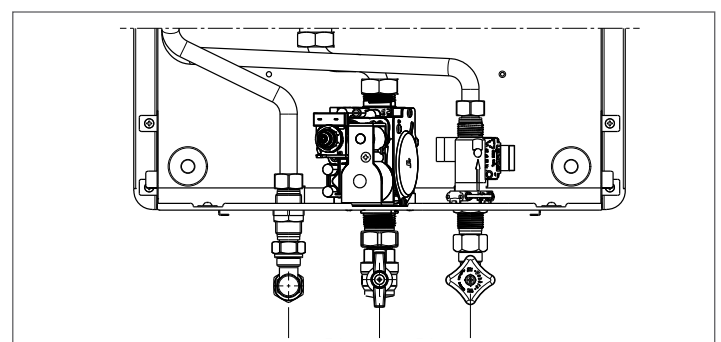

#### HOT WATER OUTLET

The appliance is supplied with 15mm connector for the hot water outlet connection, connect a 15mm pipe to the outlet of the connector and tighten the nut.

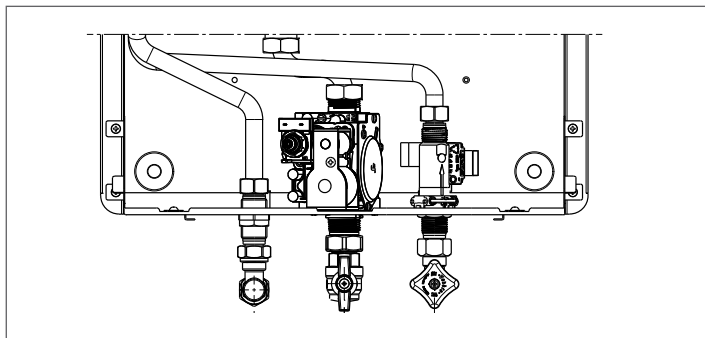

#### 4.7 Electrical connections

The electrical supply must be as specified in 3.13. The appliance is supplied, pre-wired with a 0,9 metre length of flex, connect the wires as follows:

- connect the Brown wire to the L (Live) terminal of the plug or fused isolator;
- connect the Blue wire to the N (Neutral) terminal of the plug or fused isolator;
- connect the Green/Yellow wire to the E (Earth) terminal of the plug or isolator;
- ensure the plug or fused isolator is fitted with a 3-amp fuse.

#### 4.8 CASING REMOVAL

To gain internal access to the appliance you must first remove the casing, proceed as outlined below:

To remove the casing:

- disconnect the appliance from the electric power supply
- remove the two screws A
- pull the casing B forwards
- lift the casing B upwards releasing it from the hooks at the top

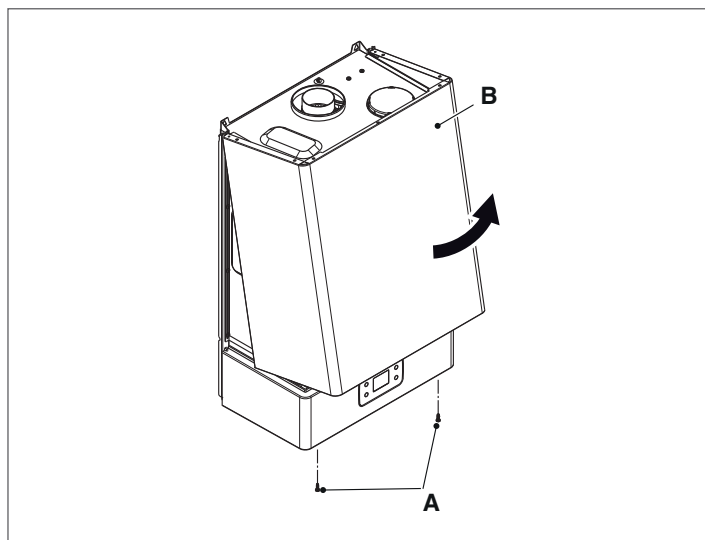

To open the instrument panel:

- remove the screws C
- gently lower the control fascia until it rests;
- store the casing and screws safely until required. Re-fit in the reverse order.

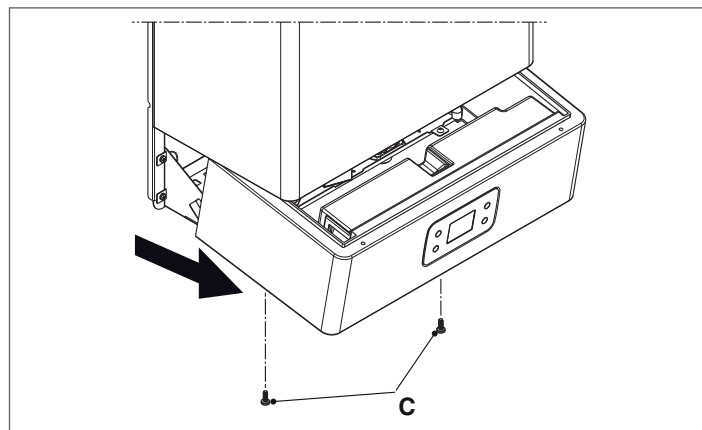

#### 4.9 Emptying the water heater

To empty the water heater:

- turn off the main water supply tap
- open all the water taps
- make sure that the taps at the lowest points of the system allow the water heater to be completely emptied.



## 5 USER

Your Easi-Flo le water heater incorporates the very latest gas water heating technology, and if cared for, will give years of reliable use and efficiency.

Please therefore take some time to read these instructions carefully.

 When the product reaches the end of its life it should not be disposed of as solid urban waste but should be brought to a separated waste collection facility.

### 5.1 Do's and don't's

- Do ensure that you know how to isolate the appliance in an emergency
- Do ensure that you are familiar with the appliance controls
- Do ensure that your installer has completed the appliance log book
- Do not attempt to remove the appliance casing or gain internal access
- Do not hang clothes etc. over the appliance
- Do not forget to have the appliance serviced annually

### 5.2 Guarantee registration card

Please take the time to fill out your guarantee registration card. The completed warranty card should be posted within 30 days of installation.

### 5.3 Benchmark log book

The **Benchmark Log Book** is supplied with your appliance. This important document must be completed during the installation/commissioning of your appliance. All Gas-Safe Registered Installers carry a Gas-Safe ID card, and have a registration number. Both should be recorded in your Benchmark Log Book. You can check your installer by visiting the Gas-Safe website. Failure to install and commission the appliance in accordance with the manufacturers instructions may invalidate the warranty. This does not affect your statutory rights .

### 5.4 How does it work?

Your **Easi-Flo** water heater is an instantaneous gas water heater that operates to produce hot water whenever a hot water outlet (tap) is opened. The **Easi-Flo** will operate whenever a flow of water, through the appliance is sensed. The **Easi-Flo** lights electronically and does not have a pilot light. In the unlikely event of a fault developing with your appliance, the supply of gas to the burner will be terminated automatically.

### 5.5 Diagnostic fault indicator

In the unlikely event of a fault developing, the **Easi-Flo** displays a unique fault indicator that helps identify where the fault lies.

### 5.6 Control panel

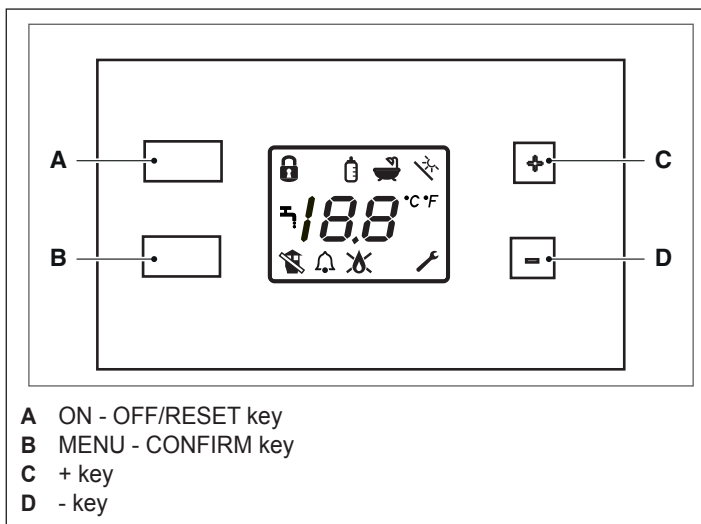

### ON - OFF/RESET key

Allows the appliance to switch on and off. It also allows it to be reset in the event of a fault.









### MENU

Allows the selections to be confirmed, to enter the user menu and, if pressed for more than two seconds, to access the technical menu (in this case you will be asked to enter the password).

### + and - keys

They allow you to navigate the various functions that are available, to change the value of a parameter and to change the temperature that has been set for the domestic hot water.

### 5.7 Description of icons

-  Temperature adjustment lockout
-  Bottle feeder function
-  Function for choosing temperature unit of measurement
-  General alarm
-  Domestic hot water pick-up
-  Flame presence
-  Flame lockout
-  Enter the technical menu
-  Flue gases fault

### 5.8 Selecting functions

Press the MENU (B) key.

Using the "+" e "-" keys it is possible to scroll through the available functions on the display. The icon regarding the selection made, blinks together with the central segments.

In the case of the wrench () the central segments do not appear.

Pressing the MENU (B) key you pass to value setting mode. Either "on" or "oF" is displayed depending on the function that is currently active or inactive. To change the status of the function:

- press the "+" and "-" keys
- press the MENU (B) key to confirm and return to the selection of the functions.

 Keeping either the "+" or "-" key pressed, the fast scrolling mode is activated.

### Button lock function

Allows the keyboard to be locked out. It is activated or deactivated through a combination of the keys ("+" and "-" keys pressed together for 5 seconds).

When the mode is active (lockout) it is not possible to use the keyboard.

### Feeder bottle function

Selecting this function makes it possible to set the maximum temperature at which the water is delivered (maximum 65°C; minimum 36°C). If the function is not active, "oF" appears on the display. If the function is active, the "bottle feeder" temperature that was previously set is displayed.

The maximum value that can be set is established in parameter 11 (see table of parameters).

To change the set value press the MENU (B) key and with the "+" or "-" key select the desired value.

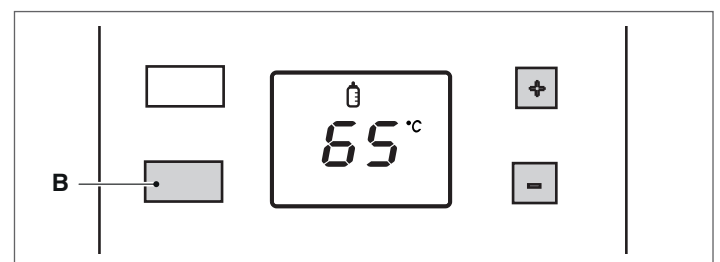

Then confirm the selection by pressing MENU (B) again.

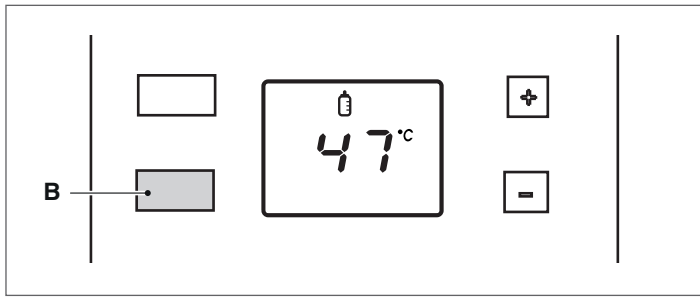

### Function for choosing temperature unit of measurement °C °F

There are two possible units of measurement: Degrees Celsius and Fahrenheit.

The display shows the current unit of measurement. To change the value enter the function (°C °F) and use the "+" and "-" keys.

Then confirm the selection by pressing MENU (B) key.

### Wrench function

When the wrench function is selected, the central segments of the display switch off. Pressing MENU (B) for 2 seconds you pass to the password entry mode (only for professionally qualified personnel) to access the technical menu (see section "Parameters menu").

### Solar

The function is only active if the installation is set up to operate with a solar system.

To exit the functions menu press the "+" or "-" key until "rt" (return) is displayed.

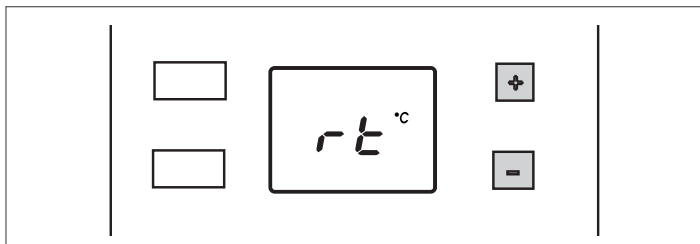

Confirming with the MENU (B) key returns you to the display of the on/standby status.

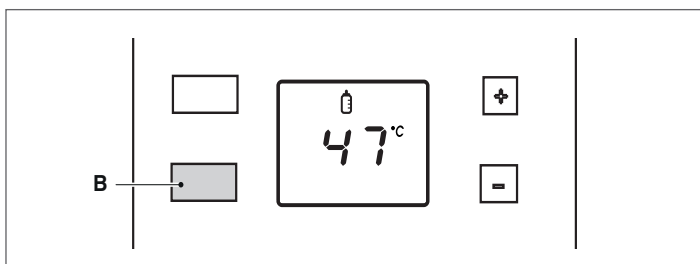

If no action is taken, once 2 minutes have passed the appliance exits the menu and returns to the normal operation screen.

## 5.9 Before switching on

Before switching the appliance on, please familiarise yourself with:

- how to isolate the appliance from the gas, water and electricity supplies;
- the appliance controls.

## 5.10 Lighting the appliance

 The first commissioning of the appliance must be carried out by qualified personnel.

The following checks and operations must be carried out:

- check that the fuel shut-off and water taps of the water system are open

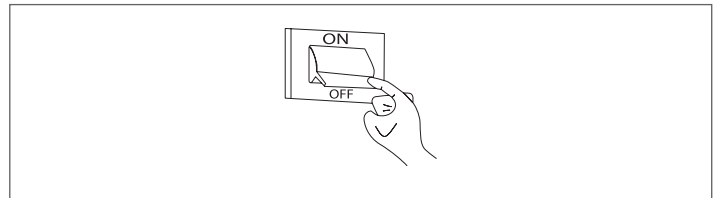
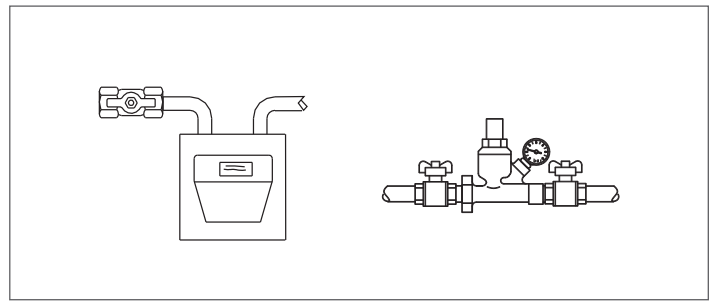

The appliance is powered and is normally off.

The display shows in sequence (from off to on) every 2 seconds a segment of 2 digits to compose the writing "oF" (off). When "oF" is fully present on the display, it remains on for 10 seconds, then it blinks 5 times and switches off for 5 seconds. After which the sequence for switching on the segments restarts. **In this way the appliance ignores every ignition request.**

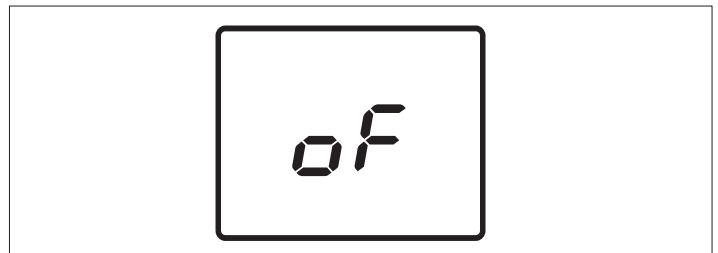

- Press the ON - OFF/RESET (A) button to switch on the appliance.

All the icons on the display appear for 2 seconds. After which only the icons regarding the current operating mode stay on.

In ON mode, the appliance is on with the possibility of producing domestic hot water.

If there is no domestic hot water request, the water heater goes into stand-by.

During this phase the display switches on in sequence (from off to on) every 2 seconds a segment to compose the writing "Sb".

When "Sb" is visible on the display, it remains on for 10 seconds, then it blinks 5 times and switches off for 5 seconds. Then the activation sequence of the segments restarts.

In stand-by, if the temperature measured by the domestic hot water probe is > 65°C the fan is started. When the temperature drops below 65°C the fan remains powered for another minute and then is switched off.

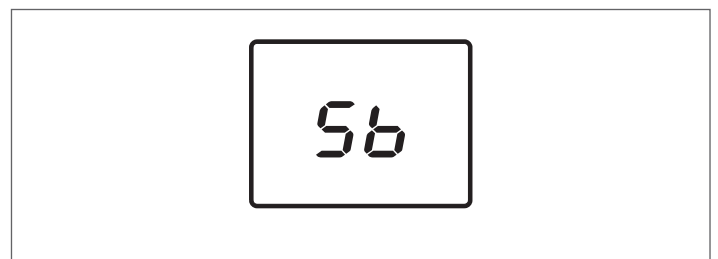

### Domestic hot water pick-up

- Open a domestic hot water tap. Once the time set in the parameter "Domestic Hot Water Waiting Time" has passed (about 0.5 seconds) the display shows the tap symbol and the delivery temperature of the hot water (rounded up in degrees).



- The burner comes on, when the flame is detected, the corresponding symbol is shown on the display.
- The appliance will produce domestic hot water at the temperature set in the parameter "Maximum setpoint of domestic hot water circuit" (see table of parameters).
- When the water tap is shut-off, the boiler switches off and prepares for the next start-up.

The switching on and off of the burner is managed in two modes:

- absolute: burner switching off threshold at 70°C
- correlated: burner switching off threshold when the setpoint of +4°C is reached.

The switching back on point is the same for both modes and is the setpoint -1°C.

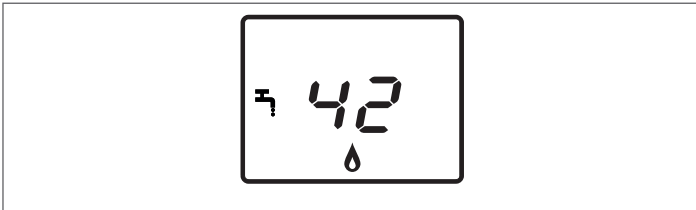

### CHANGING THE DOMESTIC HOT WATER SETPOINT

- Pressing the "+" or "-" key it is possible to change the setpoint for the domestic hot water. With the "+" key the value increases, with the "-" key it decreases.

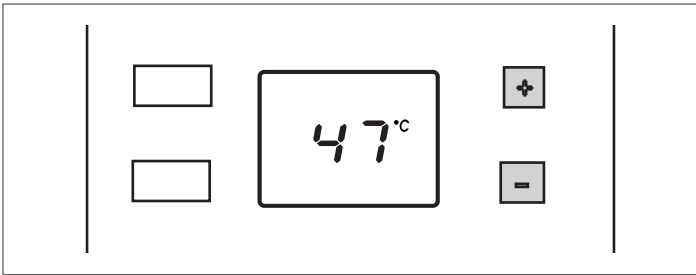

If there is a fault the water heater carries out a "STOP" (see section Operating faults and reset).

### 5.11 Temporary shutdown

In case of temporary absences for weekends, short trips, etc.:

- press the ON-OFF/RESET (A) key
- turn the main system switch to "off".

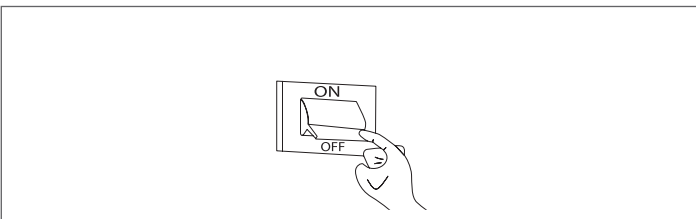
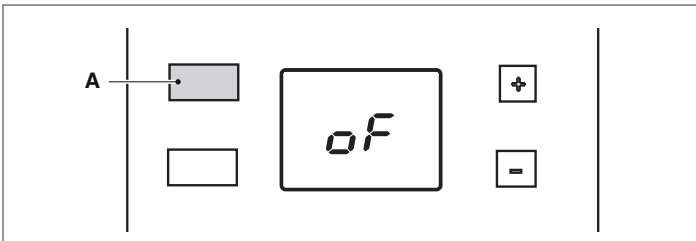

### 5.12 Shut down for long periods

If the appliance is not going to be used for a long period of time, the following operations should be carried out:

- press the ON-OFF/RESET (A) key
- switch the boiler OFF at the mains power switch
- shut-off the system's fuel and water taps.

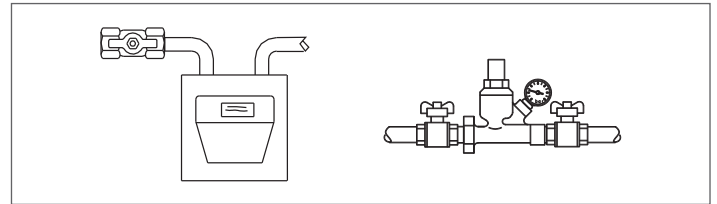

Empty the system if there is a risk of freezing.

### 5.13 How to care for the appliance

To clean the outer casing use only a clean damp cloth. Do not use any scourers or abrasive cleaners.

### 5.14 What if i suspect a gas leak

If you suspect a gas leak, turn off the gas supply at the gas meter, and contact your installer or local gas supplier. If you require further advice please contact your nearest Vokera office.

### 5.15 What if the appliance is due its annual service

#### Advice for tenants only

Your landlord should arrange for servicing. Advice for homeowners Please contact **Vokera Customer Services (0844 391 0999 (UK) or 056 7755057 (ROI))** if you would prefer a **Vokera** service engineer or agent to service your appliance. Alternatively your local Gas-Safe registered engineer may be able to service the appliance for you.

### 5.16 What if i need to call an engineer

If you think your appliance may have developed fault, please contact your installer or **Vokera Customer Services (0844 391 0999 (UK) or 056 7755057 (ROI))** have all your details to hand including full address and postcode, relevant contact numbers, and your completed appliance log book.

### 5.17 Parameters menu

Press the MENU (B) key for 2 seconds.

The two central segments of the digits blink and together with them some displayed icons.

Use the "+" or "-" key to select the wrench icon (). At this point the central segments switch off.

Press the MENU (B) key to enter the password (only for professionally qualified personnel) to access the technical menu.

Press the "+" key to increase the numeric value until you reach the value of the password.

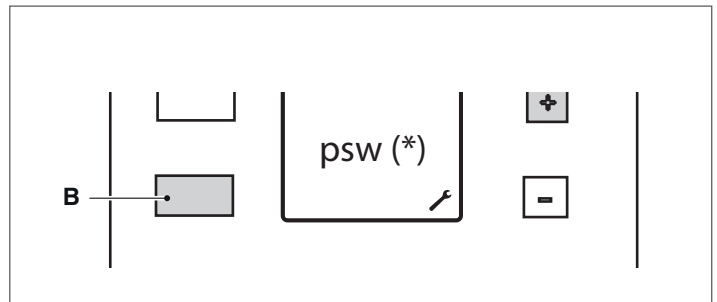

(\*) password value = **18**. Set the value of the password, available only for professionally qualified personnel. **The user can in no way access the TECHNICAL MENU.**

When accessing the technical menu the number "2" is displayed. Pressing the "+" or "-" key it is possible to select the successive parameter:  
**2** Burner output

- 4 Gas Type
  - 5 Flow Indicator Type
  - 6 Domestic hot water start wait time
  - 11 Domestic hot water circuit maximum setpoint
  - 20 Induced draught protection function
  - 40 Domestic hot water thermostat operation
  - 41 Displaying domestic hot water input temperature
  - 42 Displaying domestic hot water flow rate
  - rt Exiting the menu
  - rs Resetting factory settings
- Pressing the MENU (B) key confirms the values set.

To exit the TECHNICAL MENU press the "+" or "-" key until "rt" (return) is displayed. Pressing the MENU (B) key to return to the USER MENU. Pressing the ON-OFF/RESET (A) key you pass to the OFF state.

If no action is taken, once 2 minutes have passed the appliance exits the menu and returns to the normal operation screen.

### Table of parameters

Nr. PAR	PARAMETER DESCRIPTION	UNIT OF MEASUREMENT	MIN	MAX	VALUES	FACTORY SETTING
2	Selecting water heater output/capacity	l/min			11 13 17	11 13 17
4	Selecting methane/LPG				0 (METHANE) 1 (LPG)	0 (methane models) 1 (LPG models)
5	Selecting flow switch/flow indicator				0 (FLOW SWITCH) 1 (FLOW INDICATOR)	0
6	Domestic hot water start wait time	s	0,5	10	(steps of 0.5s)	0.5s
11	maximum setpoint of domestic hot water circuit	°C	36	65		65
20	Induced draught protection function		0	1	0 (NONE) 1 (ACTIVE)	1
40	Type of domestic hot water thermostat operation				0 (ABSOLUTE) 1 (CORRELATED)	0
41	Displaying domestic hot water input temperature	°C				
42	Displaying domestic hot water flow rate	NOT USED				
rt	Exiting the menu					
rs	Resetting factory settings					

### 5.18 Reset to factory settings

From the parameters menu, selecting "rs" allows you to reset the board parameters to the factory settings (Reset to factory settings). Pressing the MENU (B) key displays two underscores. Press the "-" key until the two underscores shift up. Press the "+" key to return to factory settings.

If you press the MENU (B) key instead of the "+" key the operation is annulled and you return to the previous menu.

To exit the TECHNICAL MENU press the "+" or "-" key until "rt" (return) is displayed, at this point pressing the MENU (B) key returns you to the USER MENU.

Pressing the ON-OFF/RESET (A) key you pass to the OFF state.

If no action is taken, once 2 minutes have passed the appliance exits the menu and returns to the normal operation screen.

 If you are replacing the electronic board it is necessary to set the parameters 2 (11-13-17) and 4 (methane - lpg) depending on the type of water heater used.

### 5.19 Reset to factory settings

From the parameters menu, selecting "rs" allows you to reset the board parameters to the factory settings (Reset to factory settings). Pressing the MENU (B) key displays two underscores. Press the "-" key until the two underscores shift up. Press the "+" key to return to factory settings.

If you press the MENU (B) key instead of the "+" key the operation is annulled and you return to the previous menu.

To exit the TECHNICAL MENU press the "+" or "-" key until "rt" (return) is displayed, at this point pressing the MENU (B) key returns you to the USER MENU.

Pressing the ON-OFF/RESET (A) key you pass to the OFF state.

If no action is taken, once 2 minutes have passed the appliance exits the menu and returns to the normal operation screen.

 If you are replacing the electronic board it is necessary to set the parameters 2 (11-13-17) and 4 (methane - lpg) depending on the type of water heater used.

## 6 COMMISSIONING

### 6.1 Gas supply installation

Inspect the entire installation including the gas meter, test for soundness and purge. Refer to BS 6891 for specific instruction.

### 6.2 Water pipe work

The water pipe work shall be flushed and tested in accordance with the Water Supply (water fittings) Regulations (Water Byelaws Scotland).

### 6.3 Pre-operation checks

Before attempting the initial lighting of the appliance, the following checks must be carried out:

- ensure all gas service valves from the meter to the appliance are open and the supply pipe has been properly purged;
- ensure the proper electrical checks have been carried out (see 8.6 ELECTRICAL CHECKS), particularly continuity, polarity and resistance to earth;
- ensure the 3 amp fuse – supplied with the appliance – has been fitted;
- ensure the appliance and associated pipe work has been filled and vented;
- ensure the flue system has been fitted properly and in accordance with the instructions;
- ensure all appliance service valves are open.

### 6.4 Initial lighting

Ensure the electrical supply to the appliance is switched on. Turn the selector knob to the 'on' position. Open a hot water outlet (preferably a bath tap) and ensure the flow rate exceeds 2 litres per minute.

The appliance will now go through an ignition sequence as described in 3.3 MODE OF OPERATION. Should the appliance fail to ignite, refer to 6.3 PRE-OPERATION CHECKS and/or section 8 CHECKS, ADJUSTMENTS, AND FAULT FINDING.

### 6.5 Checking the burner pressure

Although the burner pressure is factory set, it is necessary to check it during commissioning.

Isolate the appliance from the electrical supply and attach a suitable manometer to the gas valve outlet test nipple.

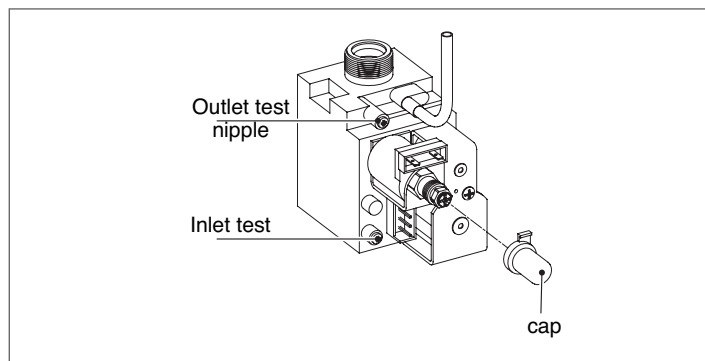

Light the appliance as described in 6.4 INITIAL LIGHTING and compare the reading on the manometer with the values described in 2.2 TECHNICAL DATA. If adjustment is required, follow the detailed instructions in section 8.3 CHECKING AND ADJUSTING BURNER PRESSURE. Once the burner pressure has been checked, isolate the appliance from the electrical supply, remove the manometer, and tighten the gas valve outlet test nipple.

### 6.6 Setting the outlet temperature

The hot water outlet temperature can be adjusted between 35°C - 60°C via the thermostat knob.

### 6.7 Final checks

- ⚠ Ensure all test nipples on the appliance gas valve are tight and checked for tightness.
- ⚠ Ensure the appliance flue system is fitted correctly and is properly secured.
- ⚠ Ensure all pipe work is re-checked for tightness.
- ⚠ Re-fit appliance casing.
- ⚠ Complete benchmark checklist. For uk only

Complete details of the appliance, controls, installation and commissioning in the Benchmark checklist at the back of this book. It is important that the Benchmark checklist is correctly completed and handed to the user. Failure to install and commission the appliance to the manufacturer's instructions will invalidate the warranty.

### 6.8 Instructing the user

Hand over all documentation supplied with this appliance – including these instructions – and explain the importance of keeping them in a safe place.

Explain to the user how to isolate the appliance from the gas, water and electricity supplies, and the locations of all drain points.

Show the user how to operate the appliance and its controls correctly. Explain to the user how to turn off the appliance for both long and short periods, and advise on the necessary precautions to prevent frost damage.

Explain to the user that for continued safe and efficient operation, the appliance must be serviced annually by a competent person.

## 7 SERVICING

### 7.1 General

Once the appliance has been serviced, the benchmark Service Record must be completed. For UK only: It is important that the Benchmark Service Record is correctly completed and handed to the user. Failure to install and commission the appliance to the manufacturers instructions will invalidate the warranty. To ensure the continued safe and efficient operation of the appliance, it is recommended that it is checked and serviced at regular intervals. The frequency of servicing will depend upon the particular installation conditions, but in general, once per year should be adequate.

It is the law that any servicing work is carried out by competent person such as a **Vokera** engineer, an approved service agent, British Gas, or other Gas-Safe registered personnel.

The following instructions apply to the appliance, but it should be remembered that the domestic hot water system will also require attention from time to time.

### 7.2 Routine annual servicing

- Check the operation of the appliance and ensure it functions as described in section 8 CHECKS, ADJUSTMENTS, AND FAULT FINDING.
- Compare the performance of the appliance with its design specification. The cause of any noticeable deterioration should be identified and rectified without delay.
- Thoroughly inspect the appliance for signs of damage or deterioration especially the flue system and the electrical apparatus.
- Check and adjust – if necessary – all burner pressure settings (see 8.3 CHECKING AND ADJUSTING BURNER PRESSURE).
- Carry out an analysis of the flue gases (see 8.5 EXTERNAL FAULTS), and visually check the condition of the entire flue assembly.
- Compare the results with the appliance design specification. Any deterioration in performance must be identified and rectified without delay.
- Ensure both flue venturis are clean and free from any debris or obstruction.
- Ensure both the burner and heat exchanger are clean and free from any debris or obstruction.
- Inspect all joints for signs of leakage and repair if necessary.
- Refer to the commissioning section and/or replacement of parts section for detailed instruction if required.

### 7.3 Replacement of components

Although it is anticipated that this appliance will give years of reliable, trouble free service, the life span of components will be determined by factors such as operating conditions and usage. Should the appliance develop a fault, the fault finding section will assist in determining which component is malfunctioning.

### 7.4 Component removal procedure

To remove a component, access to the interior of the appliance is essential. Isolate the appliance from the electrical supply and remove the fuse. And when necessary, close all service valves on the appliance, remove the appliance casing as described in section 4.8 CASING REMOVAL. Drain the water content from the appliance via an outlet or appropriate drain point. Ensure some water absorbent cloths are available to catch any residual water that may drip from the appliance or removed component.

Undertake a complete commissioning check as detailed in section 6 COMMISSIONING, after replacing any component.

 Always test for gas soundness if any gas carrying components have been removed or disturbed.

### 7.5 High limit thermostat

Carry out component removal procedure as described in 7.4 COMPONENT REMOVAL PROCEDURE. Locate and remove the ten screws that secure the air chamber cover.

Remove the air chamber cover.

Pull off electrical connections from the high limit thermostat, slacken and remove retaining screws.

Replace in the reverse order.

### 7.6 Flow switch

Carry out component removal procedure as described in 7.4 COMPONENT REMOVAL PROCEDURE.

Remove the appliance casing as described in 4.8 CASING REMOVAL. Disconnect the cold water inlet pipe from the bottom connection of the flow switch.

Disconnect the outlet pipe from the top connection of the flow switch. Detach the electrical plug/wires from the flow switch. Slacken and remove the lock-nut that secures the flow switch to the lower frame. Replace in the reverse order.

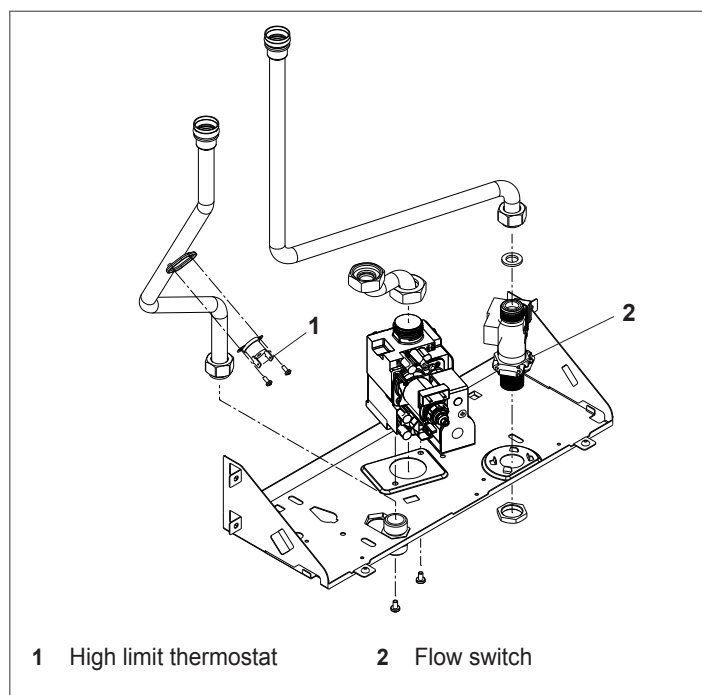

### PRINTED CIRCUIT BOARD (PCB)

Carry out component removal procedure as described in 7.4 COMPONENT REMOVAL PROCEDURE.

Remove the appliance casing as described in 4.8 CASING REMOVAL. Carefully slide out the control panel until the lugs on the lower right and left side of the panel are free from the slots on the appliance frame.

Remove the electrode lead from its clip on the PCB housing.

Locate and remove the two screws which secure the PCB cover & terminal cover, then remove cover, after carefully taking note of all wiring connections, disconnect all wiring from the PCB, locate and remove the PCB securing screws, remove PCB.

Replace in the reverse order.

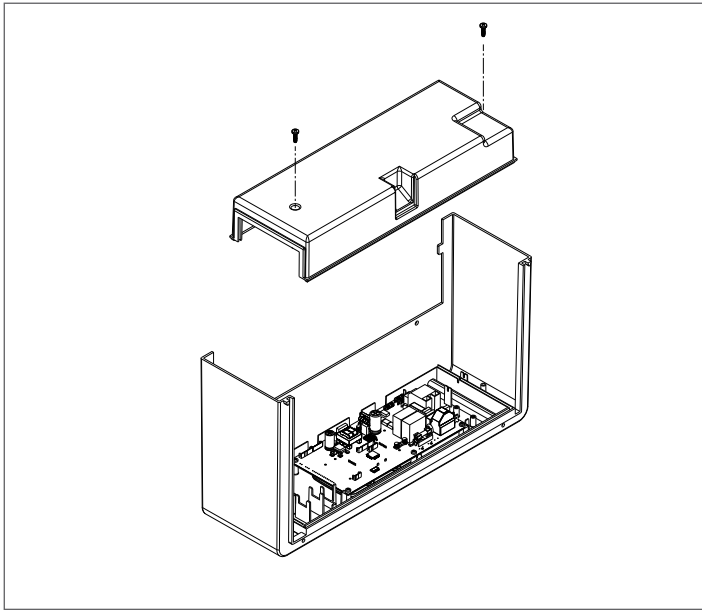

**!** Ensure that the replacement PCB has the correct “Jumper Tag” configuration (see section 2.4 EXTERNAL WIRING).

## 7.7 Burner

Carry out component removal procedure as described in 7.4 COMPONENT REMOVAL PROCEDURE.

- disconnect the glowplug cable connection
- remove the lower cable grommet from its seat on the air distribution box
- disconnect the burner thermostat (I) removing the relative fastening clip
- fully unscrew the top nut of the gas valve train
- loosen the nuts (A) of the by-pass train
- loosen the nut (B) of the burner/flow meter train
- take out the clips (C) securing the trains to the burner
- disconnect the trains (D) from the burner
- unscrew the 4 screws (E) fixing the burner to the back board
- take out the burner (F), unscrew the screws (G) fixing the collector to the burner

Replace in the reverse order.

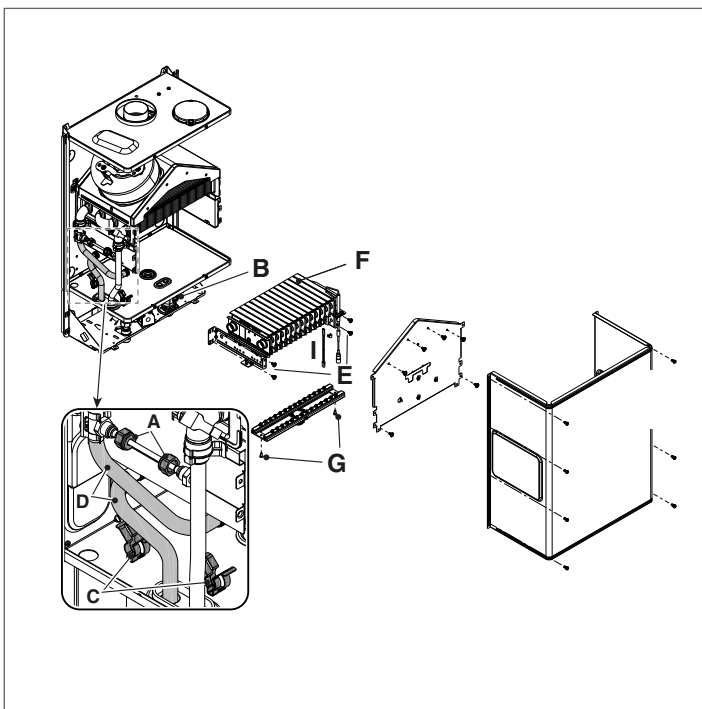

## 7.8 Flue fan

Carry out component removal procedure as described in 7.4 COMPONENT REMOVAL PROCEDURE.

Remove the appliance casing as described in 4.8 COMPONENT REMOVAL PROCEDURE. Locate and remove the screws that secure the air chamber cover. Remove the air chamber cover.

Locate and remove the screws that secure the flue assembly. Disconnect the electrical connections and silicone tubes attached to the fan, noting their positions. Disconnect the maintenance clip that secures the flue outlet pipe to the fan, ease the fan & flue hood assembly from its location. Locate and remove the screws that secure the fan to the flue hood. Remove the fan to flue elbow. Replace in the reverse order. Ensure all seals are in good condition, taking care to ensure they are replaced correctly.

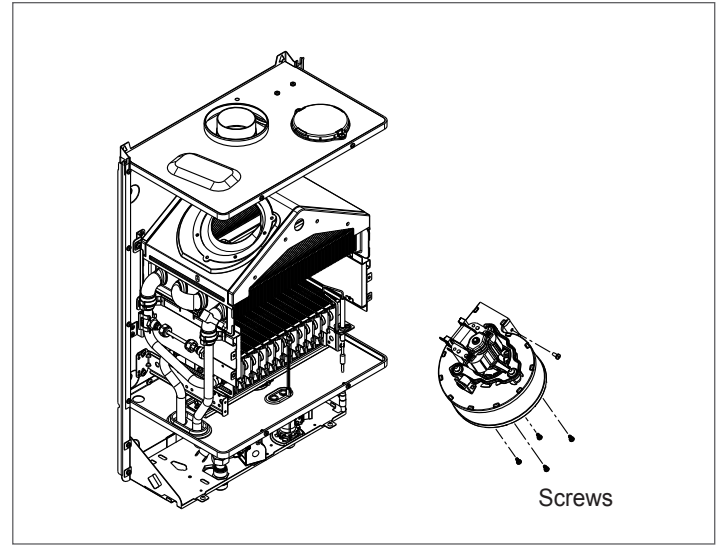

## 7.9 Heat exchanger

Carry out component removal procedure as described in 7.4 COMPONENT REMOVAL PROCEDURE.

Unscrew and remove the air chamber front cover.

Locate and remove the six screws around the inner combustion cover and remove. Remove locking pins and disconnect the pipes, from the flow and return connections on the heat exchanger.

Disconnect the electrical plugs from the primary thermistor, the heat exchanger can now be withdrawn from the appliance. Replace in the reverse order. Ensure all seals are in good condition, taking care to ensure they are replaced correctly.

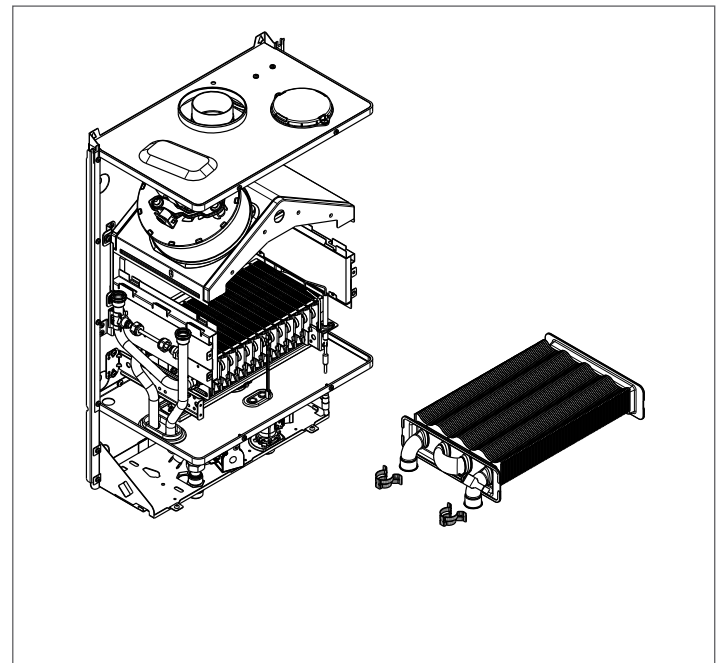



## 8 CHECKS, ADJUSTMENTS, AND FAULT FINDING

### 8.1 Checking appliance operation

When carrying out any repairs or servicing to the appliance, the relevant commissioning procedure must be undertaken to ensure the continued safe operation of the appliance. Particular attention should be made to ensure gas soundness, water soundness, and the electrical integrity of the appliance.

### 8.2 Appliance mode of operation

When there is a request for hot water via a hot water outlet or tap, the water flow switch senses water movement thereby energising the fan.

⚠ There must be sufficient inlet water pressure and flow (min. 0,15 bar/ 2 lpm) to ensure the water flow switch is activated. If there is insufficient pressure and/or flow, the appliance will be prevented from operating. When the fan runs, it proves the differential air pressure switch which in-turn allows an ignition sequence to begin.

⚠ The ignition sequence lasts approximately 7 seconds, during which the appliance will continue to spark even if the burner has already lit. If the spark/sensing electrode does not sense ignition the appliance will then go to lockout. Ignition is sensed by the electronic circuitry to ensure flame stability at the burner. Once successful ignition has been achieved, the electronic circuitry allows the full gas rate through the appliance. When the appliance reaches the desired temperature the burner will modulate to maintain the set temperature. Should the temperature continue to rise the burner will shut off when the maximum operating temperature is attained. When the request for heat and/or hot water has been satisfied, the fan may continue to operate to dissipate any residual heat within the appliance.

### 8.3 Checking and adjusting burner pressure

Although the burner pressure is factory set, it is necessary to check it during servicing or if the gas valve has been removed. Isolate the appliance from the electrical supply and attach a suitable manometer to the gas valve outlet test nipple.

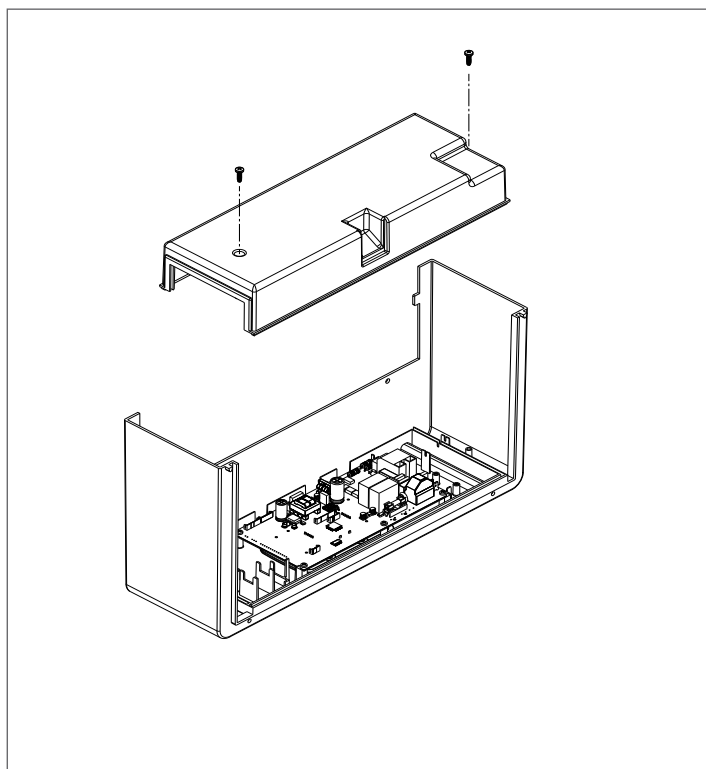

#### SETTING THE MAXIMUM BURNER PRESSURE

Light the appliance as described in 5.10 & 6.4 and compare the reading on the manometer with the value described in 2.2 TECHNICAL DATA. If adjustment is required, remove the protective cap from the gas valve modulating coil assembly and turn the outer (10mm) nut clockwise to increase, or counterclockwise to decrease the burner pressure.

⚠ You should ensure that one or two hot water outlets are fully open during the above procedure. This will ensure that the output of the appliance (burner pressure) is not compromised due to a high outlet temperature.

#### SETTING THE MINIMUM BURNER PRESSURE

Once the maximum burner pressure has been checked and/or adjusted, remove one of the grey wires from the modulating coil. Compare the reading on the manometer with the value described in 2.2 TECHNICAL DATA. If adjustment is required, turn the inner (red) cross-head screw clockwise to increase, or counter-clockwise to decrease the burner pressure, whilst ensuring that the outer (10mm) nut does not move. When checking and/or adjustment has been completed, isolate the appliance from the electrical supply, replace the protective cap, refit the grey wire to the modulating coil, remove the manometer, and tighten the outlet test nipple.

⚠ A gas soundness check must be carried out.

### 8.4 Maintenance

To ensure correct operation over time, the appliance should be checked by a qualified professional at least once a year.

**IMPORTANT:** before performing any cleaning or maintenance work, or before opening or removing the boiler panels, turn the appliance off by shutting off the gas tap.

**Check** that the flue gases passage sections of the heat exchanger are not obstructed. Use a wet soapy cloth to clean the external panels.

**Do not** use abrasive solvents, powders or sponges.

**Do not** clean the appliance or its component parts with highly flammable substances such as : petrol, alcohol or heavy oil.

**Check** electrode position and distance.

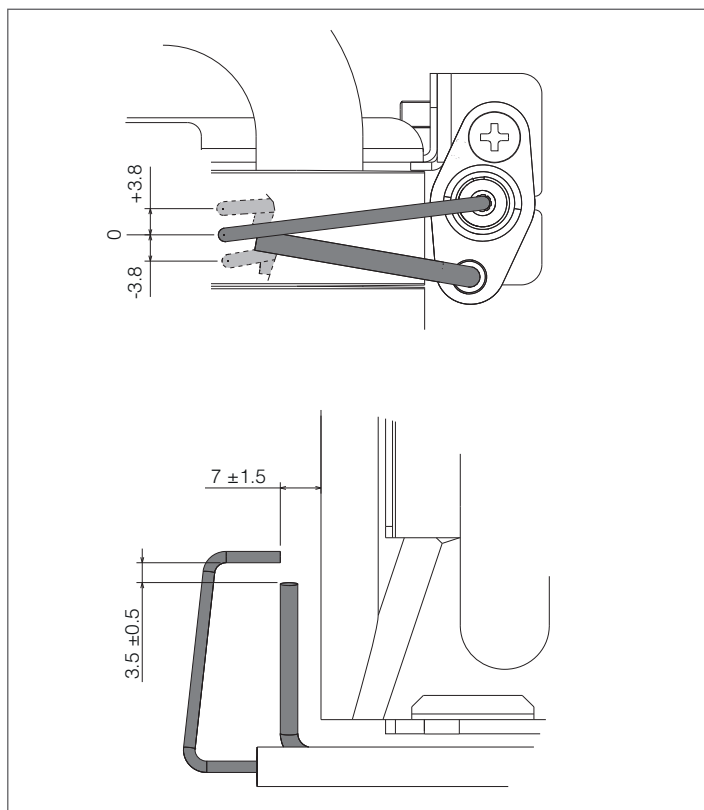

## 8.5 External faults

Before carrying out any fault-finding or component replacement, ensure the fault is not attributable to any aspect of the installation.

### INSTALLATION FAULTS

Symptom	Possible causes
No ignition	Check external wiring. Check cold supply is connected to cold inlet.
Poor hot water	Check gas supply. Check adjust flow rate.
Unstable flame picture	Check flue system.

## 8.6 Electrical checks

Any electrical checks must be carried out by a suitably qualified person.

### EARTH CONTINUITY TEST

Isolate the appliance from the electrical supply, and using a suitable multi-meter carry out a resistance test. Connect test leads between an appliance earth point and the earth wire of the appliance supply cable. The resistance should be less than 1 ohm. If the resistance is greater than 1 ohm check all earth wires and connectors for continuity and integrity.

### SHORT CIRCUIT CHECK

Isolate the appliance from the electrical supply, and using a suitable multi-meter, carry out a short circuit test between the Live & Neutral connections at the appliance.

Repeat above test on the Live & Earth connections at the appliance term.



Should it be found that the fuse has failed but no fault is indicated, a detailed continuity. Check will be required to trace the fault. A visual inspection of components may also assist in locating the fault.

### POLARITY CHECK

With the appliance connected to the electrical supply and using a suitable multi-meter, carry out the following voltage tests:

- connect test leads between the Live & Neutral connections at the appliance. The meter should read approximately 230V ac. If so proceed to next stage. If not, see REVERSED POLARITY OR SUPPLY FAULT
- connect test leads between the Live & Earth connections at the appliance. The meter should read approximately 230V ac. If so proceed to next stage. If not, see REVERSED POLARITY OR SUPPLY FAULT
- Connect test leads between the Neutral & Earth connections at the appliance. The meter should read approximately 0 – 15Vac. If so polarity is correct. If not, see REVERSED POLARITY OR SUPPLY FAULT

### REVERSED POLARITY OR SUPPLY FAULT

Repeat the above tests at the appliance isolator, if testing reveals correct polarity and/or supply at the isolator, re-check wiring and connections between the isolator and the appliance. If tests on the isolator also reveal reversed polarity or a supply fault, consult the local electricity supplier for advice.

### RESISTANCE TO EARTH CHECK

Isolate the appliance from the electrical supply, and using a suitable multi-meter carry out a resistance test. Connect test leads between the Live & Earth connections at the appliance. If the meter reads other than infinity there is a fault that must be isolated, carry out a detailed continuity check to identify the location of the fault.



These series of checks must be carried out before attempting any fault-finding procedures on the appliance. On completion of any task that required the disconnection and re-connection of any electrical wiring or component, these checks must be repeated.

## 8.7 Operating faults and reset

In the event of a fault, the displays summarised and described in the table are shown.

Error type	Transitory Definitive	Error code	Icons
Limit thermostat alarm	Definitive	02	
Air pressure switch fault	Transitory	03	
Burner thermostat alarm	Definitive	04	
Air pressure switch alarm	Definitive	03	
ACF alarm lockout module	Definitive	01	
ACF electronics fault alarm	Definitive	01	
parasite flame fault	Transitory	11	
Overtemperature fault	Definitive	88°C flashing	
Domestic hot water NTC Fault	Transitory	06	
Input NTC Fault	Transitory	08	

In the event of a transitory fault the appliance independently attempts a reset of operations.

In the event of a permanent fault it is necessary to reset the normal operation of the appliance by pressing the ON - OFF/RESET (A) key. This operation can be repeated a maximum of 2 times. If the problem is not resolved, request help from the Technical Assistance Centre.

The system provides for the alarms to remain operational even in the ON-OFF/RESET state. In this state they are not displayed however. In the event a lockout occurs when the function is OFF, to reset it the water heater must be set to ON and then to OFF again.

## 8.8 Fault finding

Before attempting any fault-finding, the electrical checks as detailed in 8.6 ELECTRICAL CHECKS must be carried out.

Isolate the appliance from the electrical supply and remove the casing and PCB cover.

Restore the electrical supply to the appliance, turn the selector switch to the "on" position, and open a hot water outlet. The appliance should now function as described in section 8.2 APPLIANCE MODE OF OPERATION. Should the appliance fail to respond, the internal fuse and connectors should be checked to ensure integrity and continuity. If the appliance still fails to respond, refer to the detailed fault-finding flow-charts overleaf.



## 9 L.P.G. INSTRUCTIONS

TECHNICAL DATA		G31	
Inlet pressure (LPG)		37	mbar
Maximum burner pressure		36,00	mbar
Minimum burner pressure		4,80	mbar
Gas rate		2,33	Sm <sup>3</sup> /h
Injector size		13 x 0,78	mm

RELATED DOCUMENTS		
BS 5440	PART 2	Flues
BS 5440	PART 1	Flues & ventilation
BS 5546	PART 1	Installation of gas hot water supplies for domestic purposes
BS 6891		Low pressure installation pipes
BS 5482		Domestic butane & propane gas burners in permanent dwellings

### 9.1 Gas supply

The gas supply must be connected to the appliance by a competent LPG installer and must be of sufficient size to supply the appliance at its maximum output.

An existing supply must be checked to ensure that it is of adequate size to deal with the maximum rated input of this and any other appliances that it serves.

### 9.2 Gas supply installation

The entire installation, including the meter, must be purged and checked for gas soundness.

### 9.3 Checking and adjusting burner pressure

Although the burner pressure is factory set, it is necessary to check it during servicing or if the gas valve has been removed. Isolate the appliance from the electrical supply and attach a suitable manometer to the gas valve outlet test nipple.

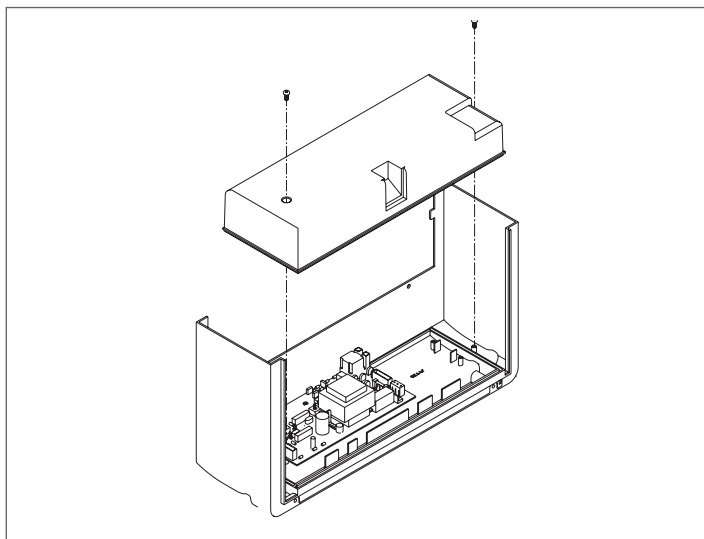

### SETTING THE MAXIMUM BURNER PRESSURE

Light the appliance as described in 5.10 & 6.4 and compare the reading on the manometer with the value described in 2.2 TECHNICAL DATA. If adjustment is required, remove the protective cap from the gas valve modulating coil assembly and turn the outer (10mm) nut clockwise to increase, or counterclockwise to decrease the burner pressure.

**!** You should ensure that one or two outlets are open during the above procedure. This will ensure that the output of the appliance (burner pressure) is not compromised due to a high outlet temperature.

### SETTING THE MINIMUM BURNER PRESSURE

Once the maximum burner pressure has been checked and/or adjusted, remove one of the grey wires from the modulating coil. Compare the reading on the manometer with the value described in 2.2 TECHNICAL DATA. If adjustment is required, turn the inner (red) cross-head screw clockwise to increase, or counter-clockwise to decrease the burner pressure, whilst ensuring that the outer (10mm) nut does not move. When checking and/or adjustment has been completed, isolate the appliance from the electrical supply, replace the protective cap, refit the grey wire to the modulating coil, remove the manometer, and tighten the outlet test nipple.

**!** Important, a gas soundness check must be carried out.

## 10 GAS TRANSFORMATION

Converting gas from one form to another can be done easily, even with the appliance already installed.

**!** The conversion shall only be carried out by qualified personnel.

The water heater is supplied to operate with methane gas (G20) or LPG (G31) in accordance with the indications of the product label.

The appliance can be converted from one type of gas to another using one of the specific kits provided upon request:

- Methane conversion kit
- LPG conversion kit

Proceed as follows to perform the conversion:

- switch off the electrical supply
- remove in succession the casing, the air distribution box cover and the combustion chamber cover
- disconnect the glowplug cable connection
- remove the lower cable grommet from its seat on the air distribution box
- disconnect the burner thermostat (I) removing the relative fastening clip
- fully unscrew the top nut of the gas valve train
- loosen the nuts (A) of the by-pass train
- loosen the nut (B) of the burner/flow meter train
- take out the clips (C) securing the trains to the burner
- disconnect the trains (D) from the burner
- unscrew the 4 screws (E) fixing the burner to the back board
- take out the burner (F), unscrew the screws (G) fixing the collector to the burner
- from the conversion kit take the complete LPG collector and relative LPG burner flange.
- fix the burner, the collector and the flange using the screws previously removed.

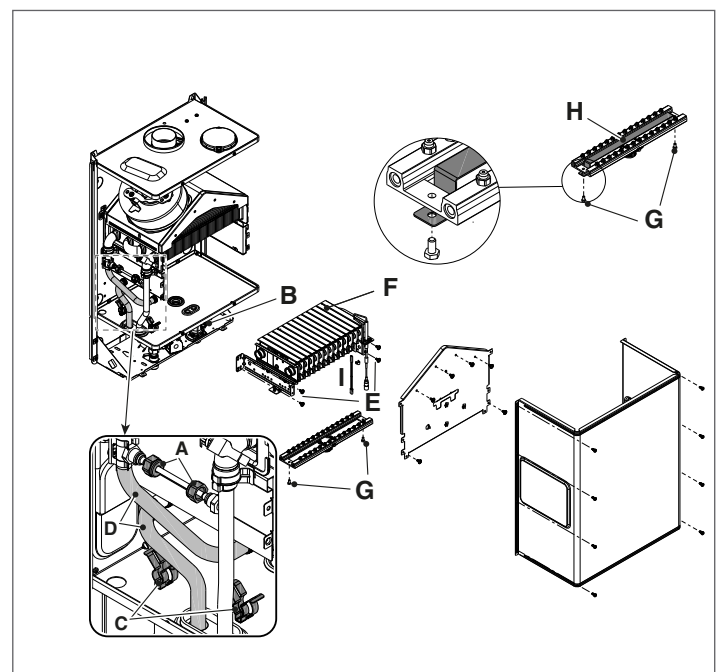

For the conversion from methane gas to LPG, install the burner flange (H).

For the conversion from LPG to methane gas, remove it.

**!** Before removing the burner flange, empty the water heater as described in the paragraph "Emptying the water heater".

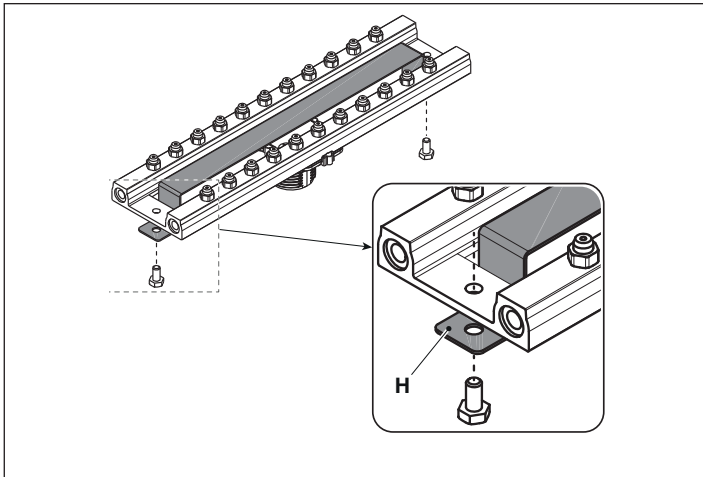

Then set **Parameter 4** (see paragraph "Parameters menu") as follows:

Conversion from METHANE to LPG	
Parameter	Value
4	1
Conversion from LPG to METHANE	
Parameter	Value
4	0

## 10.1 Adjustments

The appliance has already been factory set by the manufacturer. However, should it need to be readjusted, for example after non-scheduled maintenance, replacing the gas valve or gas conversion, proceed as described below.

**!** Adjustments to maximum power must be performed in the indicated sequence and only by qualified technicians.

- Remove the casing by unscrewing the fixing screws A (see section "4.8 CASING REMOVAL").
- Loosen the screw of the pressure test point (1) downstream from the gas valve by roughly two turns, then connect the pressure gauge
- Disconnect the compensation connector (5) from the gas valve
- Remove the protective hood (2)
- Open a water tap to its maximum flow rate, set the temperature selector to maximum and power up the water heater

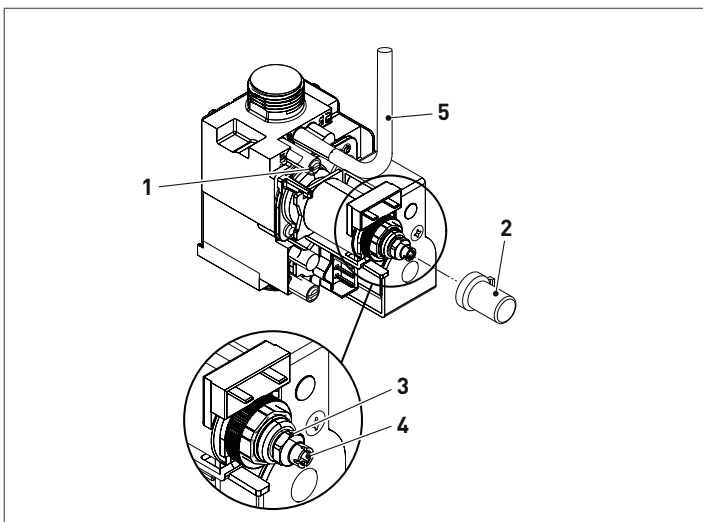

### Adjusting to the maximum value:

- Screw the nut (3) fully on until obtaining the gas pressure shown in the table

Maximum gas pressure at nozzles		
G20	15,20	mbar
	155,00	mm. W.C.
LPG	35,30	mbar
	359,96	mm. W.C.

### Adjusting to the minimum value:

- disconnect one of the two electric cables from the coil
- screw or unscrew the hex head socket screw (4) to adjust the minimum until obtaining the gas pressure value shown in the table
- put back the protective cap (2)

Minimum gas pressure at nozzles		
G20	2,10	mbar
	21,41	mm. W.C.
LPG	5,00	mbar
	50,99	mm. W.C.

- Reconnect the compensation socket to the gas valve (5)
- Disconnect the pressure gauge and re-tighten the pressure test point screw (1)

**!** Please remember that for operation with LPG, the appliance needs a gas supply pressure adjuster, which should be set to 37 mbar.

**!** Please remember that for operation with LPG, a gas pressure regulator at the appliance power supply is required, set to 37 mbar for propane.

## GAS FIRED CONTINUOUS FLOW WATER HEATER COMMISSIONING CHECKLIST

**This Commissioning Checklist is to be completed in full by the competent person who commissioned the water heater as a means of demonstrating compliance with the appropriate Building Regulations and then handed to the customer to keep for future reference**

Failure to install and commission according to the manufacturer's instructions and complete this Benchmark Commissioning Checklist will invalidate the warranty. This does not affect the customer's statutory rights.

Customer name:	Telephone number:
Address:	
Water Heater Make & Model:	
Serial Number:	
Commissioned by (PRINT NAME):	Gas Safe Register Number:
Company name:	Telephone number:
Company address:	
Commissioning date:	
<b>To be completed by the customer on receipt of a Building Regulations Compliance Certificate*:</b>	
Building Regulations Notification Number (if applicable)	

CONTROLS			
Is there a separate temperature control fitted	Yes		No
Have they been explained to the customer	Yes		No
Has the Appliance been set to the required MAX temp.	Yes		No
If NO has the Appliance been set to the required temp.	Yes		No

SYSTEM			
Is there a filter on the incoming mains	Yes		No
Is the system on a secondary return	Yes		No
Has an unvented kit been installed	Yes		No
If yes please record Safety Valve Size and rating	Size	Rating	
Does the discharge pipe comply with current building regulations			Yes
Please record location of Pressure Reducing Valve			
Pressure Reducing Valve Setting			
Expansion Vessel Size			
Expansion Vessel Charge Pressure			
Has the system been installed with a storage vessel	Yes		No

DOMESTIC HOT WATER MODE			
Gas Rate at High Fire	m <sup>3</sup> /hr	ft <sup>3</sup> /hr	
Burner Pressure	Lo	mbar	Hi
Inlet Pressure Dynamic at Hi Fire and all other appliances running	mbar		
Inlet water temp			°C
Water Heater Set Temperature			°C
Maximum Flow Rate Achieved	L/min		
Is the installation in a hard water area (above 150mg/L)	Yes		No
If Yes What Type of Scale Reducer has been Fitted			
Hot Water checked at all outlets	Yes	Temp	°C

FLUEING			
What type of water heater is fitted	Internal	External	
EXTERNAL is the unit mounted fully outside	Yes		No
If NO explain in detail where the appliance is mounted			
INTERNAL does the flueing comply with current standards	Yes		No
If the flueing to manufacturers instructions	Yes		No

CONDENSING WATER HEATERS ONLY			
Has the condensate drain has been installed as per manufacturers instructions and/or BS5446/BS6798	Yes		No

FULL INSTALLATION			
Record the following:	At max rate: CO ppm	and	CO/CO2 Ratio
	At min. Rate: (where possible) CO ppm	and	CO/CO2 Ratio
Does the hot water system fully comply with the appropriate Building Regulations			Yes
The water heater and associated products have been installed and commissioned in accordance with all manufacturers instructions			Yes
The full operation of the water heater and any controls have been demonstrated to and understood by the customer			Yes
The manufacturers literature including Benchmark Checklist and Service Record, has been explained and left with the customer			Yes

Commissioning Engineer's Signature
Customer's Signature
(To confirm satisfactory demonstration and receipt of manufacturer's literature)

\*All installations in England and Wales must be notified to Local Authority Building Control (LABC) either directly or through a Competent Persons Scheme. A Building Regulations Compliance Certificate will then be issued to the customer.



## SERVICE RECORD

It is recommended that your heating system is serviced regularly and that the appropriate Service Interval Record is completed.

### Service Provider

Before completing the appropriate Service Interval Record below, please ensure you have carried out the service as described in the manufacturer's instructions. Always use the manufacturer's specified spare part when replacing controls.

<b>SERVICE 01</b>	Date:	<b>SERVICE 02</b>	Date:
Engineer name:		Engineer name:	
Company name:		Company name:	
Telephone No:		Telephone No:	
Operative ID No:		Operative ID No:	
Comments:		Comments:	
Signature		Signature	
<b>SERVICE 03</b>	Date:	<b>SERVICE 04</b>	Date:
Engineer name:		Engineer name:	
Company name:		Company name:	
Telephone No:		Telephone No:	
Operative ID No:		Operative ID No:	
Comments:		Comments:	
Signature		Signature	
<b>SERVICE 05</b>	Date:	<b>SERVICE 06</b>	Date:
Engineer name:		Engineer name:	
Company name:		Company name:	
Telephone No:		Telephone No:	
Operative ID No:		Operative ID No:	
Comments:		Comments:	
Signature		Signature	
<b>SERVICE 07</b>	Date:	<b>SERVICE 08</b>	Date:
Engineer name:		Engineer name:	
Company name:		Company name:	
Telephone No:		Telephone No:	
Operative ID No:		Operative ID No:	
Comments:		Comments:	
Signature		Signature	
<b>SERVICE 09</b>	Date:	<b>SERVICE 10</b>	Date:
Engineer name:		Engineer name:	
Company name:		Company name:	
Telephone No:		Telephone No:	
Operative ID No:		Operative ID No:	
Comments:		Comments:	
Signature		Signature	





Cod. 20146341 - 11/18 - Ed. 1

**Registered address:**

Vokèra Ltd  
Borderlake House  
Unit 7 Riverside Industrial Estate  
London Colney  
Herts AL2 1HG

[enquiries@vokera.co.uk](mailto:enquiries@vokera.co.uk)

[www.vokera.co.uk](http://www.vokera.co.uk)  
[www.vokera.ie](http://www.vokera.ie)

**Sales, General Enquires**

T 0844 391 0999  
F 0844 391 0998

Vokèra Ireland  
West Court, Callan  
Co Kilkenny  
T 056 7755057  
F 056 7755060

Vokèra Limited reserve the right to change  
specification without prior notice.  
Consumers statutory rights are not affected.

Company Reg No: 1047779